

9

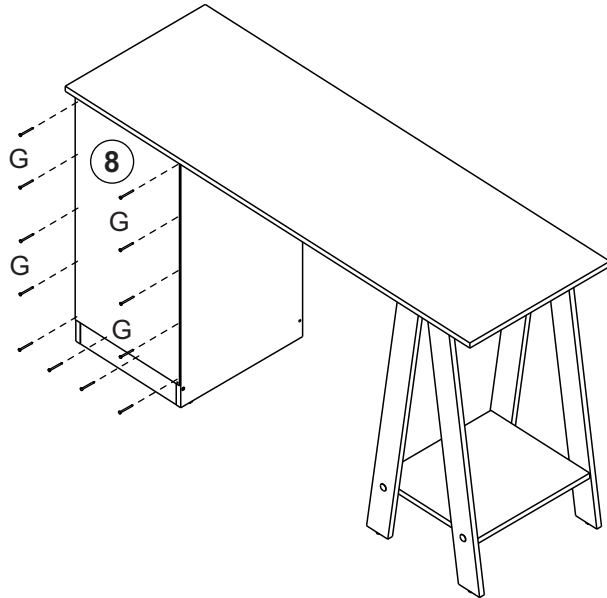

G (38x)



10

**PESO MÁXIMO SUPORTADO**  
**MAXIMUM WEIGHT SUPPORTED**  
**PESO MAXIMO SOPORTADO**

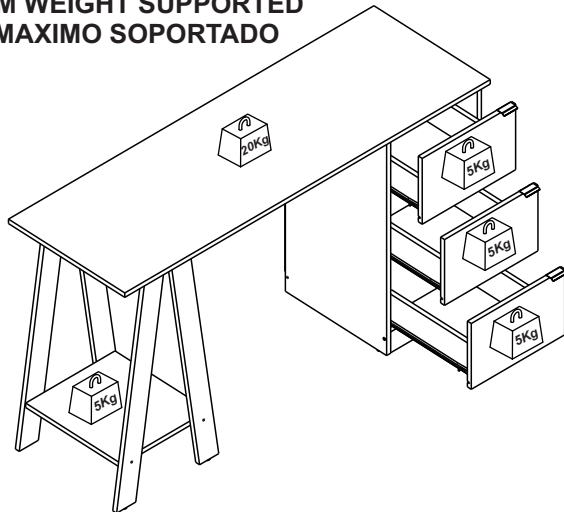

**Manutenção e Limpeza:**

Use pano levemente umedecido com água, seguido de pano seco. Nunca utilize produtos químicos ou abrasivos.

**Maintenance and Cleaning:**

Use a cloth slightly dampened with water, followed by a dry cloth. Never use chemicals or abrasives.

**Mantenimiento y limpieza:**

Use un paño ligeramente humedecido con agua, seguido de un paño seco. Nunca use productos químicos o abrasivos.

# NOVA MÓBILE.



**REF. B62**

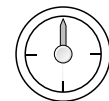

60 min.

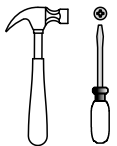

Nova Móble Ind. e Comércio Ltda.

Estrada Pedro Salgado, nº 1620 - Fone: +55 (054) 2105-8400 - +55 (054) 99614-6360

CEP: 95706-500 - Bento Gonçalves - RS - Site: [www.novamobile.com.br](http://www.novamobile.com.br) - E-mail: [novamobile@novamobile.com.br](mailto:novamobile@novamobile.com.br)

Rev. 00 - 30/11/2023

# FERRAGENS / HARDWARE LIST / LISTA DE HERRAJES



## ATENÇÃO!!!

Em caso de uso de parafusadeira comece com um torque bem leve e vá aumentando até achar o ideal. Aperte somente até travar. Torque excessivo pode espanar o parafuso e danificar a peça comprometendo sua correta fixação.

## ATTENTION!!!

If using a screwdriver, start with a very light torque and increase until you find the ideal. Press only until it locks. Excessive torque can strip the bolt and damage the part, compromising its correct fixation.

## ATENCIÓN!!!

En caso de utilizar un destornillador, comience con un torque muy ligero y vaya aumentando hasta encontrar el ideal. Presione solo hasta que se detener. Torsión excesivo puede desempolvar el tornillo y dañar la pieza, comprometiendo su correcta fijación.

LOC.	IMAGEM / IMAGE / IMAGEN	QUANTIDADE # OF PIECES CANTIDAD
A	4,5x45mm	18
B	4,0x25mm	04
C		14
D		04
E		32
F		08
G		45
H		06
I		03
J		02
K		02
L	3,5x14mm	18
M	3,5x12mm	24
N		08
O		03

**6 3x**

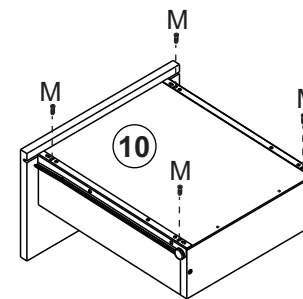
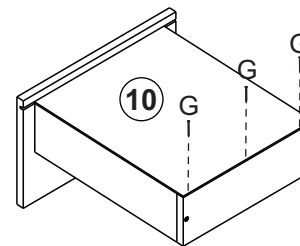
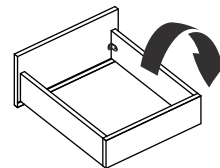

**G (9x)**



**I (3x)**

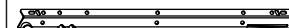

**M (12x)**



**7 3x**

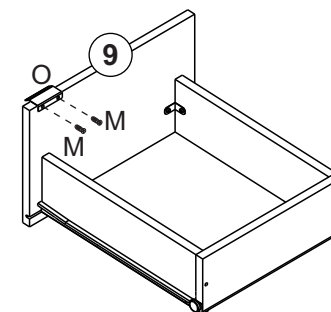

**M (6x)**

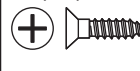

**8**

**B (8x)**

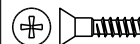

**J (2x)**

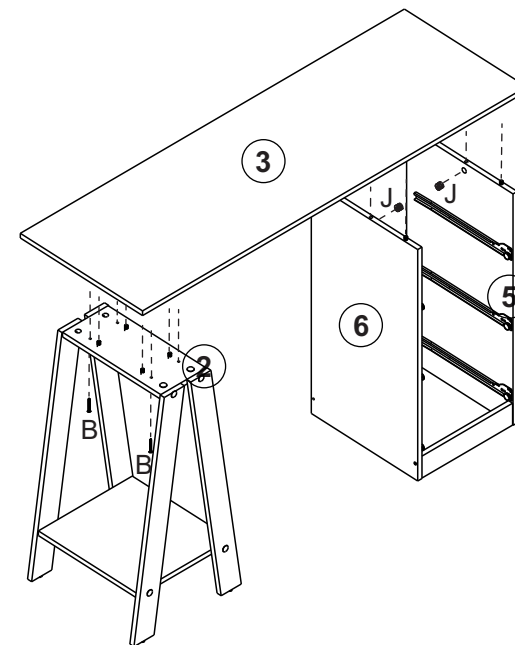

4

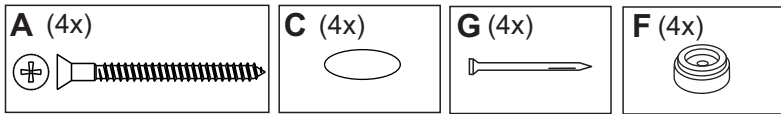
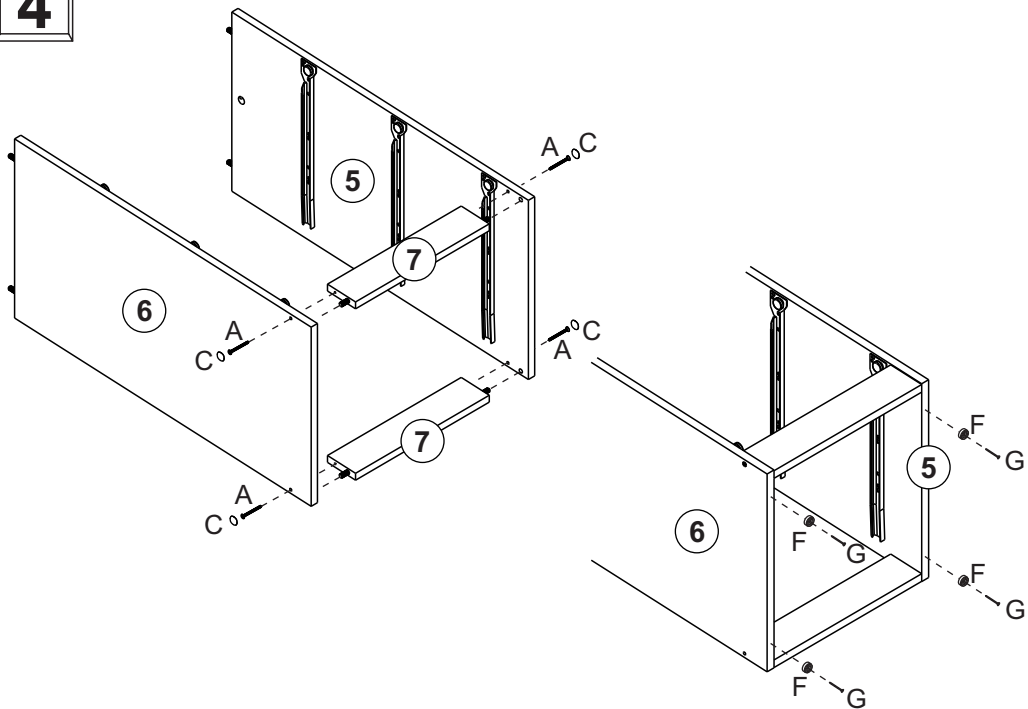

5 3x

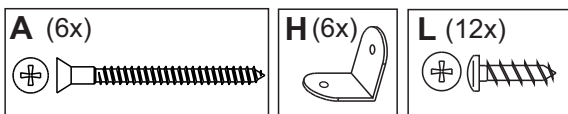
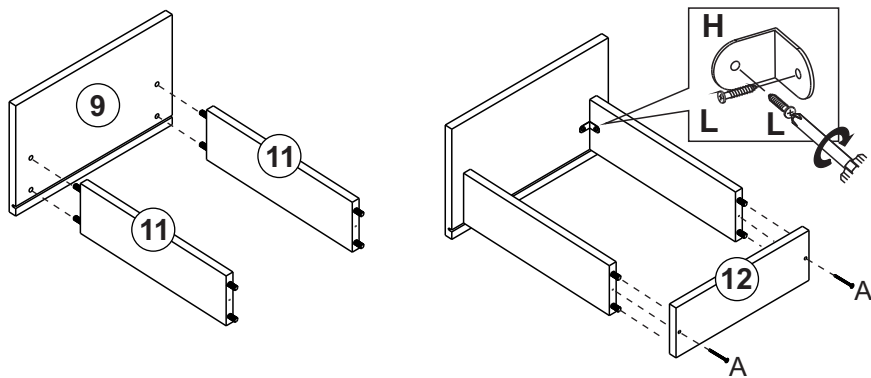

PARTES DO PRODUTO / PRODUCT PARTS / PARTES DEL PRODUCTO

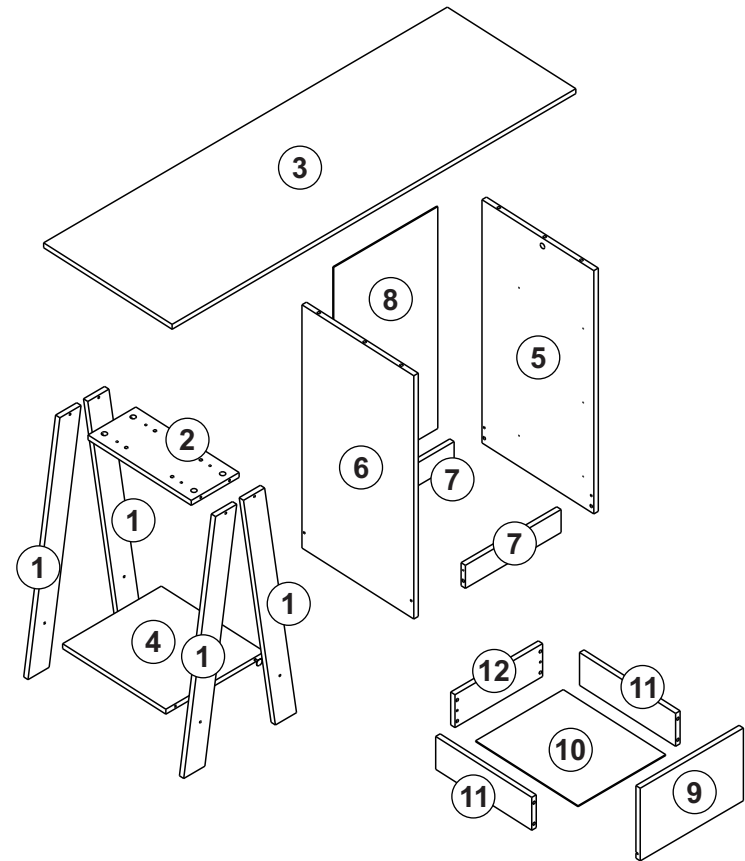

Loc.	Descrição / Description / Denominación	mm	Quantidade # Of Pieces Cantidad
1	Pé/Foot/Pata	758x70x15	04
2	Base superior/Upper base/Base superior	360x160x15	01
3	Tampo/Top/Tapa	1350x448x15	01
4	Base inferior/Lower base/Base inferior	360x448x15	01
5	Lateral direita/Right side/Lateral derecha	740x390x15	01
6	Lateral esquerda/Left side/Lateral izquierda	740x390x15	01
7	Rodapé/Baseboard/Zócalo	70x320x15	02
8	Costa/Back/Revés	675x348x15	01
9	Frente de gaveta/Drawer front/Frente cajón	221x346x15	03
10	Fundo de gaveta/Drawer bottom/Fondo cajón	356x292x15	03
11	Lateral de gaveta/Drawer side/Lateral cajón	335x100x15	03
12	Traseiro de gaveta/Drawer back/Trasero cajón	292x100x15	03

1

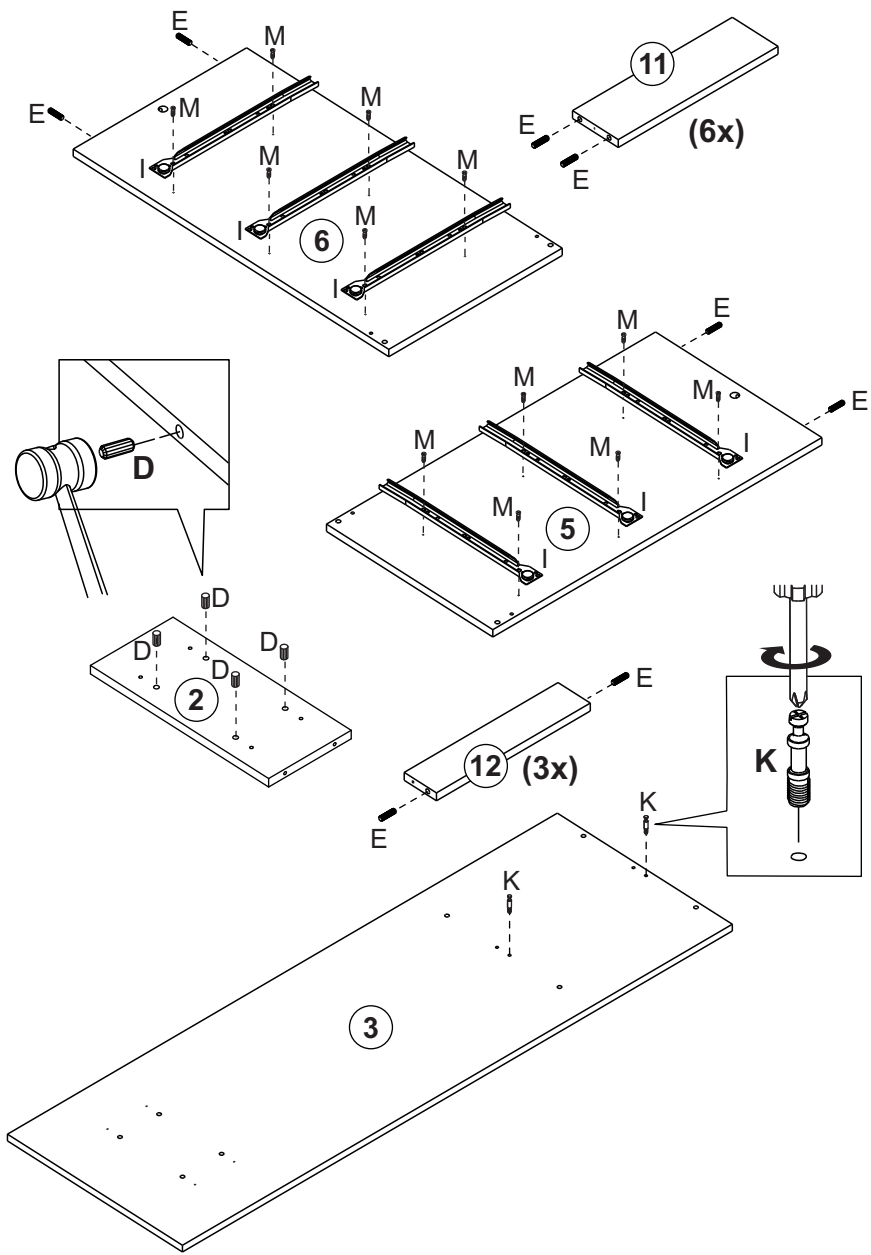

- D (4x)**
- E (32x)**
- K (2x)**

2

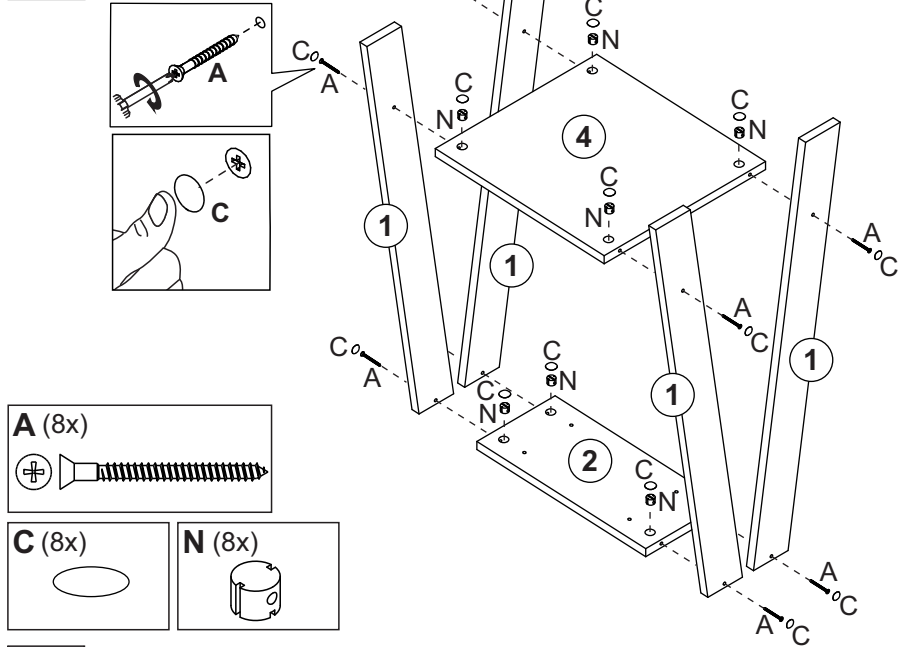

- A (8x)**
- C (8x)**
- N (8x)**

3

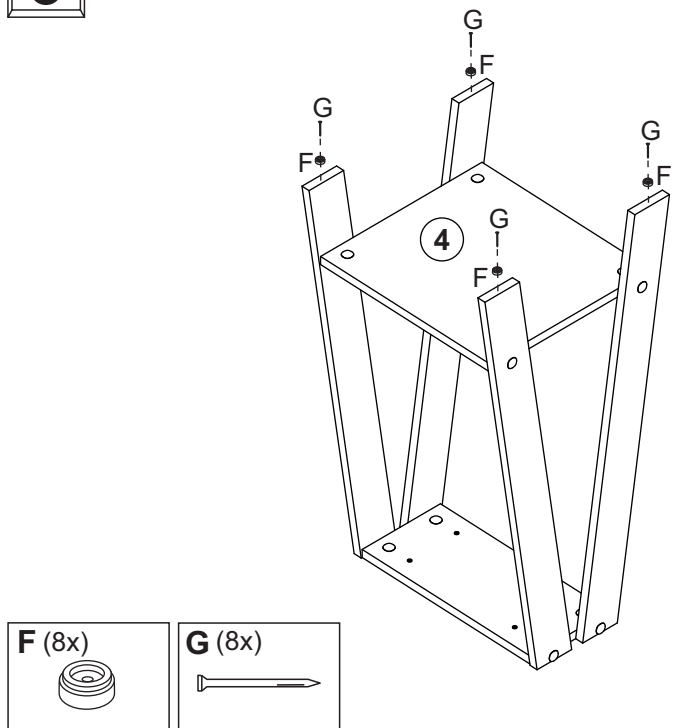

- F (8x)**
- G (8x)**