

185 - GR DOBLE CASAL

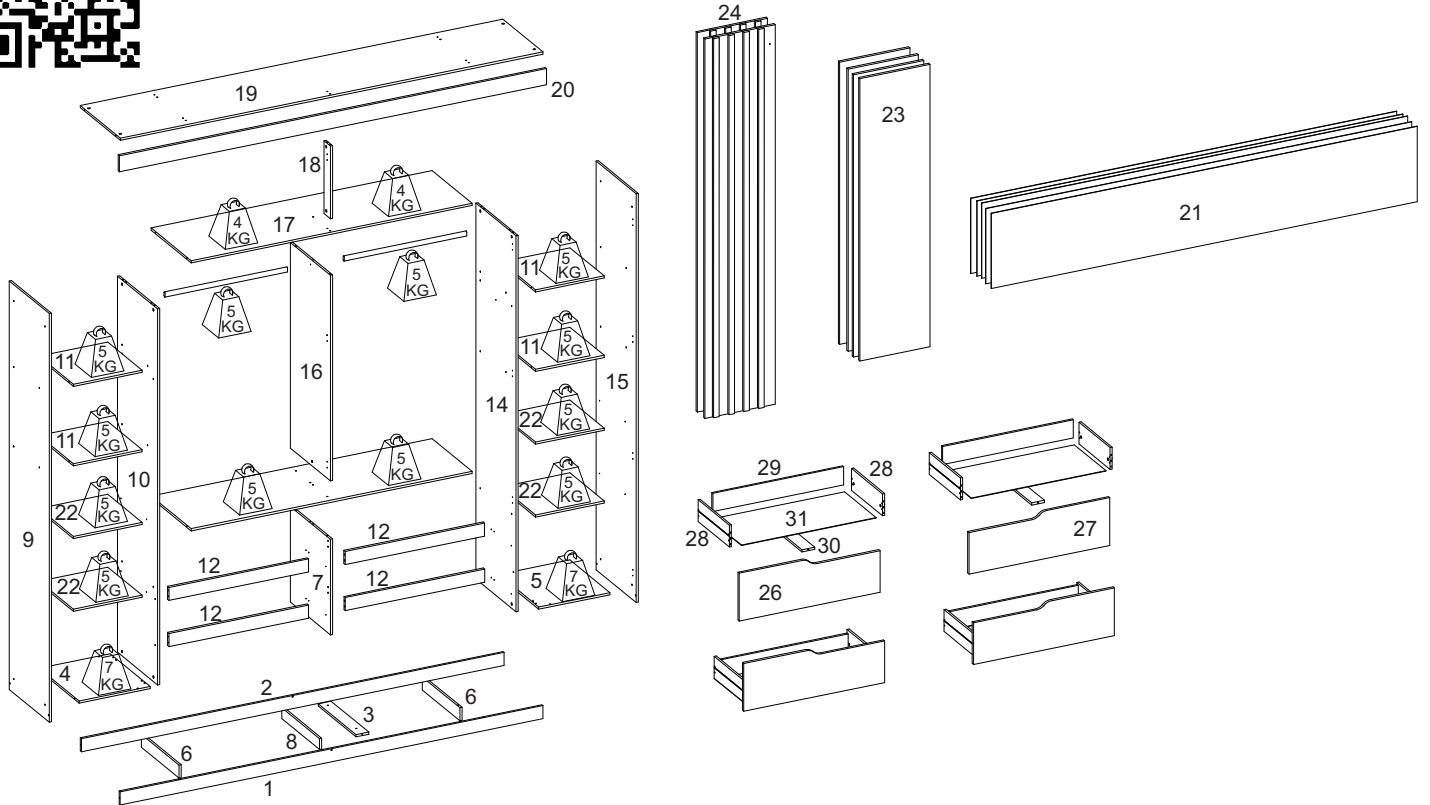

LISTA DE PEÇAS / PIECES LIST / LISTA DE PIEZAS

SEQ.	REF.	DESCRIÇÃO	DESCRIPTION	DESCRIPCIÓN	MAT.PRIMA	COMP.	LARG.	ESP.	QTD.
1	331850	Rodapé frontal	Front footer	Pie de página frontal	MDP	2374	72	12	1
2	331851	Rodapé traseiro	Back footer	Pie de página posterior	MDP	2374	72	12	1
3	331852	Trava divisória	Partition lock	Bloqueo de partición	MDP	424	72	12	1
4	331853	Base esquerda	Left base	base izquierda	MDP	450	400	12	1
5	331854	Base direita	Right base	base derecha	MDP	450	400	12	1
6	331855	Trava rodapé lateral	Side skirting lock	Bloqueo de rodapié lateral	MDP	424	72	12	2
7	331856	Divisória inferior	Lower divider	Divisor inferior	MDP	526	450	12	1
8	331857	Trava rodapé central	Central footer lock	Bloqueo central de pie de página	MDP	424	60	12	1
9	331858	Lateral esquerda	Left side	Lado izquierdo	MDP	2250	450	12	1
10	331859	Divisória esquerda	Left divider	divisor izquierdo	MDP	2070	450	12	1
11	331860	Prateleira superior	Top shelf	estante superior	MDP	386	386	12	4
12	331861	Vista gaveta	Drawer view	Vista del cajón	MDP	783	72	15	4
13	331862	Tampo gaveteiro	Drawer top	Tapa del cajón	MDP	1578	450	12	1
14	331863	Divisória direita	Right divider	divisor derecho	MDP	2070	450	12	1
15	331864	Lateral direita	Right side	Lado derecho	MDP	2250	450	12	1
16	331865	Divisória superior	Upper divider	Divisor superior	MDP	1132	450	12	1
17	331866	Base maleiro	maleiro base	maleiro base	MDP	1578	450	12	1
18	331867	Batente superior	Top stop	parada superior	MDP	400	72	12	1
19	331868	Chapéu	Hat	Sombrero	MDP	2374	450	12	1
20	331869	Vista superior	Upper view	Vista superior	MDP	2398	88	15	1
21	331870	Fundo	Bottom	Abajo	HDF	2392	414	3	5
22	331871	Prateleira móvel	Mobile shelf	Estante móvil	MDP	386	386	12	4
23	331872	Porta	Door	Puerta	MDP	1554	394	15	4
24	331873	Porta lateral ripada	Slatted side door	Puerta lateral de listones	MDP	2089	394	15	2
26	331875	Frente gaveta esquerda	Left drawer front	Frente del cajón izquierdo	MDP	791	263	15	2
27	331876	Frente gaveta direita	Right drawer front	Frente del cajón derecho	MDP	791	263	15	2
28	331877	Lateral de gaveta	Drawer side	Lado del cajón	MDP	350	120	12	8
29	331878	Contra fundo	Against background	Contra el fondo	MDP	734	100	12	4
30	331879	Apoio de gaveta	Drawer support	Soporte de cajón	MDP	350	72	12	4
31	331880	Fundo da gaveta	Drawer bottom	Fondo del cajón	HDF	756	355	3	4

INSTRUÇÃO MONTAGEM PRODUTO
Intructions to Assembly / Instrucciones de montaje

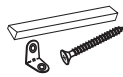

Separe as peças e acessórios de maneira organizada
 Separate parts and accessories in way organized
 Separe las piezas y accesorios de manera organizada

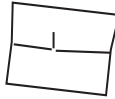

Forrar o chão com o papelão das embalagens.
 Cover the floor with the cardboard
 Cubra el suelo con la embalaje de cartón



É necessário 02 pessoa para montar o produto
 02 people are required to assemble the product
 Se requieren 02 persona para ensamblar el producto

O produto deve ser a montado por um profissional qualificado
 The product must be assembly by a professional
 El producto debe ser ensamblado por un profesional calificado

Ferramentas necessárias
 (não fornecidas)

Not include tools / No herramientas



CUIDADO PARA CONSERVAÇÃO E LIMPEZA DO MÓVEL
Care to conservation and clean / Cuidados de limpieza

Peso máximo de carga informado refere-se a objetos distribuido de maneira uniforme sobre toda área de contato da peça



The maximum load weight informed refers to objects distributed evenly over the entire contact area of the part
 Conjunto de carga máxima de peso se refiere a objetos distribuidos uniformemente sobre toda el área de contacto de la pieza de trabajo.



Não molhar o móvel e não expor em lugar úmido
 Do not wet the mobile and do not expose in a wet place
 No moje el producto y no exponer en un lugar húmedo



Não expor o móvel próximo de fontes de calor.
 Do not expose the mobile near heat sources
 no exponga cercano de fuentes de calor



Não usar produtos abrasivos.
 Do not use abrasive products.
 No utilice productos abrasivos.



Limpe com flanela limpa e seca.
 Clean with dry cloth
 Limpieza con un paño limpio y seco

LISTA DE ACESSÓRIOS E FERRAGENS / ACCESSORIES AND HARDWARE / ACCESORIOS Y HARDWARE

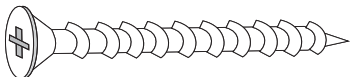

A - 700137- Parafuso 4,5x45 (50x)
 screw / tornillo



B - 700124-Parafuso 3,5x25 (43x)
 screw / tornillo



C - 700121-Parafuso 3,5x12 (172x)
 screw / tornillo



D- 700157-Prego (147x)
 nail / clavo



E - 701091 - Kit com 10 Pes (1x)
 foot / pie



F- 700542-Cavilha 6x30 (30x)
 peg / cerrojo



G- 700146-Parafuso minifix (19x)
 Minifix screw /
 Tornillo minifix



H- 700148-Tambor Minifix (19x)
 Minifix Drum / Tambor minifix



I - 700113-Corrediça (4x)
 runners / corredera



J - 700539-Cantoneira (14x)
 corner / esquina



K - 700127-Parafuso 4,0x12 (80x)
 screw / tornillo



L- 700446 - Porca cilíndrica (4x)
 Cylindrical Nut / Tuerca cilíndrica



M - 700438 - Suporte cabide (4X)
 hook support / soporte gancho



N - - 700361 - Cabideiro Alumínio (2x)
 Coat Rack / Perchero

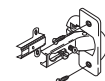

O- 700395 - Dobradiça (20x)
 700390 - Calço (20x)
 hinge / bisagra

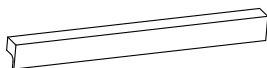

P- 702105-Puxador 600 mm (4x)
 Handle / Manija



Q- 703008 - Perfil H (4x)
 Frame / Perfil



R- 700538 - Cantoneira (4x)
 corner / esquina



S- 700543 - Cavilha 6x60 (7x)
 peg / cerrojo



T - 700441 - Suporte prateleira(16x)
 Support/apoyo



U- 700130 - Parafuso 4,0x16 (16x)
 screw / tornillo



V- -703007 - Puxador 2087 mm (2x)
 Handle / Manija



W- 700516 - Cola (1x)
 glue / pegamento



Y- 700419-Tapa furo (62x)
 cover / tapa

01° PASSO - Fixar os acessórios nas peças 7,10 e 14

01° STEP - Fix the fittings to parts 7,10 and 14

01° PASO - Fijar los accesorios a las piezas 7,10 y 14

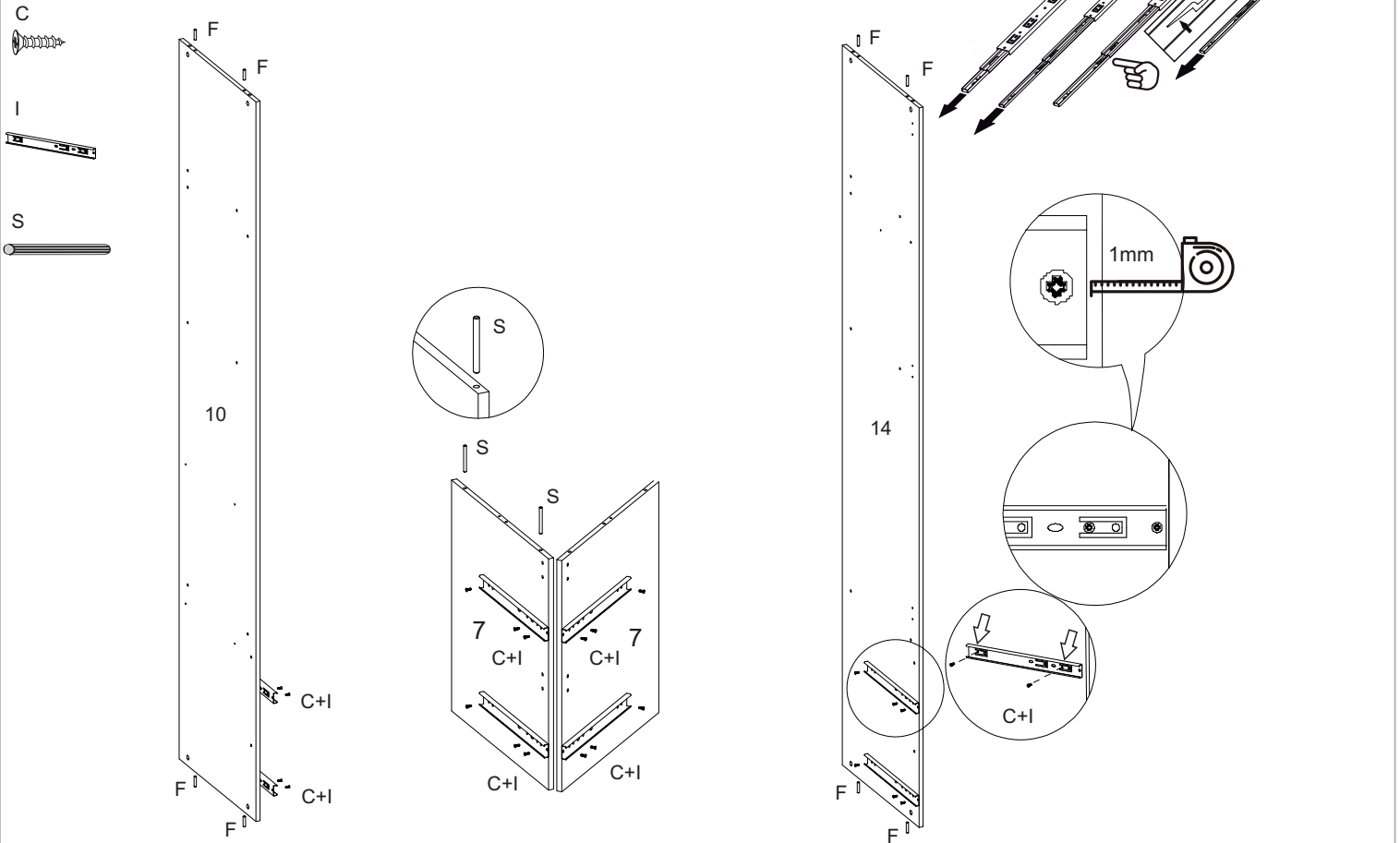

02° PASSO - Fixar peças 1 e 2 na peça 3

02° STEP - Fix parts 1 and 2 to part 3

02° PASO - Fijar las partes 1 y 2 a la parte 3

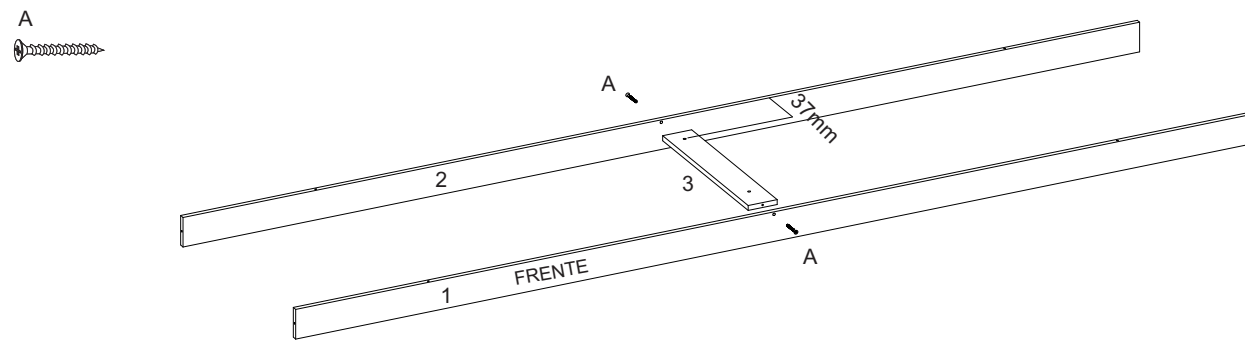

03° PASSO - Fixar peças 4 e 5 nas peças 1 e 2

03° STEP - Fix parts 4 and 5 to parts 1 and 2

03° PASO - Fijar las partes 4 y 5 a las partes 1 y 2

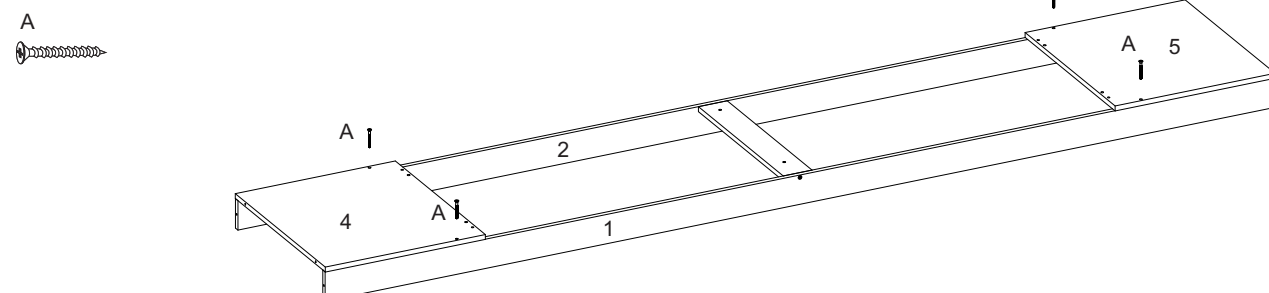

04° PASSO - Fixa a peças 6 e 7 nas peças 1,2 e 3

04° STEP - Fix parts 6 and 7 to parts 1, 2 and 3

04° PASO - Fijar las partes 6 y 7 a las partes 1, 2 y 3

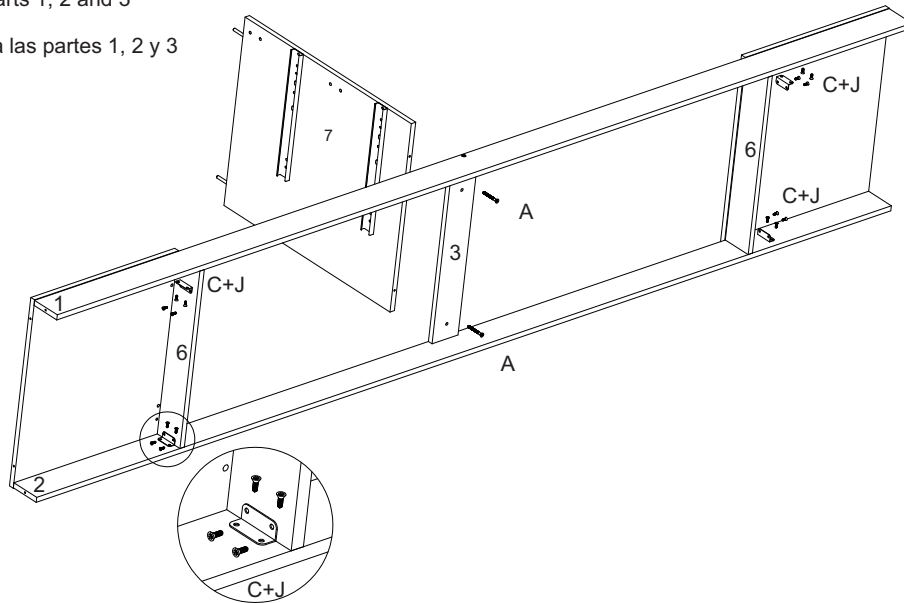

05° PASSO - Fixar peça 8 nas peça 3

05° STEP - Fix part 8 to part 3

05° PASO - Fijar la parte 8 a la parte 3

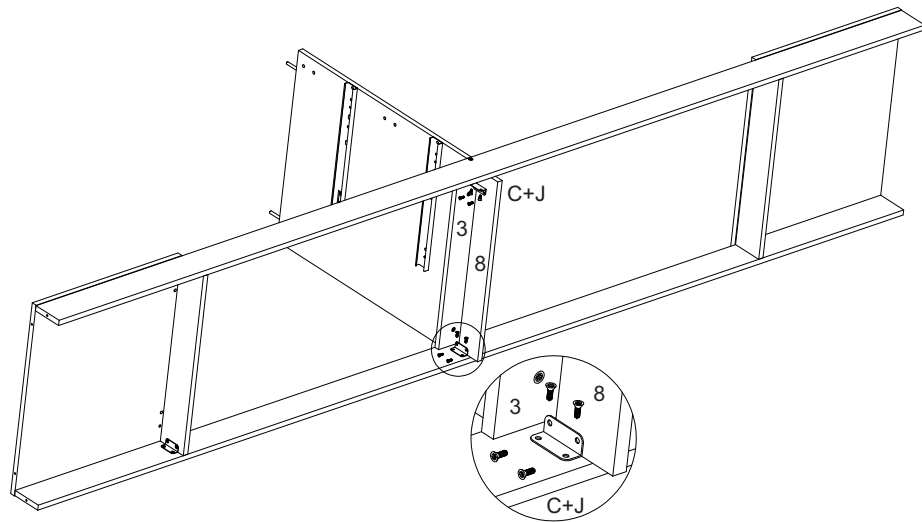

06° PASSO - Fixar o kit pé

06° STEP - Fix the foot kit

06° PASO - Fijación del kit de pies

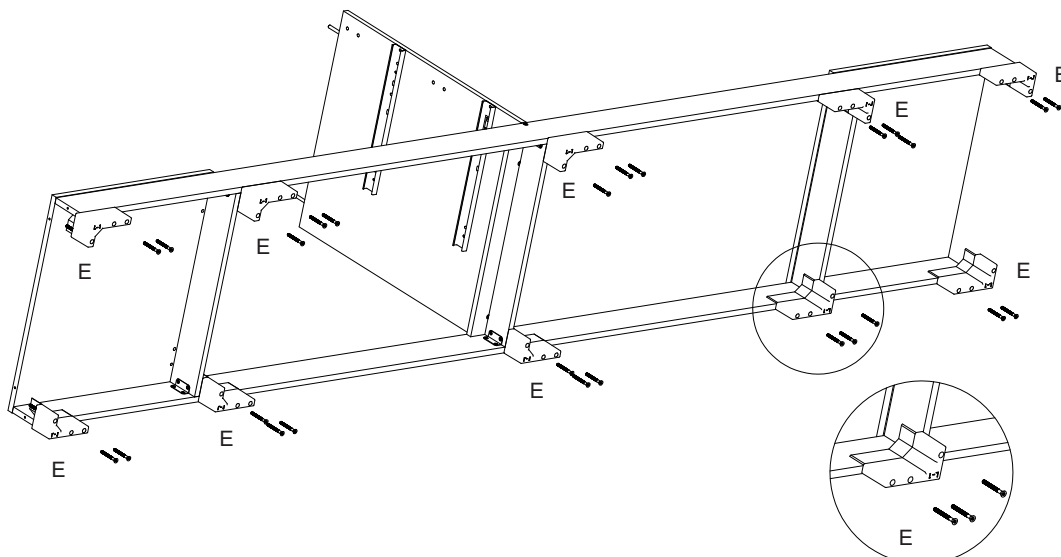
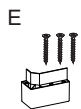

07° PASSO - Fixar peça 9 nas peças 1,2 e 4

07° STEP - Fix part 9 to parts 1, 2 and 4

07° PASO - Fijar la parte 9 a las partes 1, 2 y 4

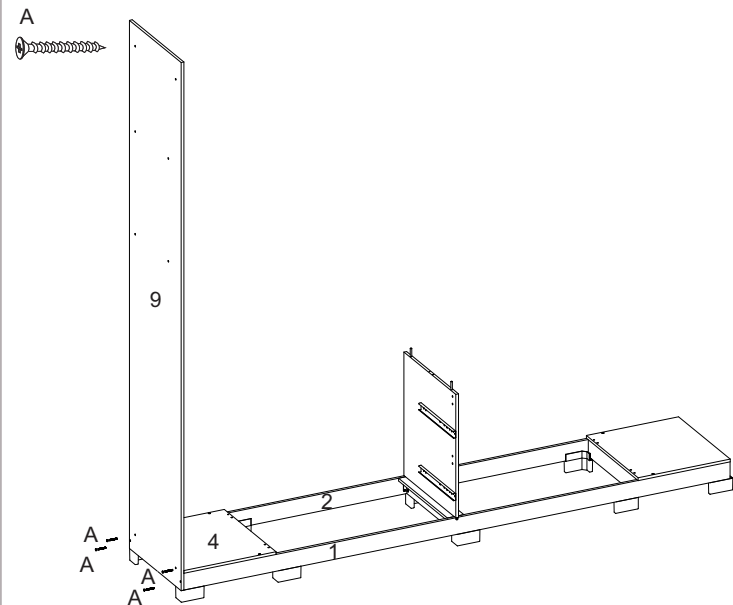

08° PASSO - Fixar peça 10 na peça 4

08° STEP - Fix part 10 to part 4

08° PASO - Fijar la parte 10 con la parte 4

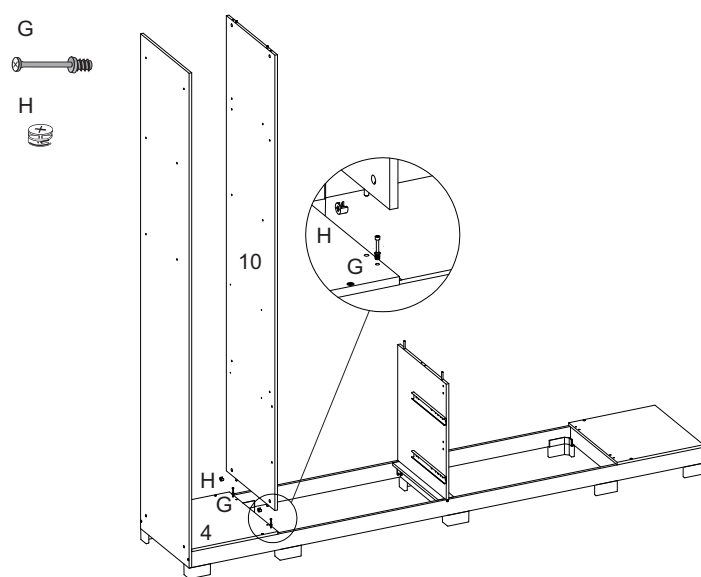

09° PASSO - Fixar peças 11 nas peças 9 e 10

09° STEP - Fix parts 11 to parts 9 and 10

09° PASO - Fijar la pieza 11 a las piezas 9 y 10.

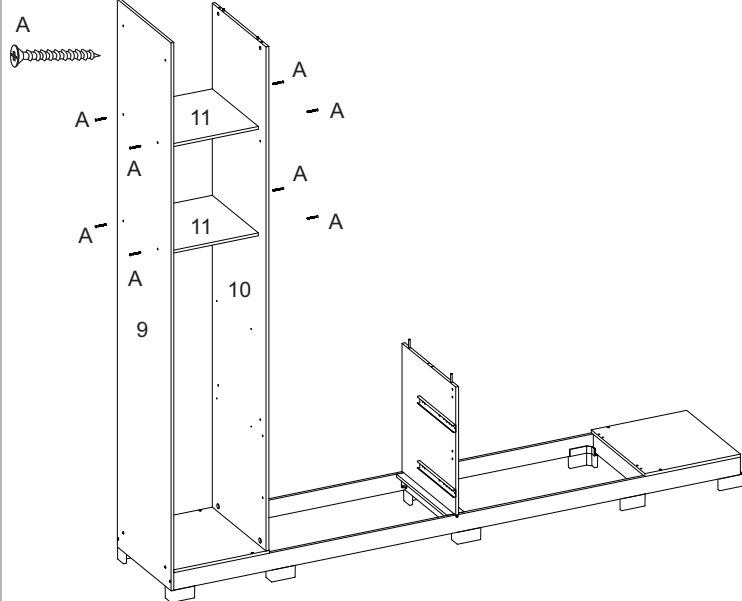

10° PASSO - Fixar peça 10 nas peças 12

10° STEP - Fix parts 10 to parts 12

10° PASO - Fijar las pieza 10 a las piezas 12

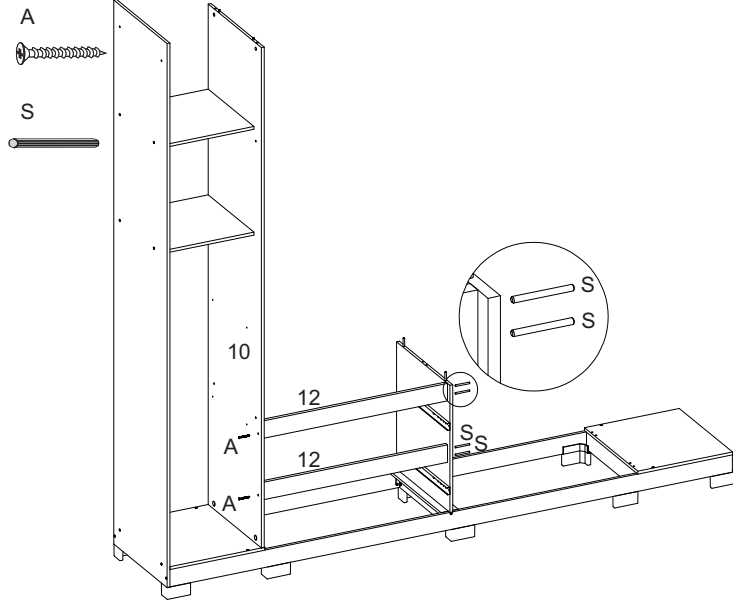

11° PASSO - Fixar peça 14 nas peça 5

11° STEP - Fix part 14 to part 5

11° PASO - Fijar la pieza 14 a las pieza 5

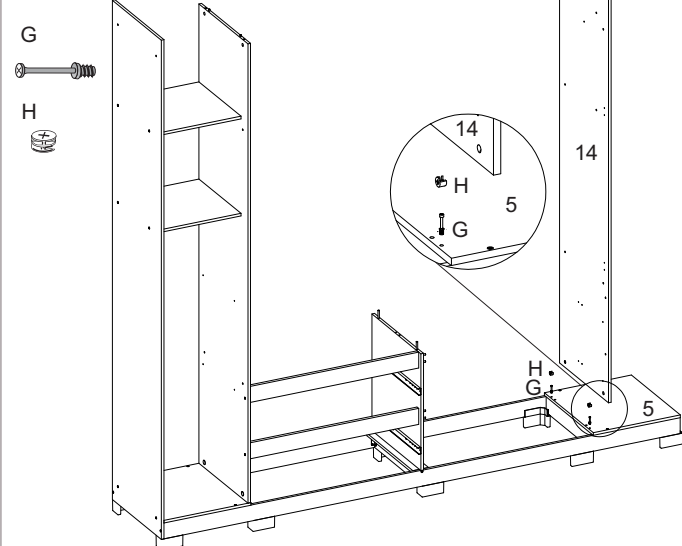

12° PASSO - Fixar peças 12 nas peças 7 e 14

12° STEP - Fix parts 12 to parts 7 and 14

12° PASO - Fijar la pieza 12 a las piezas 7 y 14.

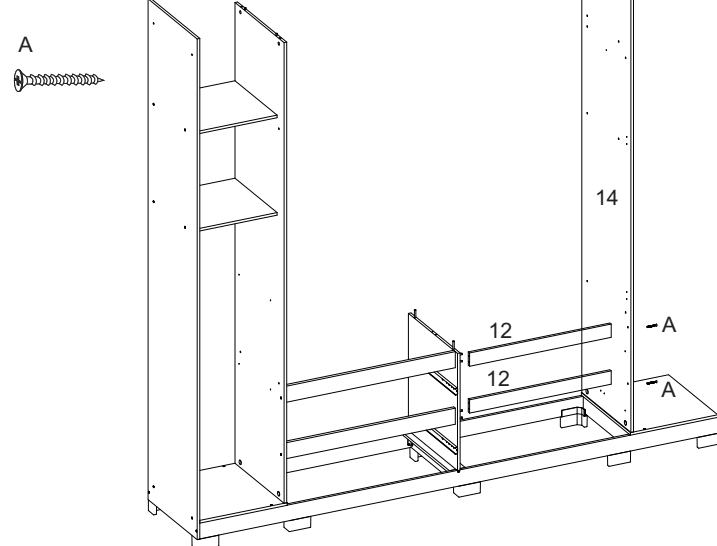

13° PASSO - Fixar peças 11 e 15 nas peças 1,2,5 e 14

13° STEP - Fix parts 11 and 15 to parts 1,2,5 and 14.

13° PASO - Fijar las piezas 11 y 15 a las piezas 1,2,5 y 14.

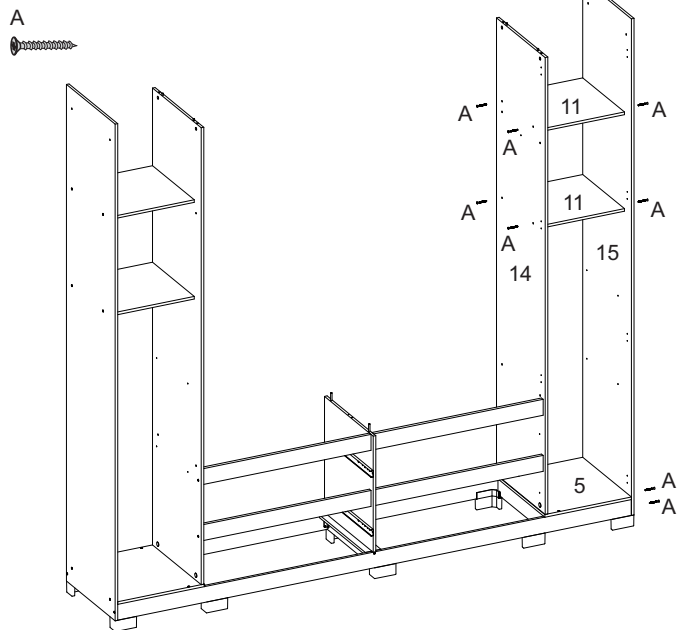

14° PASSO - Fixar a peça 13 nas peças 10 e 14

14° STEP - Fix part 16 to parts 6, 8 and 15

14° PASO - Fijar la parte 16 a las partes 6, 8 y 15

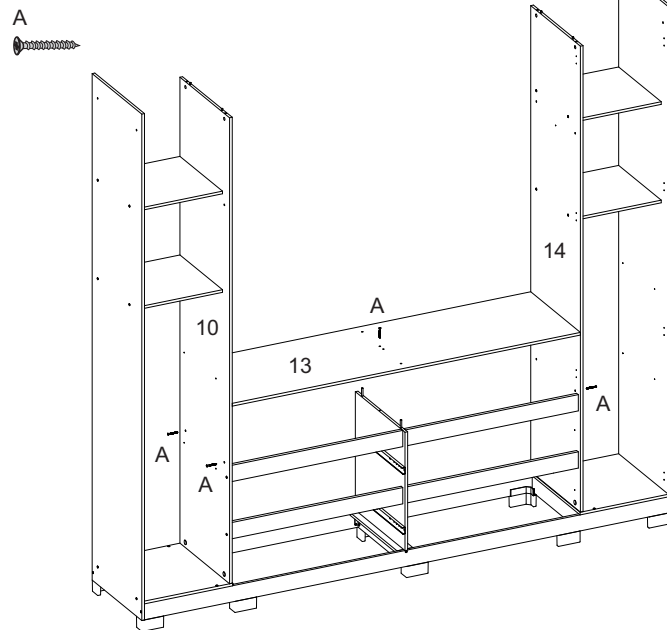

15° PASSO - Fixar peça 16 na peça 13

15° STEP - Fix part 16 to part 13

15° PASO - Fijar la parte 16 a la parte 13

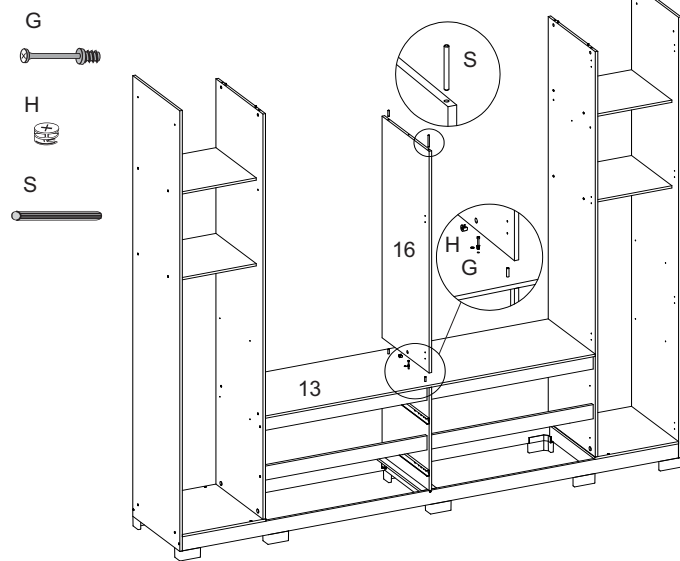

16° PASSO - Fixar peça 17 nas peças 10,14 e 16

16° STEP - Fix part 17 to parts 10, 14 and 16

16° PASO - Fijar la parte 17 a las partes 10, 14 y 16

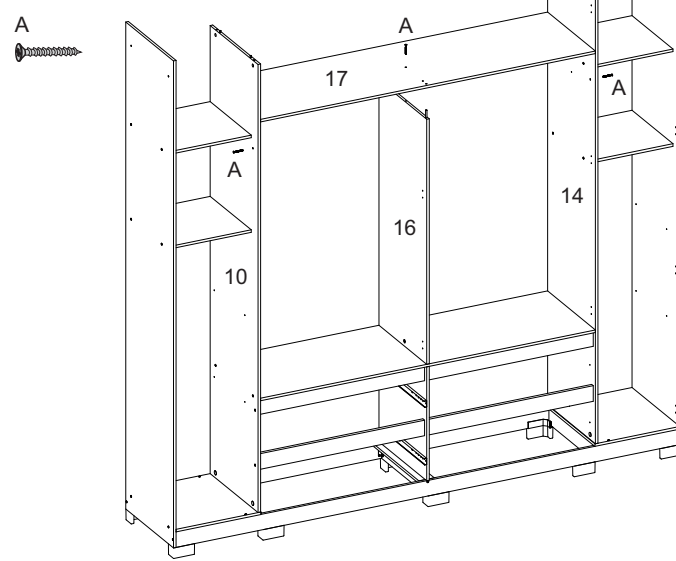

17° PASSO - Fixar peça 18 na peça 17

17° STEP - Fix part 18 to part 17

17° PASO - Fijar la parte 18 a la parte 17

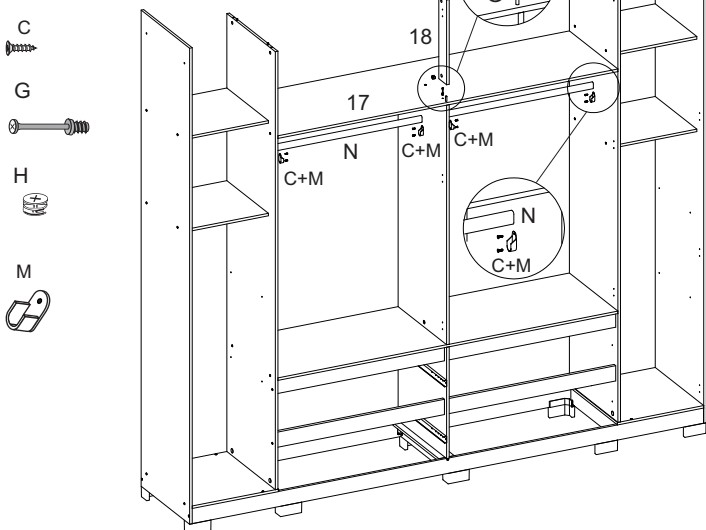

18° PASSO - Fixar peça 19 nas peças 9,10,14,,15 e 18

18° STEP - Fix part 19 to parts 9, 10, 14, 15 and 18

18° PASO - Fijar la pieza 19 a las piezas 9, 10, 14, 15 y 18

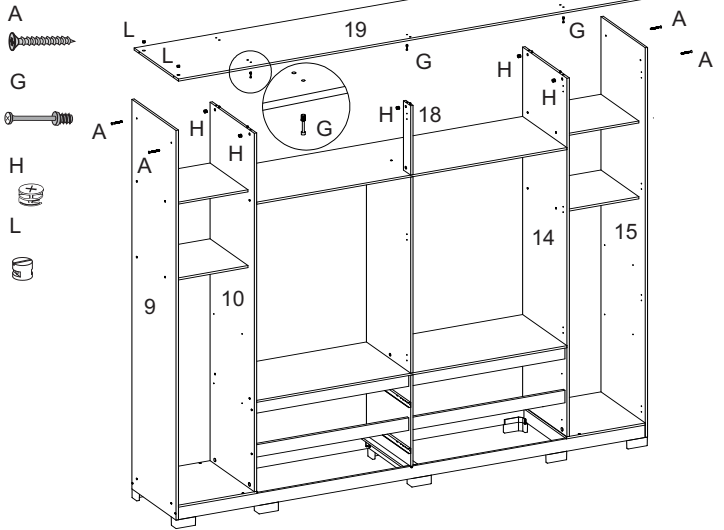

19° PASSO - Fixar peças 21 na parte de trás do produto

19° STEP - Fix parts 21 to the back of the product

19° PASO - Fijar las piezas 21 en la parte posterior del producto

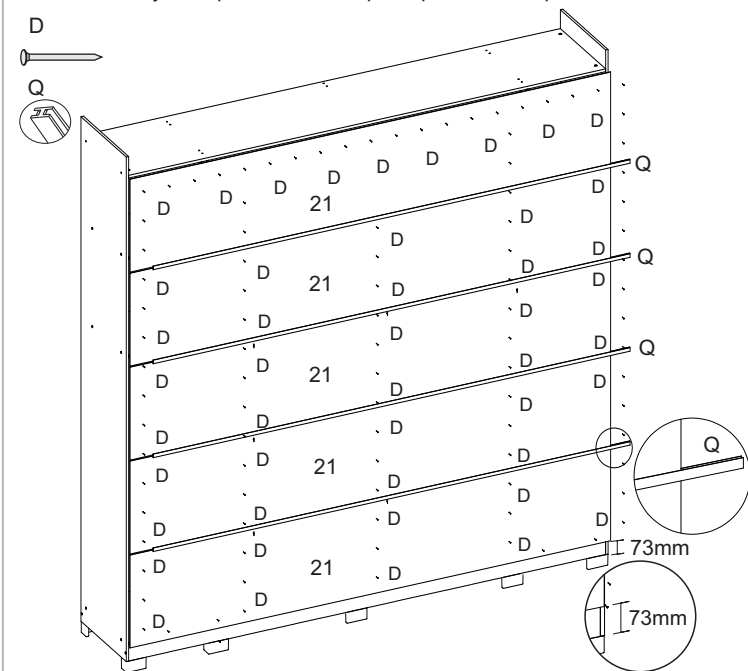

20° PASSO - Fixar peça 20 nas peças 9, 15 e 19

20° STEP - Fix parts 20 to parts 18/19 and 21

20° PASO - Fijar las piezas 20 con las piezas 18/19 y 21

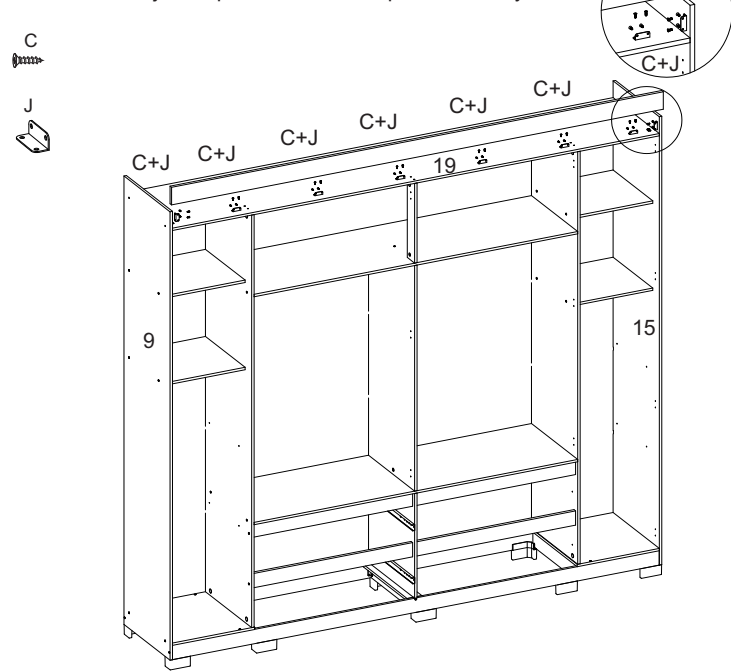

21° PASSO - Encaixar peças 22 nas peças 9, 10, 14 e 15

21° STEP - Fix part 23 to parts 20 and 21

21° PASO - Encajar las piezas 22 con las piezas 9, 10, 14 y 15

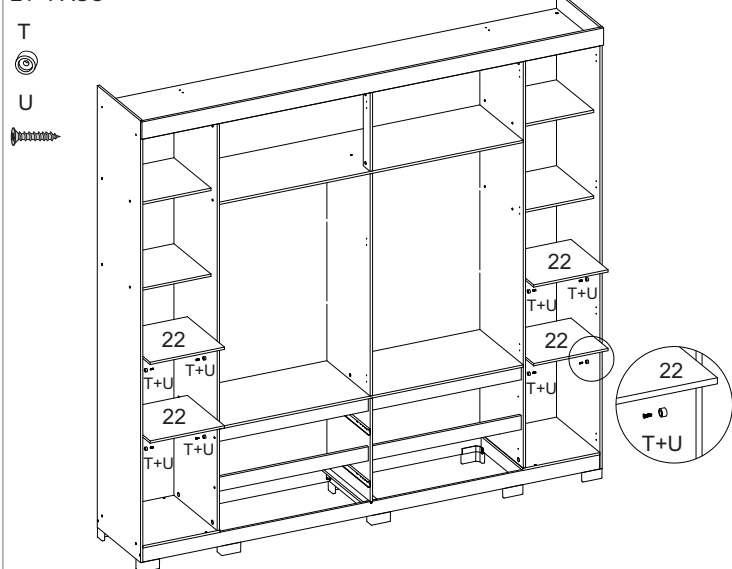

22° PASSO - Fixar peças 28 nas peças 26/27 e 29

22° STEP - Fix parts 28 to parts 26/27 and 29

22° PASO - Fijar las piezas 28 a las piezas 26/27 y 29

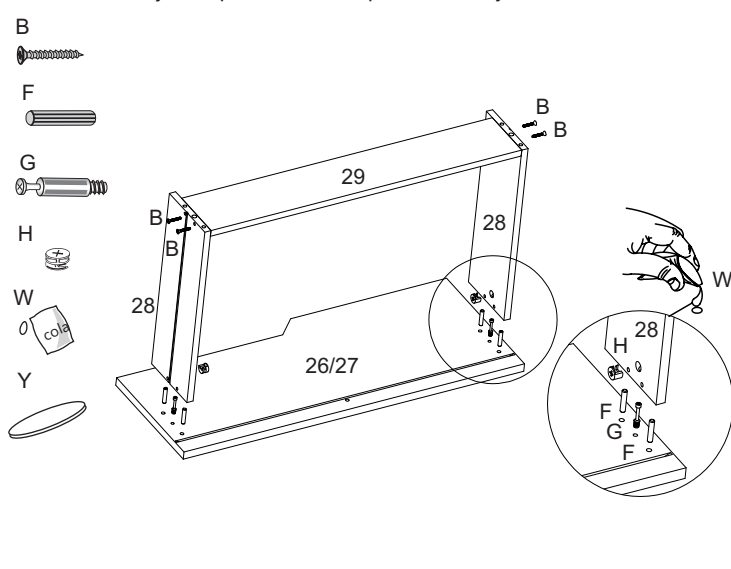

23° PASSO - Fixar peça 23 nas peças 28 e 29

23° STEP - Fix part 23 to parts 28 and 29

23° PASO - Fijar la parte 23 a las partes 28 y 29

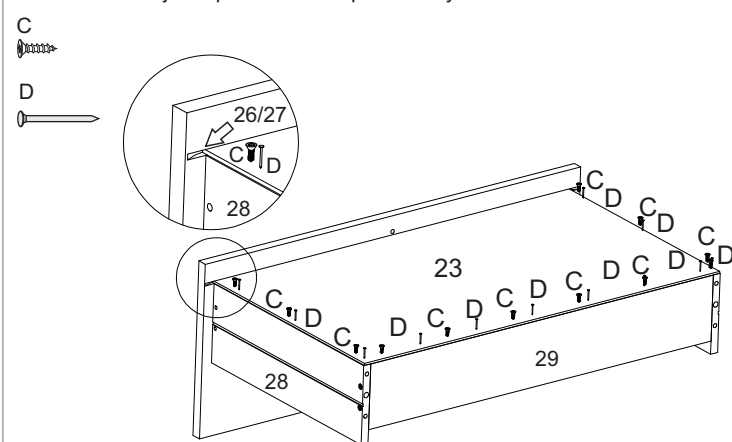

24° PASSO - Fixar peça 30 nas peças 29

24° STEP - Fix part 30 to part 29

24° PASO - Fijar la parte 30 a las parte 29

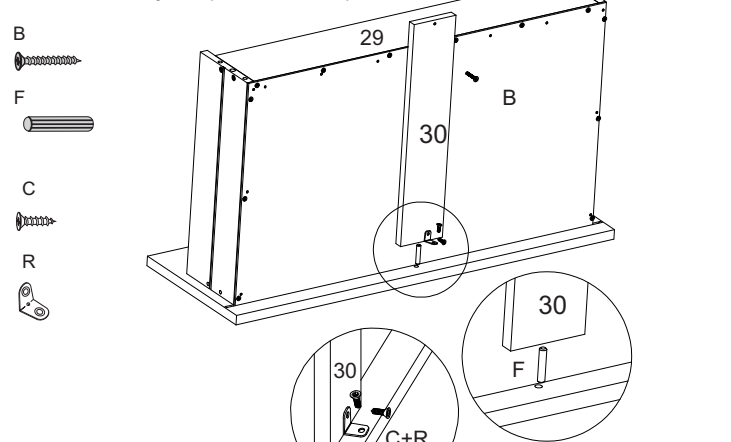

25° PASSO - Fixar os acessórios nas peças 28

25° STEP - Fix accessories to parts 28

25° PASO - Fijar accesorios en las piezas 28

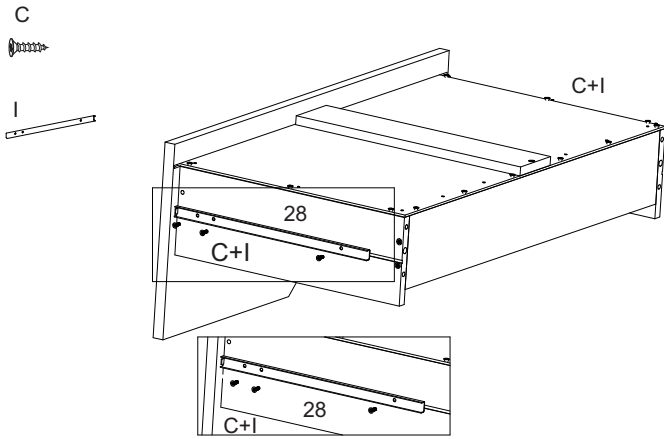

26° PASSO - Encaixar as gaveta no produto

26° STEP - Insert the drawers in the product

26° PASO - Introducir los cajones en el producto

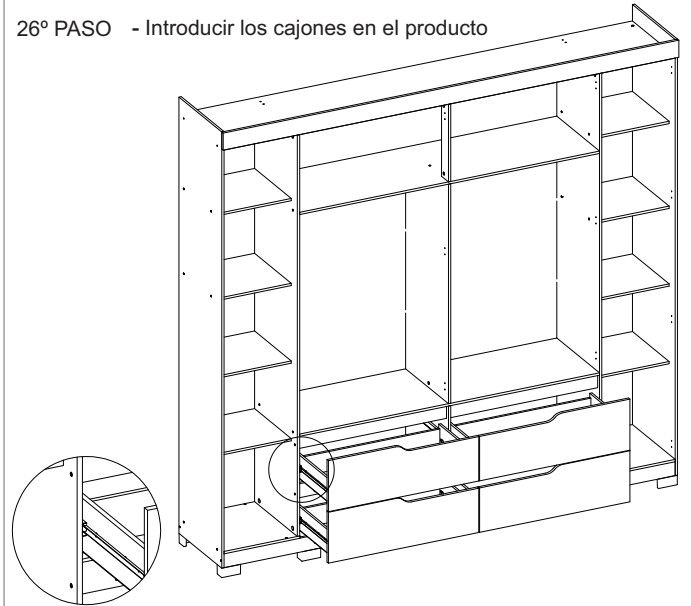

27° PASSO - Fixar acessórios K+O nas peças 23

27° STEP - Fix K+O fittings to parts 23

27° PASO - Fijar los accesorios K+O en las piezas 23

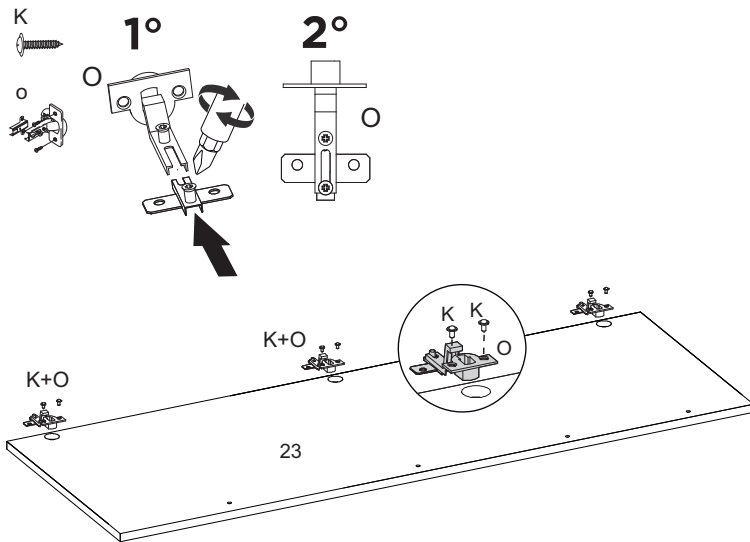

28° PASSO - Fixar peças 23 nas peças 10, 14 e 16

28° STEP - Fix parts 23 to parts 10, 14 and 16

28° PASO - Fijar las piezas 23 a las piezas 10, 14 y 16

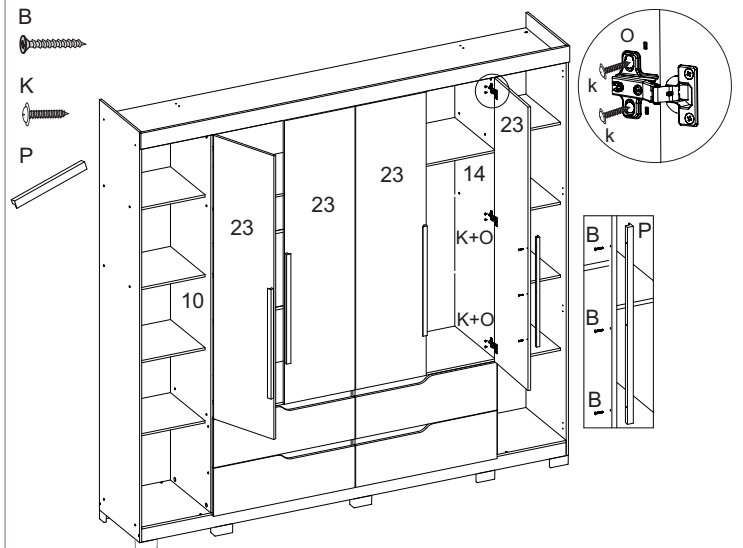

29° PASSO - Fixar acessórios K+O nas peças 24

29° STEP - Fix K+O fittings to parts 24

29° PASO - Fijar los accesorios K+O en las piezas 24

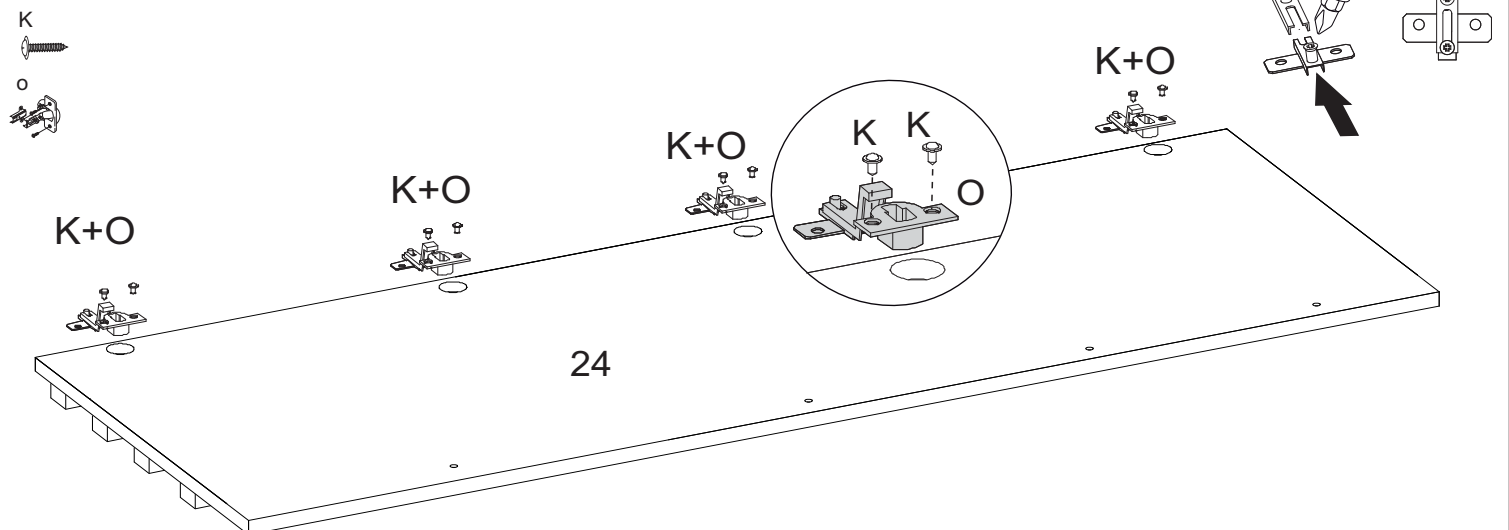

30° PASSO - Fixar peças 24 nas peças 9 e 15

30° STEP - Fix parts 24 to parts 9 and 15

30° PASO - Fijar las piezas 24 a las piezas 9 y 15

B



K



V

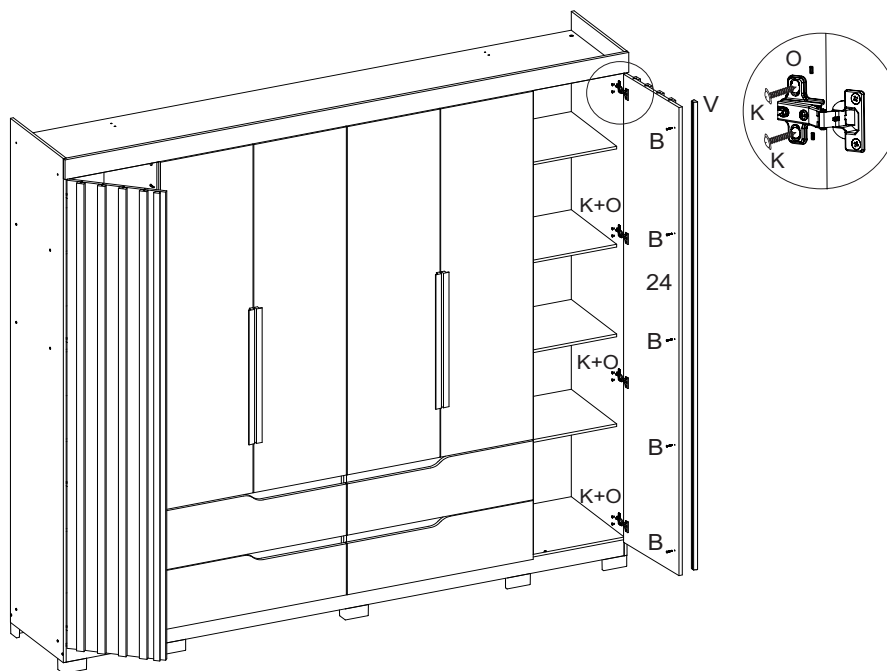

Aspecto final do produto

Aspecto final del producto.

Final appearance of the product

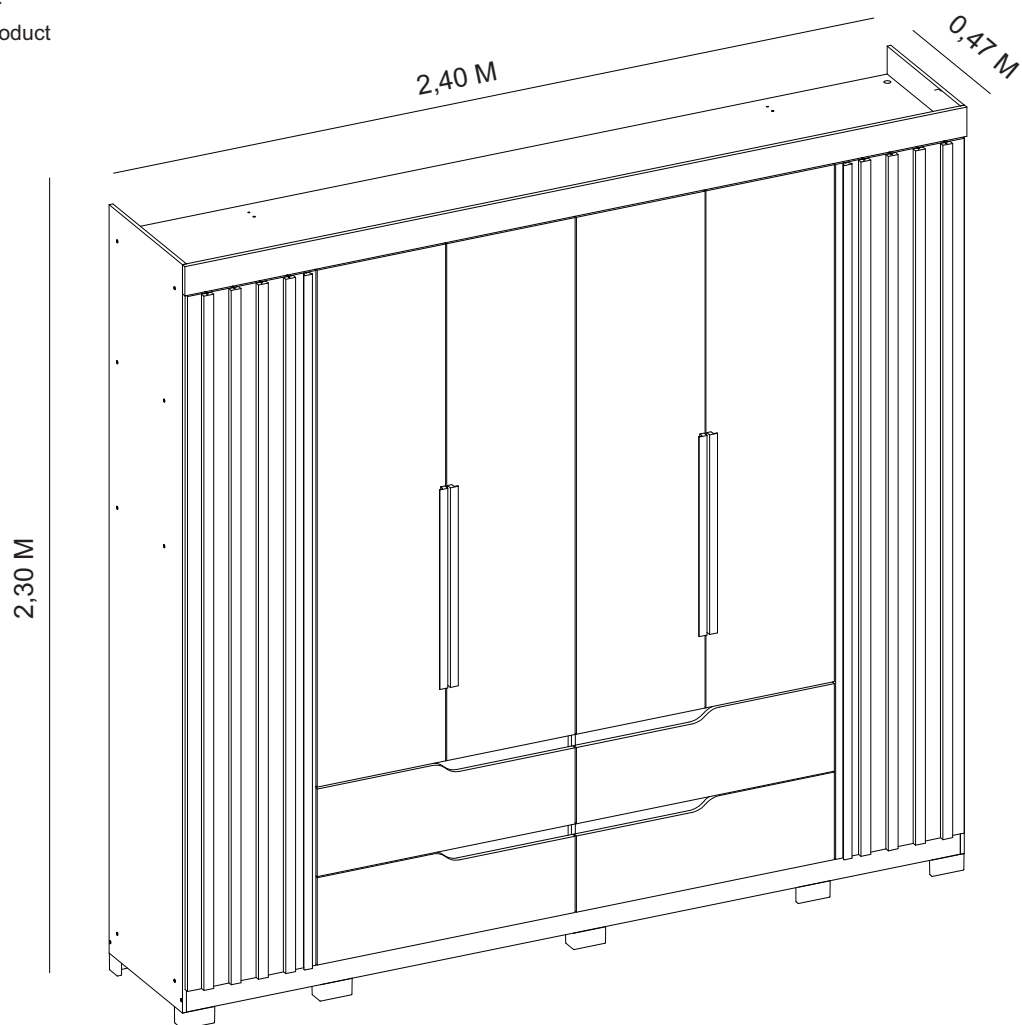

MONTAGEM PARA O PRODUTO QUE CONTEM ESPELHO
ASSEMBLY FOR THE PRODUCT THAT CONTAINS MIRROR
MONTAJE DEL PRODUCTO QUE CONTIENE ESPEJO

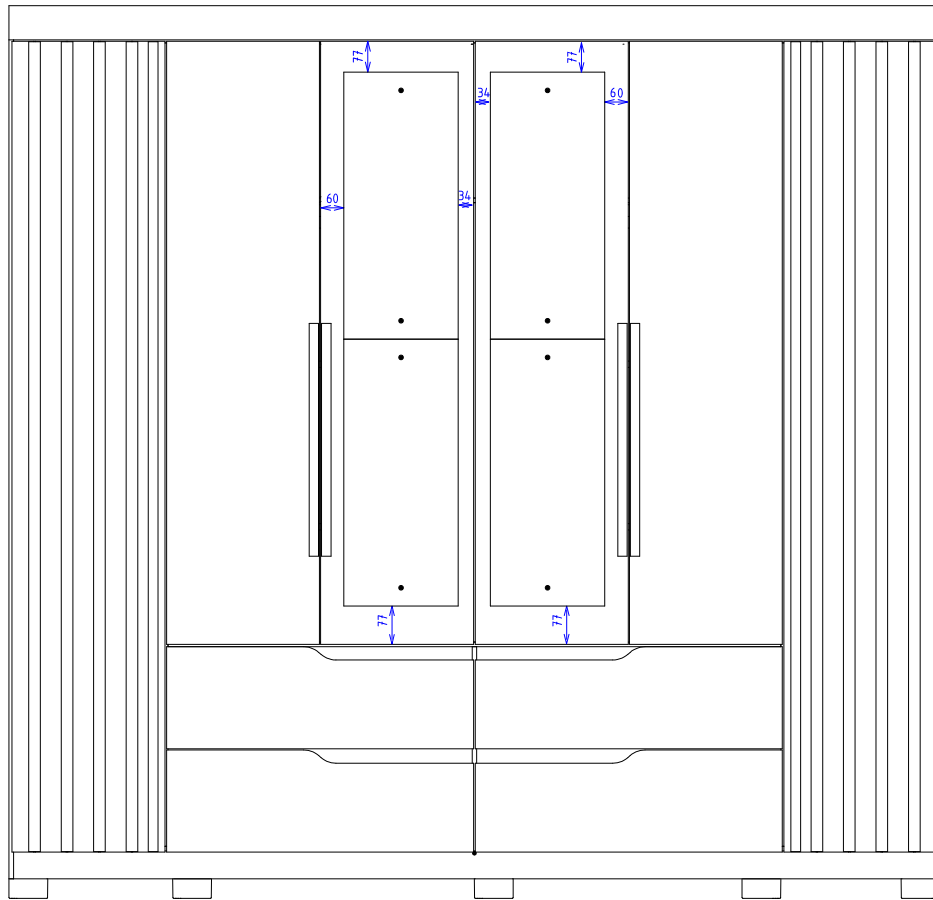

Agora que você já comprou o seu móvel, ele merece ser montado do jeito certo.

Erros de montagem causam mais de **60%** dos danos em móveis.

Por que contratar?

Tranquilidade do **início ao fim** da montagem



PROFISSIONAIS QUALIFICADOS

Especialistas certificados na **MadeiraMadeira Serviços**.



FERRAMENTAS PROFISSIONAIS

que **protegem** seus móveis.



AGENDAMENTO EM 24 HORAS

escolha a data e o turno **ideais para** você.



GARANTIA DE 3 MESES

de cobertura **completa**.

Mais de 1 MILHÃO DE MONTAGENS
★ com avaliação **4.7** ★

Mariana S., São Paulo

"Chegaram no horário e montaram tudo rapidamente. Serviço incrível!"



Carlos R., Belo Horizonte

"Tentei montar sozinho e foi um desastre. Com a **MadeiraMadeira Serviços** ficou perfeito."



Ana P., Rio de Janeiro

"Agendamento ágil e **montagem pontual e perfeita**. Recomendo demais!"



Agende agora pelo QR Code

Madeira**Madeira** Serviços · Atendimento em todo o Brasil



Escaneie o QRCode