

190 - CÔMODA SAPATEIRA DUETTO

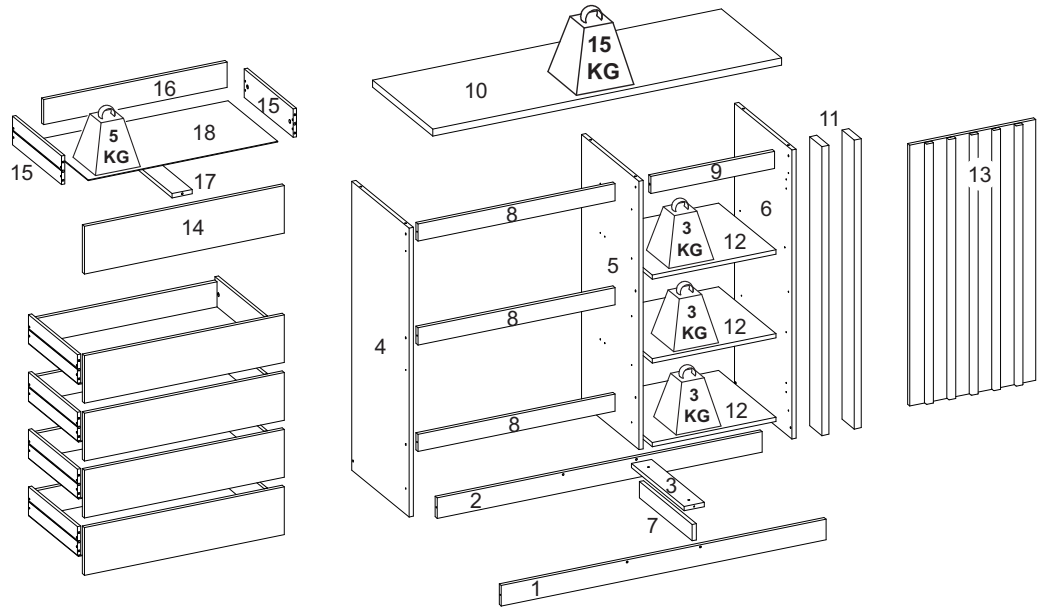

|    LISTA DE PEÇAS / Pieces List / Lista de Piezas | | | | | | | | | |
|--|--------|-------------------|--------------------|--------------------------|-----------|-------|-------|------|------|
| SEQ. | REF. | DESCRIÇÃO | DESCRIPTION | DESCRIPCIÓN | MAT.PRIMA | COMP. | LARG. | ESP. | QTD. |
| 1 | 331712 | Rodapé frontal | Front footer | Pie de página frontal | MDP | 1158 | 72 | 15 | 1 |
| 2 | 331713 | Rodapé traseiro | Back footer | Pie de página posterior | MDP | 1158 | 72 | 15 | 1 |
| 3 | 331714 | Trava divisória | Partition lock | Bloqueo de partición | MDP | 377 | 72 | 15 | 1 |
| 4 | 331715 | Lateral esquerda | Left side | Lado izquierdo | MDP | 1012 | 410 | 15 | 1 |
| 5 | 331716 | Divisória | Divider | Divisor | MDP | 940 | 410 | 15 | 1 |
| 6 | 331717 | Lateral direita | Right side | Lado derecho | MDP | 1012 | 410 | 15 | 1 |
| 7 | 331718 | Trava rodapé | Footer lock | Bloqueo de pie de página | MDP | 377 | 57 | 15 | 1 |
| 8 | 331719 | Vista gaveta | Drawer view | Vista del cajón | MDP | 704 | 60 | 15 | 3 |
| 9 | 331720 | Vista porta | Door view | Vista de la puerta | MDP | 439 | 60 | 15 | 1 |
| 10 | 331721 | Tampo | Cover | Cubrir | MDP | 1243 | 430 | 25 | 1 |
| 11 | 331722 | Vista lateral | Side view | Vista lateral | MDP | 1012 | 88 | 25 | 2 |
| 12 | 331723 | Prateleira móvel | Mobile shelf | Estante móvil | MDP | 439 | 410 | 15 | 3 |
| 13 | 331931 | Porta ripada | Slatted door | Puerta de listones | MDP | 913 | 450 | 30 | 1 |
| 14 | 331725 | Frente de gaveta | Drawer front | Frente del cajón | MDP | 714 | 167 | 15 | 5 |
| 15 | 331726 | Lateral de gaveta | Drawer side | Lado del cajón | MDP | 350 | 100 | 12 | 10 |
| 16 | 331727 | Contra fundo | Against background | Contra el fondo | MDP | 655 | 88 | 15 | 5 |
| 17 | 331728 | Apoio de gaveta | Drawer support | Soporte de cajón | MDP | 350 | 72 | 15 | 5 |
| 18 | 331729 | Fundo da gaveta | Drawer bottom | Fondo del cajón | HDF | 677 | 355 | 3 | 5 |
| 19 | 331730 | Fundo | Bottom | Abajo | HDF | 1182 | 326 | 3 | 3 |

INSTRUÇÃO MONTAGEM PRODUTO
 Instructions to Assembly / Instrucciones de montaje

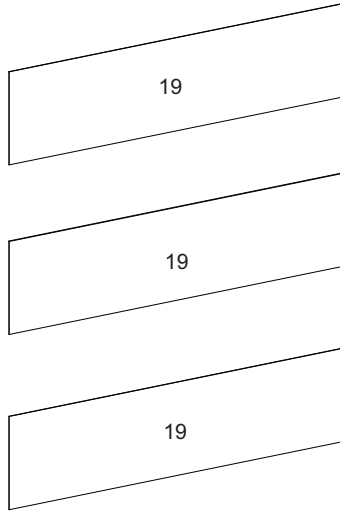
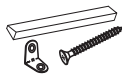

Separe as peças e acessórios de maneira organizada
 Separate parts and accessories in way organized
 Separe las piezas y accesorios de manera organizada

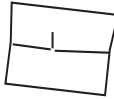

Forrar o chão com o papelão das embalagens.
 Cover the floor with the cardboard
 Cubra el suelo con la embalaje de cartón



É necessário 1 pessoa para montar o produto
 01 people are required to assemble the product
 Se requieren 01 persona para ensamblar el producto

O produto deve ser a montado por um profissional qualificado
 The product must be assembly by a professional
 El producto debe ser ensamblado por un profesional calificado

Ferramentas necessárias
 (não fornecidas)

Not include tools / No herramientas



CUIDADO PARA CONSERVAÇÃO E LIMPEZA DO MÓVEL
 Care to conservation and clean / Cuidados de limpieza

Peso máximo de carga informado refere-se a objetos distribuido de maneira uniforme sobre toda área de contato da peça



The maximum load weight informed refers to objects distributed evenly over the entire contact area of the part
 Conjunto de carga máxima de peso se refiere a objetos distribuidos uniformemente sobre toda el área de contacto de la pieza de trabajo.



Não molhar o móvel e não expor em lugar úmido
 Do not wet the mobile and do not expose in a wet place
 No moje el producto y no exponer en un lugar húmedo



Não expor o móvel próximo de fontes de calor.
 Do not expose the mobile near heat sources
 no exponga cercano de fuentes de calor



Não usar produtos abrasivos.
 Do not use abrasive products.
 No utilice productos abrasivos.



Limpe com flanela limpa e seca.
 Clean with dry cloth
 Limpieza con un paño limpio y seco

LISTA DE ACESSÓRIOS E FERRAGENS / ACCESSORIES AND HARDWARE / ACCESORIOS Y HARDWARE



A- 700137-Parafuso 4,5x45 (12x)
 screw / tornillo



B- 700124-Parafuso 3,5x25 (46x)
 screw / tornillo



C- 700121-Parafuso 3,5x12 (182x)
 screw / tornillo



D- 700129-Parafuso 4,0x14 (12x)
 screw / tornillo



E- 700130-Parafuso 4,0x16 (04x)
 screw / tornillo



F- 700146-Parafuso minifix (10x)
 Minifix screw /
 Tornillo minifix



G- 700148-Tambor Minifix (10x)
 Minifix Drum /
 Tambor minifix



H- 700542-Cavilha 6x30 (39x)
 peg / cerrojo



I- 700157-Prego (97x)
 nail / clavo



J- 701333-Dobradiça
 c/ pistão + calço (04x)
 hinge / bisagra



K- 700516-Sache cola 20g (01x)
 Glue / Goma



L- 700441-Suporte prateleira(08x)
 shelf support/soporte de estanteria



M- 702883-Perfil H (02x)
 Frame / Perfil



N- 700538-Cantoneira (05x)
 corner / esquina



O-700490 - 1 Kit com 6 pes (01x)
 wardrobe feet / alfiler de piso



P - 700113-Corrediça (05x)
 runners / corredera



Q- 700539-Cantoneira (13x)
 corner / esquina



R- 700419-Tapa furo minifix (22x)
 cover / tapa

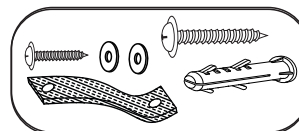

S- 703012 - Kit anti tonbamento (01x)
 Anti-tip kit / Kit antivuelco

01° PASSO - Fixar os acessórios nas peças 4,5 e 6

01° STEP - Fix accessory to parts 4,5 and 6

01° PASO - Fijar el accesorio las partes 4,5 y 6

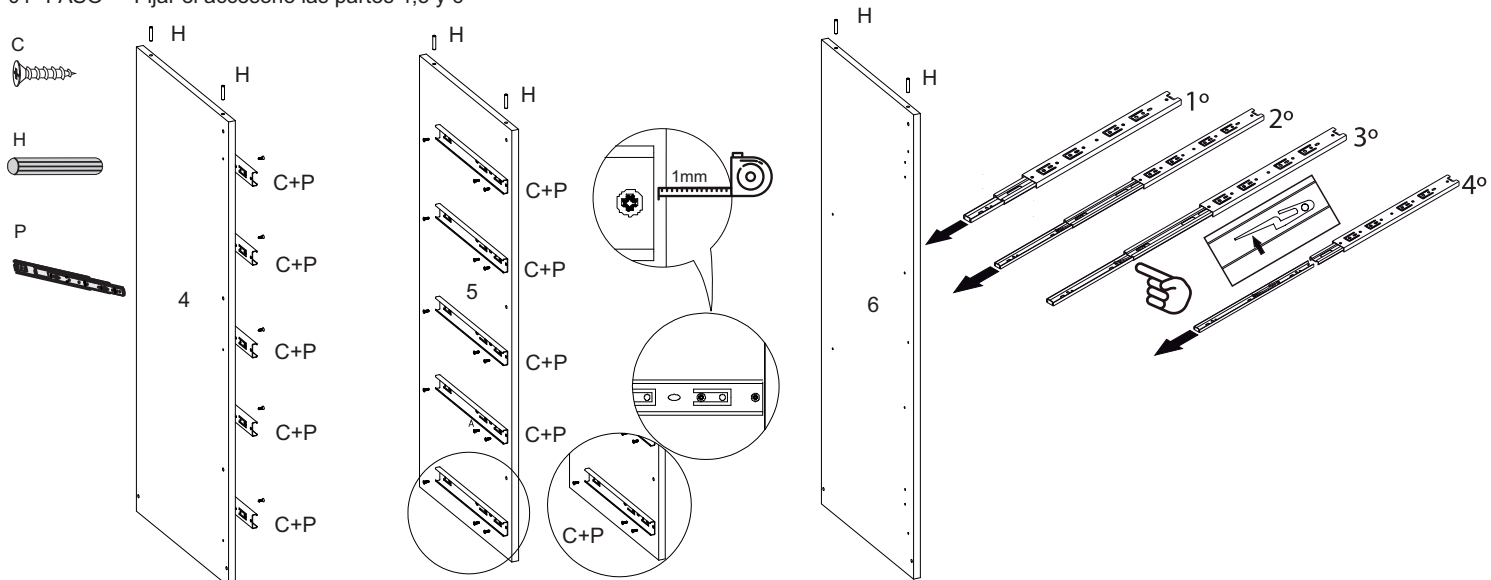

02° PASSO - Fixar peça 3 nas peças 1 e 2

02° STEP - Fix part 3 to parts 1 and 2

02° PASO - Fijar la pieza 3 a las piezas 1 y 2.

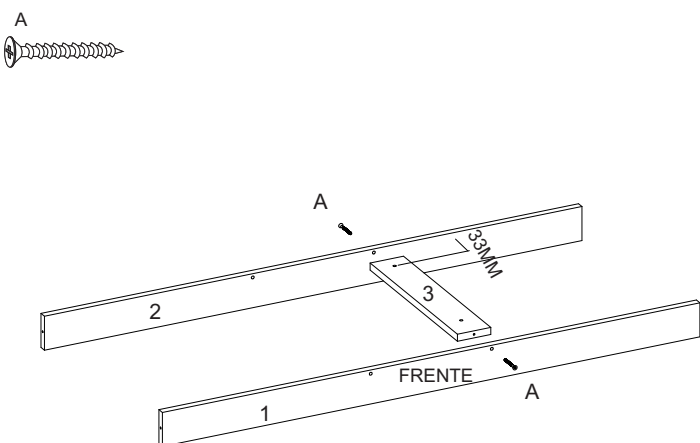

03° PASSO - Fixar as peças 4,5 e 6 nas peças 1,2 e 3

03° STEP - Fijar parts 4,5 and 6 to parts 1,2 and 3

03° PASO - Fijar las piezas 4,5 y 6 a las piezas 1,2 y 3.

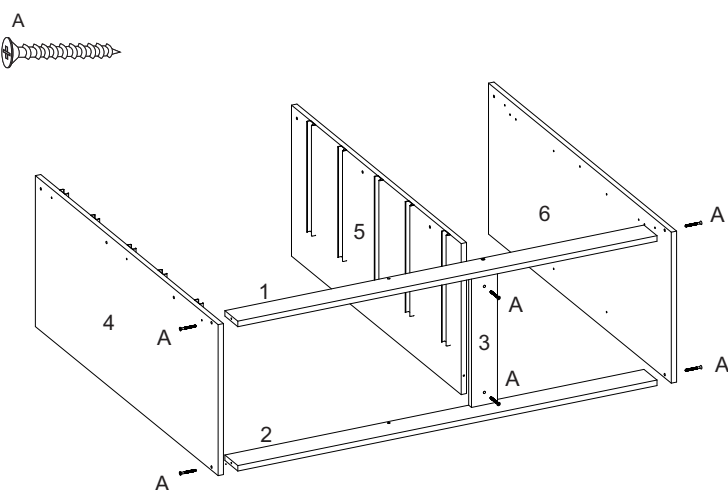

04° PASSO - Fixar a peça 7 nas peça 1 e 2

04° STEP - Fix parts 7 to parts 1 and 2

04° PASO - Fijar la pieza 7 a las partes 1 y 2

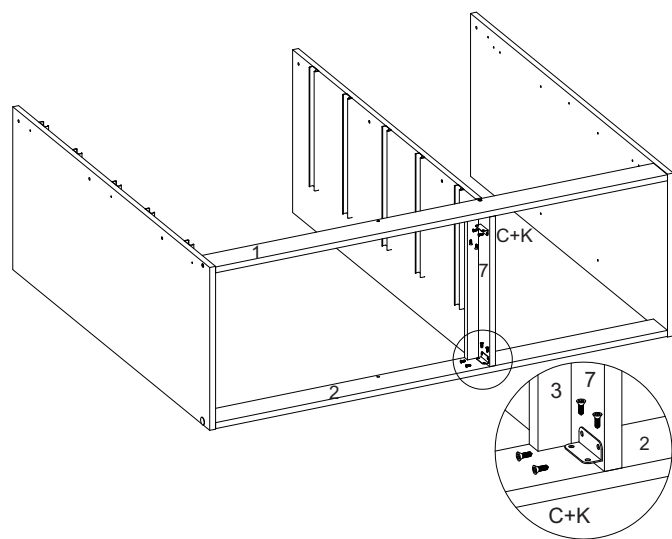

05° PASSO - Fixar o Kit pé

05° STEP - Fix the Foot Kit

05° PASO - Fijar el kit de pies

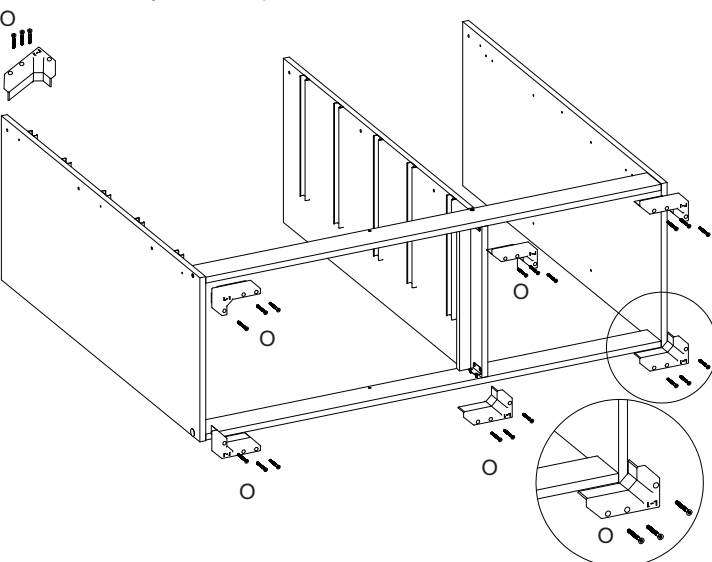

06° PASSO - Fixar peças 8 e 9 nas peças 4,5 e 6

06° STEP - Fix parts 8 and 9 to parts 4,5 and 6

06° PASO - Fijar las piezas 8 y 9 a las piezas 4,5 y 6.

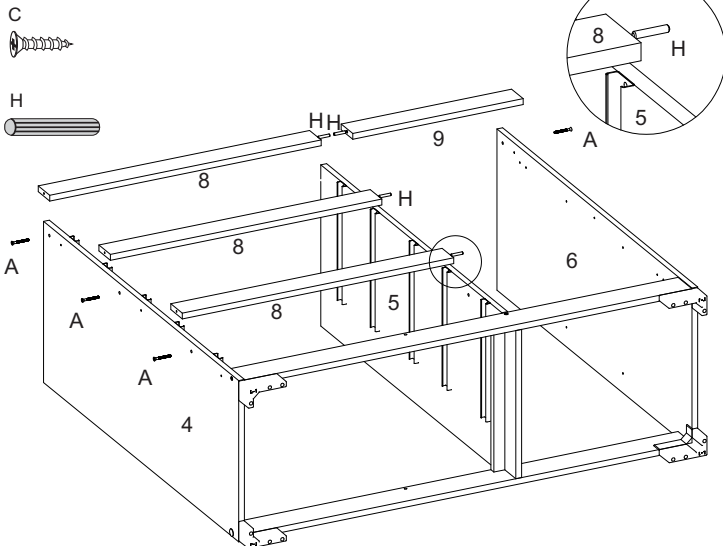

07° PASSO - Fixar acessórios (C+Q) nas peças 5,8 e 9

07° STEP - Fix accessories (C+Q) to parts 5,8 and 9

07° PASO - Fijar los accesorios (C+Q) a las piezas 5,8 y 9

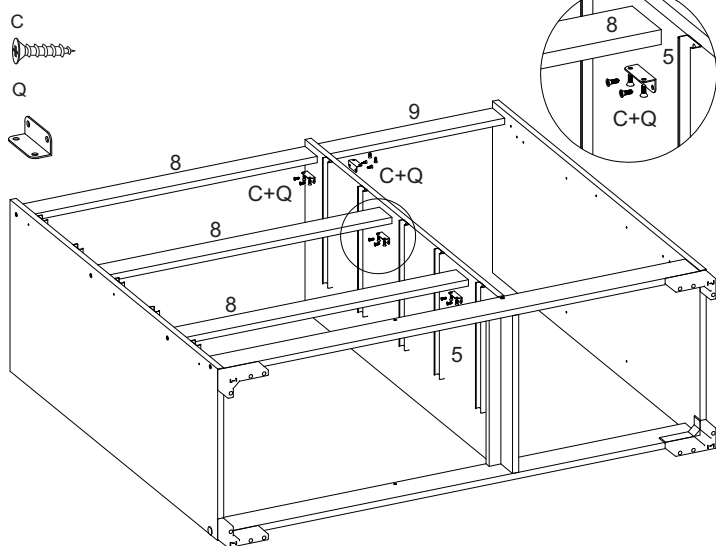

08° PASSO - Fixar peça 10 nas peças 4,5 e 6

08° STEP - Fix part 10 to parts 4,5 and 6

08° PASO - Fijar la pieza 10 a las piezas 4,5 y 6.

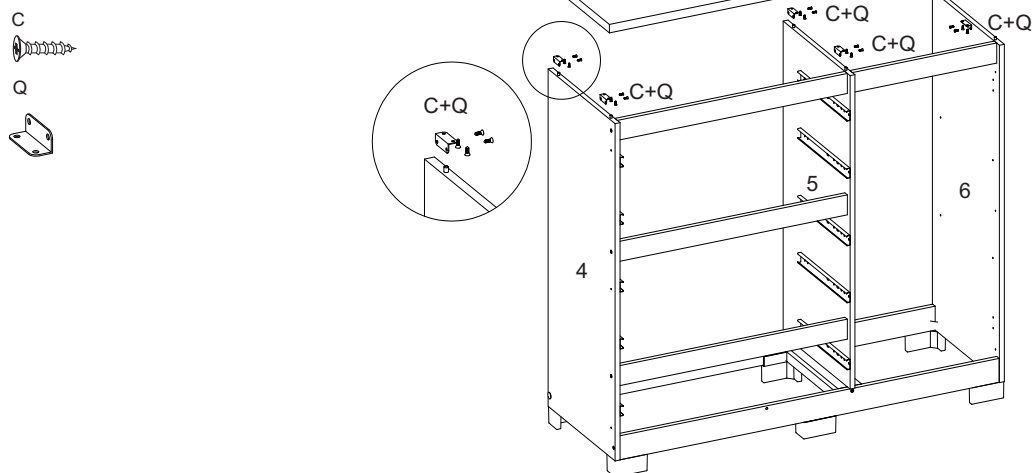

09° PASSO - Fixar peças 11 nas peças 4 e 6

09° STEP - Fix parts 11 to parts 4 and 6

09° PASO - Fijar las piezas 11 a las piezas 4 y 6.

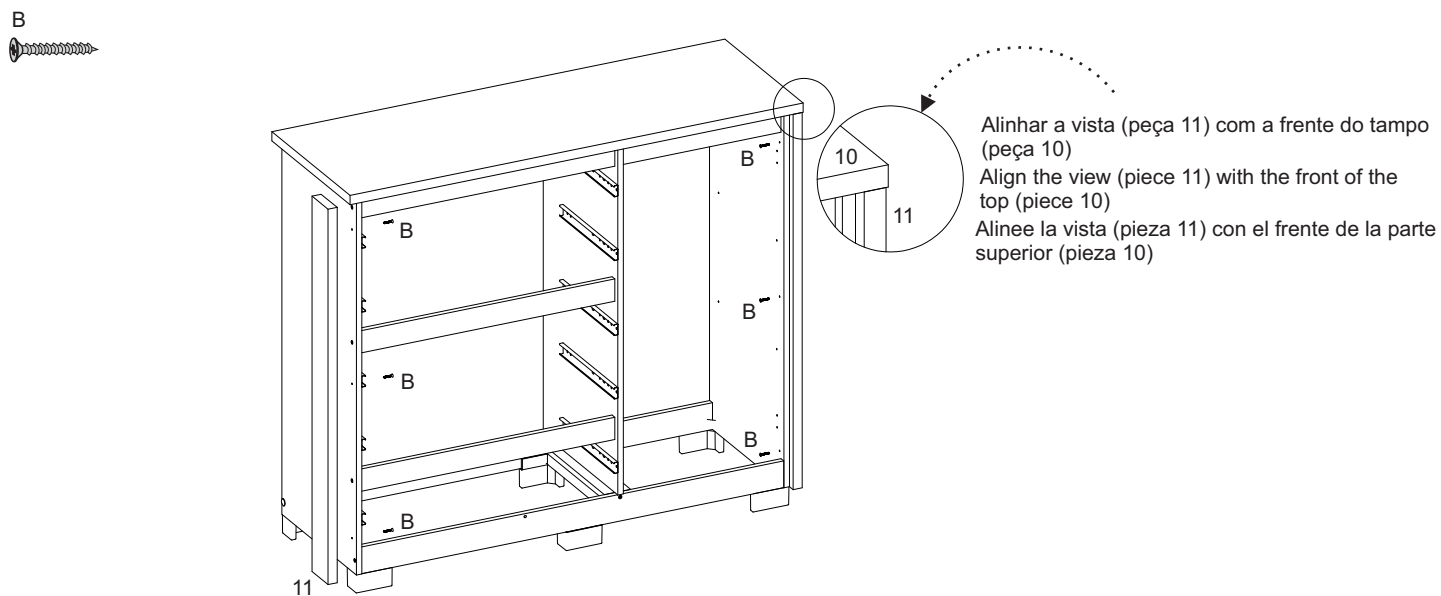

10° PASSO - Fixar peças 8 e 9 nas peça 4,5 e 6

10° STEP - Fix parts 8 and 9 to parts 4,5 and 6

10° PASO - Fijar las piezas 8 y 9 a las piezas 4,5 y 6.

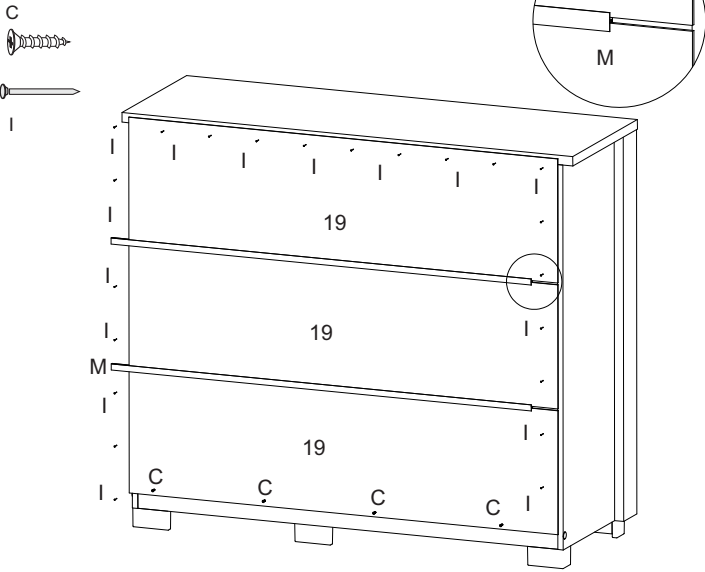

11° PASSO - Encaixar as peças 12 nas peças 5 e 6

11° STEP - Fit parts 12 into parts 5 and 6

11° PASO - Encaja las piezas 12 en las piezas 5 y 6.

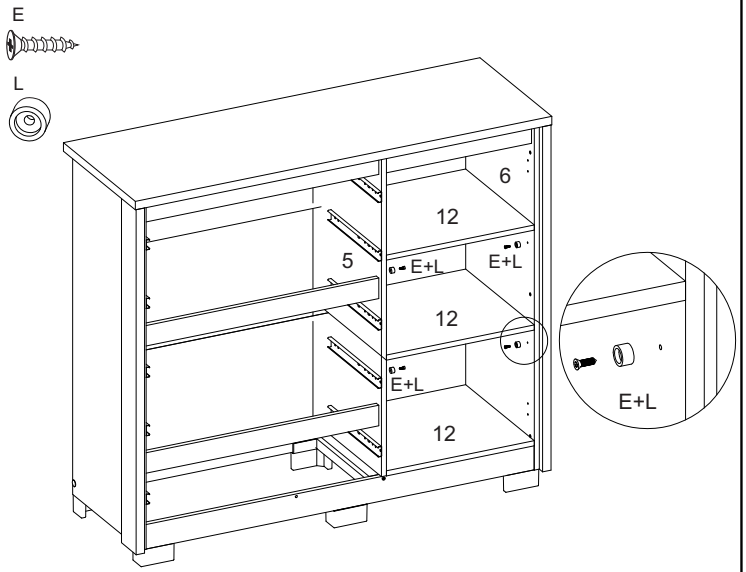

12° PASSO - Fixar peça 13 na peça 6

12° STEP - Fix part 13 to part 6

12° PASO - Fijar la pieza 13 a la pieza 6

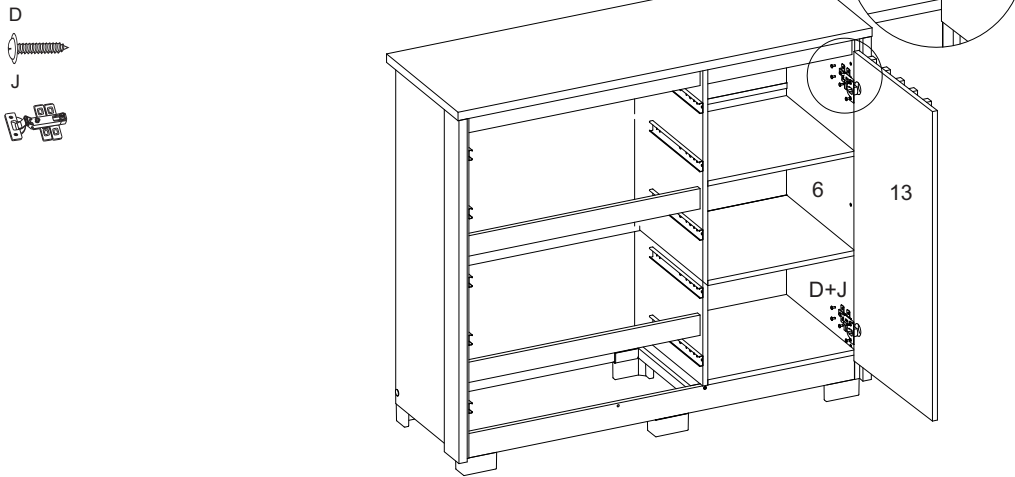

13° PASSO - Fixar peças 15 nas peças 14 e 16

13° STEP - Fix parts 15 to parts 14 and 16

13° PASO - Fijar las piezas 15 a las piezas 14 y 16.

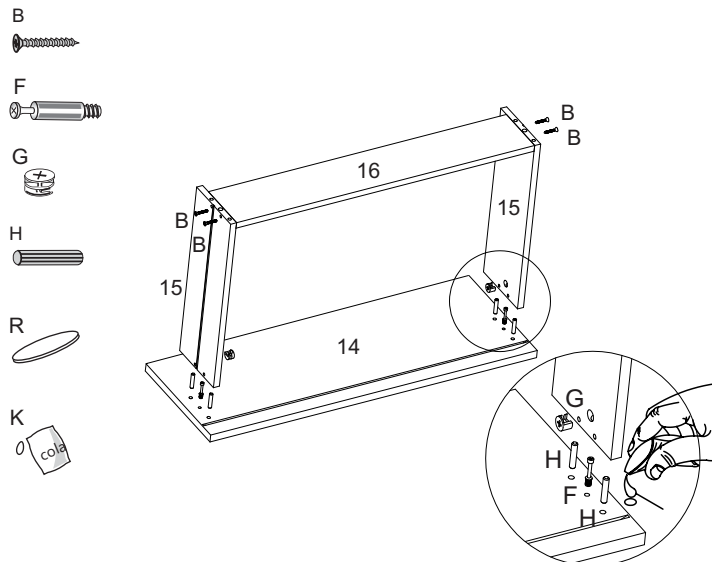

14° PASSO - Fixar peças 18 nas peças 14 e 16

14° STEP - Fix parts 18 to parts 14 and 16

14° PASO - Fijar las piezas 18 a las piezas 14 y 16.

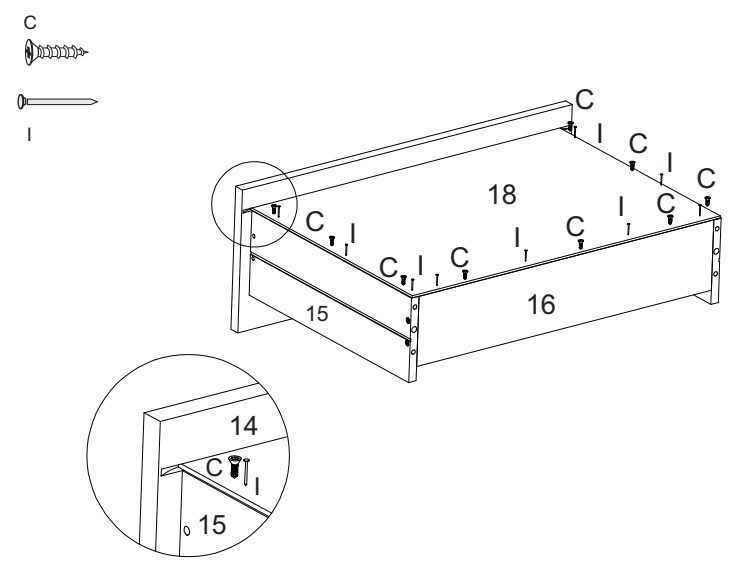

15° PASSO - Fixar peça 17 nas peças 14 e 16

15° STEP - Fix part 17 to parts 14 and 16

15° PASO - Fijar la parte 17 a las partes 14 y 16

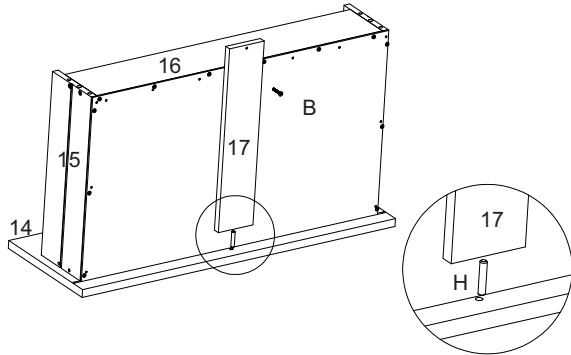
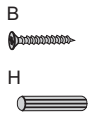

16° PASSO - Fixar acessório (C+P) nas peças 15

16° STEP - Fix accessory (C+P) to parts 15

16° PASO - Fijar el accesorio (C+P) a las piezas 15

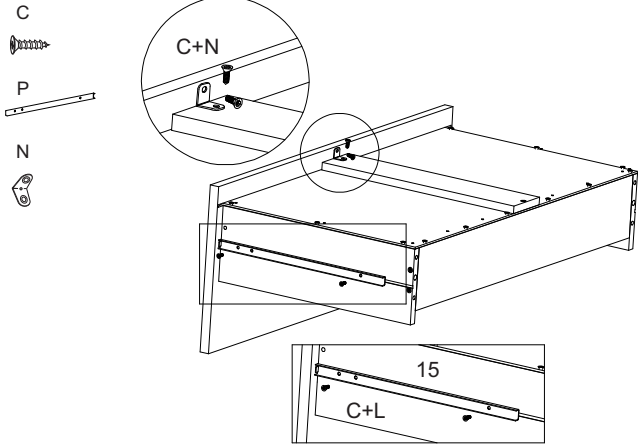

O produto contém um kit anti tombamento que deve ser fixado na parede e na parte traseira do produto
The product contains an anti-tip kit that must be fixed to the wall and back of the product
El producto contiene un kit antivuelco que debe fijarse a la pared y a la parte posterior del producto

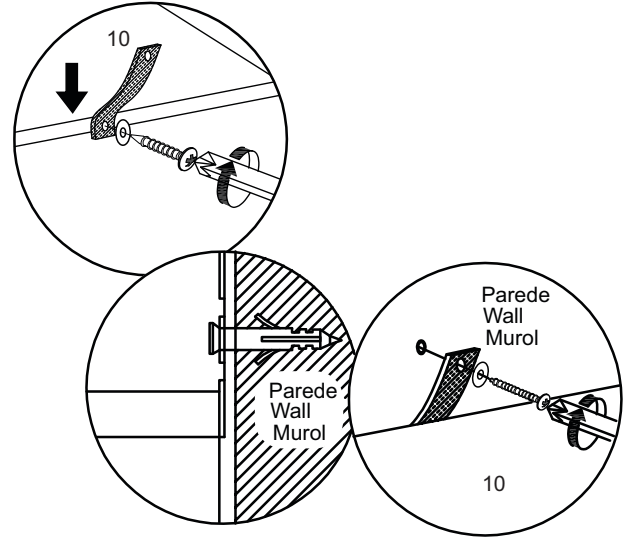
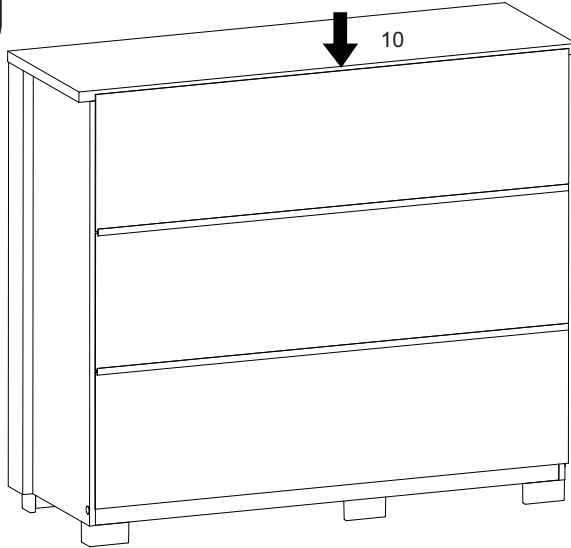
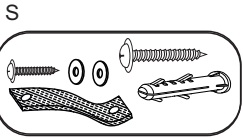

Aspecto final do produto

Final product aspect

Aspecto final del producto

