

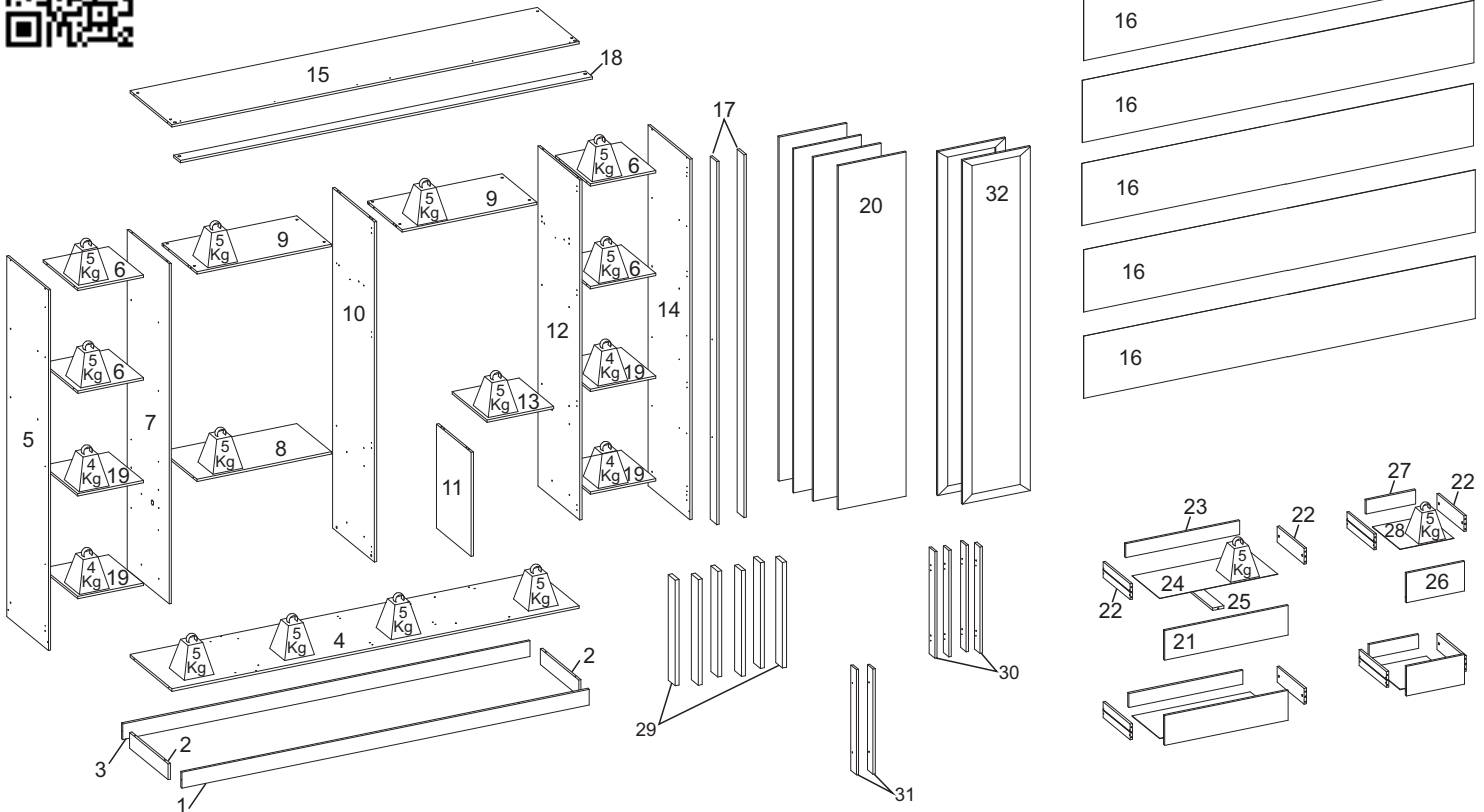

329 - GR NAPOLI



LISTA DE PEÇAS / PIECES LIST / LISTA DE PIEZAS

SEQ.	REF.	DESCRIÇÃO	DESCRIPTION	DESCRIPCIÓN	MAT.PRIMA	COMP.	LARG.	ESP.	QTD.
1	333128	Rodapé frontal	Front skirting board	frontal rodapé	MDP	2307	100	15	1
2	333129	Trava rodapé	Skirting clamp	Trava rodapé	MDP	437	100	15	2
3	333130	Rodapé traseiro	Rear skirting board	rodapé traseiro	MDP	2307	100	15	1
4	333131	Base	Base	Base	MDP	2307	480	15	1
5	333132	Lateral esquerda	Left side	Esquerda lateral	MDP	2235	480	15	1
6	333133	Prateleira	Prateleira	Prateleira	MDP	450	372	15	4
7	333134	Divisória esquerda	Left Divider	Divisória esquerda	MDP	2105	480	15	1
8	333135	Tampo gaveteiro maior	Tampo main drawer	Tampo dadoteiro mayor	MDP	759	450	15	1
9	333136	Base maleiro	maleiro base	base maleiro	MDP	759	450	15	2
10	333137	Divisória central	Central divider	Divisória central	MDP	2105	480	15	1
11	333138	Lateral gaveteiro	Drawer side	Giveteiro lateral	MDP	660	448	15	1
12	333139	Divisória direita	Direct division	Divisória direita	MDP	2105	480	15	1
13	333140	Tampo gaveteiro menor	Smaller drawer tampo	Tampo dadoteiro menor	MDP	450	432	15	1
14	333141	Lateral direita	Direct side	dirección lateral	MDP	2235	480	15	1
15	333142	Chapéu	Chapeu	Chapéu	MDP	2307	480	15	1
16	333143	Fundo	fund	fondo	HDF	2333	422	3	5
17	333144	Vista lateral	side view	vista lateral	MDP	2250	88	15	2
18	333145	Vista superior	Top view	vista superior	MDP	2337	88	15	1
19	333146	Prateleira móvel	Prateleira mobile	Prateleira móvel	MDP	450	372	15	4
20	333147	Porta	Holder	Puerta	MDP	2130	383	15	4
21	333148	Frente de gaveta maior	Main drawer front	Frente de Gaeta Mayor	MDP	687	188	15	2
22	333149	Lateral de gaveta	drawer side	Lateral de gaeta	MDP	350	100	15	8
23	333150	Contra fundo maior	Against major fund	Contra fondo mayor	MDP	624	88	15	2
24	333151	Fundo da gaveta maior	Bottom of the main drawer	Fundo da gaveta maior	HDF	652	355	3	2
25	333152	Apoio de gaveta	Drawer support	Apoio de Gaeta	MDP	350	72	15	2
26	333153	Frente de gaveta menor	Small drawer front	Frente de gaeta menor	MDP	375	188	15	2
27	333154	Contra fundo menor	Against minor property	contra fondo menor	MDP	320	88	15	2
28	333155	Fundo da gaveta menor	Bottom of the smaller drawer	Fundo da gaveta menor	HDF	355	348	3	2
29	333156	Distanciador de gaveta	Drawer spacer	Distanciador de gaveta	MDP	436	88	25	6
30	333157	Batente gaveta direito	Direct drawer flap	Batente gaveta direito	MDP	436	70	15	4
31	333158	Batente gaveta esquerdo	Left drawer panel	Batente Gaeta Esquerdo	MDP	436	70	15	2
32	703880	Porta com vidro reflecta	Porta with reflective glass	Porta con vidrio reflectante	MDF	2130	383	20	2

INSTRUÇÃO MONTAGEM PRODUTO

Intructions to Assembly / Instrucciones de montaje

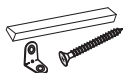

Separate the parts and accessories in an organized way
Separate parts and accessories in way organized
Separe las piezas y accesorios de manera organizada

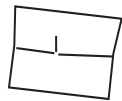

Cover the floor with the cardboard
Cover the floor with the cardboard
Cubra el suelo con la embalaje de cartón



It is necessary 02 people to assemble the product
02 people are required to assemble the product
Se requieren 02 persona para ensamblar el producto

The product must be assembled by a professional
The product must be assembled by a professional
El producto debe ser ensamblado por un profesional calificado

Tools necessary (not provided)

Not include tools / No herramientas



CUIDADO PARA CONSERVAÇÃO E LIMPEZA DO MÓVEL

Care to conservation and clean / Cuidados de limpeza

Maximum load weight refers to objects distributed evenly over the entire contact area of the part
Peso máximo de carga informado refere-se a objetos distribuído de maneira uniforme sobre toda área de contato da peça



The maximum load weight informed refers to objects distributed evenly over the entire contact area of the part
Conjunto de carga máxima de peso se refere a objetos distribuídos uniformemente sobre toda el área de contacto de la pieza de trabajo.



Do not wet the mobile and do not expose in a wet place
Do not wet the mobile and do not expose in a wet place
No moje el producto y no exponer en un lugar húmedo



Do not expose the mobile near heat sources
Do not expose the mobile near heat sources
no exponga cercano de fuentes de calor



Do not use abrasive products.
Do not use abrasive products.
No utilice productos abrasivos.



Clean with dry cloth
Clean with dry cloth
Limpieza con un paño limpio y seco



For cleaning the stamps on the pieces use a school eraser (item not provided)

Para limpiar los sellos de las piezas utilice un borrador escolar (artículo no incluido)

Para limpiar los sellos de las piezas utilice un borrador escolar (artículo no incluido)

LISTA DE ACESSÓRIOS E FERRAGENS / ACCESSORIES AND HARDWARE / ACCESORIOS Y HARDWARE

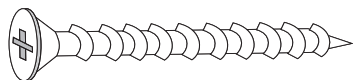

A- 700137 - Parafuso 4,5x45 (42x)
screw / tornillo



B- 700124 - Parafuso 3,5x25 (28x)
screw / tornillo



C- 700121 - Parafuso 3,5x12 (102x)
screw / tornillo



D- 700127 Parafuso 4,0x12 (144x)
screw / tornillo



E- 700130 - Parafuso 4,0x16 (16x)
screw / tornillo



F- 703921 - Parafuso 4,0x30 (48x)
screw / tornillo



G- 700146 - Parafuso minifix (24x)
Minifix screw /
Tornillo minifix



H- 700148
Tambor Minifix (24x)
Minifix Drum /
Tambor minifix



I- 700542 - Cavilha 6x30 (42x)
peg / cerrojo



J- 701333-Dobradiça curva
c/ pistão + calço (24x)
hinge / bisagra



K - 700113 - Corredixa (4x)
runners / corredera



L- 700446
Porca cilíndrica (8x)
Cylindrical Nut /
Tuerca cilíndrica



M - 700433-Suporte angular (2x)
Angled support / Soporte en ángulo



N-700438 - Suporte cabide (4X)
hook support / soporte gancho



O - 700441 - Suporte prateleira(16x)
Support/apoyo



P- 700157
Prego (164x)
nail / clavo

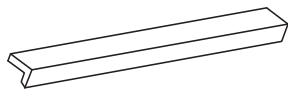

Q- 700179 - Puxador (6x)
Handle / Manija



R- 700464 - Kit com 8 Pés (1x)
Foot / Pie

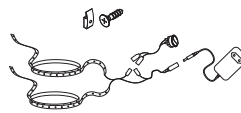

S - 703919 - Kit Led (1x)
Led Kit / Kit de Led



T- 702034
Cabideiro Alumínio (2x)
Coat Rack / Perchero



U- 700419 - Tapa furo minifix (58x)
minifix cover / tapa minifix



V- 703373 - Perfil H 2313 (3x)
Frame / Perfil



W- 703920 - Perfil H 1917 mm (1x)
Frame / Perfil



Y- 703918 - Perfil H 372 mm (1x)
Frame / Perfil



Z - 700516 - SACHE cola 20g (1x)
Glue / Goma

01° PASSO - Fixar peça 4 nas peças 1 e 3

01° STEP - Fix part 4 to parts 1 and 3

01° PASO - Fijar la parte 4 a las partes 1 y 3

A



L

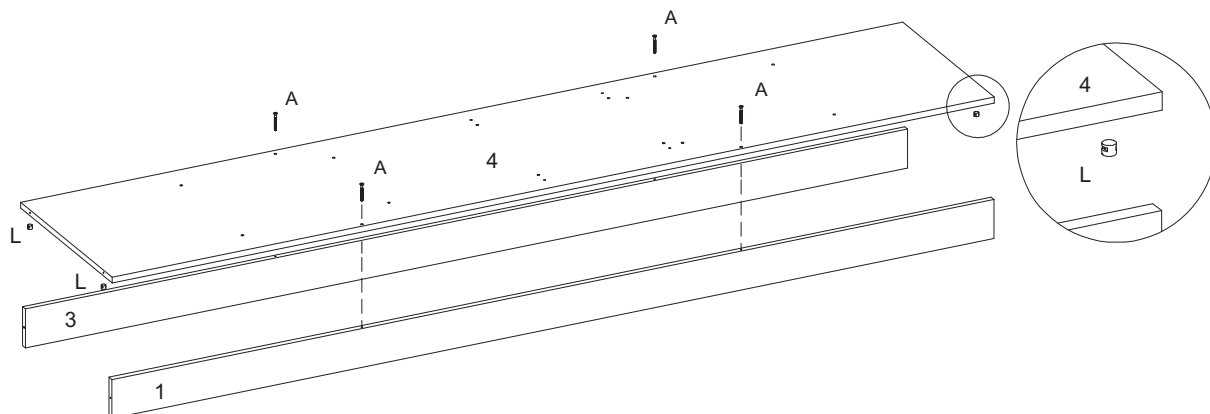

02° PASSO - Fixar peças 2 nas peça 4

02° STEP - Fix parts 2 to part 4

02° PASO - Fijar las partes 2 a las parte 4

A

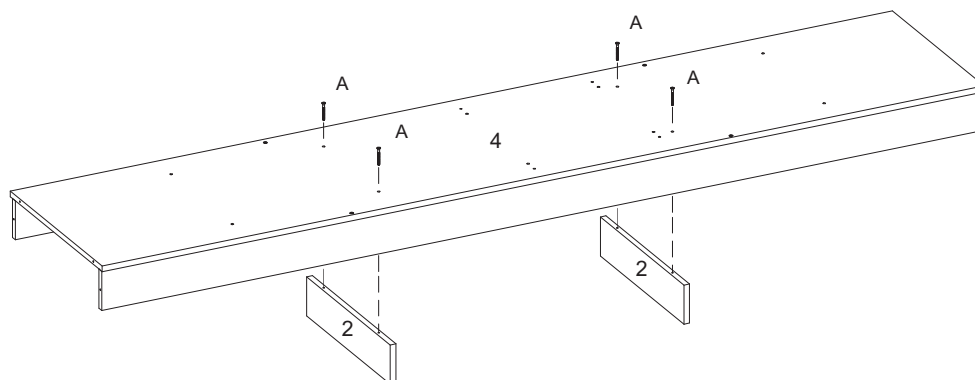

03° PASSO - Fixar os pés nas peças 1,2 e 3

03° STEP - Fix the feet to parts 1,2 and 3

03° PASO - Fijar los pies a las partes 1,2 y 3

R

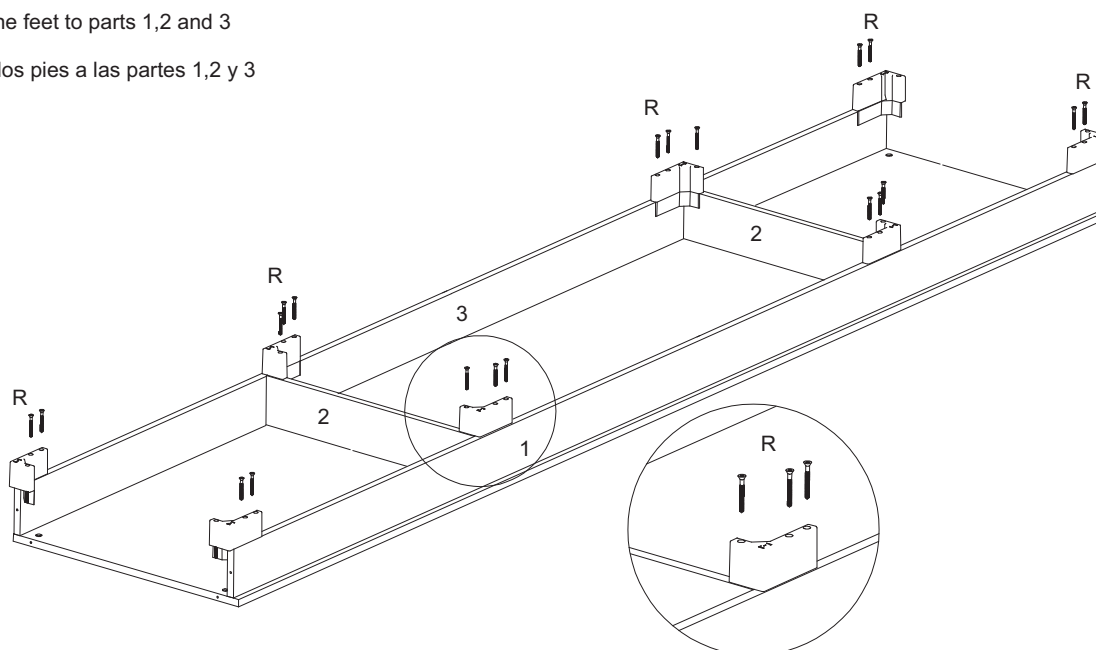

04° PASSO - Fixar peças 5 e 7 nas peças 1,3,4 e 6

04° STEP - Fix parts 5 and 7 to parts 1,3,4 and 6

04° PASO - Fijar las partes 5 y 7 a las partes 1,3,4 y 6

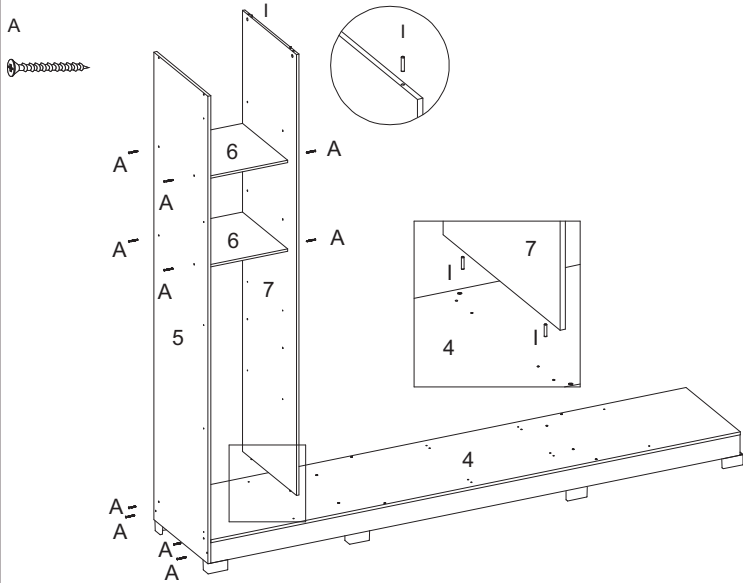

05° PASSO - Fixar peça 10 na peça 4. Fixar peças 8 e 9 na peças 7 e 10

05° STEP - Fix part 10 to part 4. Fix parts 8 and 9 to parts 7 and 10

05° PASO - Fijar la parte 10 a la parte 4. Encajar las partes 8 y 9 en las partes 7 y 10

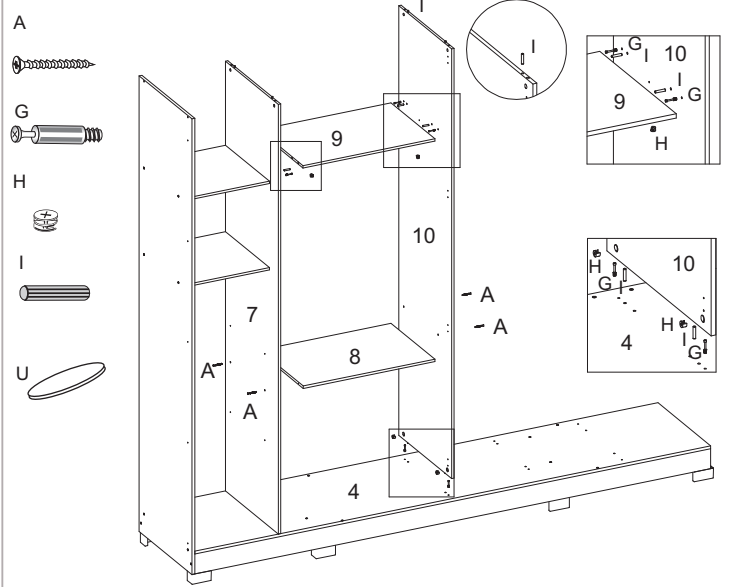

06° PASSO - Fixar a peça 11 e 12 na peça 4. Fixar peças 9 e 13 nas peças 10,11 e 12

06° STEP - Fix parts 11 and 12 to part 4. Attach parts 9 and 13 to parts 10,11 and 12.

06° PASO - Fijar las partes 11 y 12 a la parte 4. Fijar las partes 9 y 13 a las partes 10,11 y 12.

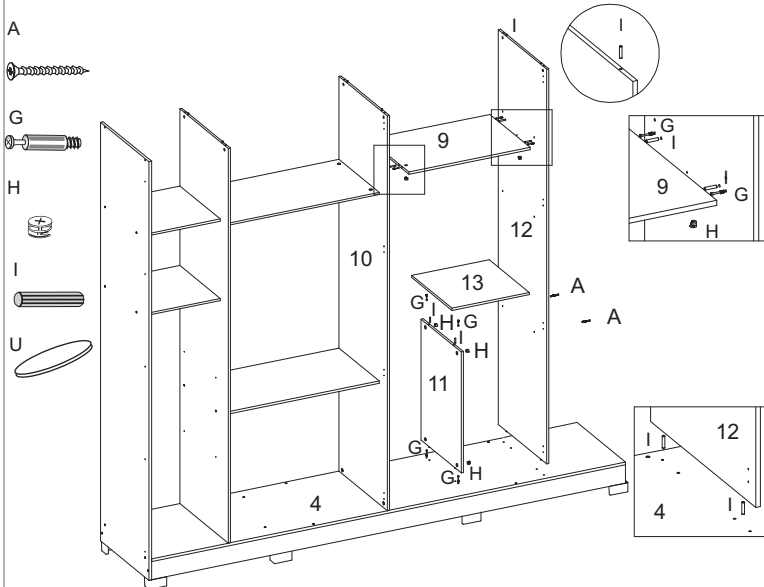

07° PASSO - Fixar peça 14 nas peças 1,3 e 4. Fixar peças 6 nas peças 12 e 14

07° STEP - Fix part 14 to parts 1,3 and 4. Fix part 6 to parts 12 and 14

07° PASO - Fije la parte 14 a las partes 1, 3 y 4. Fije la parte 6 a las partes 12 y 14

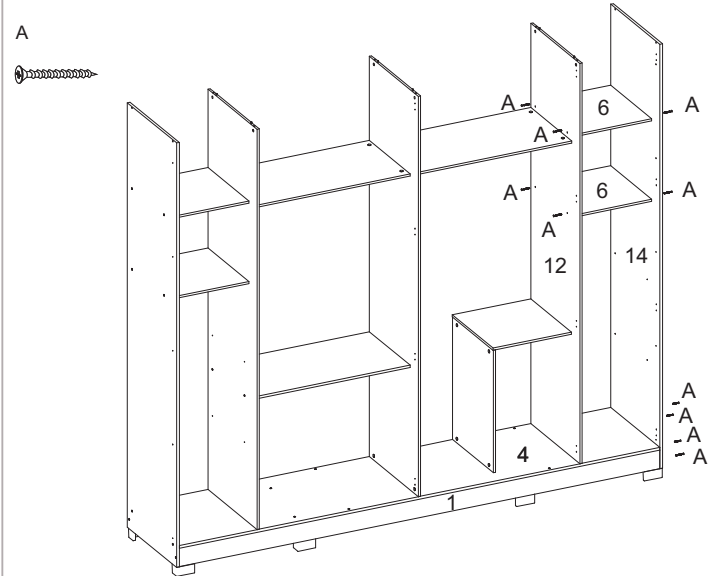

08° PASSO - Fixar a peça 15 nas peças 5, 7, 10, 12 e 14.

08° STEP - Fix part 15 to parts 5, 7, 10, 12 and 14.

08° PASO - Fijar la pieza 15 a las piezas 5, 7, 10, 12 y 14.

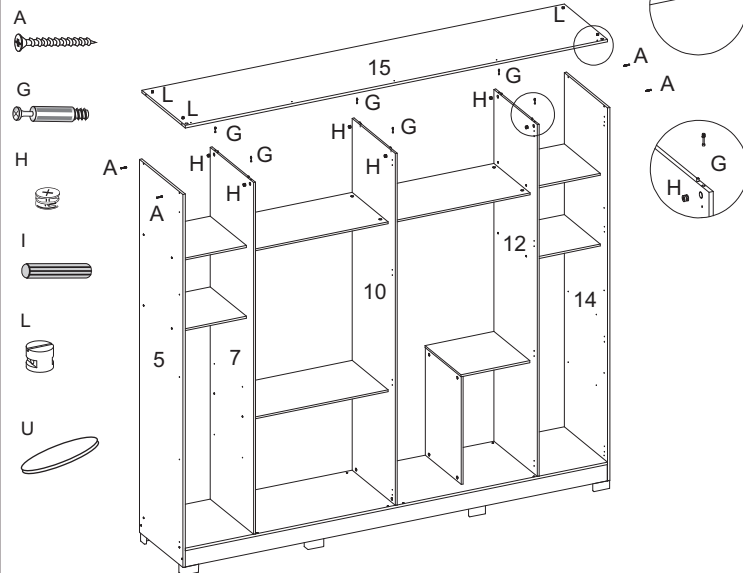

09° PASSO - Fixar peças 16 na parte de trás do produto

09° STEP - Fix parts 16 to the back of the product

09° PASO - Fijar las piezas 16 en la parte trasera del producto

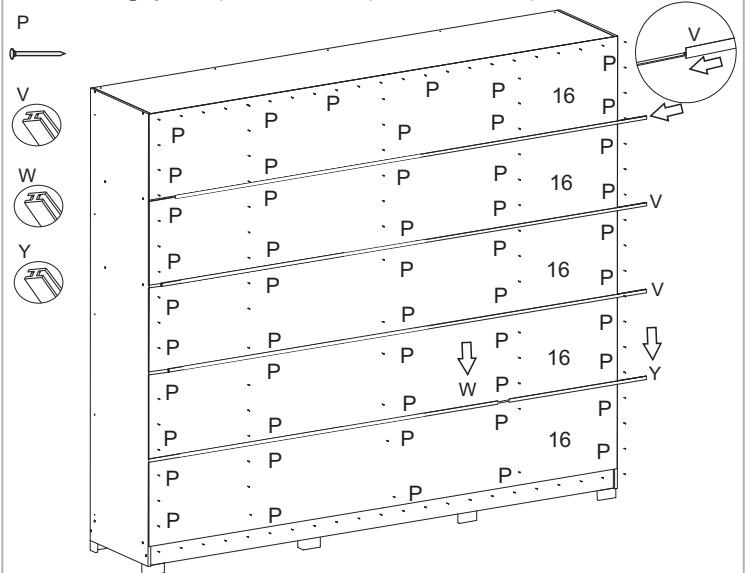

10º PASSO - Fixar peças 17 e 18 nas peças 5,14 e 15

10º STEP - Fix parts 17 and 18 to parts 5,14 and 15

10º PASO - Fijar las partes 17 y 18 a las partes 5,14 y 15

B

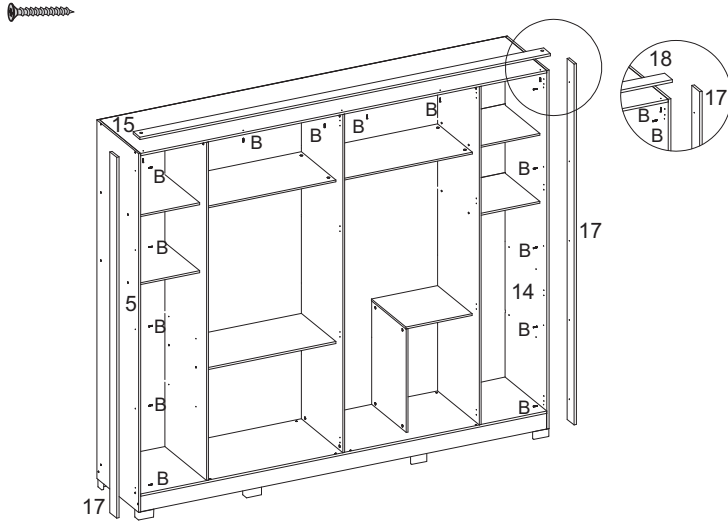

11º PASSO - Fixar os suportes no produto

11º STEP - Fix the brackets to the product

11º PASO - Fijar de los soportes en el producto

C

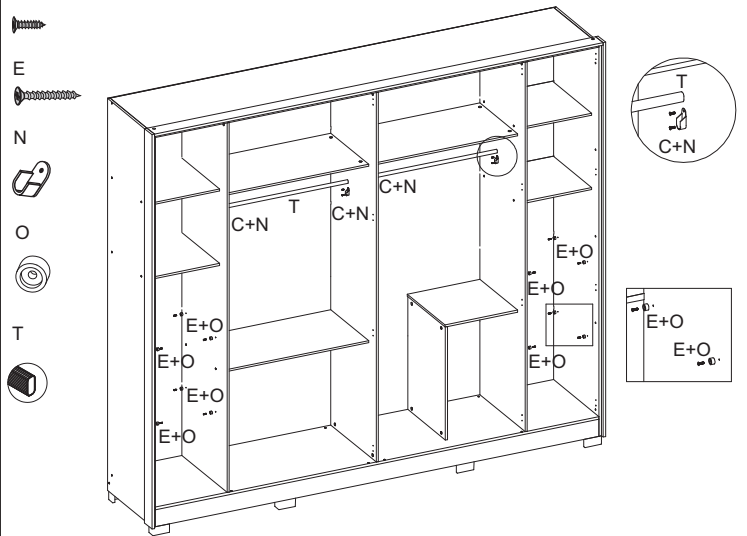

12º PASSO - Fazer a separação das corredeira

12º STEP - Separate the slides

12º PASO - Separar las diapositivas

K

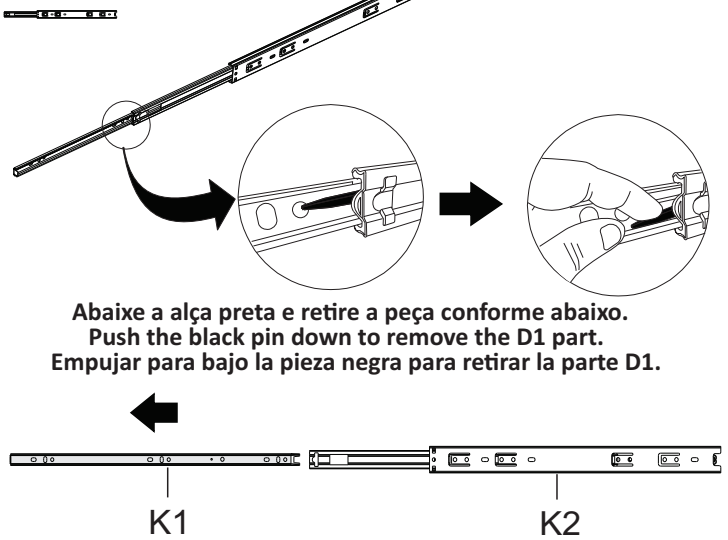

13º PASSO - Fixar os acessórios C+K2 nas peça 11

13º STEP - Fix the C+K2 accessories to part 11.

13º PASO - Fijar los accesorios C+K2 en la pieza 11.

C

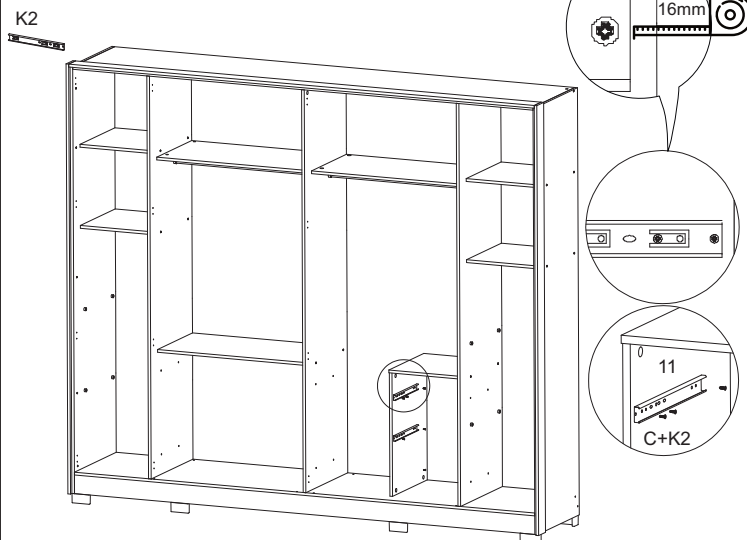

14º PASSO - Fixar peças 31 nas peças 29

14º STEP - Fix parts 31 to parts 29.

14º PASO - Fijar las piezas 31 a las piezas 29.

F

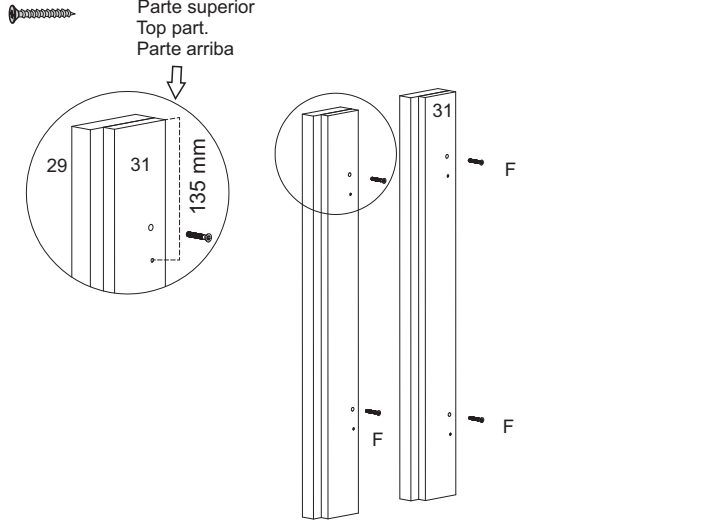

15º PASSO - Fixar peças 30 nas peças 29

15º STEP - Fix parts 30 to parts 29.

15º PASO - Fijar las piezas 30 a las piezas 29.

F

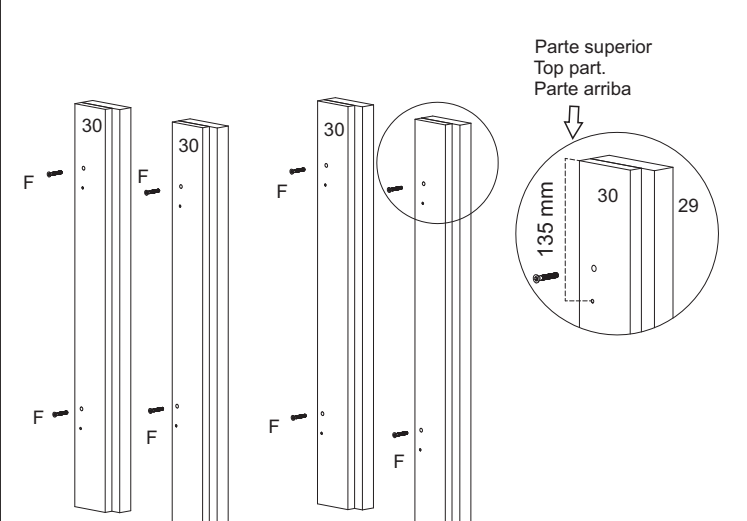

16° PASSO - Fixar os acessórios C+K2 nas peças 30 e 31

16° STEP - Fix the C+K2 fittings to parts 30 and 31.

16° PASO - Fijar los accesorios C+K2 a las piezas 30 y 31.

C

K2

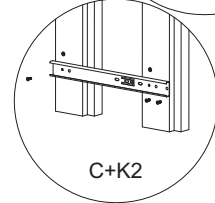
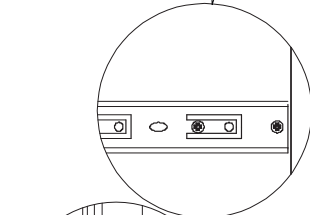
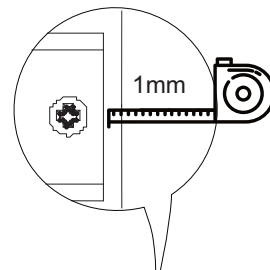
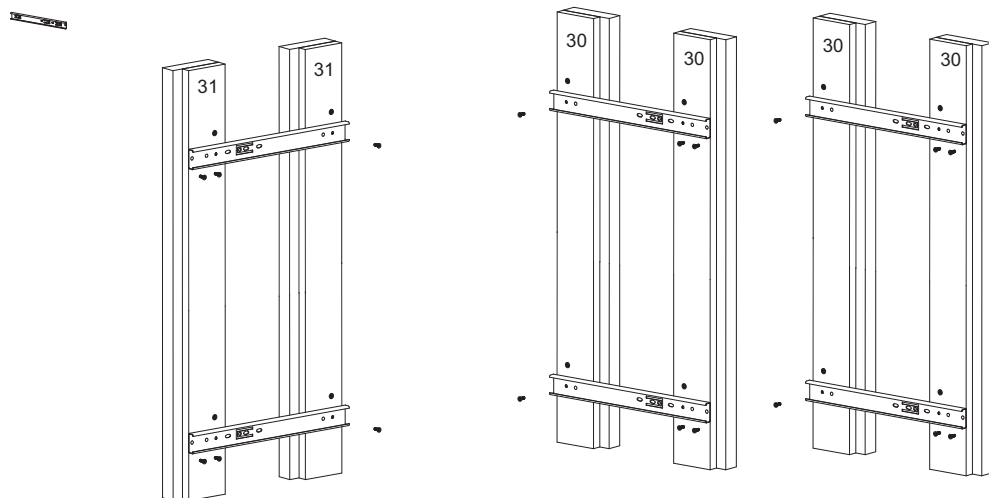

17° PASSO - Fixar as peças 29 nas peças 7, 10 e 12

17° STEP - Fix parts 29 to parts 7, 10, and 12.

17° PASO - Fijar las piezas 29 a las piezas 7, 10 y 12.

F

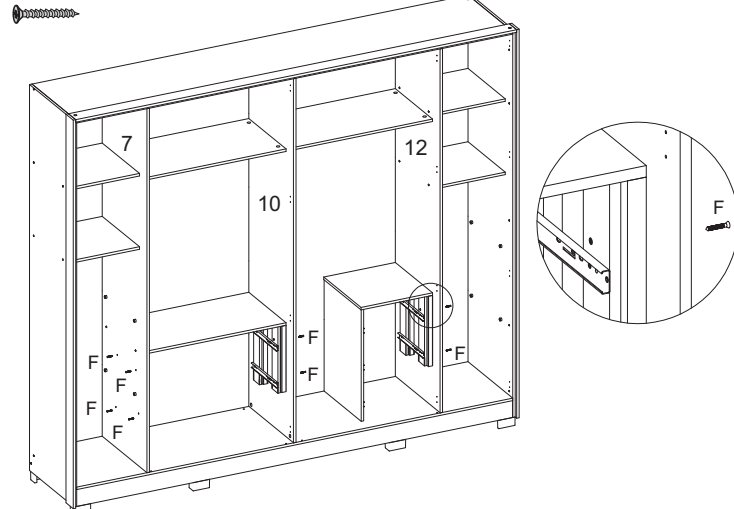

18° PASSO - Fixar peças 22 nas peças 21 e 23

18° STEP - Fix parts 22 to parts 21 and 23.

18° PASO - Fijar las piezas 22 a las piezas 21 y 23.

F

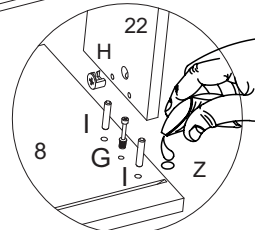
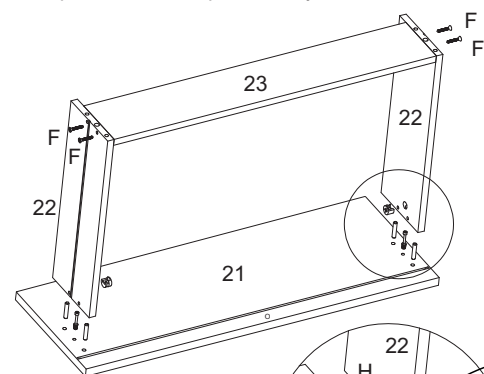

19° PASSO - Fixar peça 24 nas peças 22 e 23

19° STEP - Fix part 24 to parts 22 and 23.

19° PASO - Fijar la pieza 24 a las piezas 22 y 23.

C



P

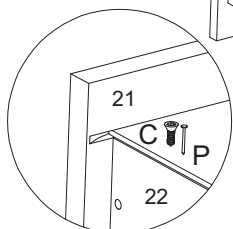
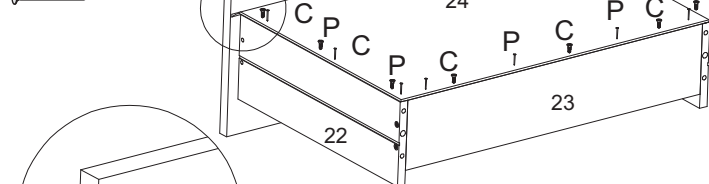

20° PASSO - Fixar peça 25 na peça 23

20° STEP - Fix part 25 to part 23.

20° PASO - Fijar la pieza 25 a la pieza 23.

F



I

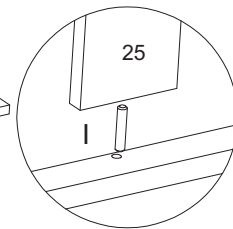
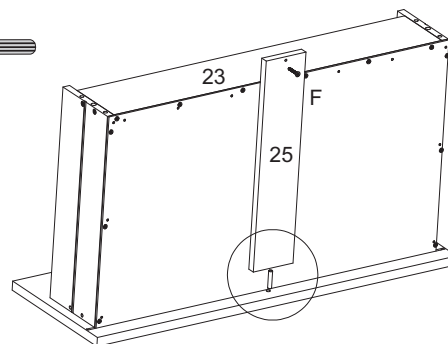

21° PASSO - Fixar acessório (C+K1) na peças 22 e (C+M) nas peças 21 e 25

21° STEP - Fix accessory (C+K1) to part 22 and (C + M) to parts 21 and 25

21° PASO - Fijar el accesorio (C+K1) a la pieza 22 y (C + M) a las piezas 21 y 25

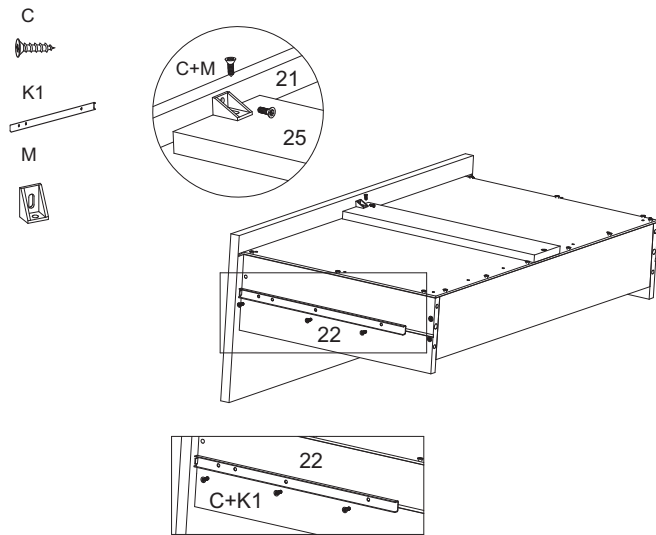

22° PASSO - Fixar peças 22 nas peças 26 e 27

22° STEP - Fix parts 22 to parts 26 and 27.

22° PASO - Fijar las piezas 22 a las piezas 26 y 27.

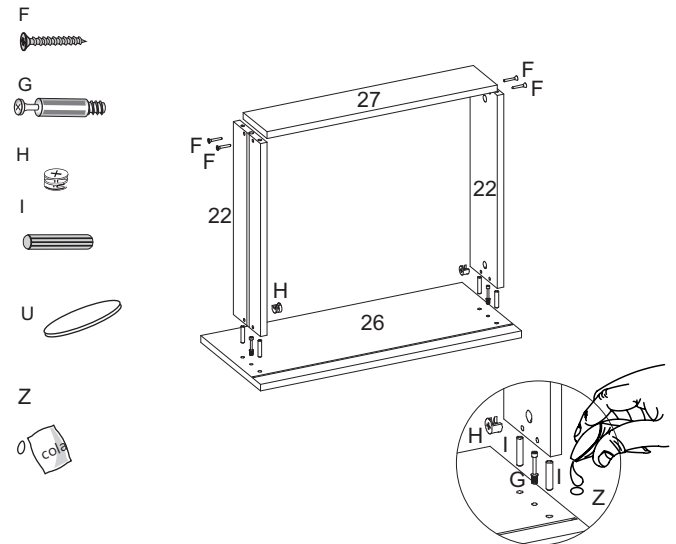

23° PASSO - Fixar as peças 29 nas peças 7, 10 e 12

23° STEP - Fix parts 29 to parts 7, 10, and 12.

23° PASO - Fijar las piezas 29 a las piezas 7, 10 y 12.

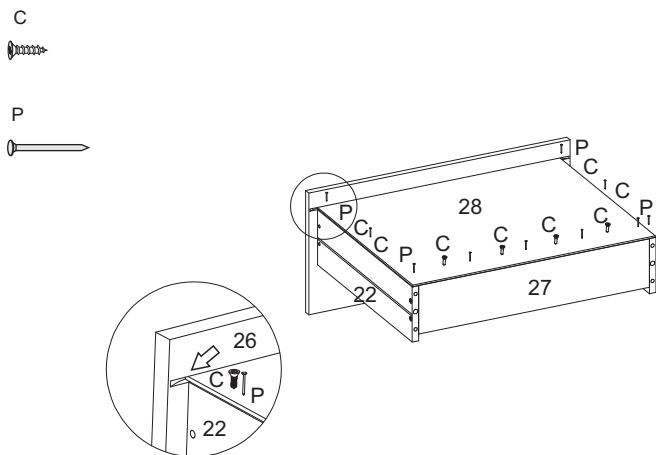

24° PASSO - Fixar acessórios C+K1 nas peças 22

24° STEP - Fix los accesorios C+K1 a las piezas 22

24° PASO - Fijar C+K1 accessories to parts 22

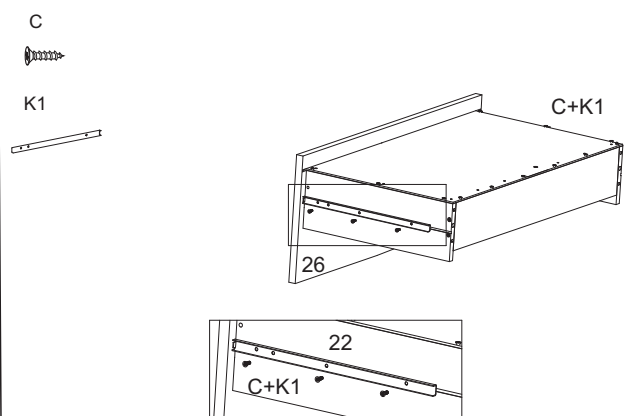

25° PASSO - Fixar acessórios D+J nas peças 20 e 32

25° STEP - Fix D+J accessories in parts 20 and 32

25° PASO - Fijar accesorios D+J en piezas 20 y 32

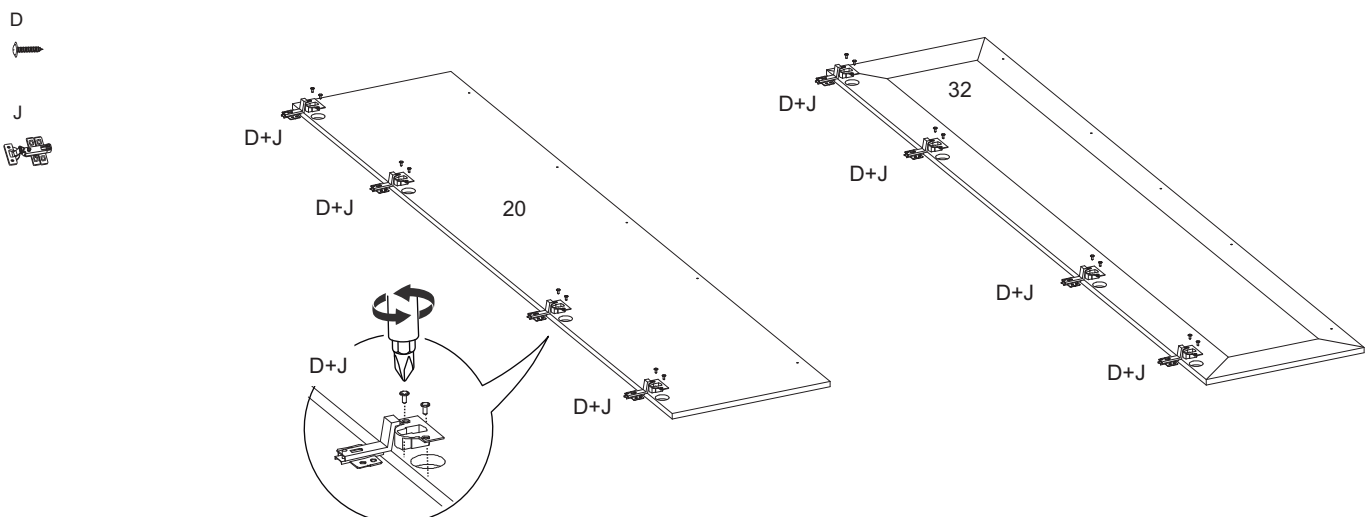

26° PASSO - Passe a fita led pelo furo do chapéu e vista superior e cole nas laterais.

26° STEP - Pass the LED strip through the hole in the top and stick it to the side.

26° PASO - Pasa la tira de LED por el agujero de parte superior y pégala a los lateral.

S

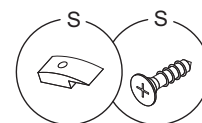
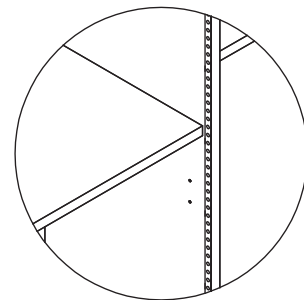
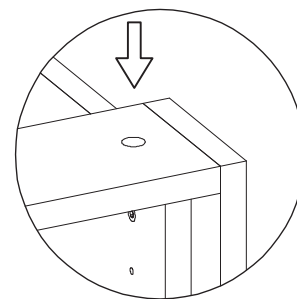
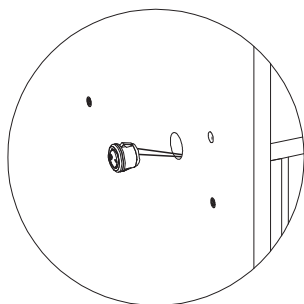
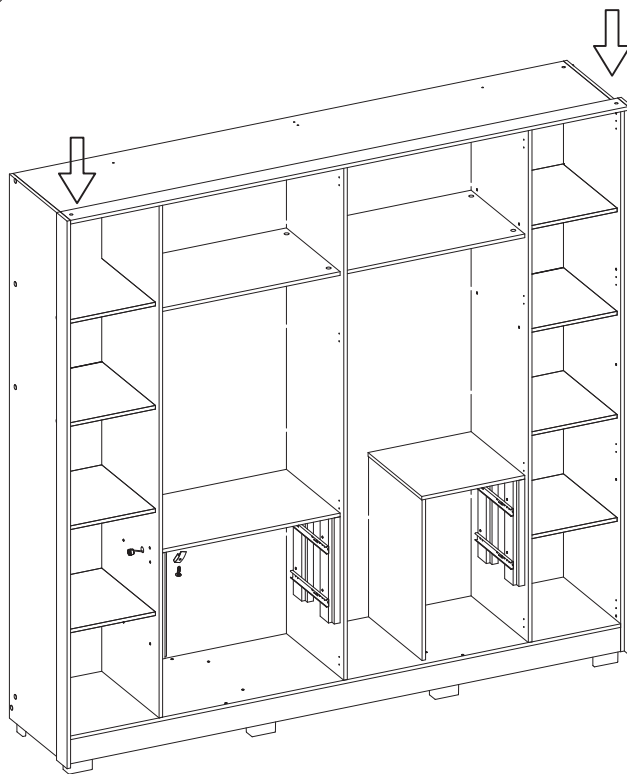
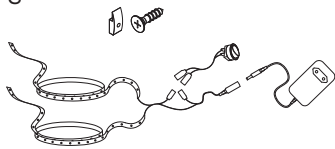

Utilize o acessório acima para fixar/organizar a fiação do LED.

Use the accessory above to fix/organize the LED wiring.

Utilice el accesorio anterior para fijar/organizar el cableado del LED.

Passar o fio do botão do led entre os perfil H.

Pass the LED button wire between the H-profiles.

Pase el cable del botón LED entre los perfiles en H.

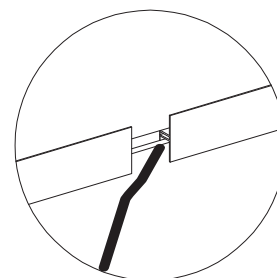
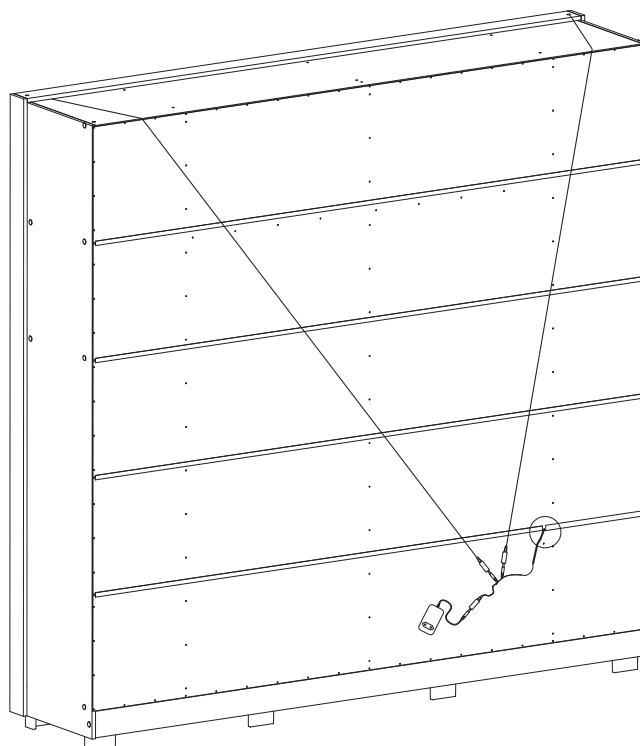

27° PASSO - Encaixar as gavetas

27° STEP - Fit the drawers

27° PASO - Encajar los cajones juntos

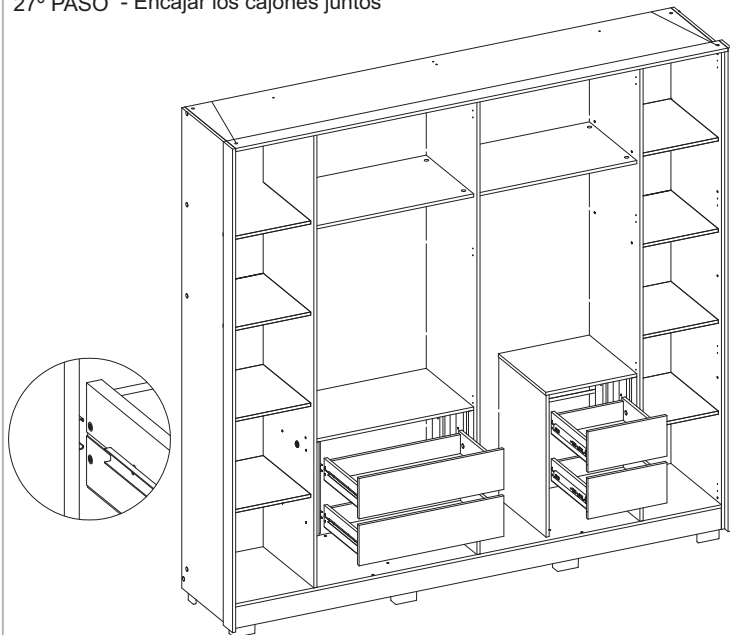

28° PASSO - Fixar peças 20 e 32 no produto

28° STEP - Fix parts 20 and 32 to the product.

28° PASO - Fijar las piezas 20 y 32 al producto.

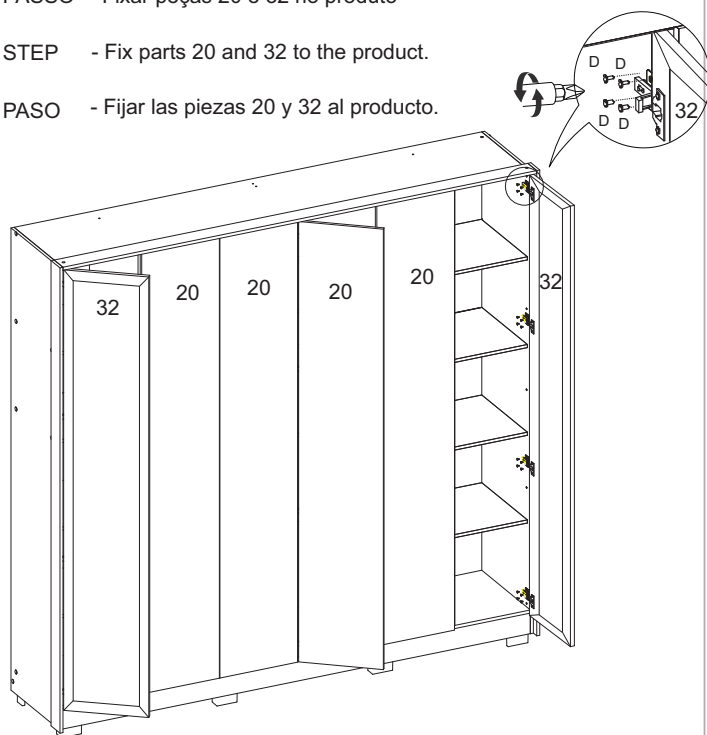

29° PASSO - Fixar os acessórios B+Q nas peças 20

29° STEP - Fix the B+Q accessories to parts 20.

29° PASO - Fijar los accesorios B+Q a las piezas 20.

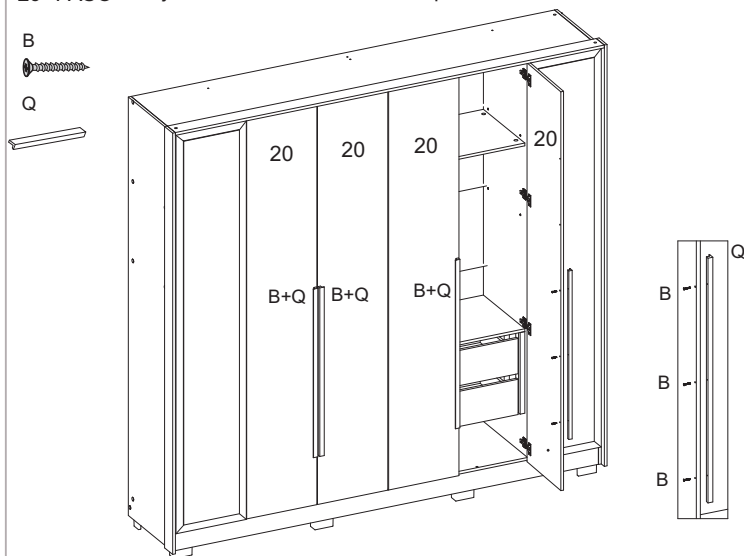

30° PASSO - Fixar os acessórios F+Q nas peças 32

30° STEP - Fix the F+Q accessories to parts 32.

30° PASO - Fijar los accesorios F+Q a las piezas 32.

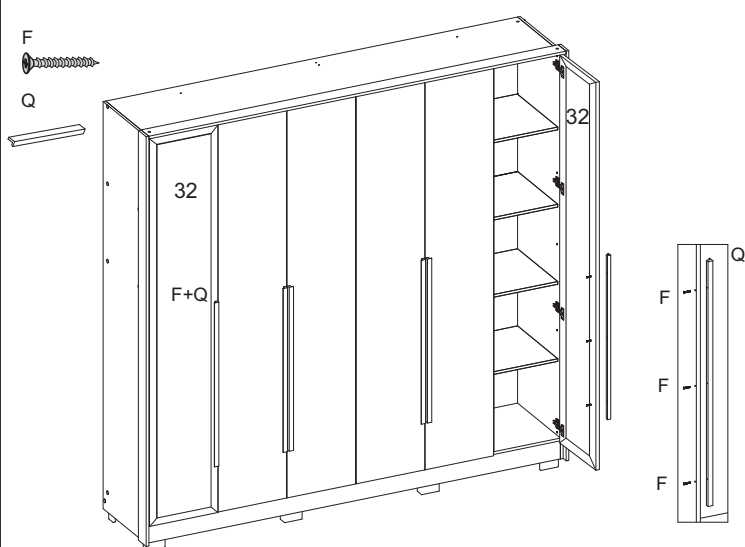

Aspecto final do produto

Final product aspect

Aspecto final del producto

