

# MANUAL DE MONTAGEM

ASSEMBLY INSTRUCTIONS

INSTRUCCIONES DE MONTAJE

NOTICE DE MONTAGE



1600mm

COD: 1031500

COD: 1018400

COD: 1018700

1800mm

COD: 1021300

COD: 1021400

COD: 1031600

# OBSERVAÇÕES IMPORTANTES IMPORTANT REMARKS OBSERVACIONES IMPORTANTES REMARQUES IMPORTANTES



Nunca escale ou se apoie sobre o móvel. Você pode sofrer graves acidentes.

Never climb or lean on the furniture. You may suffer serious accidents.

Nunca escale o apoye sobre el mobiliario. Usted puede sufrir accidentes graves.

Ne montez jamais sur le meuble. Vous pourriez subir un grave accident.



Movimente o móvel com cuidado, sem arrastar. Peça ajuda a outra pessoa para fazê-lo.

Move the piece carefully, don't drag it. Ask for someone else's help to do so.

Mover la unidad con cuidado, sin arrastar. Pedir ayuda da otra persona para moverlo.

Déplacez les meubles avec précaution sans le faire glisser. Demandez a quelqu'un de vous aider à le faire.



Limpe com um pano limpo e umedecido em água e sabão neutro. Não utilizar produtos químicos e abrasivos.

Wipe clean using a damp cloth and a mild cleaner. Don't use abrasive and chemical products.

Limpie con un paño limpiohumedecido con agua y jabón neutro. No utilice productos químicos y abrasivos.

Nettoyez avec un chiffon propre imbibé avec d'eau et de savon doux. N'utilisez pas de produits chimiques et abrasifs.

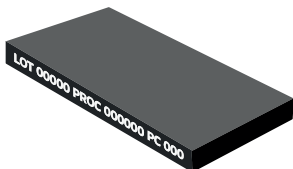

Observe os números impressos nas bordas para identificar as peças.

Identify the parts by observing the number printed on their edges.

Identifique las piezas observando el numero impresso en sus bordes.

Notez les numéros imprimés sur les bords pour identifier les pièces.

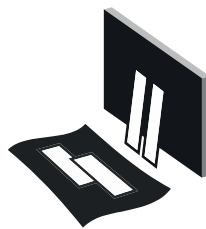

Utilize a embalagem para forrar a área de montagem e separar todas as peças.

Use the packaging to cover the assembly area and separate all parts.

Utilice el embalaje para cubrir la area de montaje y separe las piezas.

Couvrez la zone d'assemblage avec l'emballage pour séparer le pièces.



Não colocar objetos em alta temperatura diretamente sobre superfícies de vidro.

Do not place high-temperature objects directly on glass surfaces.

No coloque objetos de alta temperatura directamente sobre superficies de vidro.

Ne placez pas d'objets à haute température directment sur les surfaces en verre.

# ACESSÓRIOS HARDWARE HERRAJES ACCESSOIRES

Identifique e separe os acessórios utilizados. Em cada embalagem, uma etiqueta identifica as peças e onde utilizá-las.

Identify and separate the hardware used in the assembly. There's a label on each package identifying the parts and where to use them.

Identifique y separe los accesorios utilizados en el montaje. Observe la etiqueta en cada paquete para saber donde montar.

Identifiez et séparez les accessoires à être utilisés. Dans chaque emballage il y a une étiquette pour identifier les pièces et où les utiliser.

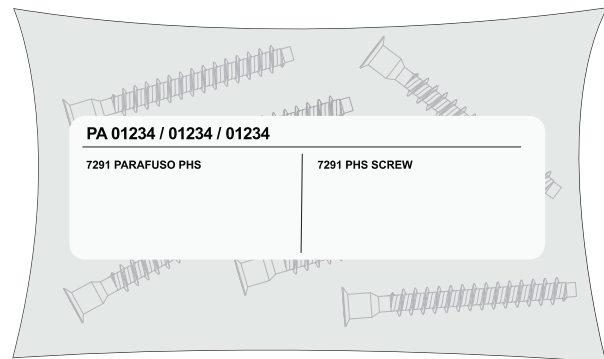







## PA1031500 / 1018400 / 1018700

L:1600mm A:780mm P:895mm  
W:62.99in H:30.70in D:35.23in  
L:1600mm A:780mm P:895mm  
L:1600mm H:780mm P:895mm

## PA1021300/ 1021400 / 1031600

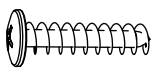
L:1800mm A:780mm P:895mm  
W:70.86in H:30.70in D:35.23in  
L:1800mm A:780mm P:895mm  
L:1800mm H:780mm P:895mm

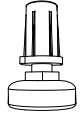

<p><b>A</b> COD. 11698 <b>M6 x 180</b> (01X)</p> 	<p><b>B</b> COD. 4936 <b>6.0 x 45</b> (08X)</p> 	<p><b>C</b> COD. 9176 (02X)</p> 	<p><b>D</b> COD. 11701 <b>6.0 x 30</b> (16X)</p> 	<p><b>E</b> COD. 9267 (01X)</p> 
<p><b>F</b> SAPATA PLASTIC STOPPER ALMOHADILLA PLASTICO BOUCHON PLASTIQUE (04X)</p> 	<p><b>G</b> COD. 9509 (01X)</p> 	<p><b>H</b> COD. 0329 <b>8.0 x 30</b> (16X)</p> 		

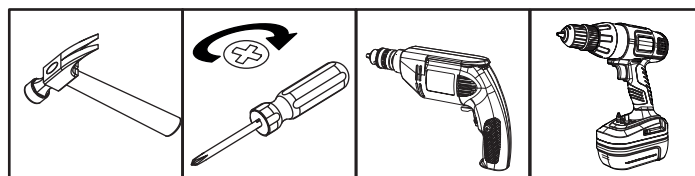

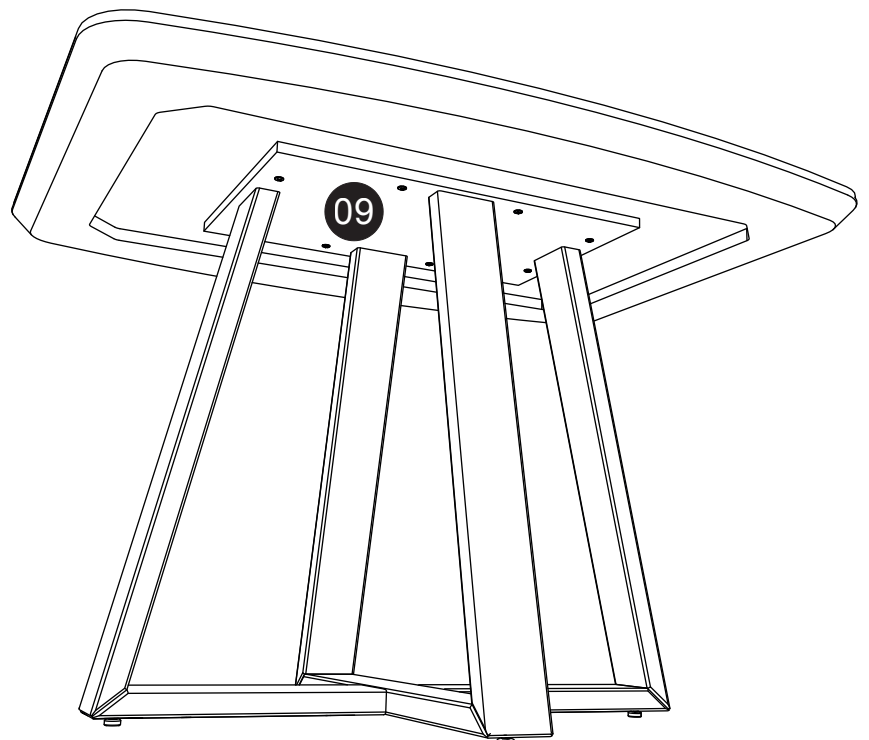
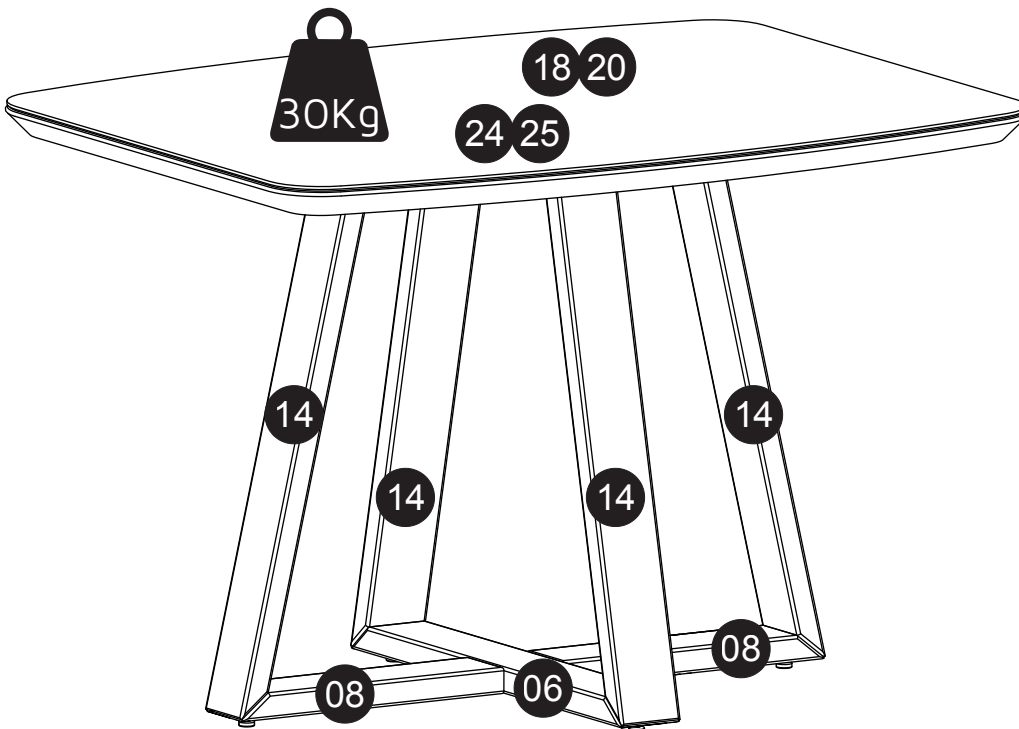

DESCRIÇÃO/ DESCRIPTION/ DESCRIPCIÓN/ DESCRIPTION

1600mm / 1800mm						
PEÇA PART PIEZA PIÈCE STÜCK	QUANTIDADE QUANTITY CANTIDAD QUANTITÉ MENGE	DESCRIÇÃO	DESCRIPTION	DESCRIPCIÓN	DESCRIPTION	CAIXA BOX CAJA BOÎTE BOX
06	01	BASE CENTRAL	CENTER BASE	BASE CENTRAL	BASE CENTRALE	02
08	02	TRAVESSA MENOR	SHORT CROSSPIECE	TRAVESAÑO MENOR	TRAVERSE PLUS PETITE	02
09	01	SUB-TAMPO	LOWER COVER	CUBIERTA INFERIOR	DESSUS	02
14	04	TRAVESSA LATERAL	SIDE CROSSPIECE	TRAVESAÑO LATERAL	TRAVERSE LATÉRALE	02
18/20	01	TAMPO 1.6	TOP PANEL	PANEL SUPERIOR	PLATEU	01
24/25	01	TAMPO 1.8	TOP PANEL	PANEL SUPERIOR	PLATEU	01



30Kg = 66Lb

01

<b>F</b> 	<b>G</b> 	<b>H</b> COD. 0329 
---	---	--

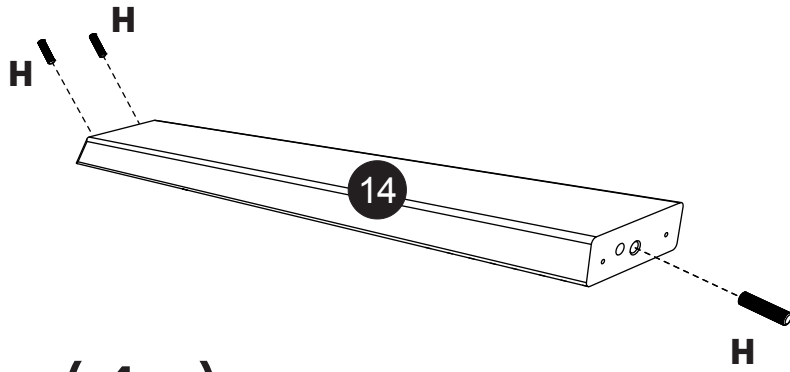
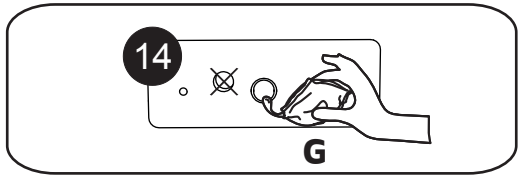
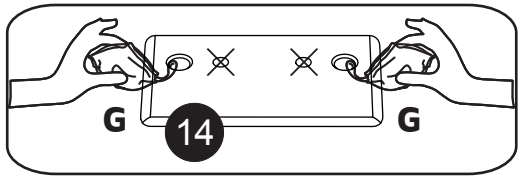

(4x)

PASSO 01  
Aplicar cola nos furos indicados e encaixar cavilhas 3x**0329** nas travessa **14**.

STEP 01  
Apply glue as indicated and insert dowels 3x**0329** on the crosspiece **14**.

PASO 01  
Aplicar pegamento en las perforaciones indicadas y clavijas de ajuste 3x**0329** en el travesaño **14**.

ÉTAPE 01  
Appliquez la colle sur les trous indiqués et insérez les chevilles 3x**0329** et entrejambe **14**.

02

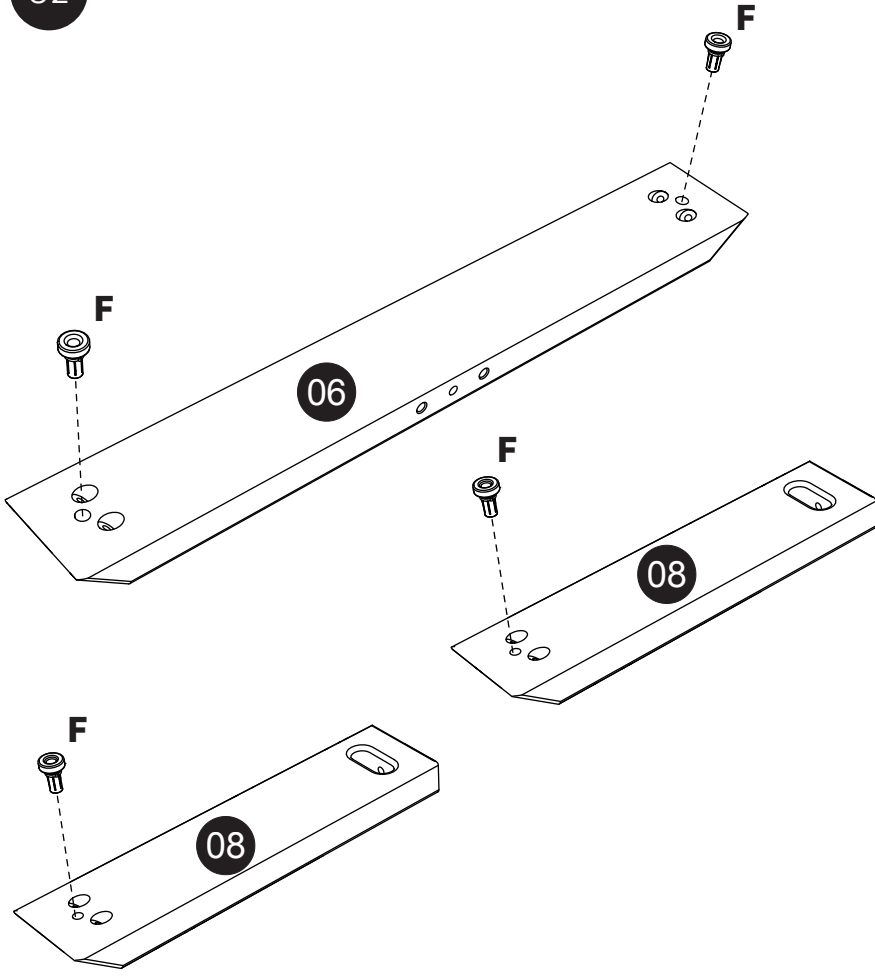





PASSO 02  
Encaixar sapata na base central **06** e travessa menor **08**.

STEP 02  
Attach plastic stopper on center base **06** and short crosspiece **08**.

PASO 03  
Montar almohadilla de plastico en la base central **06** y travesaño menor **08**.

ÉTAPE 03  
Insérez bouchonplastique et pied **06** et traverse plus petite **08**.

03

<b>A</b> COD. 11698	<b>C</b> COD. 9176	<b>E</b> COD. 9267	<b>G</b>	<b>H</b> COD. 0329
				

PASSO 03

Aplicar cola nos furos indicados para encaixar cavilhas 4x**0329**. Encaixar 1x**9187** na base central **06**.

STEP 03

Apply glue as indicated to insert dowels 4x**0329**. Insert 1x**9187** on center base **06**.

PASO 03

Aplicar pegamento en las perforaciones indicadas clavijas de ajuste 4x**0329**. Montar 1x**9187** en la base **06**.

ÉTAPE 03

Appliquez la colle sur les trous indiqués et insérez les chevilles 4x**0329**. Insérez 1x**9187** et pied **06**.

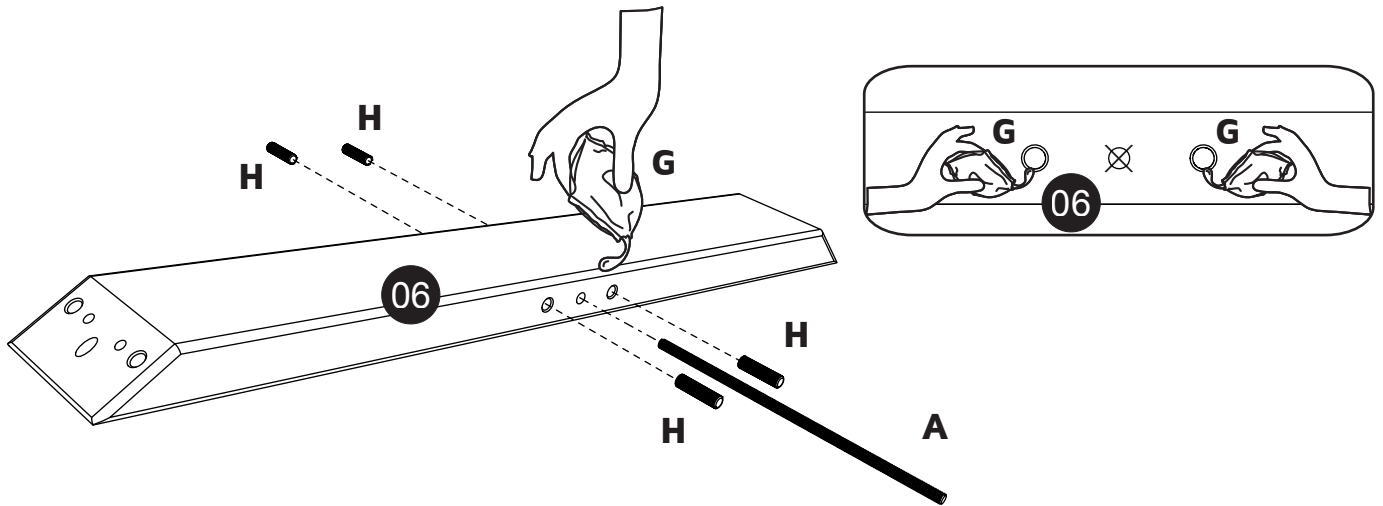

04

PASSO 04

Aplicar cola nos furos indicados para encaixar cavilhas e rosquear 1x**9176**.

STEP 04

Apply glue as indicated to insert dowels and thread 1x**9176**.

PASO 04

Aplicar pegamento en las perforaciones indicadas para montar clavijas y rosquear 1x**9176**.

ÉTAPE 04

Appliquez la colle sur les trous indiqués et insérez les chevilles et visser 1x**9176**.

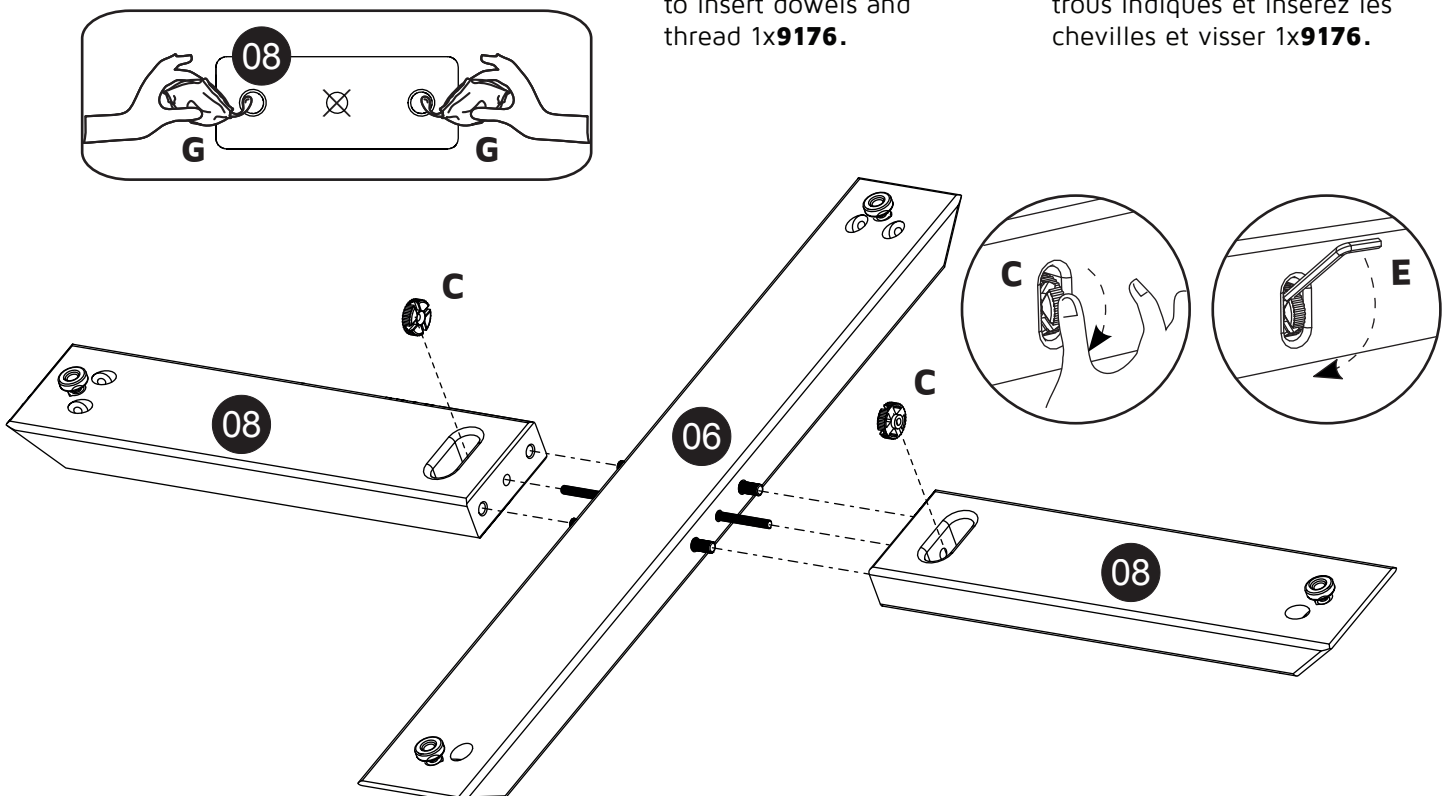

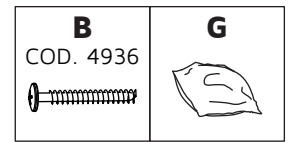
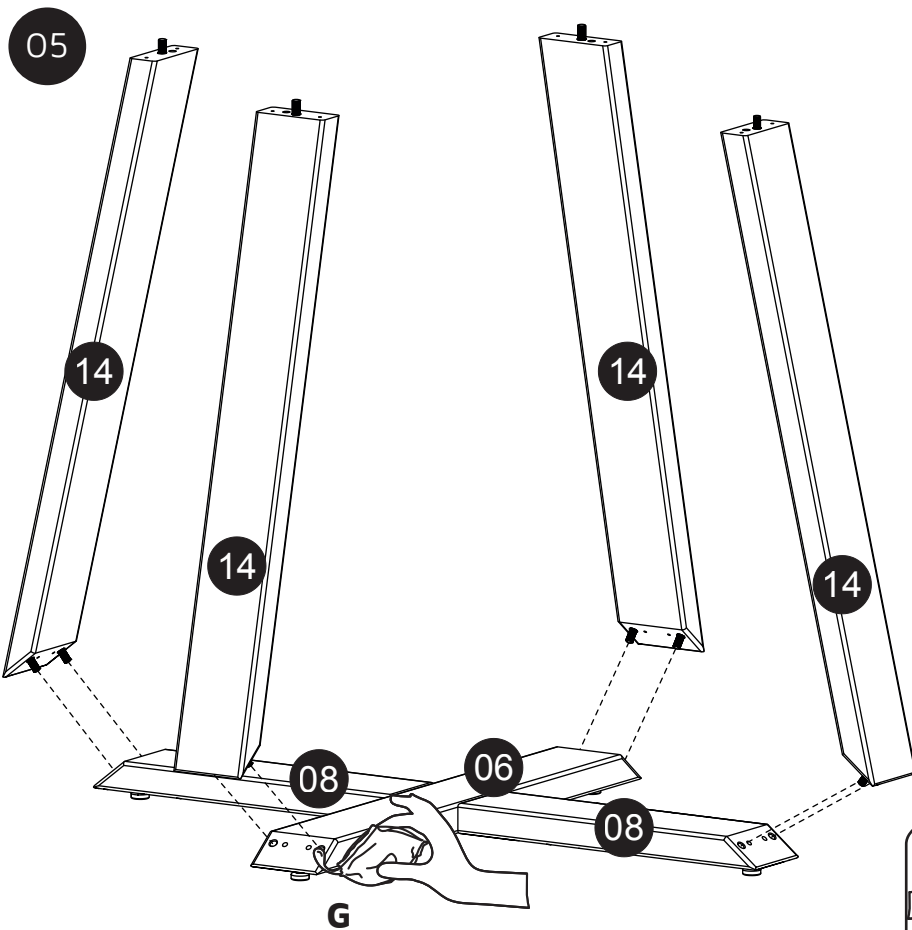

**PASSO 05**  
Aplicar cola nos furos indicados para encaixar cavilhas e montar travessas **14**.

**STEP 05**  
Apply glue as indicated to insert dowels and attach crosspieces **14**.

**PASO 05**  
Aplicar pegamento en las perforaciones indicadas para montar clavijas y montar el travesaños **14**.

**ÉTAPE 05**  
Appliquez la colle sur les trous indiqués et insérez les chevilles et insérez les traverses **14**.

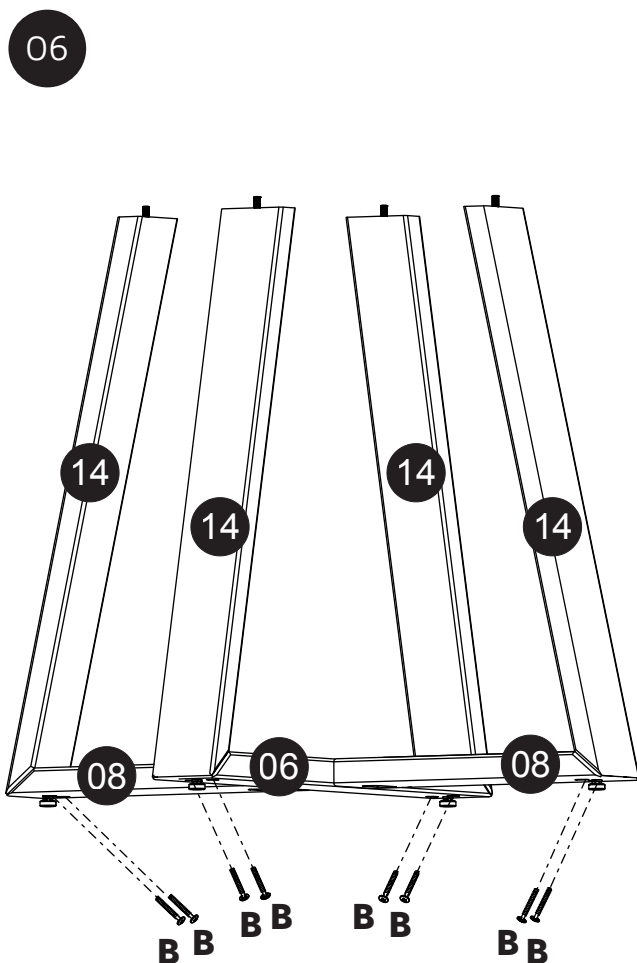
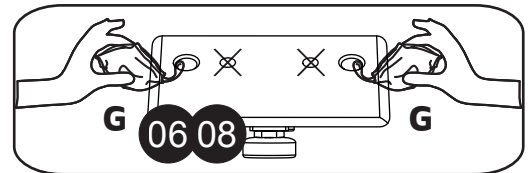

**PASSO 06**  
Parafusar 8x**4936** base central **06** e travessa menor **11**.

**STEP 06**  
Screw 8x**4936** center base **06** and short crosspiece **11**.

**PASO 06**  
Atornillar 8x**493** base central **06** y travesaño menor **11**.

**ÉTAPE 06**  
Vissez 8x**4936** base centrale **06** et traverse plus petite **11**.

**Atenção**  
**Attention**  
**Atención**  
**Attention**

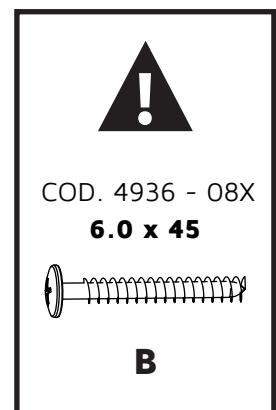
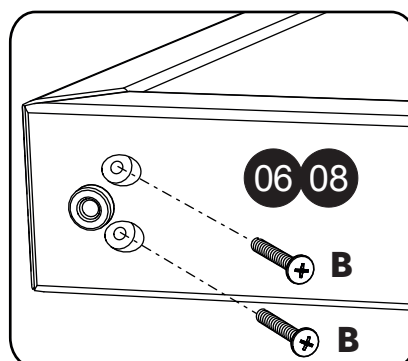

07

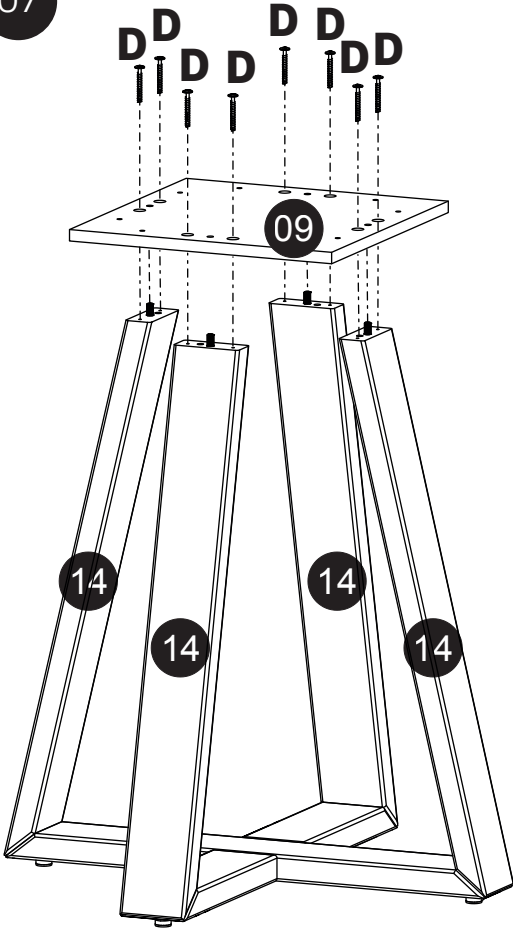

PASSO 07  
Parafusar 8x**11701** sub-tampo **09**.

STEP 07  
Screw 8x**11701** lower cover **09**.

PASO 07  
Atornillar 8x**11701** cubierta inferior **09**.

ÉTAPE 07  
Vissez 8x**11701** dessus **09**.

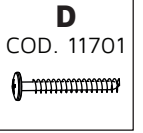

**Atenção**  
Attention  
Atención  
Attention

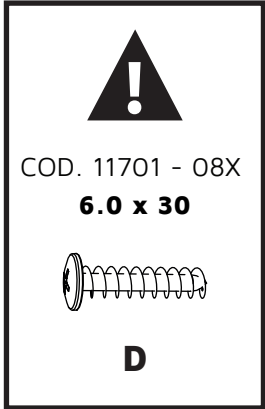

08

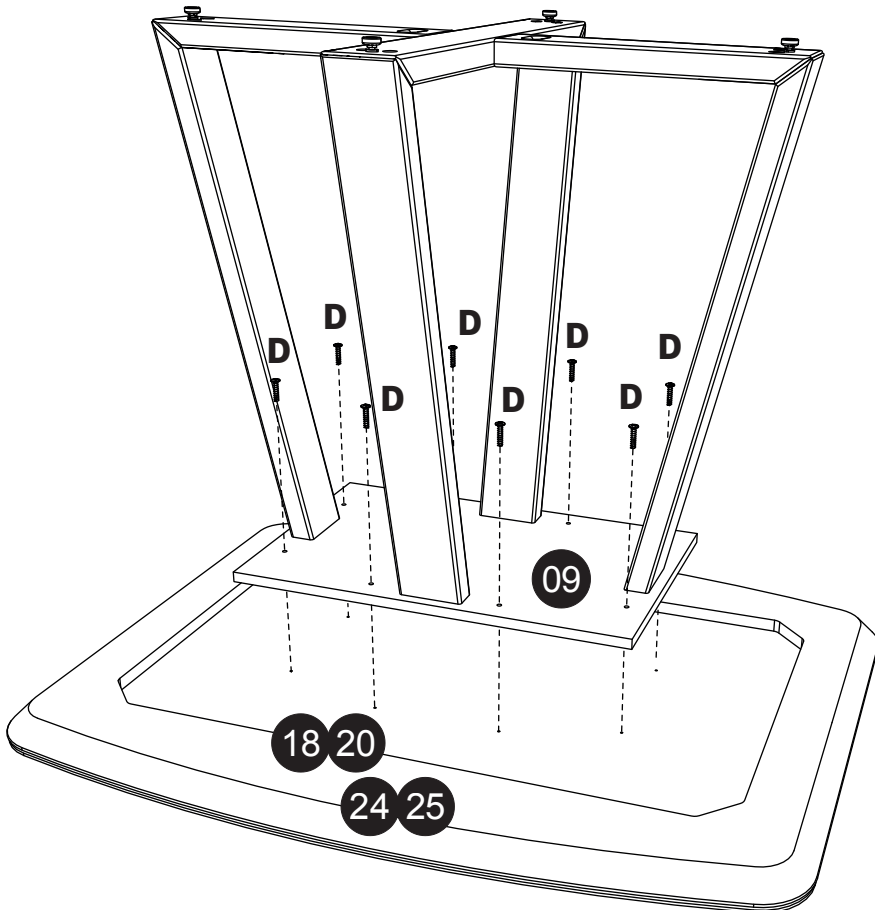

PASSO 08  
Parafusar 8x**11701** sub-tampo **09**.

STEP 08  
Screw 8x**11701** lower cover **09**.

PASO 08  
Atornillar 8x**11701** cubierta inferior **09**.

ÉTAPE 08  
Vissez 8x**11701** dessus **09**.

**Atenção**  
Attention  
Atención  
Attention

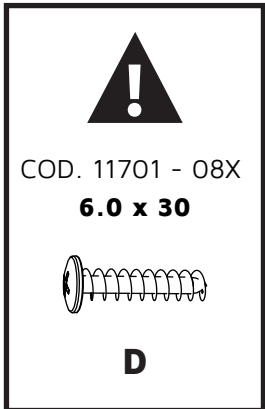

# Atenção

## Attention

## Atención

## Attention



