

# MANUAL DE MONTAGEM

ASSEMBLY INSTRUCTIONS

INSTRUCCIONES DE MONTAJE

NOTICE DE MONTAGE

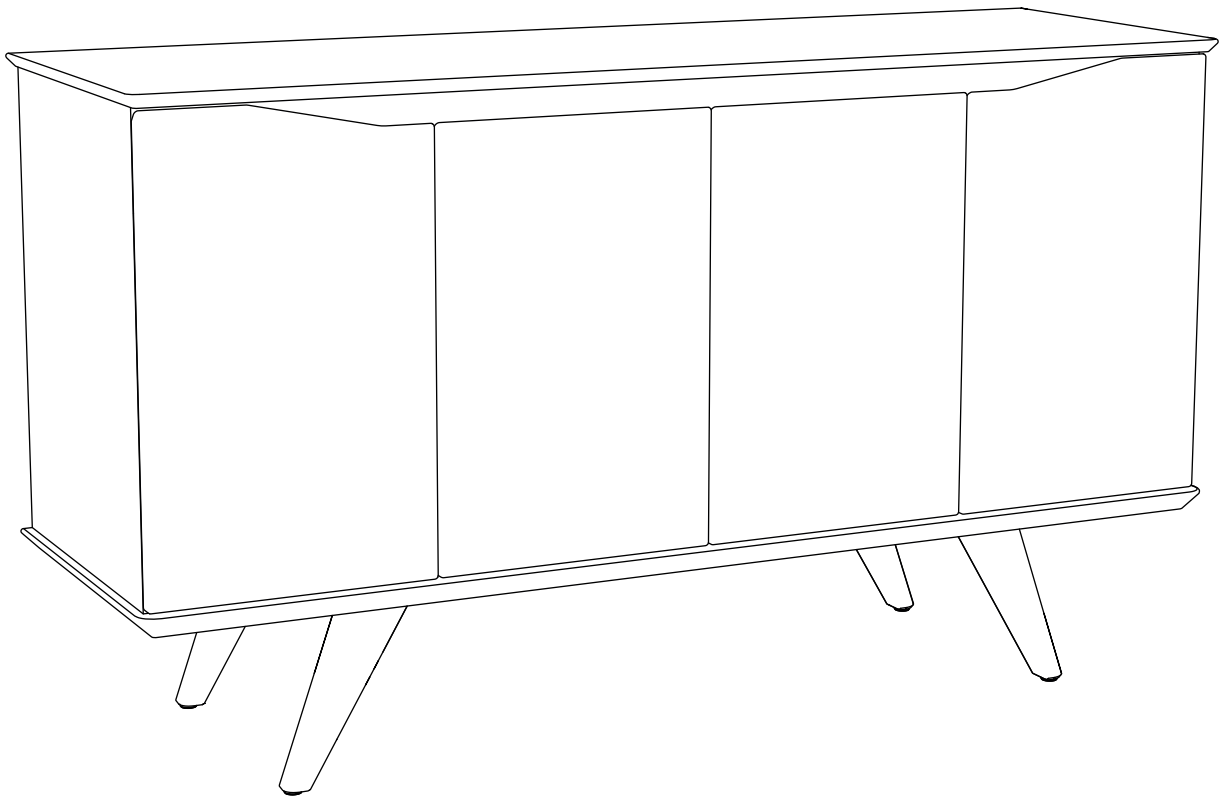

COD:1027700

COD:1024300

REV. 05 - 06/06/23

# OBSERVAÇÕES IMPORTANTES IMPORTANT REMARKS OBSERVACIONES IMPORTANTES REMARQUES IMPORTANTES



Nunca escale ou se apoie sobre o móvel. Você pode sofrer graves acidentes.

Never climb or lean on the furniture. You may suffer serious accidents.

Nunca escale o apoie sobre el mobiliario. Usted puede sufrir graves accidentes.

Ne montez jamais sur le meuble. Vous pourriez subir un grave accident.

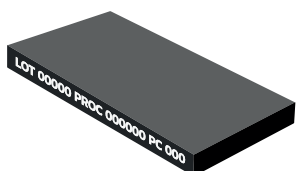

Observe os números impressos nas bordas para identificar as peças.

Identify the parts by observing the number printed on their edges.

Identifique las piezas observando el numero impreso en sus bordes.

Notez les numéros imprimés sur les bords pour identifier les pièces.



Movimente o móvel com cuidado, sem arrastar. Peça ajuda a outra pessoa para fazê-lo.

Move the piece carefully, don't drag it. Ask for someone else's help to do so.

Mover la unidad con cuidado, sin arrastar. Pedir ayuda da otra persona para moverlo.

Déplacez les meubles avec précaution sans le faire glisser. Demandez a quelqu'un de vous aider à le faire.

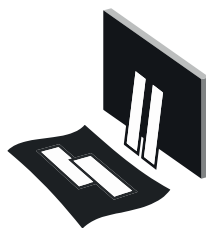

Utilize a embalagem para forrar a área de montagem e separar todas as peças.

Use the packaging to cover the assembly area and separate all parts.

Utilice el embalaje para cubrir la area de montaje y separe las piezas.

Couvrez la zone d'assemblage avec l'emballage pour séparer le pièces.



Limpe com um pano limpo e umedecido em água e sabão neutro. Não utilizar produtos químicos e abrasivos.

Wipe clean using a damp cloth and a mild cleaner. Don't use abrasive and chemical products.

Limpie con un paño limpio humedecido con agua y jabón neutro. No utilice productos químicos y abrasivos.

Nettoyez avec un chiffon propre imbibé avec d'eau et de savon doux. N'utilisez pas de produits chimiques et abrasifs.



Não colocar objetos em alta temperatura diretamente sobre superfícies de vidro.

Do not place high-temperature objects directly on glass surfaces.

No coloque objetos de alta temperatura directamente sobre superficies de vidro.

Ne placez pas d'objets à haute température directement sur les surfaces en verre.

# ACESSÓRIOS HARDWARE HERRAJES ACCESSOIRES

Identifique e separe os acessórios utilizados. Em cada embalagem, uma etiqueta identifica as peças e onde utilizá-las.

Identify and separate the hardware used in the assembly. There's a label on each package identifying the parts and where to use them.

Identifique y separe los accesorios utilizados en el montaje. Observe la etiqueta en cada paquete para saber donde montar.

Identifiez et séparez les accessoires à être utilisés. Dans chaque emballage il y a une étiquette pour identifier les pièces et où les utiliser.

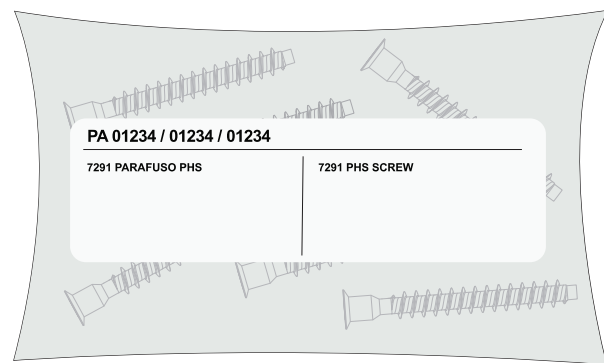

---

## 1350 mm









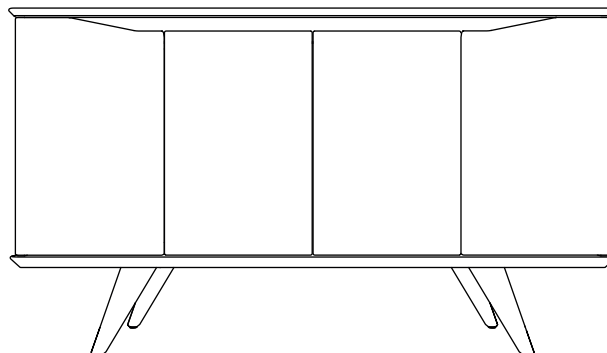

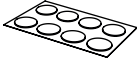





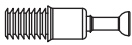

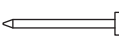
L:1350mm A:779mm P:443mm

W:53.15in H:30.66in D:17.44in

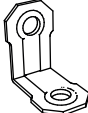
L:1350mm A:779mm P:443mm

L:1350mm H:779mm P:443mm

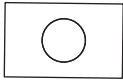
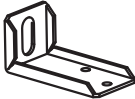

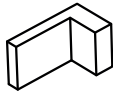
<p><b>A</b>  ADESIVO  STICKER  ADHESIVO  AUTOCOLLANT  (10X)</p> 	<p><b>B</b>  COD. 7531  <b>M4 x 14</b>  (04X)</p> 	<p><b>C</b>  COD. 10063  <b>5.0 x 50</b>  (06X)</p> 	<p><b>D</b>  COD. 1668  <b>6.0 x 30</b>  (20X)</p> 	<p><b>E</b>  COD. 9292  <b>8.0 x 50</b>  (04X)</p> 
<p><b>F</b>  COD. 7519  <b>4.5 x 16</b>  (32X)</p> 	<p><b>G</b>  COD. 9895  (06X)</p> 	<p><b>H</b>  COD. 7702  <b>M4 x 10</b>  (08X)</p> 	<p><b>I</b>  COD. 0357  <b>8.0 x 8.0</b>  (54X)</p> 	<p><b>J</b>  COD. 0342  (12X)</p> 
<p><b>K</b>  COD. 2510  (04X)  DOBRADICA INTERNA  INNER HINGES  BISAGRAS INTERNAS  CHARNIÈRES INTÉRIEURES</p> 	<p><b>L</b>  COD. 2511  (04X)  DOBRADICA EXTERNA  OUTER HINGES  BISAGRAS EXTERNAS  CHARNIÈRES EXTÉRIEURES</p> 	<p><b>M</b>  COD. 6244  <b>6.0 x 65</b>  (06X)</p> 	<p><b>N</b>  COD. 1669  (04X)</p> 	<p><b>O</b>  COD. 1533  <b>4.0 x 14</b>  (08X)</p> 
<p><b>P</b>  COD. 9509  (01X)</p> 	<p><b>Q</b>  SAPATA  PLASTIC STOPPER  ALMOHADILLA DE PLASTICO  BOUCHON PLASTIQUE  (04X)</p> 	<p><b>R</b>  COD. 12952  (04X)</p> 	<p><b>S</b>  COD. 3934  (02X)</p> 	<p><b>T</b>  COD. 3557  (06X)</p> 
<p><b>U</b>  COD. 2088  (02X)</p> 	<p><b>V</b>  COD. 5681  (02X)</p> 			

MONTAGEM NECESSITA 2 PESSOAS  
ASSEMBLY REQUIRES 2 PEOPLE  
EL MONTAJE NECESITA 2 PERSONAS  
MONTAGE A 2 PERSONNES

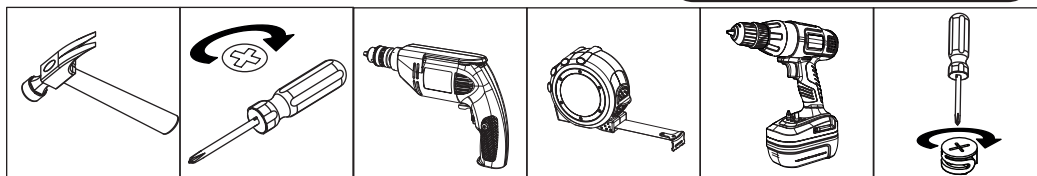

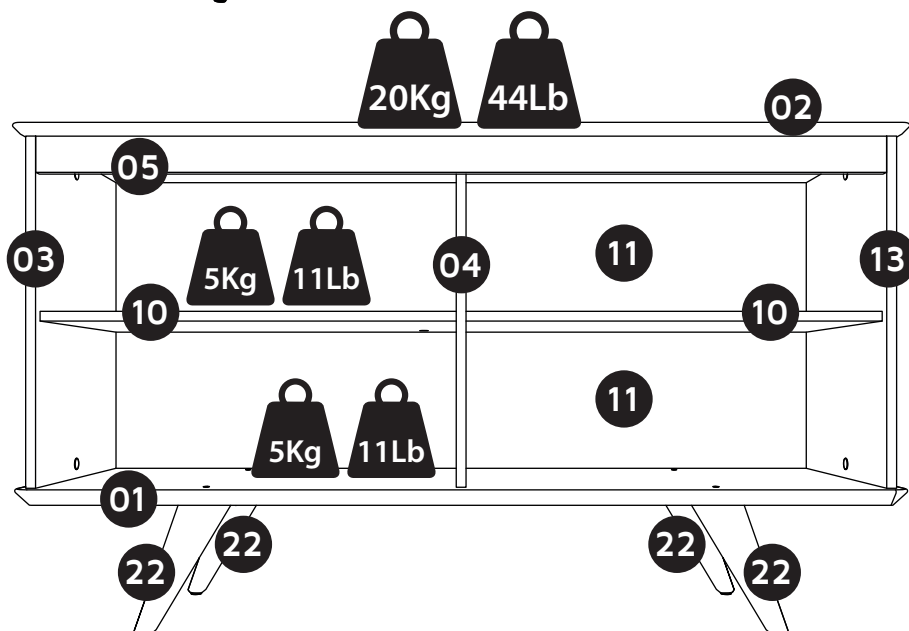
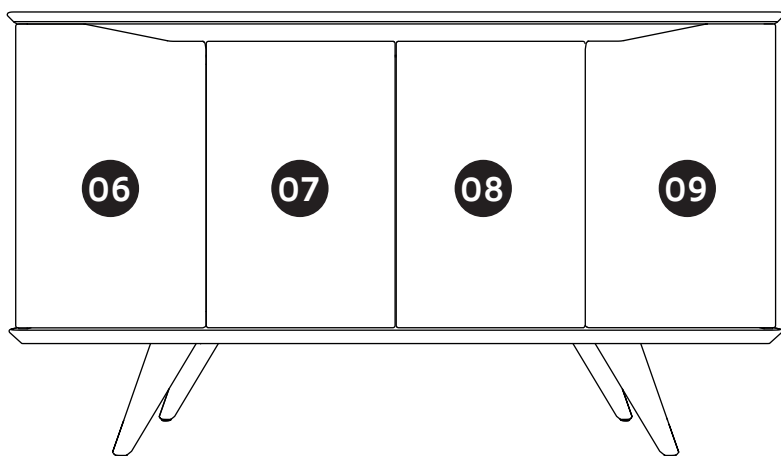

## DESCRIÇÃO/ DESCRIPTION/ DESCRIPCIÓN/ DESCRIPTION

<b>CÓD: 1027700/ 1024300</b>						
<b>PEÇA</b> <small>PART PIEZA PIÈCE</small>	<b>QUANTIDADE</b> <small>QUANTITY CANTIDAD QUANTITÉ</small>	<b>DESCRIÇÃO</b>	<b>DESCRIPTION</b>	<b>DESCRIPCIÓN</b>	<b>DESCRIPTION</b>	<b>CAIXA</b> <small>BOX CAJA BOÎTE</small>
<b>01</b>	<b>01</b>	BASE	BASE	BASE	BASE	01
<b>02</b>	<b>01</b>	TAMPO	TOP PANEL	CUBIERTA	PLATEAU	01
<b>03</b>	<b>01</b>	LATERAL ESQUERDA	LEFT SIDE	LATERAL IZQUIERDA	CÔTÉ GAUCHE	01
<b>04</b>	<b>01</b>	DIVISÓRIA	DIVIDER	DIVISOR	DIVISEUR	01
<b>05</b>	<b>01</b>	TRAVESSA	CROSSPIECE	TRAVESAÑO	BARREAU	01
<b>06</b>	<b>01</b>	PORTA ESQUERDA	LEFT DOOR	PUERTA IZQUIERDA	PORTE GAUCHE	01
<b>07</b>	<b>01</b>	PORTA CENTRAL ESQ.	LEFT CENTRAL DOOR	PUERTA CENTRAL IZQ	PORTE CENTRALE GAUCHE	01
<b>08</b>	<b>01</b>	PORTA CENTRAL DIR.	RIGHT CENTRAL DOOR	PUERTA CENTRAL DER	PORTE CENTRALE DROITE	01
<b>09</b>	<b>01</b>	PORTA DIREITA	RIGHT DOOR	PUERTA DERECHA	PORTE DROITE	01
<b>10</b>	<b>02</b>	PRATELEIRA	TOP SHELF	ESTANTE	ÉTAGÈRE	01
<b>11</b>	<b>02</b>	FUNDO	BLACK PLATE	FONDO	FOND	01
<b>13</b>	<b>01</b>	LATERAL DIREITA	RIGHT SIDE	LATERAL DERECHA	CÔTÉ DROITE	01
<b>22</b>	<b>04</b>	PÉ	LEG	PATA	PIED	01



01

**G**  
 COD. 9895  

PASSO 01  
 Parafusar minifix 3x**9895**  
 na base **01**.

PASO 01  
 Atornillar el minifix 3x**9895**  
 en la base **01**.

STEP 01  
 Screw minifix 3x**9895**  
 on base **01**.

ÉTAPE 01  
 Vissez le minifix 3x**9895**  
 dans la base **01**.

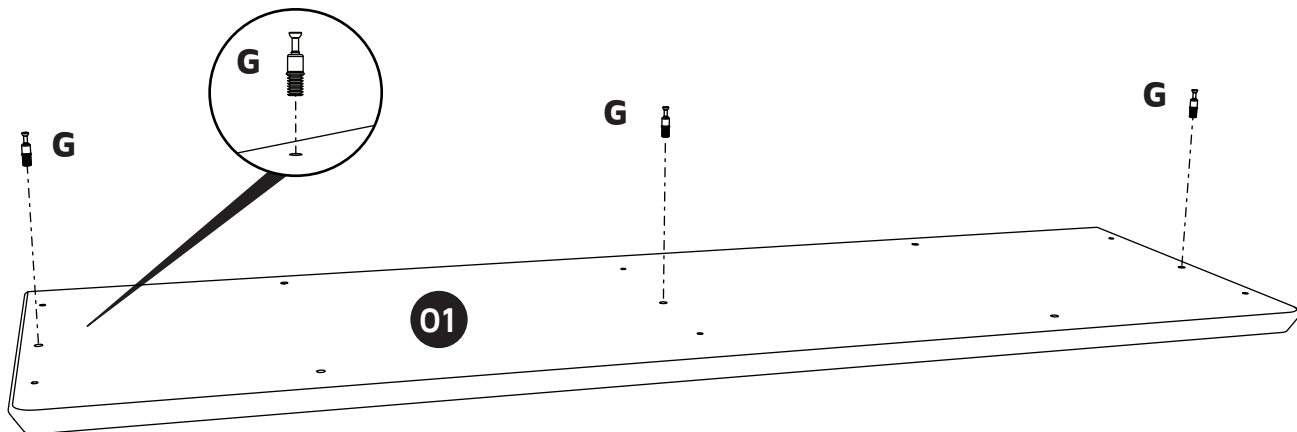

02

PASSO 02  
 Parafusar minifix 3x**9895**  
 no tampo **02**.



PASO 02  
 Atornillar el minifix 3x**9895**  
 en la cubierta **02**.

STEP 02  
 Screw minifix 3x**9895**  
 on top panel **02**.

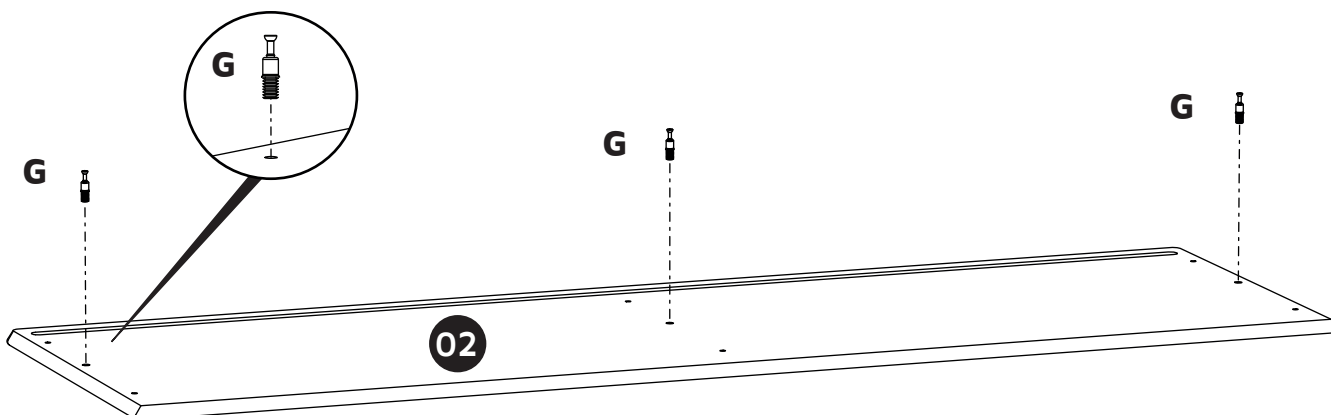
ÉTAPE 02  
 Vissez le minifix 3x**9895**  
 dans plateau **02**.



03

<b>B</b> COD. 7531	<b>D</b> COD. 1668
	

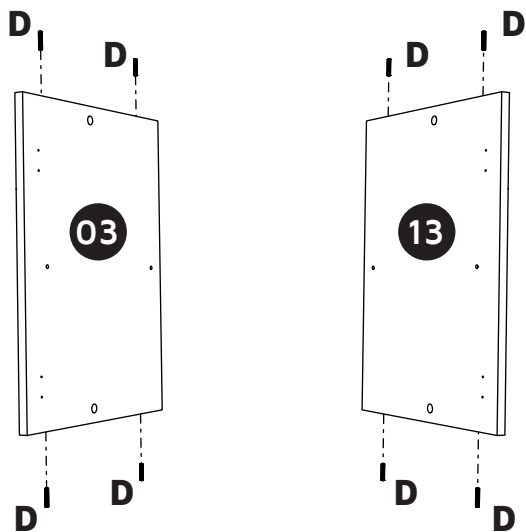

## PASSO 03

Encaixar cavilhas 4x**1668** na lateral esq. **03**/  
lateral direita **13**/ prateleira **10**.

## STEP 03

Insert dowels 4x**1668** on the left side **03**/  
right side **13**/ top shelf **10**.

## PASO 03

Clavijas de ajuste 4x**1668** en lateral  
izquierda **03**/ lateral derecha **13**/ estante **10**.

## ÉTAPE 03

Insérez les chevilles 4x**1668** dans côté  
gauche **03**/ côté droite **13**/ étagère **10**.

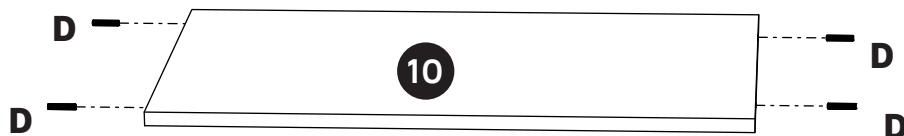

04

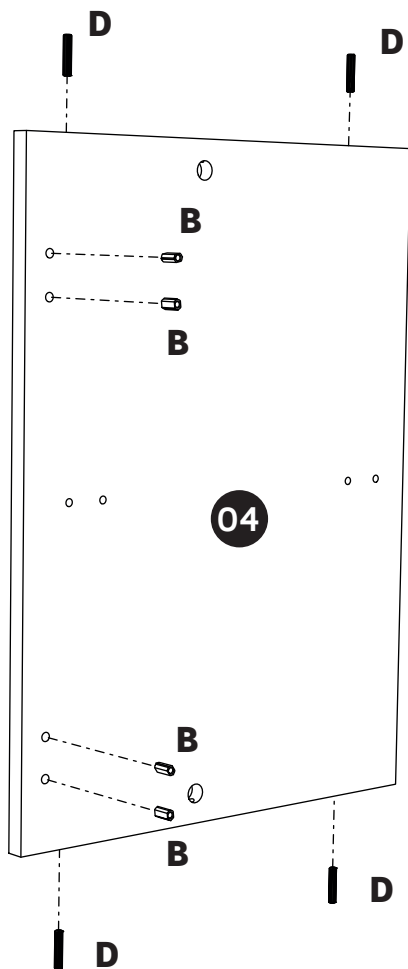

## PASSO 04

Encaixar cavilhas 4x**1668**/ 4x**7531** na  
divisória **04**.

## STEP 04

Insert dowels 4x**1668**/ 4x**7531**  
on the divider **04**.





## PASO 04

Clavijas de ajuste 4x**1668**/ 4x**7531**  
en divisor **04**.

## ÉTAPE 04

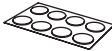
Insérez les chevilles 4x**1668**/ 4x**7531**  
et diviseur **04**.

05

<b>A</b> 	<b>E</b> COD. 9292 	<b>M</b> COD. 6244 	<b>P</b> 	<b>Q</b> 
---	---	--	---	---

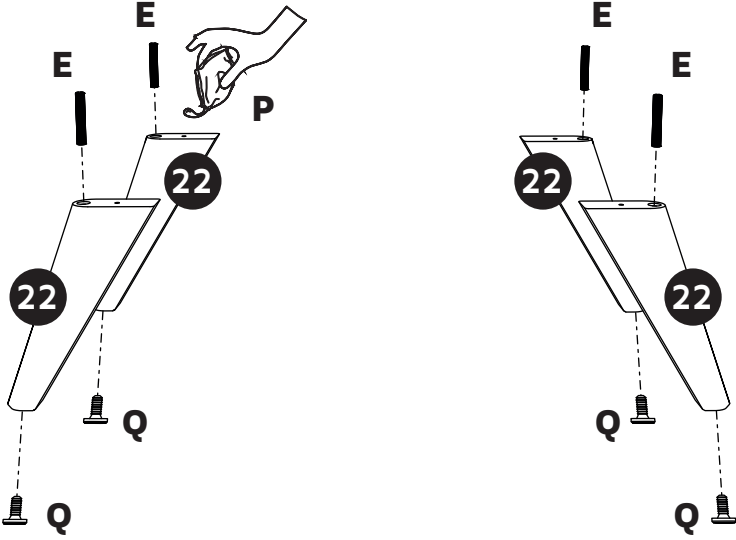

PASSO 05  
Encaixar cavilha 1x**9292** e parafusar sapata nos pés **22**.

STEP 05  
Insert dowels 1x**9292** and screw plastic stopper on legs **22**.

PASO 05  
Enganchar clavijas de ajuste 1x**9292** y atornillar la almohadilla de plástico en las patas **22**.

ÉTAPE 05  
Insérez les chevilles 1x**9292** et vissez le bouchon plastique dans pieds **22**.

06

PASSO 06  
Encaixar base **01** nos pés **22**, parafusar 4x**6244** e colar **4** adesivos.

STEP 06  
Attach base **01** on legs **22**, screw 4x**6244** and place **4** stickers.

PASO 06  
Montar base **01** en las patas **22**, atornillar 4x**6244** y pegar **4** adhesivos.

ÉTAPE 06  
Insérez base **01** et pieds **22**, vissez 4x**6244** et collez **4** l'adhésif.

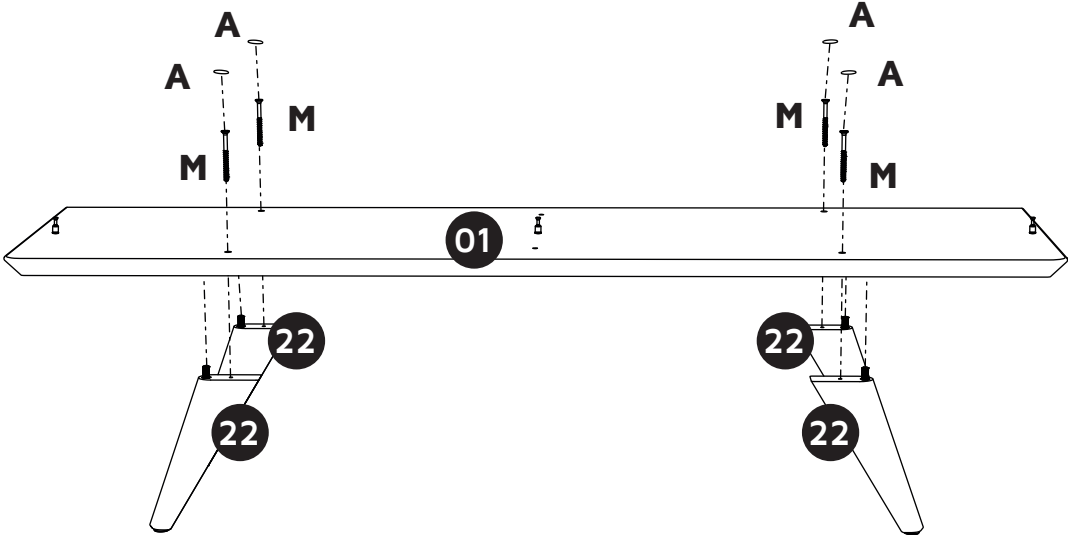



07

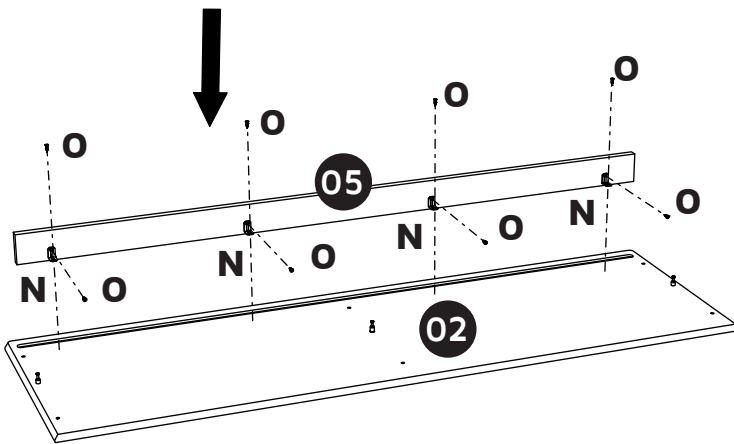
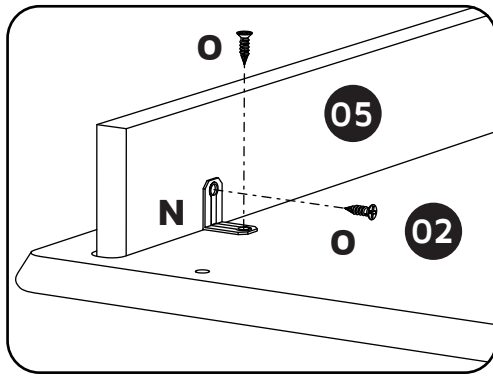

<b>A</b> 	<b>C</b> COD. 10063 	<b>N</b> COD. 1669 	<b>O</b> COD. 1533 
--------------	----------------------------	---------------------------	---------------------------

## PASSO 07

Encaixar travessa **05** no tampo **02** e parafusar 8x**1533** nas cantoneiras 4x**1669**.

## STEP 07

Attach crosspiece **05** on top panel **02** and screw 8x**1533** on angle 4x**1669**.

## PASO 07

Montar travesaño **05** en la cubierta **02** y atornillar 8x**1533** en el ángulo 4x**1669**.

## ÉTAPE 07

Insérez barreau **05** sur le plateau **02** et vissez 8x**1533** dans le angle 4x**1669**.

08

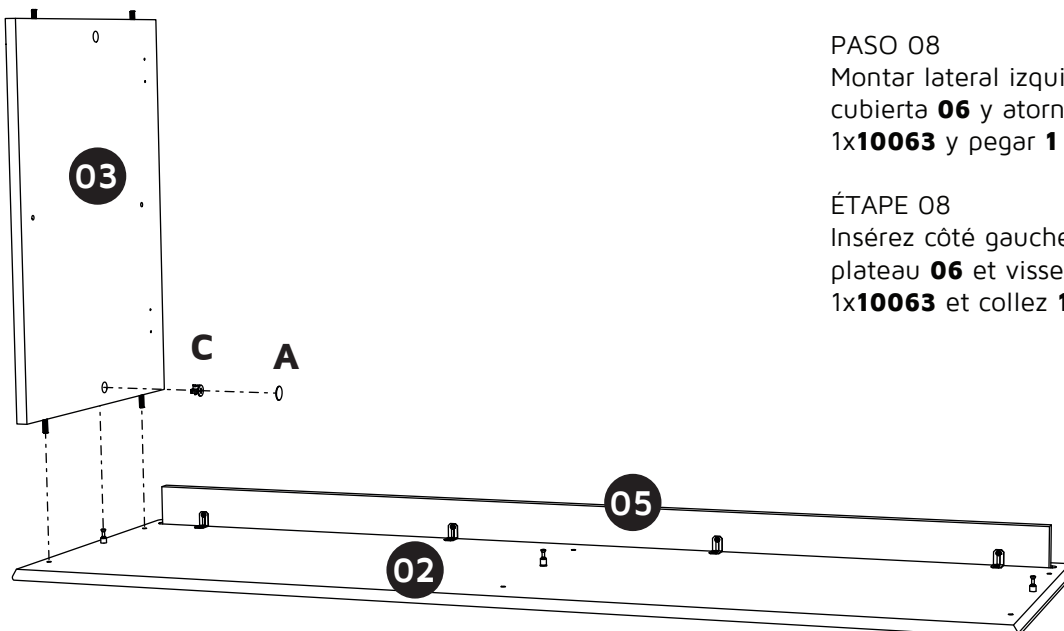

## PASSO 08

Encaixar lateral esquerda **03** no tampo **06** e parafusar castanha 1x**10063** e colar **1** adesivo.

## STEP 08

Attach left side **03** on top panel **02** and screw nuts 1x**10063** and place **2** stickers.

## PASO 08

Montar lateral izquierda **03** en la cubierta **06** y atornillar la tuerca 1x**10063** y pegar **1** adhesivo.

## ÉTAPE 08

Insérez côté gauche **03** dans le plateau **06** et vissez le brunette 1x**10063** et collez **1** l'adhésif.

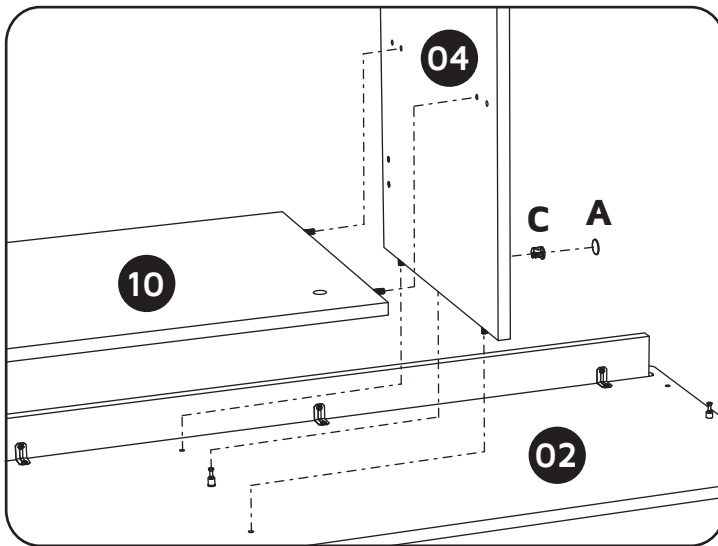
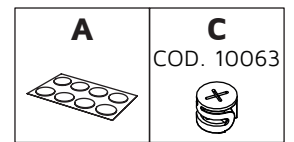

## PASSO 09

Encaixar prateleira **10** e divisória **04**.

Parafusar castanha 1x**10063** e colar **1** adesivo na divisória **04**.

## STEP 09

Attach top shelf **10** and divider **04**.

Screw nut 1x**10063** and place **1** sticker on divider **04**.

## PASO 09

Montar estante **10** y divisor **04**.

Atornillar la tuerca 1x**10063** y pegar **1** adhesivo en el divisor **04**.

## ÉTAPE 09

Insérez étagère **10** et diviseur **04**.

Vissez le brunette 1x**10063** et collez **1** l'adhésif dans le diviseur **04**.

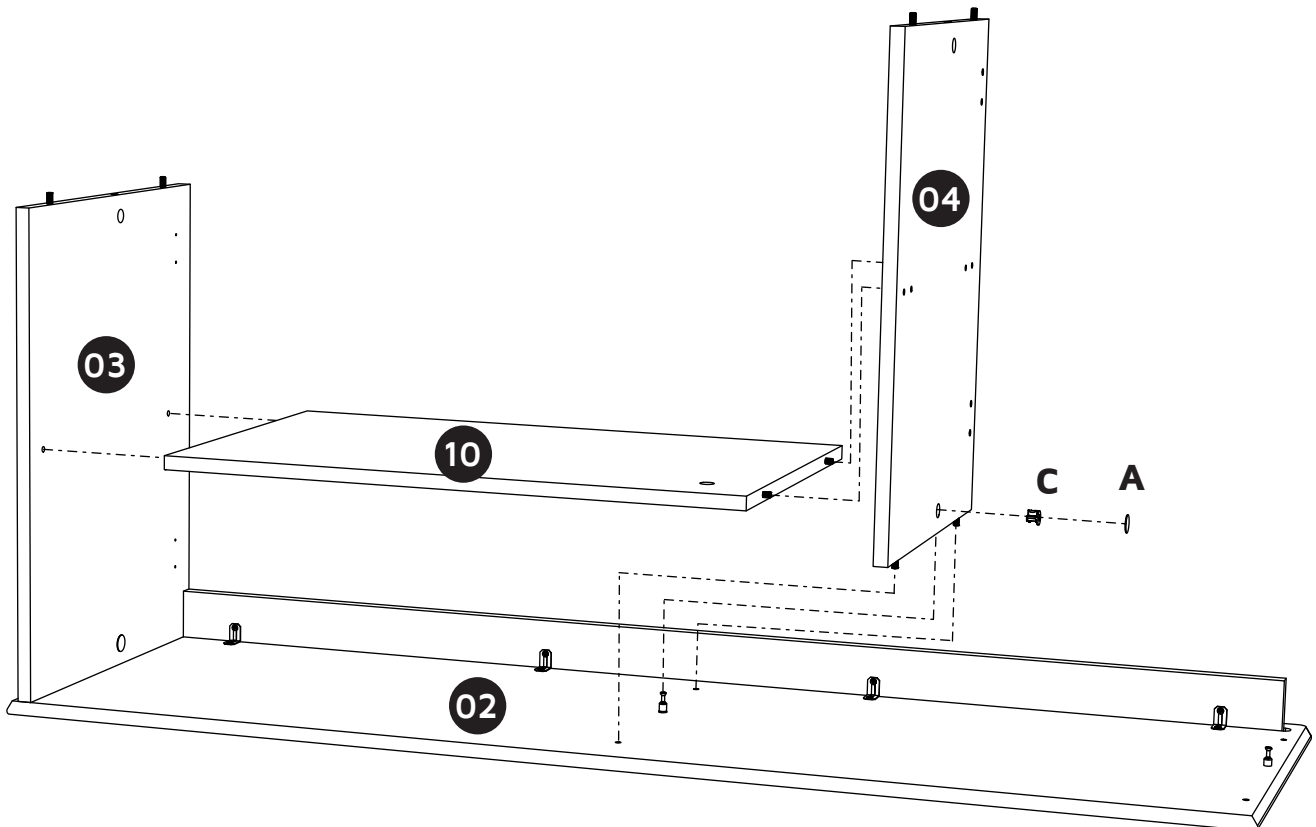

10

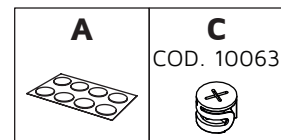

## PASSO 10

Encaixar prateleira **10** e lateral direita **13**.  
Parafusar castanha 1x**10063** e colar **1** adesivo na lateral direita **13**.

## STEP 10

Attach top shelf **10** and right side **13**.  
Screw nut 1x**10063** and place **1** sticker on right side **13**.

## PASO 10

Montar estante **10** y lateral derecha **13**.  
Atornillar la tuerca 1x**10063** y pegar **1** adhesivo en la lateral derecha **13**.

## ÉTAPE 10

Insérez étagère **10** et côté droite **13**.  
Vissez le brunette 1x**10063** et collez **1** l'adhésif dans le côté droite **13**.

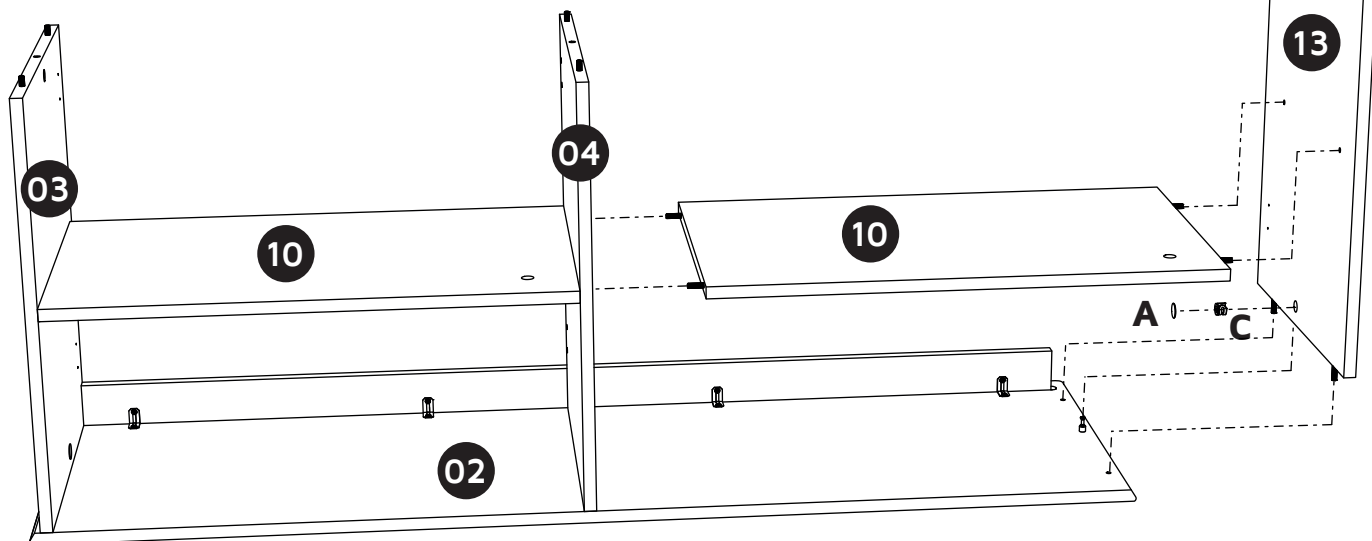

11

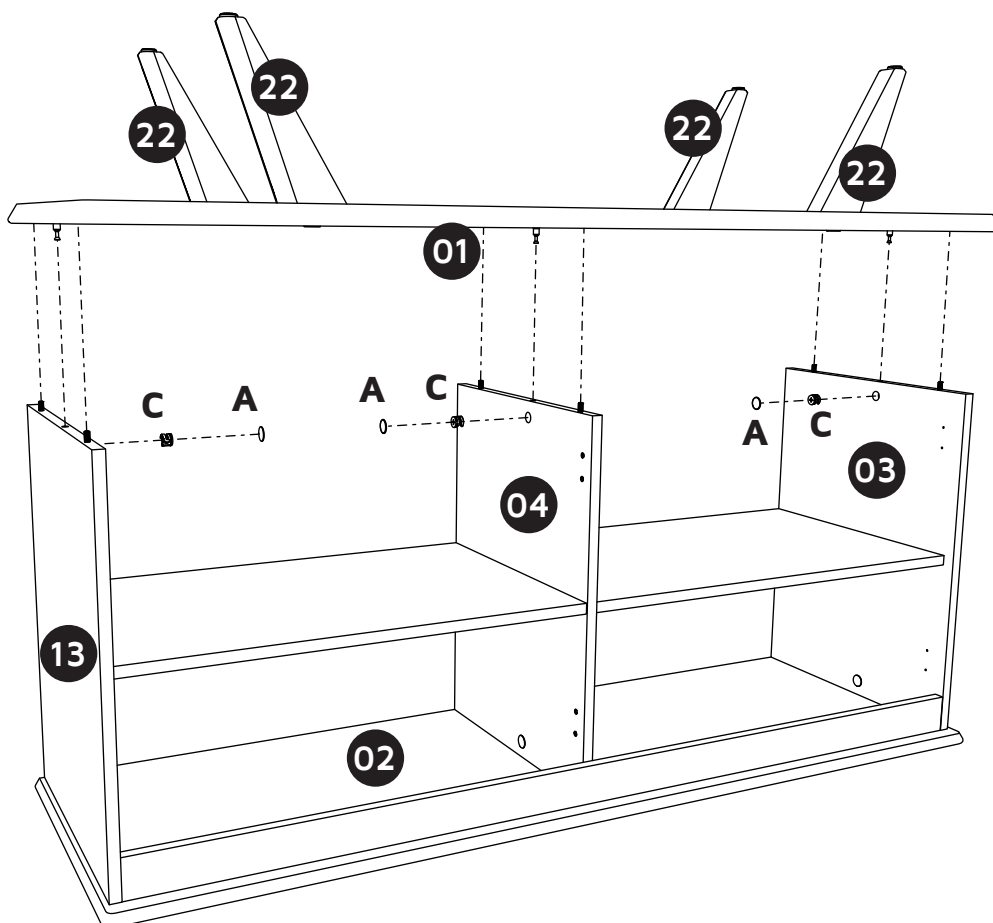

## PASSO 11

Encaixar base **01**, parafusar castanhas 3x**10063** e colar **3** adesivos.

## STEP 11

Attach base **01**, screw nuts 3x**10063** and place **3** stickers.

## PASO 11

Montar base **01**, atornillar las tuercas 3x**10063** y pegar **3** adhesivos.

## ÉTAPE 11

Insérez base **01**, vissez le brunette 3x**10063** et collez **3** l'adhésif.

12

<b>I</b> COD. 0357	<b>J</b> COD. 0342	<b>M</b> COD. 6244	<b>S</b> COD. 3934	<b>T</b> COD. 3557	<b>U</b> COD. 2088	<b>V</b> COD. 5681

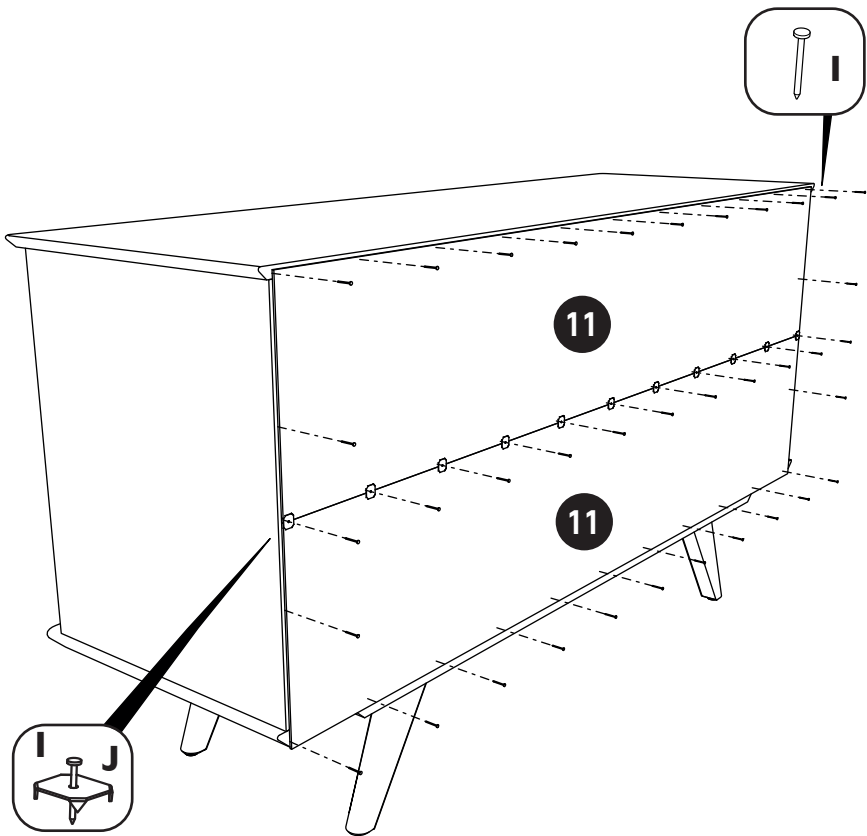

PASSO 12  
Encaixar fundo **11** pregar **0357/ 0342**

STEP 12  
Attach backplate **11** nailing **0357/ 0342**

PASO 12  
Enganchar el fondo **11** clavar **0357/ 0342**

ÉTAPE 12  
Insérez fond **11** prêcher **0357/ 0342**

13

**É obrigatório fixar este acessório de segurança.**





It's mandatory to fix this safety device.

Es obligatorio adjuntar este accesorio de seguridad.

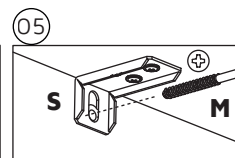
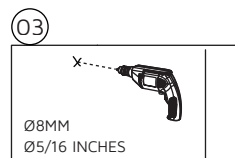
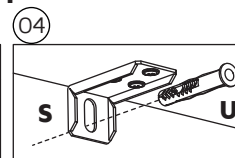
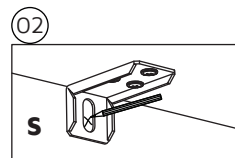
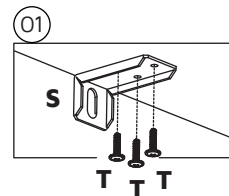
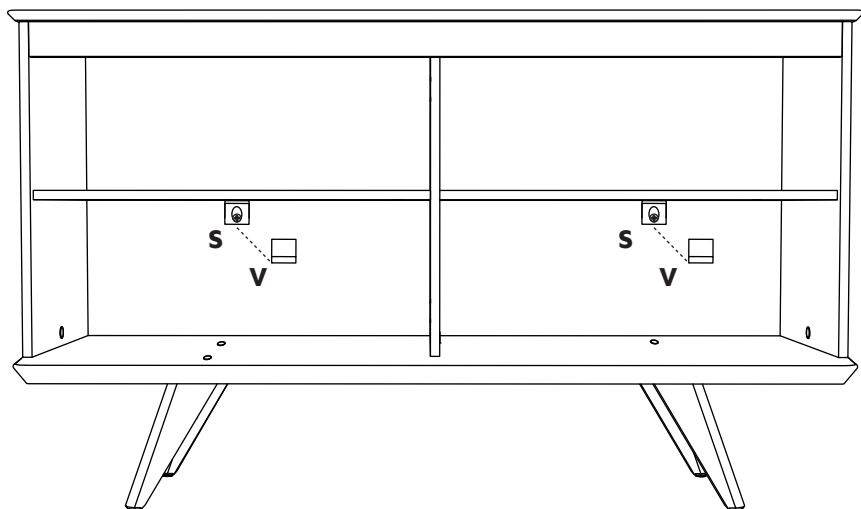
Il est obligatoire de fixer cet accessoire de sécurité.



<b>F</b> COD. 7519	<b>L</b> COD. 2511
	



**Atenção**  
Attention  
Atención  
Attention

**DOBRADIÇAS EXTERNAS**  
OUTER HINGES  
BISAGRAS EXTERNAS  
CHARNIÈRES EXTÉRIEURES

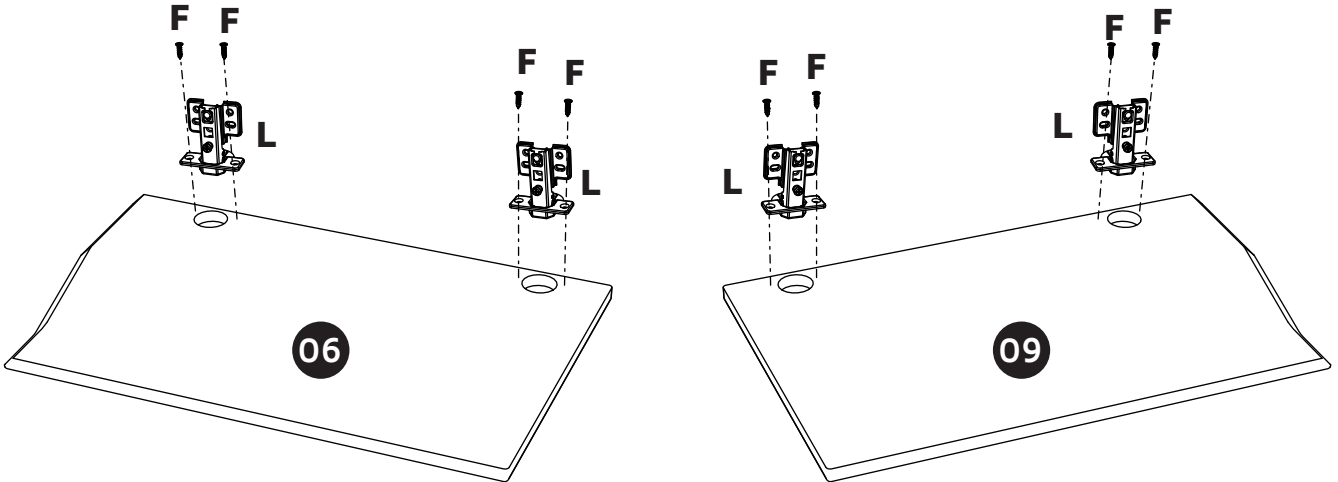
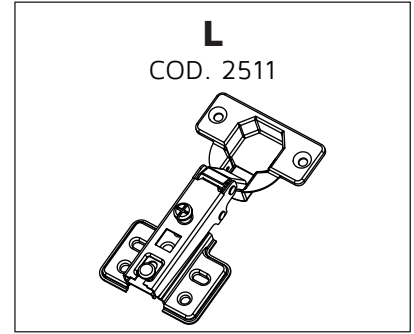



**Atenção**  
Attention  
Atención  
Attention

**DOBRADIÇA EXTERNA**  
OUTER HINGES  
BISAGRAS EXTERNAS  
CHARNIÈRES EXTÉRIEURES

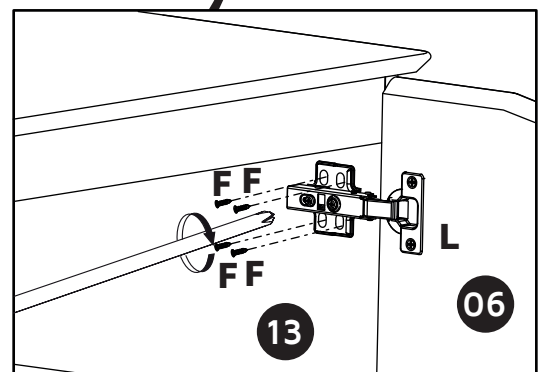
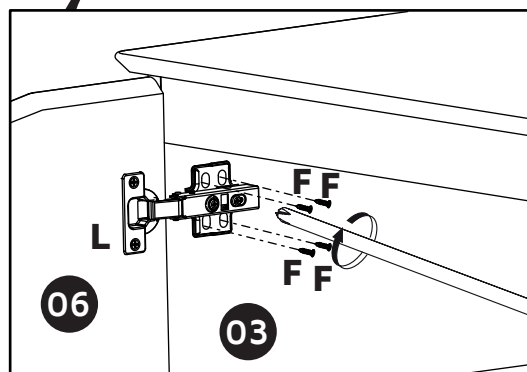
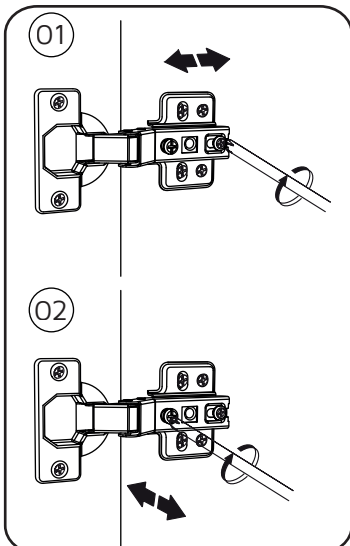
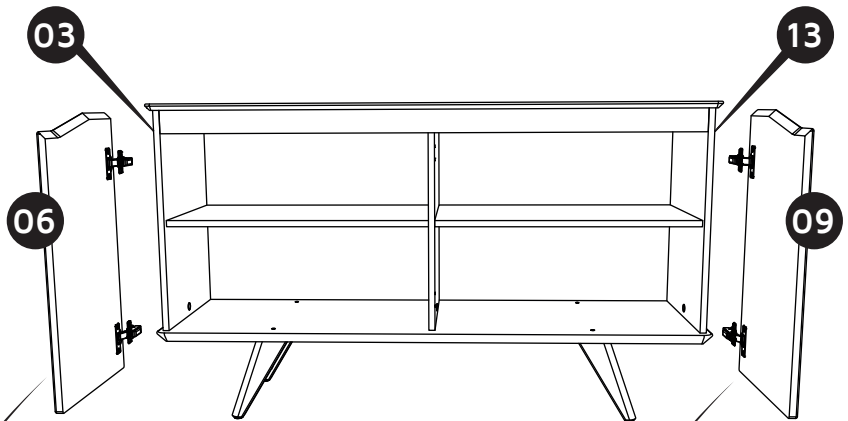
**AJUSTE DAS DOBRADIÇAS**  
HINGE ADJUSTMENT  
AJUSTE DE LAS BISAGRAS  
RÉGLAGE DES CHARNIÈRES



<b>F</b> COD. 7519	<b>H</b> COD. 7702	<b>K</b> COD. 2510
		



**Atenção**  
Attention  
Atención  
Attention

**DOBRADIÇAS INTERNAS**  
INNER HINGES  
BISAGRAS INTERNAS  
CHARNIÈRES INTÉRIEURES

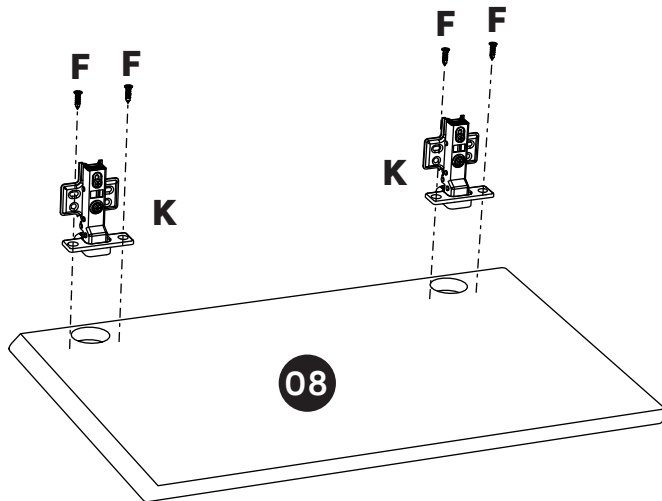
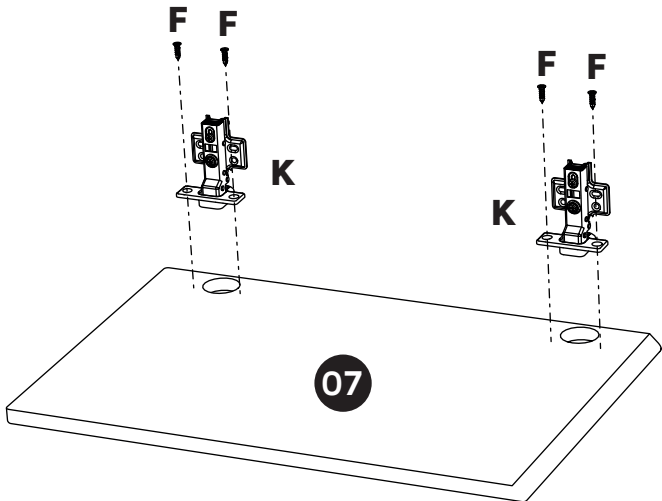
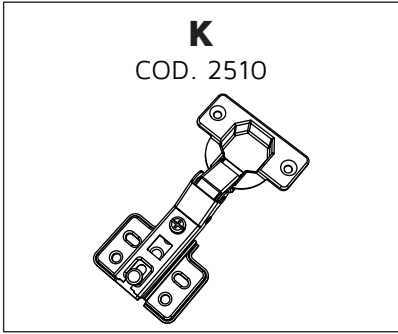

**Atenção**  
Attention  
Atención  
Attention

**DOBRADIÇA INTERNA**  
INNER HINGES  
BISAGRAS INTERNAS  
CHARNIÈRES INTÉRIEURES

**AJUSTE DAS DOBRADIÇAS**  
HINGE ADJUSTMENT  
AJUSTE DE LAS BISAGRAS  
RÉGLAGE DES CHARNIÈRES

