

HENN

Ind. e Com. de Móveis Henn
Mondai - SC - Brasil

+55 49 3674.3500

@moveishenn
www.henn.com.br

INSTRUÇÕES DE MONTAGEM

INSTRUCCIONES DE MONTAJE
ASSEMBLY INSTRUCTIONS

Base Mesa Epic | Base de Mesa Epic | Epic Table Base S412-127 Nature/OFF White

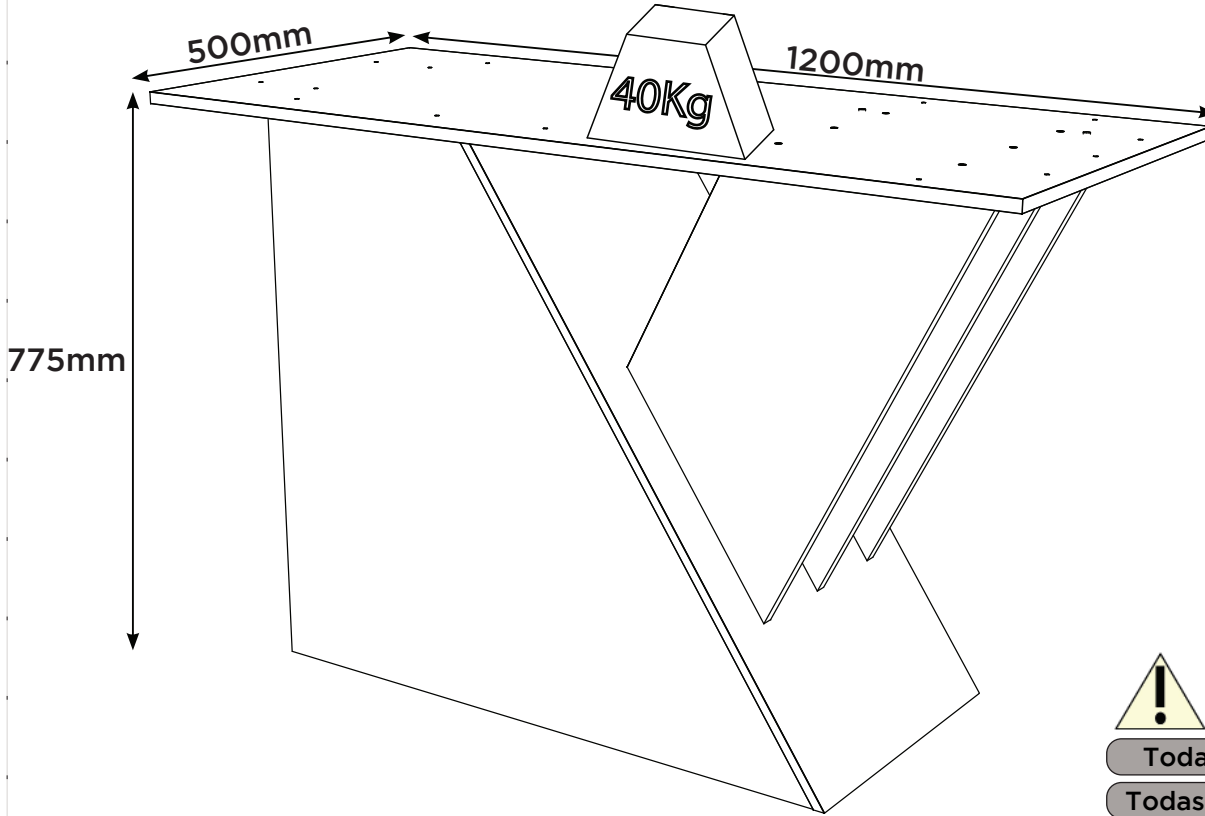

Todas medidas em mm.

Todas las medidas en mm.

All measurements in mm.

Pesos máximos recomendados com carga distribuída
Peso máximo recomendado con la carga distribuida
Recommended maximum weights with evenly distributed.

Requisitos para montagem
Requisitor para la montaje
Assembly Requirements

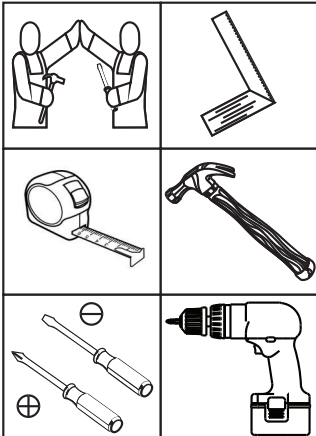

Imagens meramente ilustrativas, não acompanha o produto.
Imágenes ilustrativas, no incluidas con el producto.
Illustrative images, not included with the product.

AVISO

Para limpeza de seu móvel, use uma flanela seca ou umedecida, e não utilize produtos químicos que possam danificar seu produto.

SISTEMA DE MONTAGEM

O sistema de montagem dos produtos, funciona de acordo com a ordem crescente dos números indicados no desenho. Ex: 01, 02, 03, 04... até a conclusão da montagem.

ASSISTÊNCIA TÉCNICA

Para solicitação de Assistência Técnica você consumidor deverá entrar em contato com o Lojista o qual você realizou a compra deste produto e solicitar a assistência técnica das peças avariadas. A garantia abrange todas as peças, partes e componentes que eventualmente venham apresentar defeito de fabricação no prazo de 03 (três) meses, contando a partir da entrega do produto ao consumidor, mediante nota fiscal de compra. Se houver qualquer alteração na estrutura do produto ou ocorrer defeito por negligência do montador/consumidor em relação a instrução de montagem e manuseio, não será fornecido assistência técnica gratuita.

ADVERTENCIA

Para limpieza de su móvil, use una flanela seca o húmeda, y no utilice productos químicos que puedan dañar su producto.

SISTEMA DE MONTAJE

El sistema de montaje de los productos funciona de acuerdo con el orden creciente de los números indicados en el dibujo. Ej.: 01, 02, 03, 04... hasta la conclusión del montaje.

ASISTENCIA TÉCNICA

Para solicitar Asistencia Técnica, el consumidor debe comunicarse con el Comercio que usted realizó la compra de este producto y solicita asistencia técnica para las partes dañadas. La garantía cubre todas las partes, piezas y componentes que eventualmente puedan presentar defecto de fabricación en el plazo de 03 (tres) meses, contados a partir de la entrega del producto al consumidor, mediante factura de compra. Si se produce algún cambio en la estructura del producto o se produce un defecto por negligencia del montador/consumidor en relación con las instrucciones de montaje y manipulación, no se prestará asistencia técnica gratuita.

NOTICE

To clean your furniture, use a dry or wet cloth, and do not use chemicals that may damage your product.

ASSEMBLY SYSTEM

The products' assembly system works according to the increasing order of the indicated numbers. For example: 01, 02, 03, 04 ... to the end of the assembly.

TECHNICAL ASSISTANCE

To request Technical Assistance, the consumer must contact the retailer from whom you purchased this product and request technical assistance for the damaged parts. The warranty covers all parts, parts and components that may eventually present a manufacturing defect within a period of 03 (three) months, counting from the delivery of the product to the consumer, by means of a purchase invoice. If there is any change in the structure of the product or defect occurs due to negligence of the assembler/consumer in relation to the assembly and handling instruction, free technical assistance will not be provided.

1

A = 6

D = 6

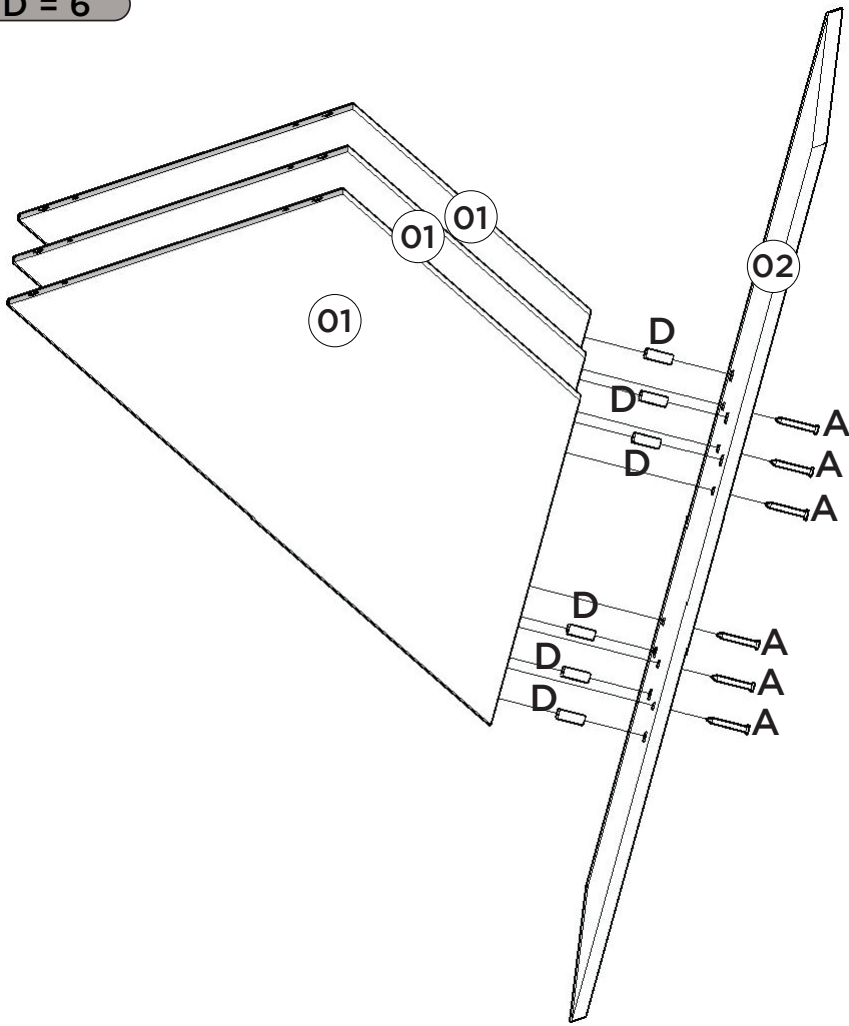

2

C = 24

G = 12

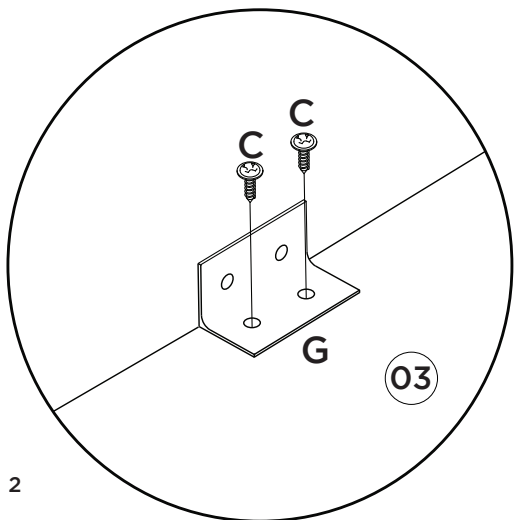
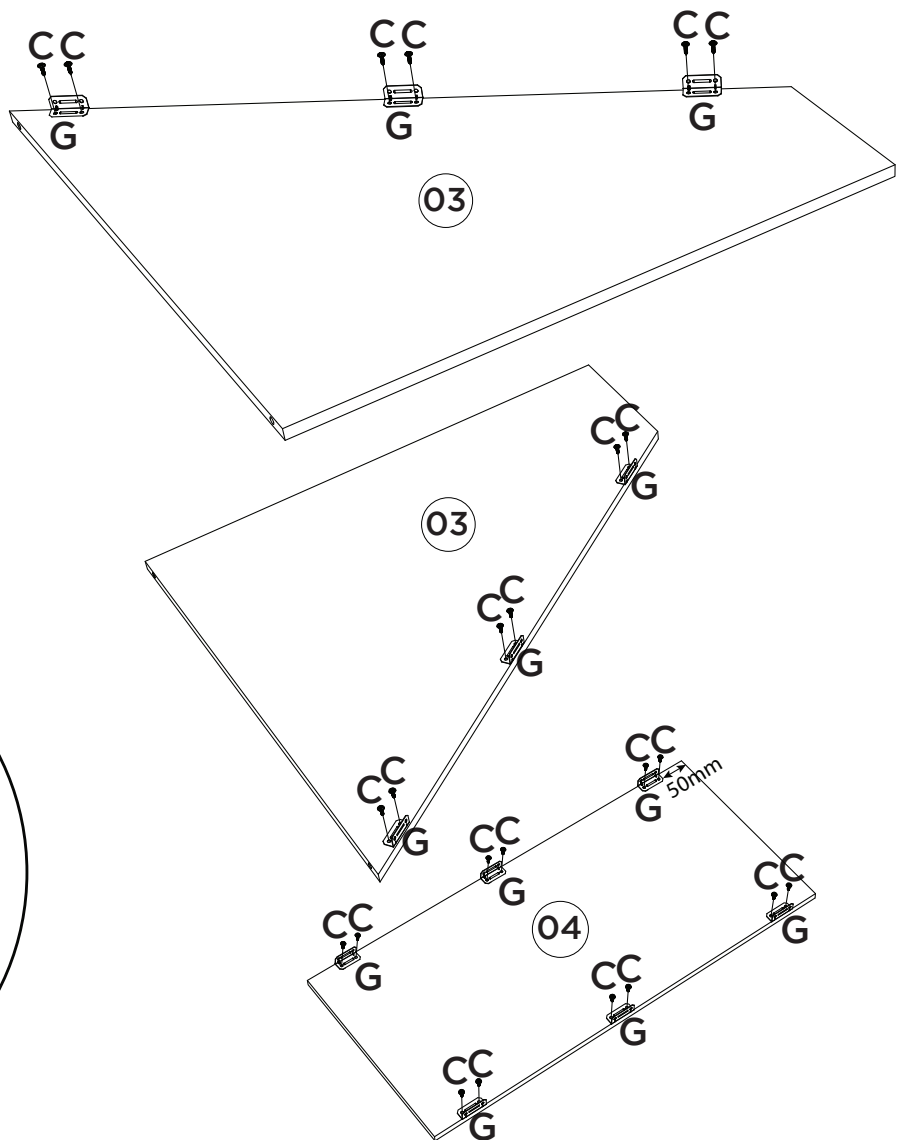

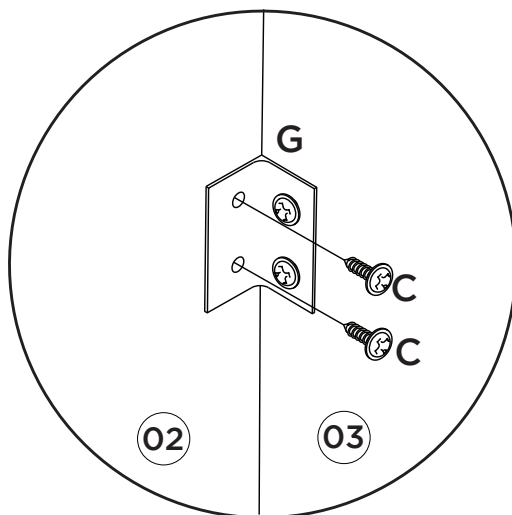
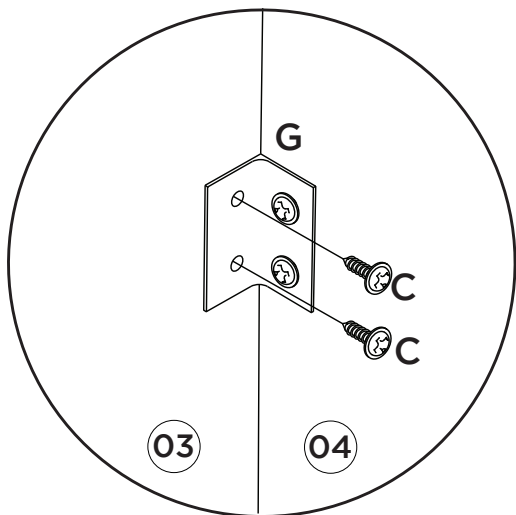
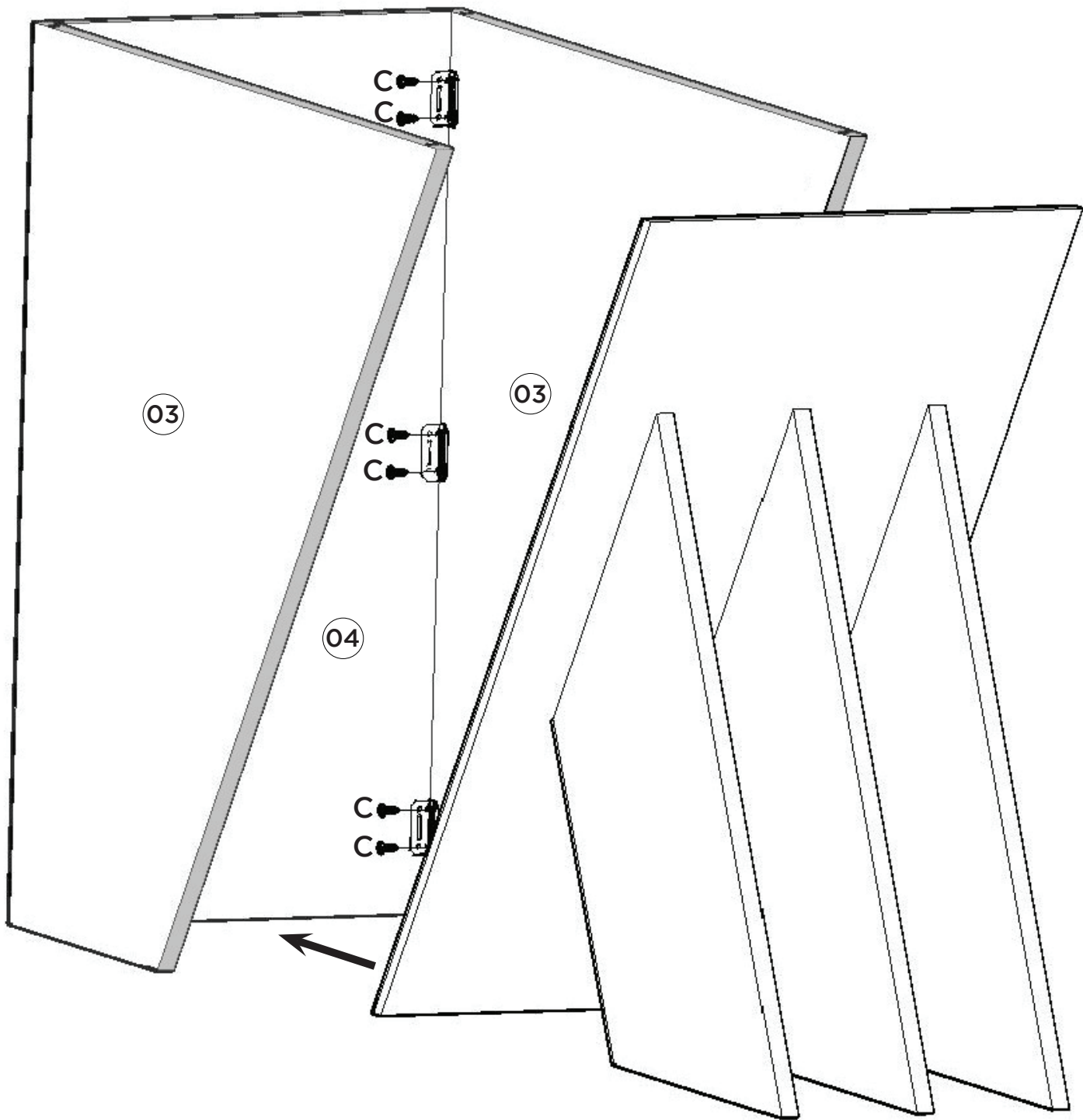

4 E = 04 F = 01

Vista Inferior
 Vista inferior
 Bottom view

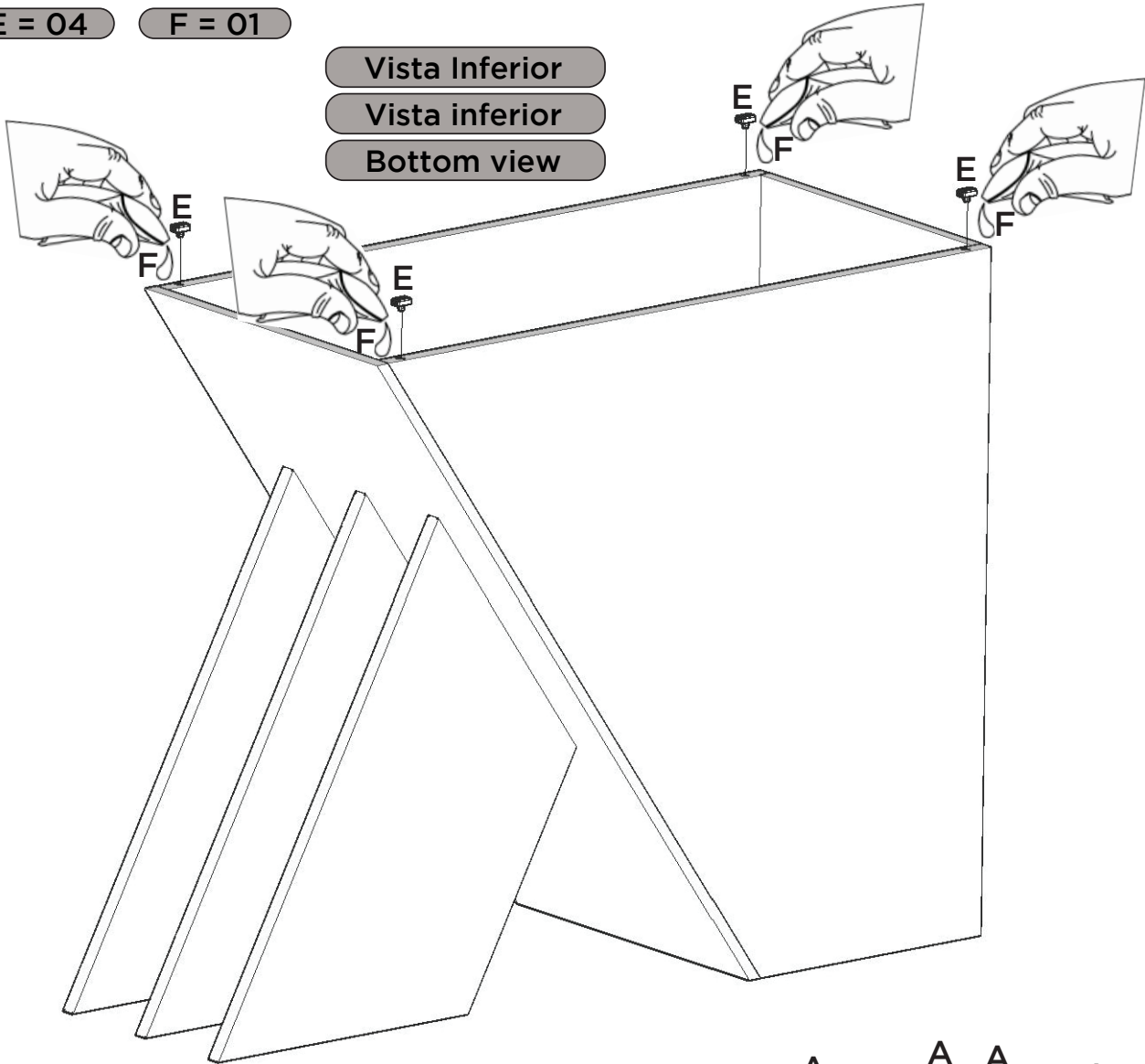

5 A = 12 D = 06 F = 01

Estas furações devem ser utilizadas para alinhamento e fixação do Tampo Estrutural (05).

Estos agujeros deben usarse para alineación y fijación del remate estructural (05).

These holes should be used to align and fixation of the Structural Top (05).

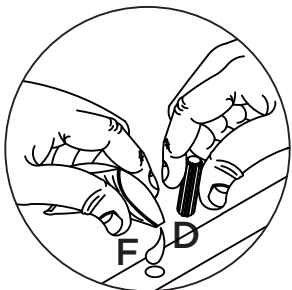
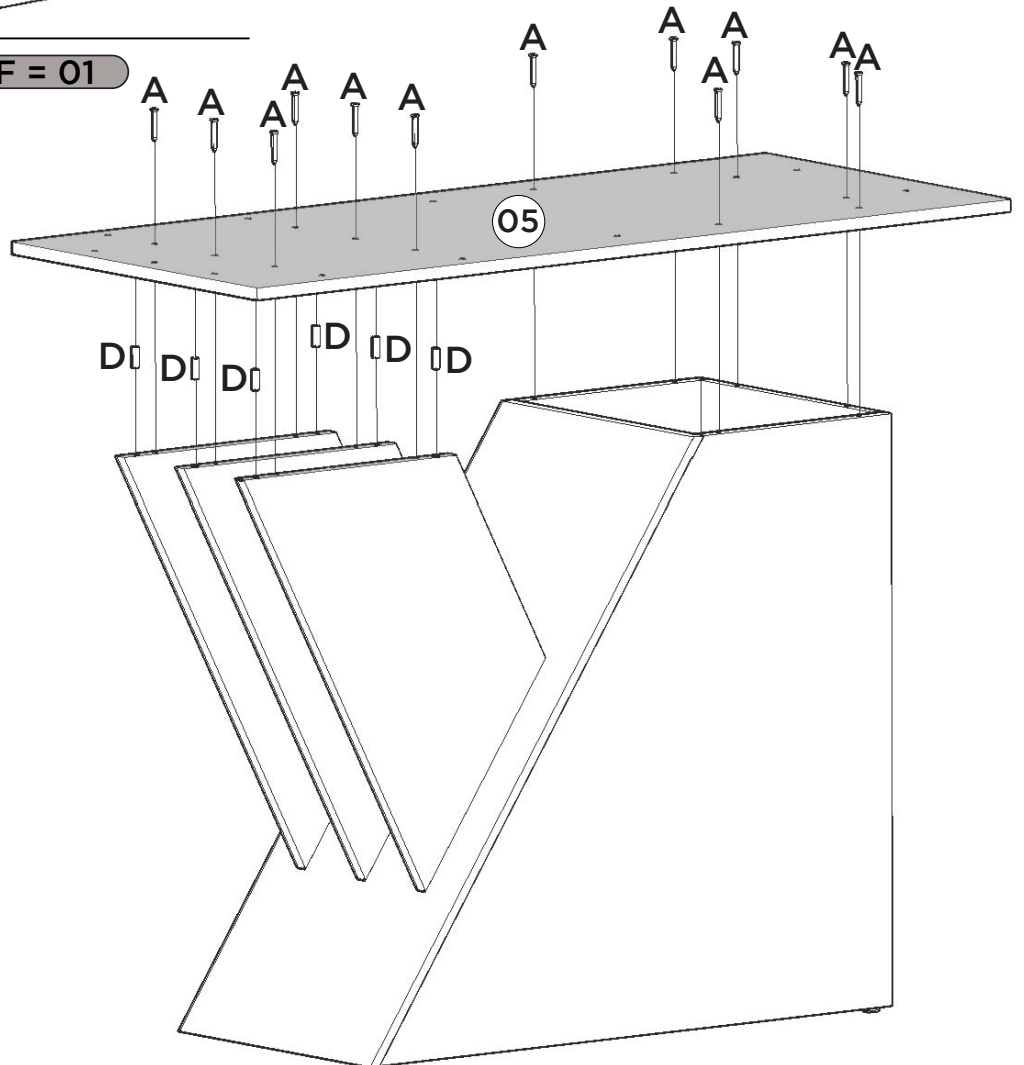

6 B = 11 I = 08



TAMPOS - VENDIDOS SEPARADAMENTE |
TOPS - SE VENDEN POR SEPARADO |
TOPS - SOLD SEPARATELY.

ITM/S412-

Opção de Montagem com o Tampo 2000x900
canto reto com Vidro (S906-139)

Opción de montaje con parte superior 2000x900
esquina recta con vidrio (S906-139)

Mounting Option with Top 2000x900
straight corner with Glass (S906-139)



A pintura do Vidro
deve ficar virada
para baixo, depois
ajustá-lo
sobre os batentes
de silicone (I).

La pintura de
vidrio debe mirar
hacia abajo, luego
ajustarla sobre los
topes de
silicona (I).

The glass paint
should be
facing downwards,
then adjust it over
the silicone stops
(I).

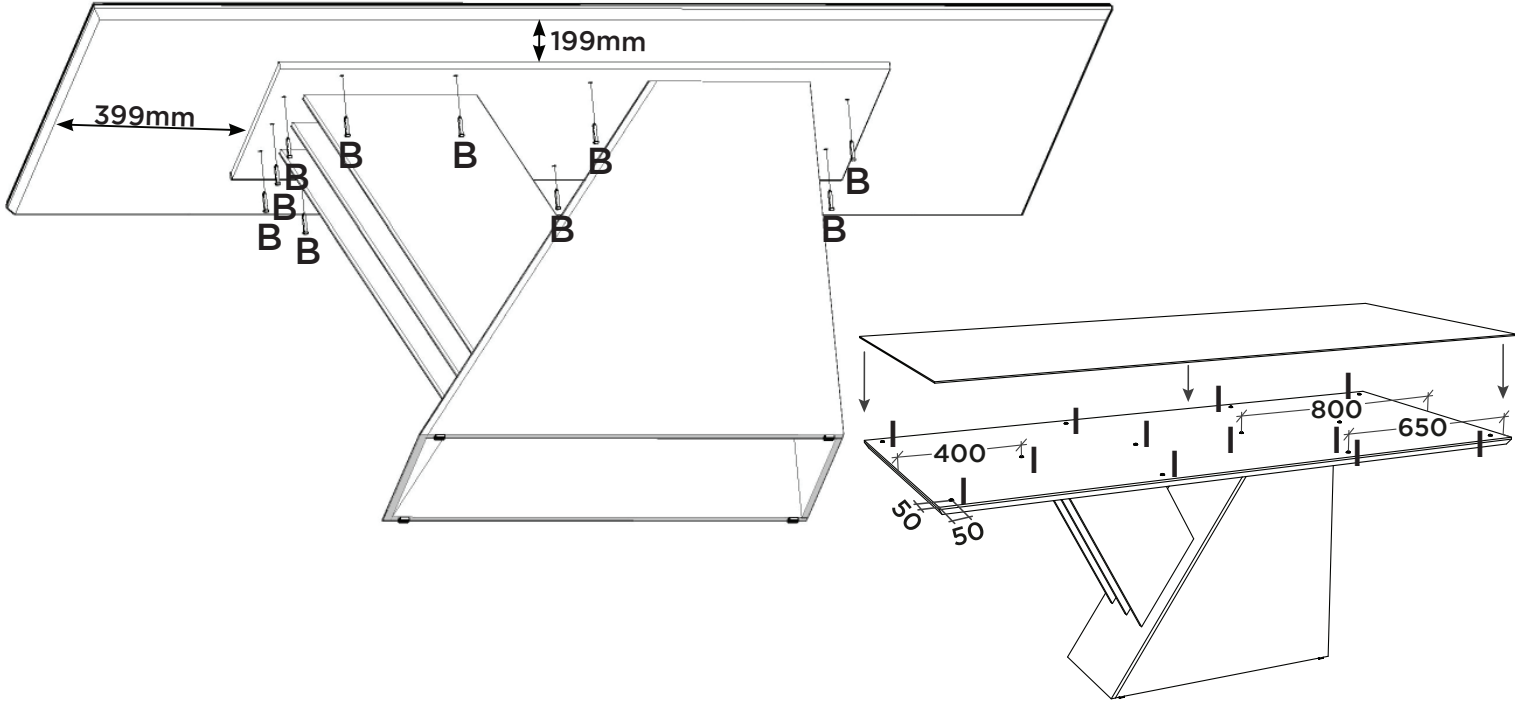

7 B = 11 I = 08

Opção de Montagem com o Tampo 1800x900
canto moeda com Vidro (S922-139)

Opción de montaje con parte superior 1800x900
Esquina de monedas con vidrio (S922-139)

Mounting Option with Top 1800x900
Coin corner with Glass (S922-139)

ITM/S412-

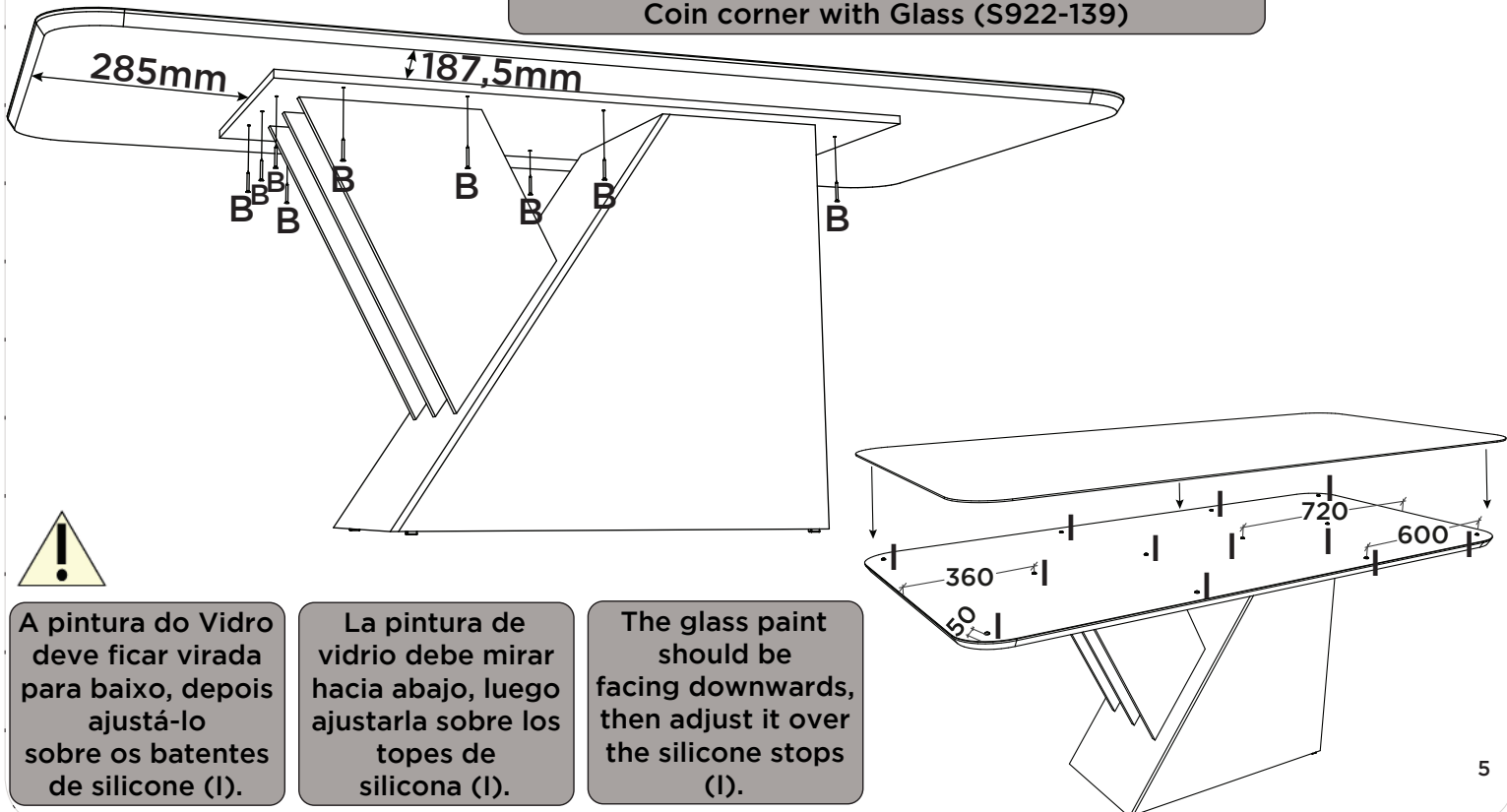

A pintura do Vidro
deve ficar virada
para baixo, depois
ajustá-lo
sobre os batentes
de silicone (I).

La pintura de
vidrio debe mirar
hacia abajo, luego
ajustarla sobre los
topes de
silicona (I).

The glass paint
should be
facing downwards,
then adjust it over
the silicone stops
(I).

8 B = 11 I = 08

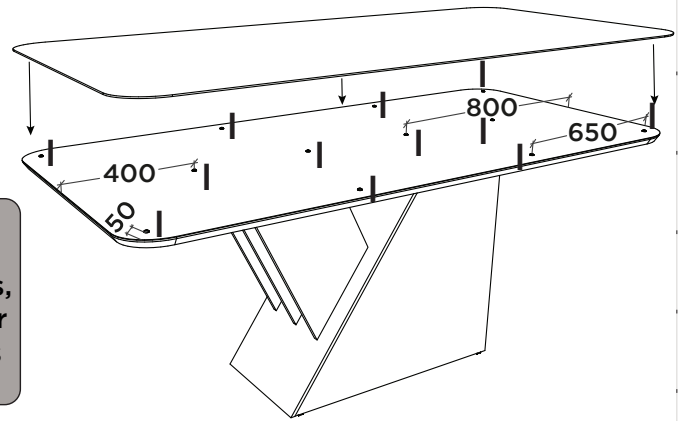
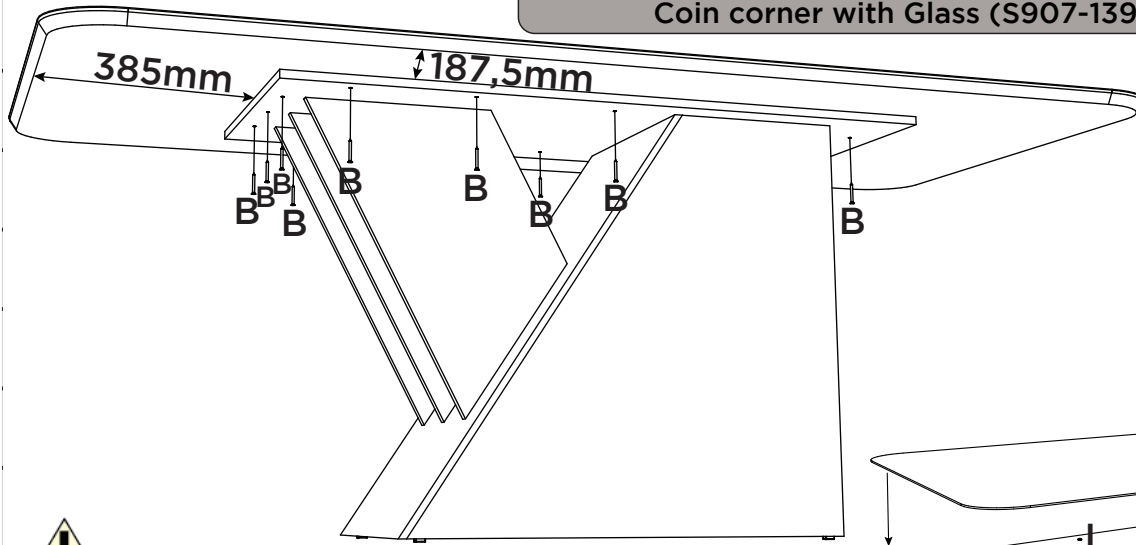
Opção de Montagem com o Tampo 2000x900
canto moeda com Vidro (S907-139)Opción de montaje con parte superior 2000x900
Esquina de monedas con vidrio (S907-139)Mounting Option with Top 2000x900
Coin corner with Glass (S907-139)

A pintura do Vidro
deve ficar virada
para baixo, depois
ajustá-lo
sobre os batentes
de silicone (I).

La pintura de
vidrio debe mirar
hacia abajo, luego
ajustarla sobre los
topes de
silicona (I).

The glass paint
should be
facing downwards,
then adjust it over
the silicone stops
(I).

9 B = 11 I = 06

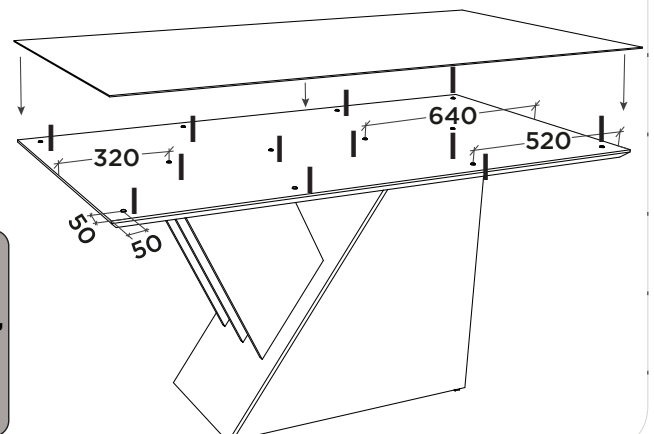
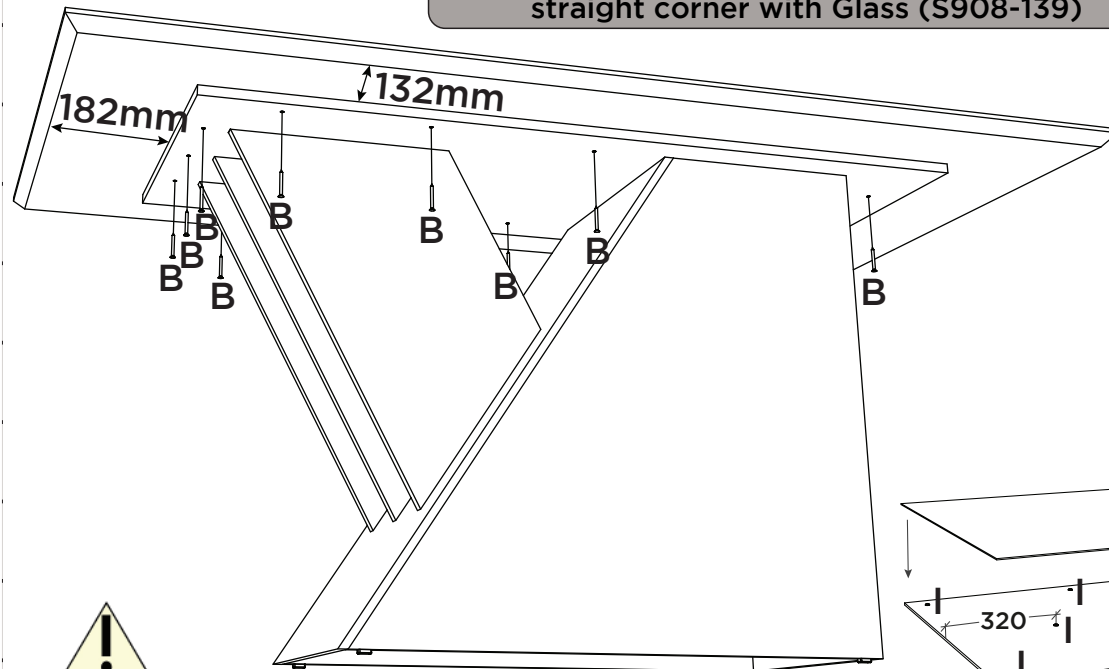
Opção de Montagem com o Tampo 1600x900
canto reto com Vidro (S908-139)Opción de montaje con parte superior 1600x900
esquina recta con vidrio (S908-139)Mounting Option with Top 1600x900
straight corner with Glass (S908-139)

A pintura do Vidro
deve ficar virada
para baixo, depois
ajustá-lo
sobre os batentes
de silicone (I).

La pintura de
vidrio debe mirar
hacia abajo, luego
ajustarla sobre los
topes de
silicona (I).

The glass paint
should be
facing downwards,
then adjust it over
the silicone stops
(I).

10 B = 11 I = 06

Opção de Montagem com o Tampo 1600x900
canto moeda com Vidro (S909-139)

Opción de montaje con parte superior 1600x900
Esquina de monedas con vidrio (S909-139)

Mounting Option with Top 1600x900
Coin corner with Glass (S909-139)

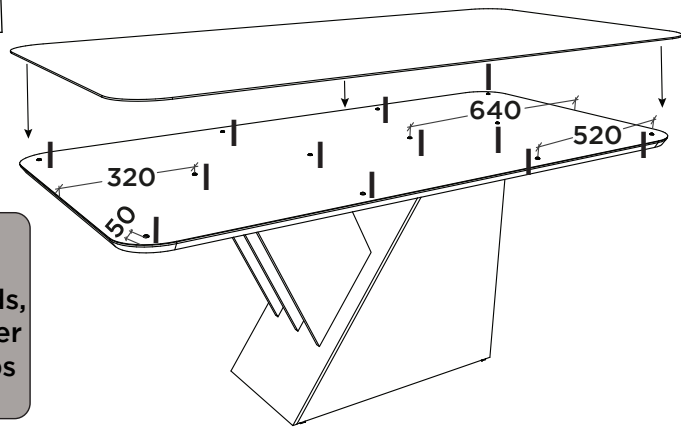
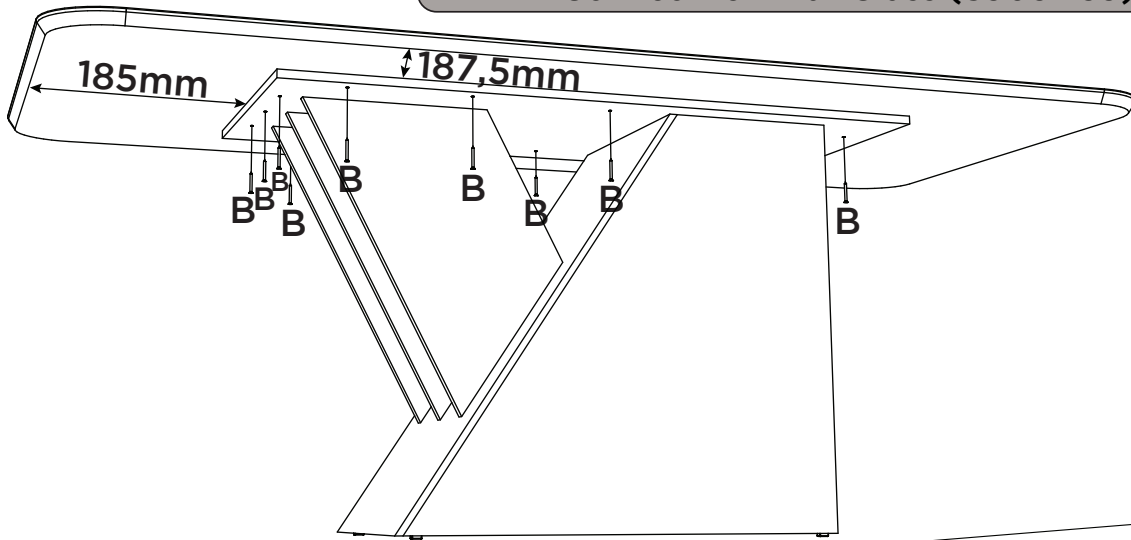

A pintura do Vidro
deve ficar virada
para baixo, depois
ajustá-lo
sobre os batentes
de silicone (I).

La pintura de
vidrio debe mirar
hacia abajo, luego
ajustarla sobre los
topes de
silicona (I).

The glass paint
should be
facing downwards,
then adjust it over
the silicone stops
(I).

11 B = 11

Opção de Montagem com o Tampo 1600x900
canto reto sem Vidro (S910-139)

Opción de montaje con parte superior 1600x900
esquina recta sin vidrio (S910-139)

Mounting Option with Top 1600x900
straight corner without Glass (S910-139)

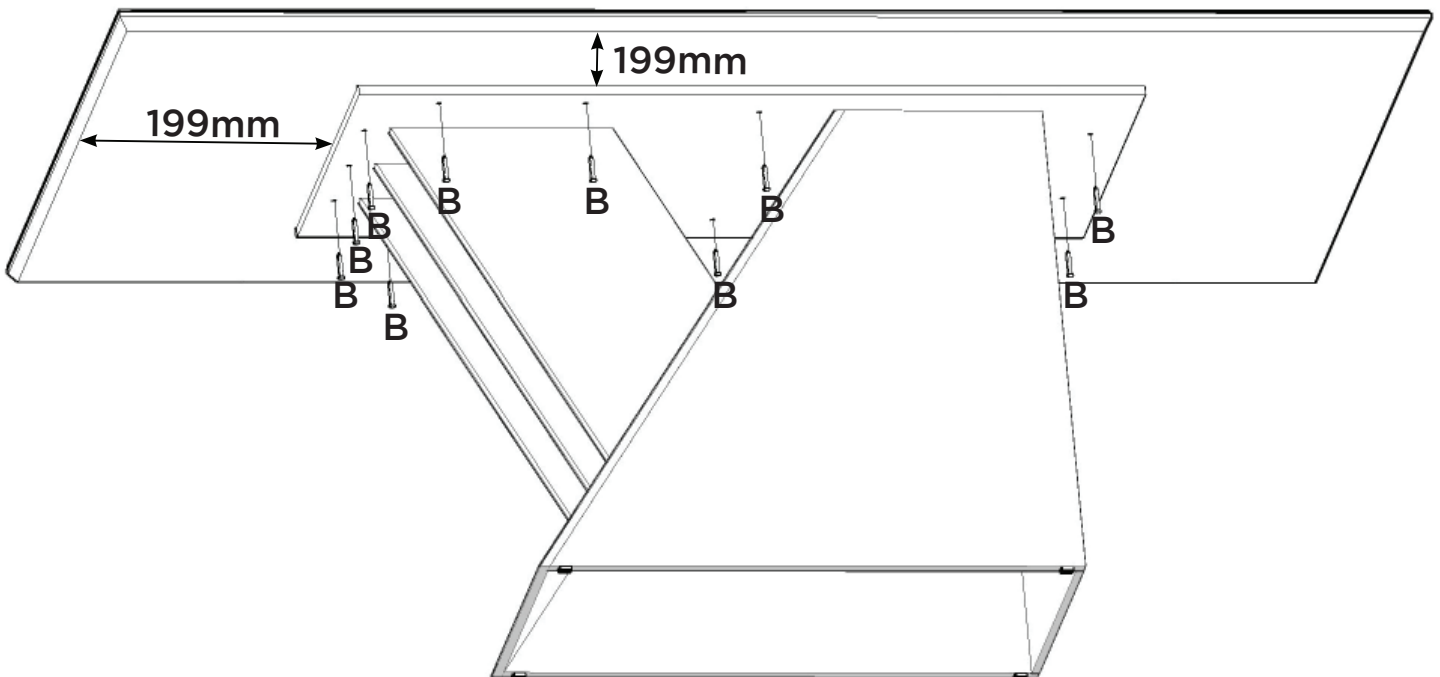





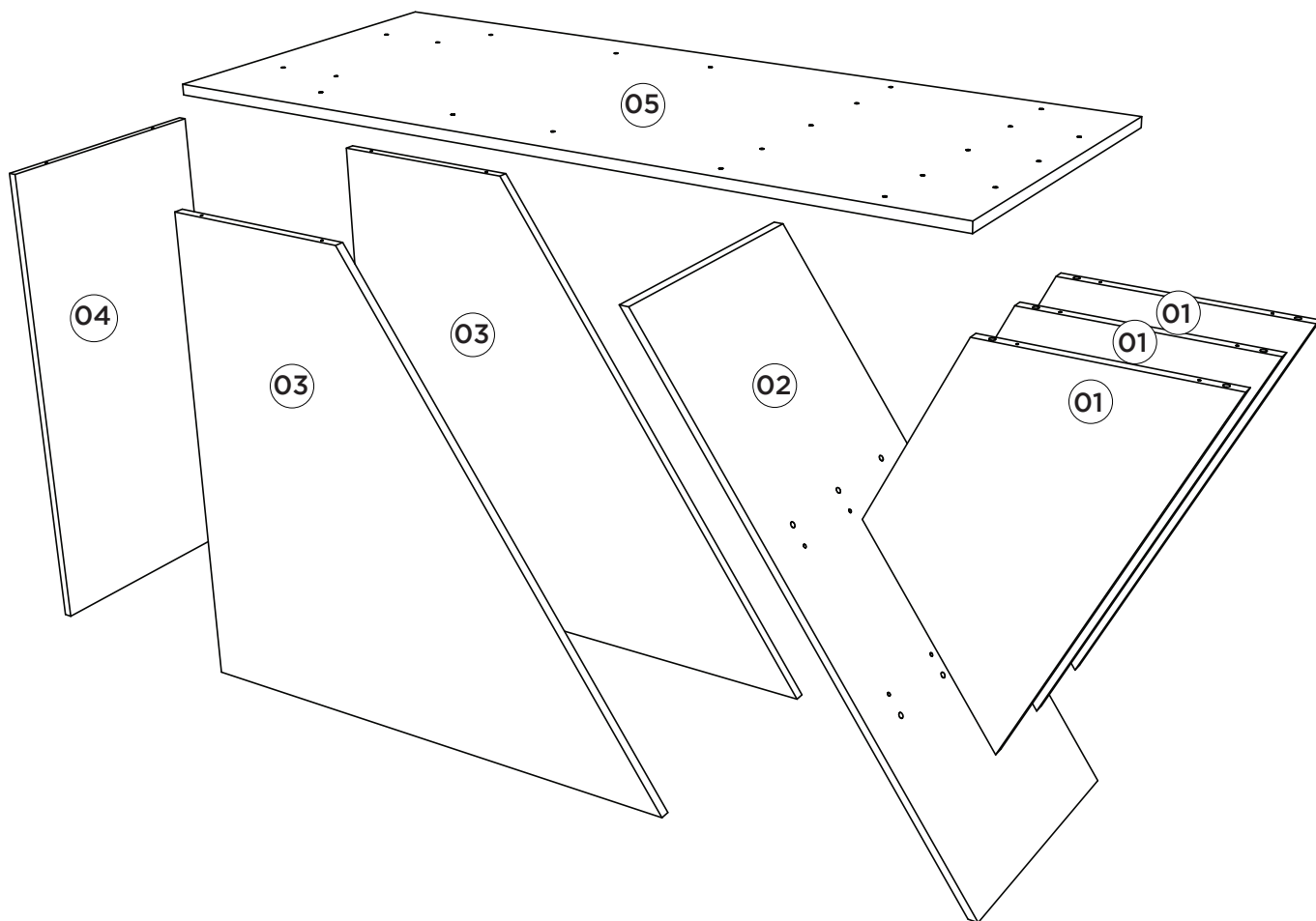

Lista de Peças | Lista de piezas | List of parts

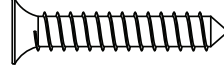
Item	Caixa Caja Box	Qtd Ctd Qty	Descrição Descripción Description	Medidas (mm) Dimensions (mm) Size (measurements) (mm)
01	1/1	03	Painel Menor Panel Más Pequeno Smaller Panel	620x300x15
02	1/1	01	Lateral Chanfrada Lado Biselado Larger Side	920x390x12
03	1/1	02	Lateral Maior Lado Más Grande Right panel	751x817x15
04	1/1	01	Lateral Menor Lado Más Pequeno Minor Side	751x358x12
05	1/1	01	Tampo Estrutural Superfície estrutural Structural Top	1200x500x15

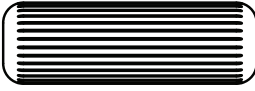

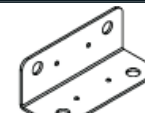
Ferragens | Herrajes | Hardware

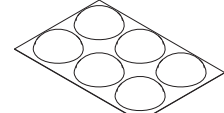
A	18x	B	11x	C	48x	D	12x
							
Parafuso 3,5x40mm CHT. Tornillo 3,5x40mm CHT. Screw 3,5x40mm CHT.		Parafuso 4,0x25mm CHT. Tornillo 4,0x25mm CHT. Screw 4,0x25mm CHT.		Parafuso 3,5x12mm FLA. Tornillo 3,5x12mm FLA. Screw 3,5x12mm FLA.		Cavilha 8x25mm Cinta 8x25mm Dowel 8x25mm	
E	04x	F	01x	G	12x	H	02x
							
Sapata Deslizante 15x26x8mm Zapato deslizante 15x26x8mm Sliding Shoe 15x26x8mm		Sachê de cola Bolsa de pegamento Glue bag		Cantoneira 17,5x17,5x44 Cantonera 17,5x17,5x44 Angle 17,5x17,5x44		Giz de correção Tiza de corrección Chalk of correction	
I	02x						
							
Kit Batente silicone (6 unidades) tapón de silicona Kit (6 unidades) Kit silicone stopper (6 units)							

HENN

Ind. e Com. de Móveis Henn
Mondai - SC - Brasil

+55 49 3674.3500

@moveishenn
www.henn.com.br

INSTRUÇÕES DE MONTAGEM

INSTRUCCIONES DE MONTAJE
ASSEMBLY INSTRUCTIONS

ITM/S34-

CADEIRA ELOÁ

S34-502 Nature/Linho

S34-510 Nature/Marrom Amêndoa

S34-511 Nature/Marrom Expresso

S34-538 Nature/Creme

S34-539 Nature/Cacao

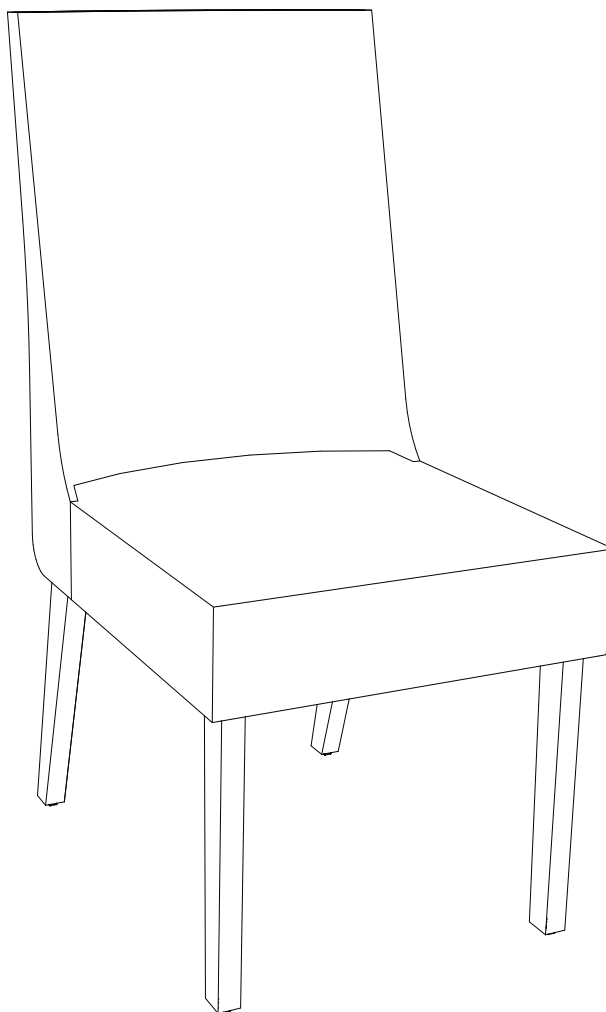

Requisitos para montagem Requisitor para la montaje Assembly Requirements

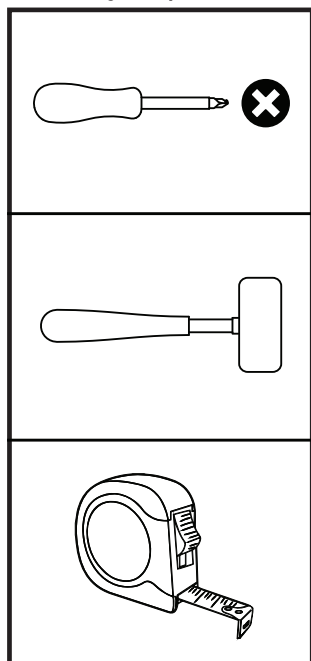

Imagens meramente ilustrativas,
não acompanha o produto.
Imágenes ilustrativas, no incluidas
con el producto.
Illustrative images, not included
with the product.

AVISO

Para limpeza de seu móvel, use uma flanela seca ou umedecida, e não utilize produtos químicos que possam danificar seu produto.

SISTEMA DE MONTAGEM

O sistema de montagem dos produtos, funciona de acordo com a ordem crescente dos números indicados no desenho. Ex: 01, 02, 03, 04... até a conclusão da montagem.

ASSISTÊNCIA TÉCNICA

Para solicitação de Assistência Técnica você consumidor deverá entrar em contato com o Lojista o qual você realizou a compra deste produto e solicitar a assistência técnica das peças avariadas. A garantia abrange todas as peças, partes e componentes que eventualmente venham apresentar defeito de fabricação no prazo de 03 (três) meses, contando a partir da entrega do produto ao consumidor, mediante nota fiscal de compra. Se houver qualquer alteração na estrutura do produto ou ocorrer defeito por negligência do montador/consumidor em relação a instrução de montagem e manuseio, não será fornecido assistência técnica gratuita.

ADVERTENCIA

Para limpieza de su móvil, use una flanela seca o húmeda, y no utilice productos químicos que puedan dañar su producto.

SISTEMA DE MONTAJE

El sistema de montaje de los productos funciona de acuerdo con el orden creciente de los números indicados en el dibujo. Ej.: 01, 02, 03, 04... hasta la conclusión del montaje.

ASISTENCIA TÉCNICA

Para solicitar Asistencia Técnica, el consumidor debe comunicarse con el Comercio que usted realizó la compra de este producto y solicita asistencia técnica para las partes dañadas. La garantía cubre todas las partes, piezas y componentes que eventualmente puedan presentar defecto de fabricación en el plazo de 03 (tres) meses, contados a partir de la entrega del producto al consumidor, mediante factura de compra. Si se produce algún cambio en la estructura del producto o se produce un defecto por negligencia del montador/consumidor en relación con las instrucciones de montaje y manipulación, no se prestará asistencia técnica gratuita.

NOTICE

To clean your furniture, use a dry or wet cloth, and do not use chemicals that may damage your product.

ASSEMBLY SYSTEM

The products' assembly system works according to the increasing order of the indicated numbers. For example: 01, 02, 03, 04 ... to the end of the assembly.

TECHNICAL ASSISTANCE





To request Technical Assistance, the consumer must contact the retailer from whom you purchased this product and request technical assistance for the damaged parts. The warranty covers all parts, parts and components that may eventually present a manufacturing defect within a period of 03 (three) months, counting from the delivery of the product to the consumer, by means of a purchase invoice. If there is any change in the structure of the product or defect occurs due to negligence of the assembler/consumer in relation to the assembly and handling instruction, free technical assistance will not be provided.

1 Pré Montagem Preasamblea | Pre-assembly

Peças Necessárias | Partes requeridas | Required Parts:

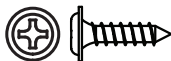
3	Pé Frontal Pie delantero Front foot	04
4	Pé Traseiro Pie trasero Back foot	04
5	Travessa Lateral Plato lateral Side Platter	04
6	Travessa Plato Platter	04

Ferragens | Herrajes | Hardware:

D		x24
F		x08
G		x16
I		
K		

Ferramentas | Instrumentos | Tools:

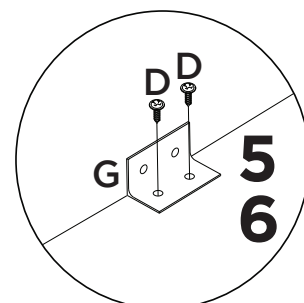
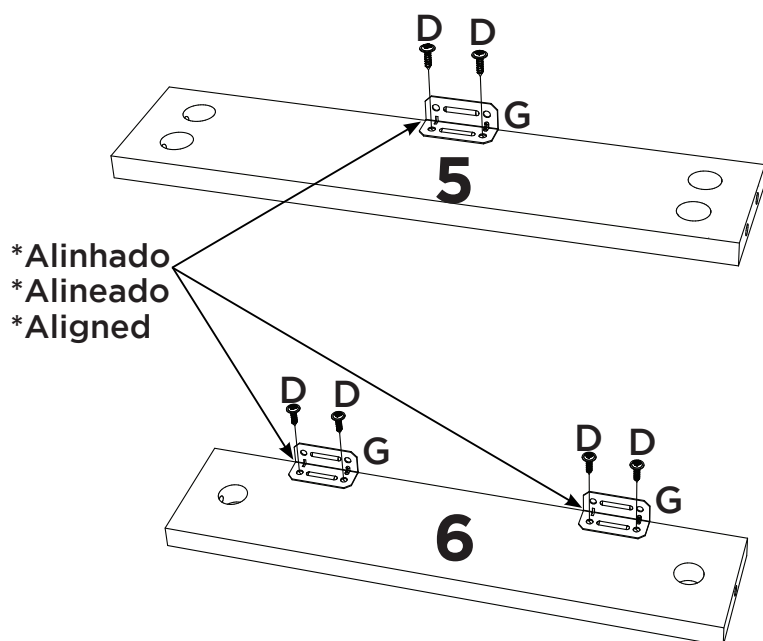
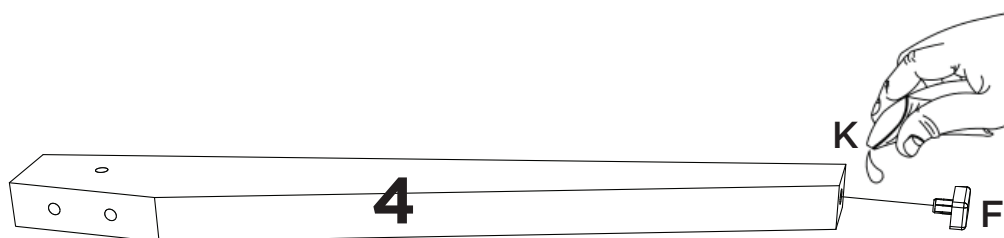
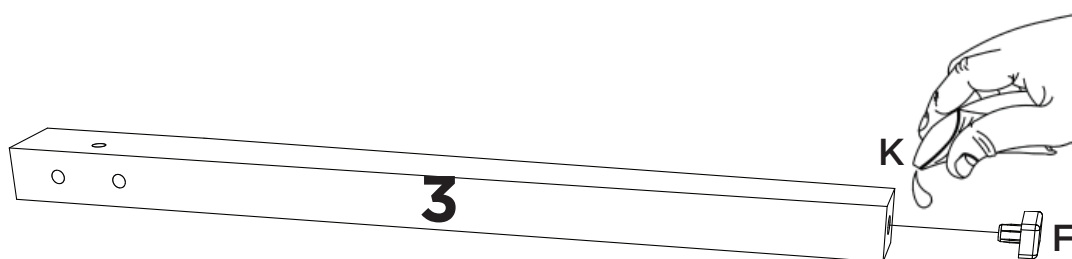
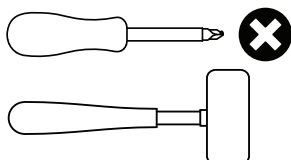



3

Peças Necessárias | Partes requeridas | Required Parts:

3	Pé Frontal Pie delantero Front foot	04
4	Pé Traseiro Pie trasero Back foot	04
5	Travessa Lateral Plato lateral Side Platter	04

Ferragens | Herrajes | Hardware:

A		x16
E		x16
I		

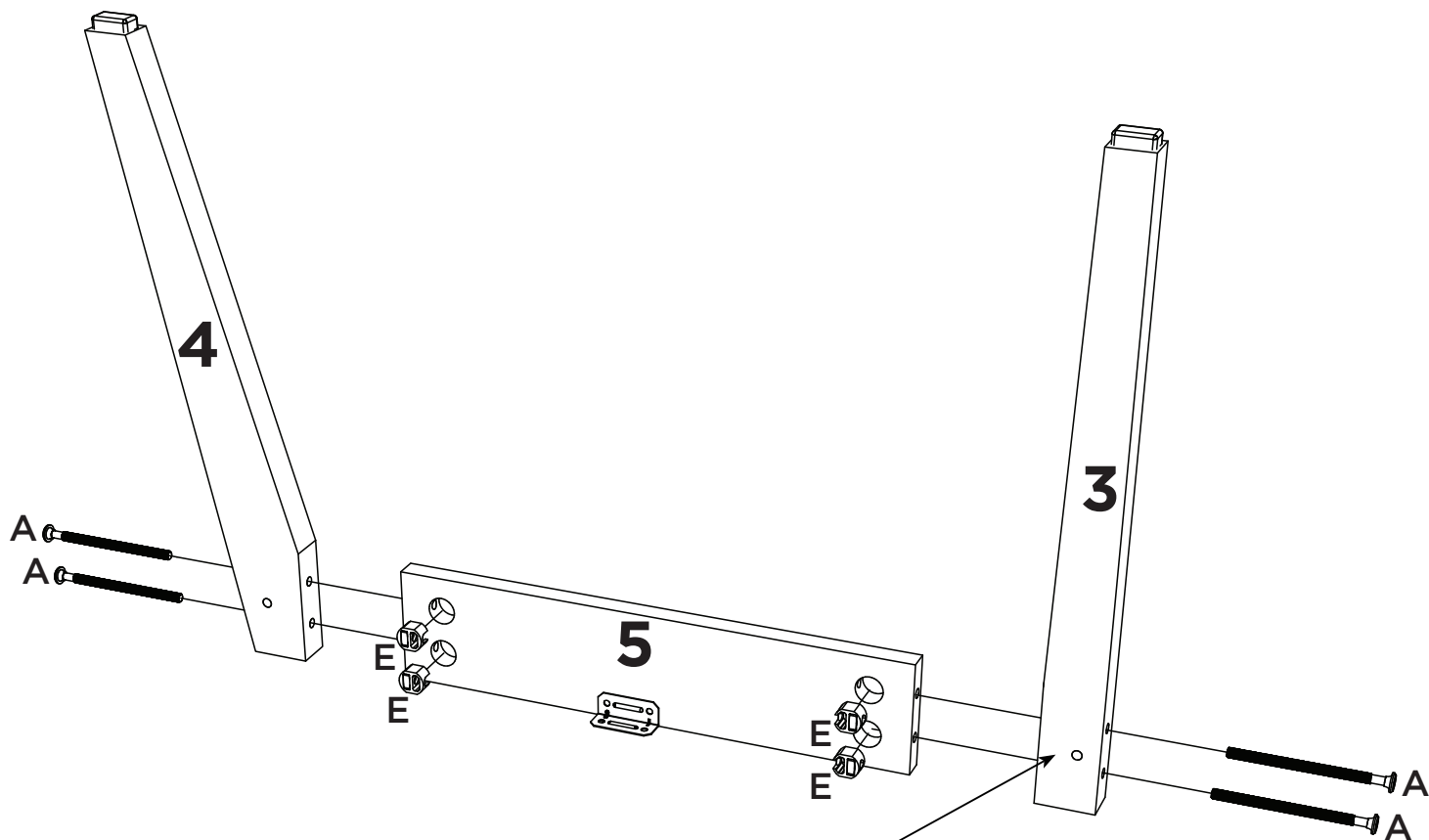

*Furação próxima a borda de fora do Pé.

*Perforar cerca del borde exterior del pie.

*Drilling close to the outside edge of the Foot.

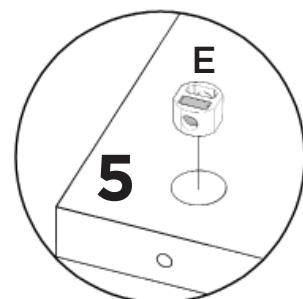
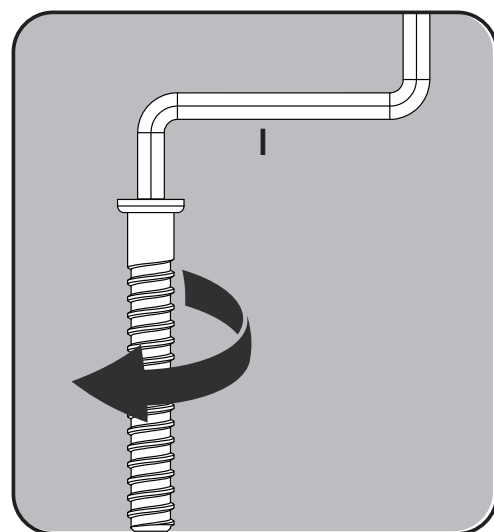
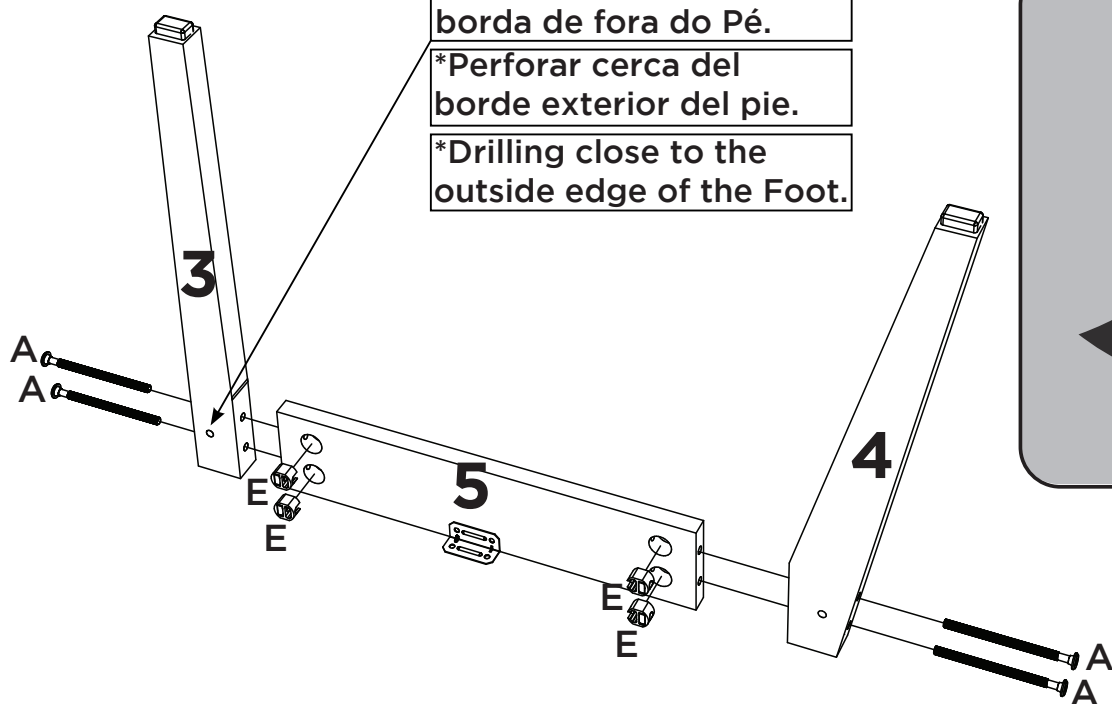



4

Peças Necessárias | Partes requeridas | Required Parts:

6	Travessa Plato Platter	04
---	----------------------------	----

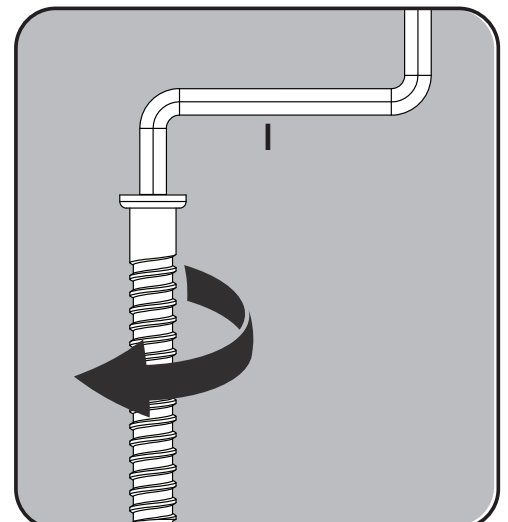
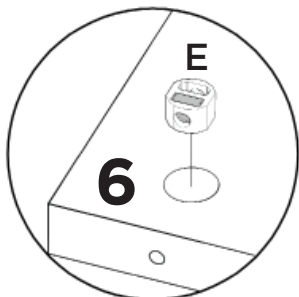
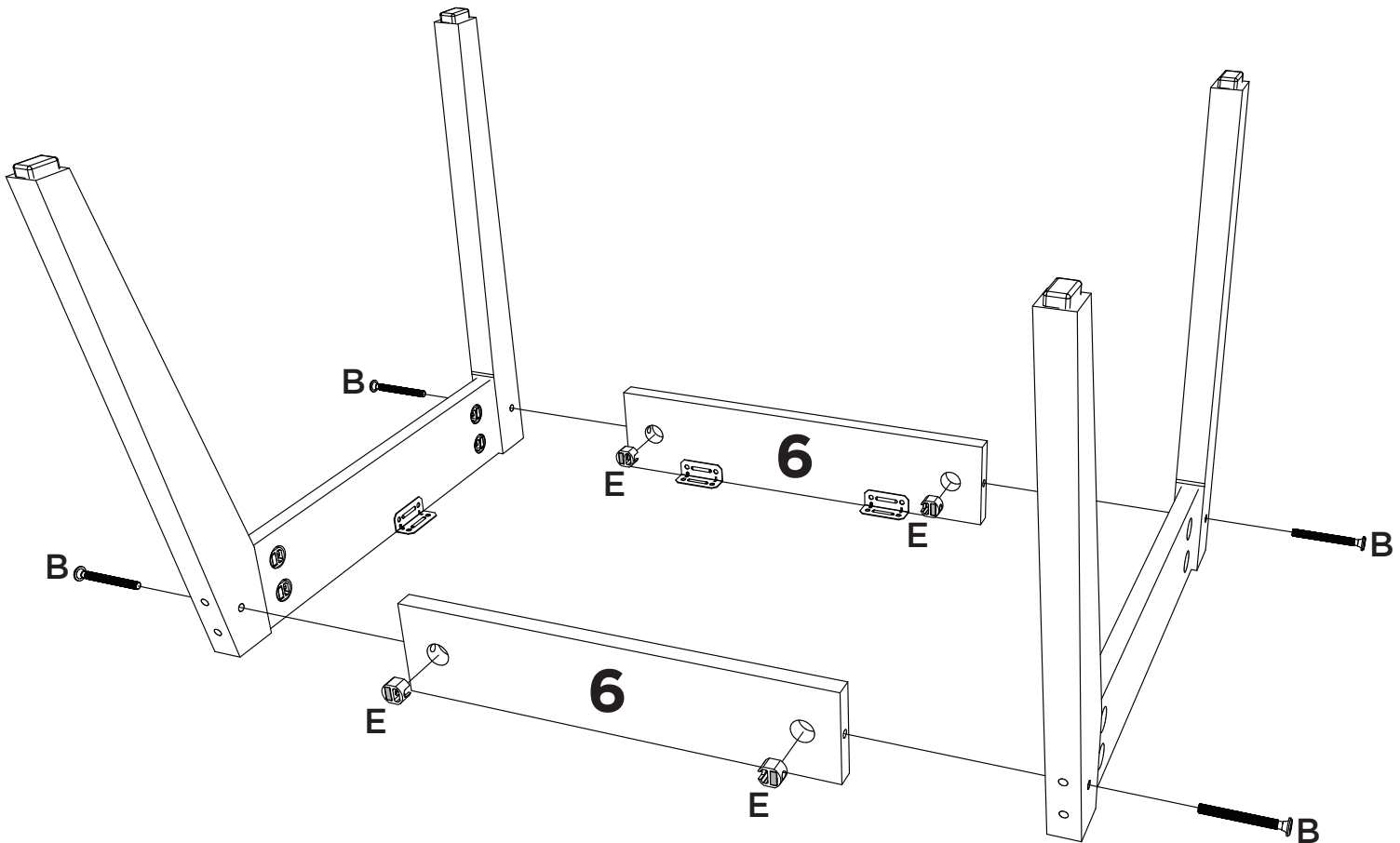

Ferragens | Herrajes | Hardware:

B		x08
E		x08
I		



5

Ferragens | Herrajes | Hardware:

D		x40
J		x08

Ferramentas | Instrumentos | Tools:

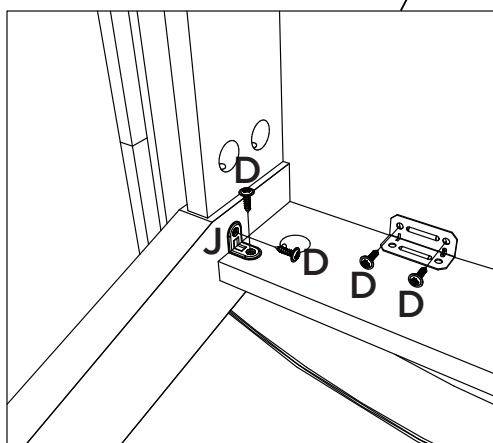
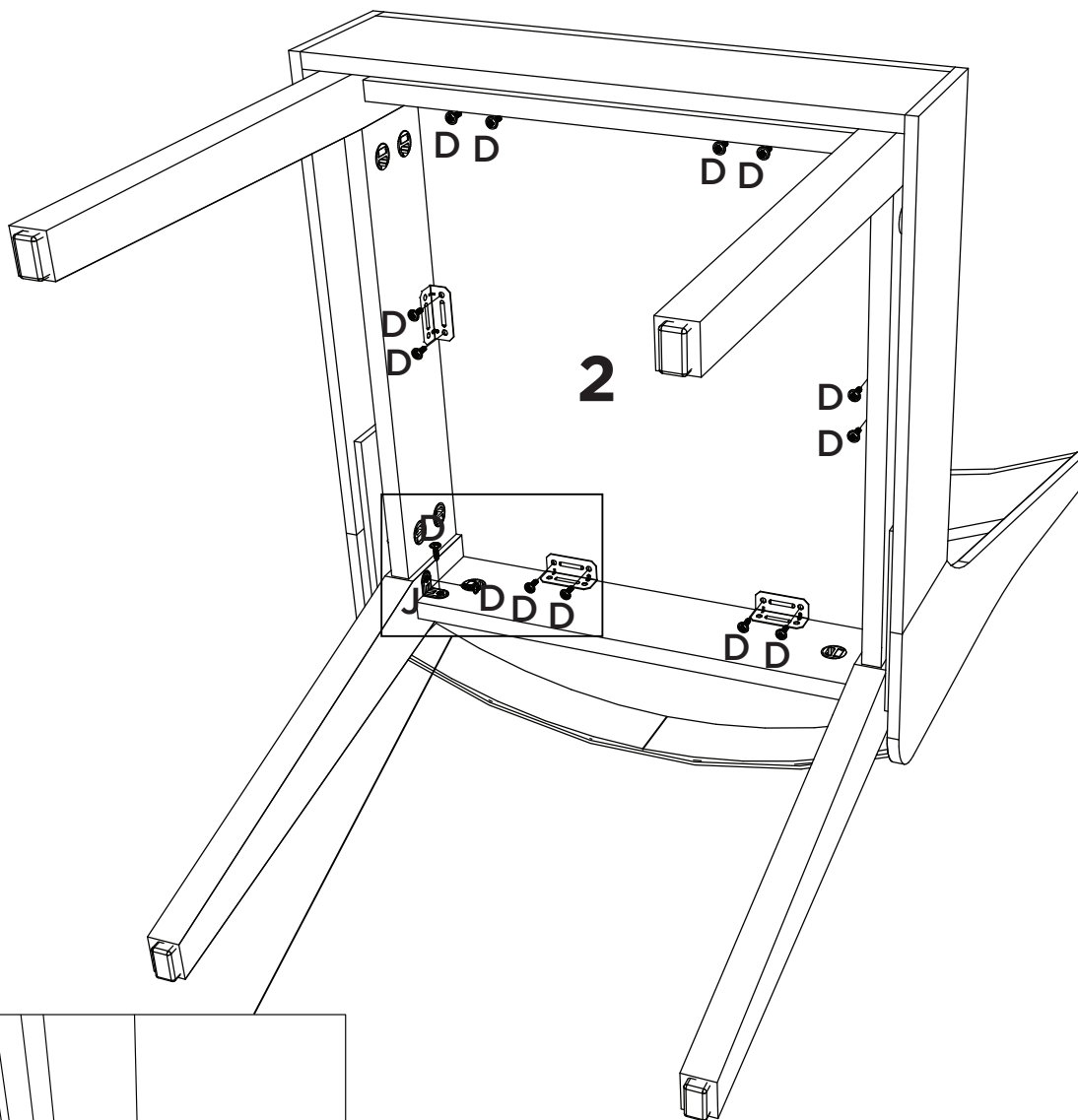
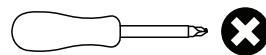

*Cantoneira de metal (J) nos quatro cantos da cadeira, o mais próximo possível da borda inferior.

*Soporte angular de metal (J) en los cuatro esquinas de la silla, las más cercanas posible desde el borde inferior.

*Metal angle bracket (J) on all four corners of the chair, the closest possible from the bottom edge.

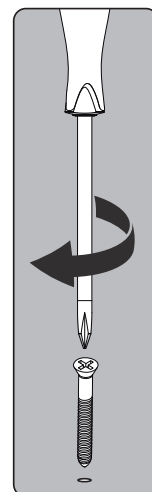
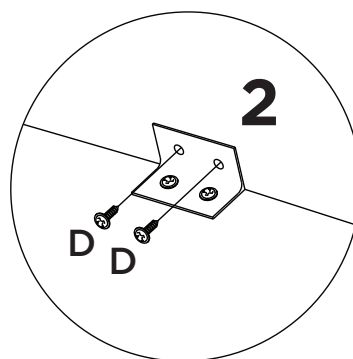

6

Ferragens | Herrajes | Hardware:

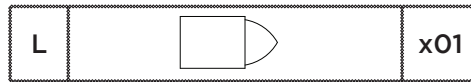

Pesos máximos recomendados com carga distribuída
 Peso máximo recomendado con la carga distribuida
 Recommended maximum weights with evenly distributed.

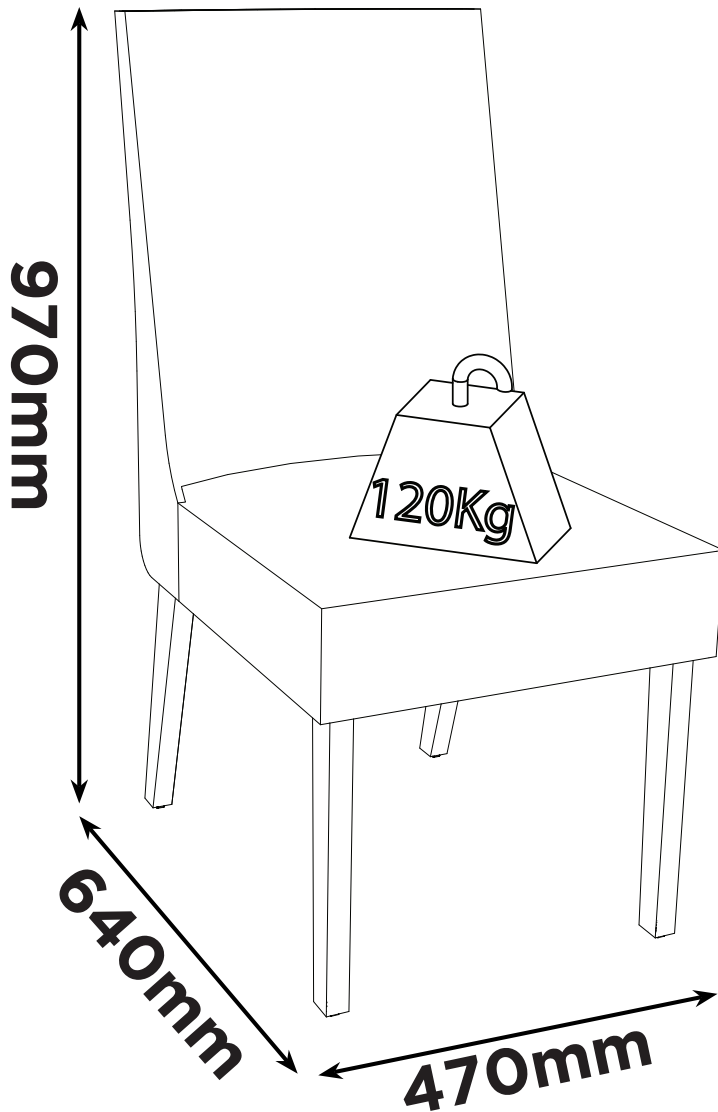

PERFECT CORRECTION
 CORRECCIÓN PERFECTA

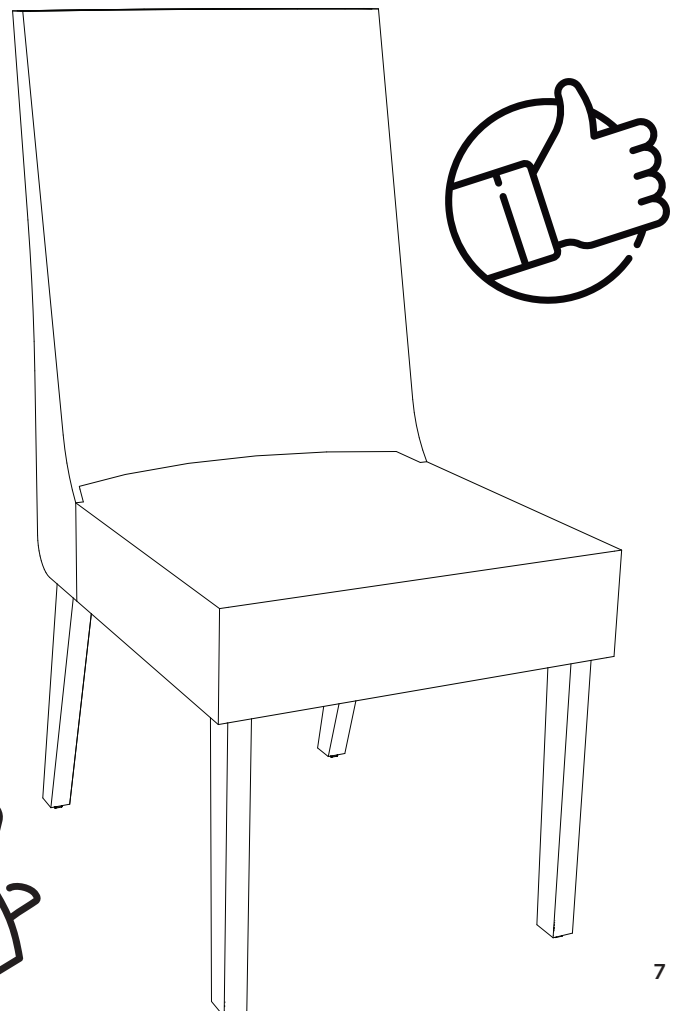
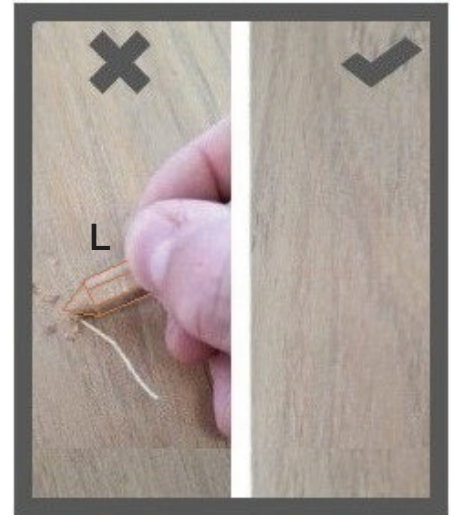





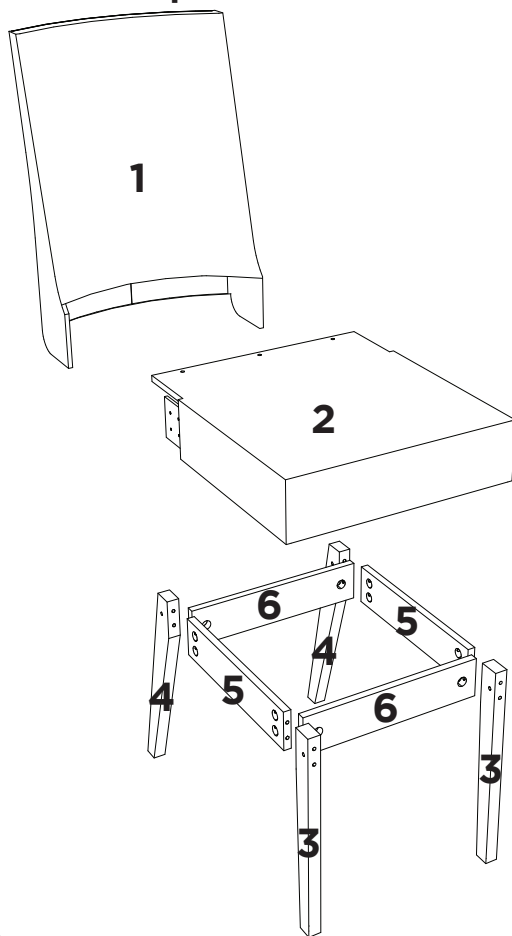

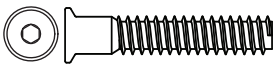

Item	Caixa Caja Box	Qtd Ctd Qty	Descrição Descripción Description	Medidas (mm) Dimensions (mm) Size (measurements) (mm)
01	1/1	02	Encosto Estofado Respaldo tapizado Upholstered backrest	665x460x185
02	1/1	02	Assento Estofado Asiento tapizado Upholstered seat	510x460x155
03	1/1	04	Pé Frontal Pie delantero Front foot	425x40x25
04	1/1	04	Pé Traseiro Pie trasero Back foot	425x130x25
05	1/1	04	Travessa Lateral Plato lateral Side Platter	366x80x15
06	1/1	04	Travessa Plato Platter	366x80x15

O volume contém peças para montagem de 2 Cadeiras.
El volumen contiene piezas para montar 2 sillas.
The volume contains parts for mounting 2 Chairs.

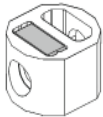
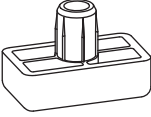
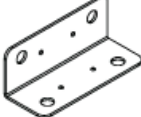

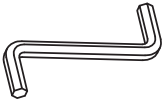
Ferragens | Herrajes | Hardware

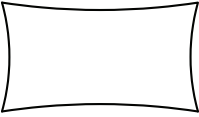
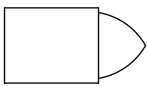
<p>A 16x</p>  <p>Parafuso Cab PL 17 Allen 4.14x3,12 (80mm) Tornillo PL 17 Allen 4.14x3.12 (80mm) Screw PL 17 Allen 4.14x3.12 (80mm)</p>	<p>B 08x</p>  <p>Parafuso Cab PL 17 Allen 4.14x3,12 (60mm) Tornillo PL 17 Allen 4.14x3.12 (60mm) Screw PL 17 Allen 4.14x3.12 (60mm)</p>	<p>C 06x</p>  <p>Parafuso 7,0x40mm CHT Allen Tornillo Allen CHT de 7,0x40 mm Screw 7.0x40mm CHT Allen</p>	<p>D 64x</p>  <p>Parafuso 3,5x14mm FLA Tornillo 3,5x14mm FLA Screw 3,5x14mm FLA</p>
<p>E 24x</p>  <p>Porca meia lua plástica rosca 1/4 1/4 tuerca de media luna de plástico 1/4 plastic half moon nut</p>	<p>F 08x</p>  <p>Sapata Deslizante 15x26x8mm Zapato deslizante 15x26x8mm Sliding Shoe 15x26x8mm</p>	<p>G 12x</p>  <p>Cantoneira 17,5x17,5x44 Cantonera 17,5x17,5x44 Angle 17,5x17,5x44</p>	<p>H 16x</p>  <p>Parafuso 3,0x16mm CHT Tornillo 3,0x16mm CHT Screw 3,0x16mm CHT</p>
<p>I 01x</p>  <p>Chave Allen llave Allen Allen key</p>	<p>J 08x</p>  <p>Cantoneira metal 18x18 Cantonera metálica 18x18 18x18 metal angle bracket</p>	<p>K 01x</p>  <p>Sachê de cola Bolsa de pegamento Glue bag</p>	<p>L 01x</p>  <p>Giz de correção Tiza de corrección Chalk of correction</p>