

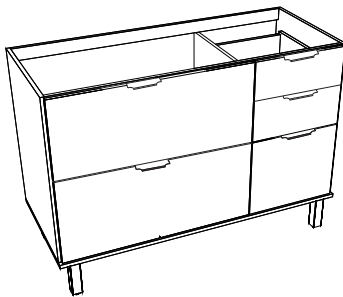

Rodovia SC-492 - Km 10 - B. Industrial
89905-000 - Bandeirante - SC
Fone: (49) 3622-4549
e-mail: mxmoveis@mxmoveis.com.br



Ref. BFL02

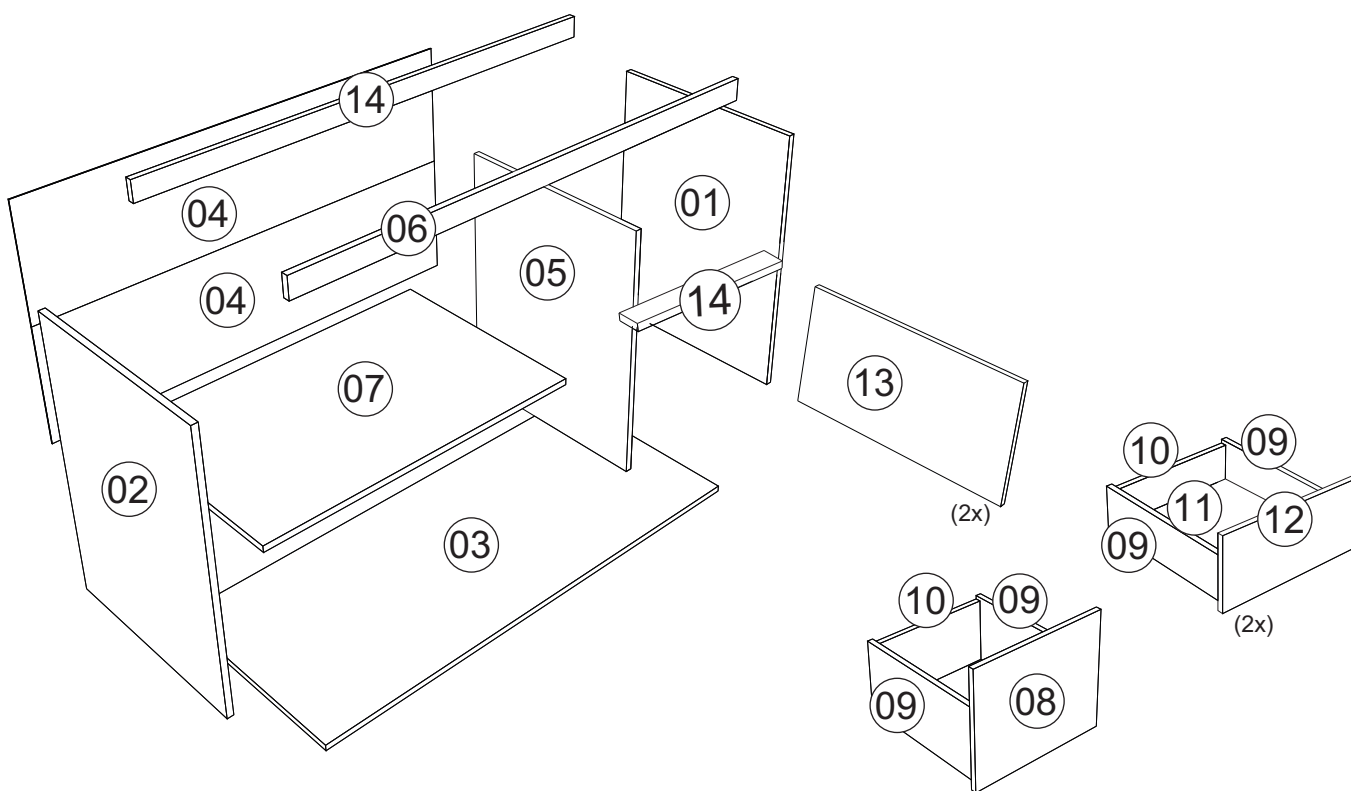

Balcão 1200 2P 3G
Balcón 1200
Counter 1200
Cozinha/Cocina
FLORENÇA



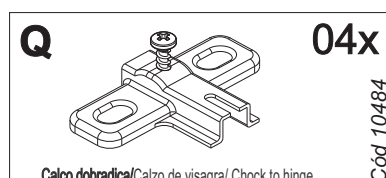
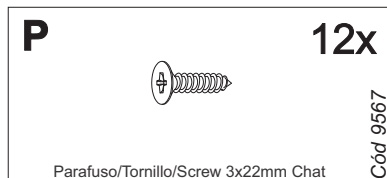
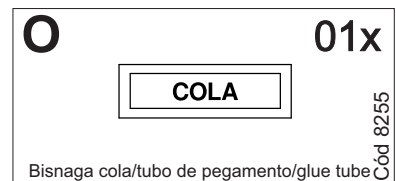
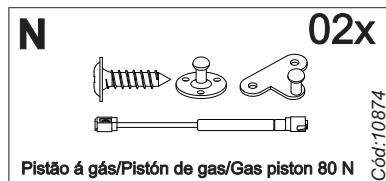
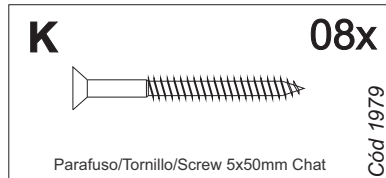
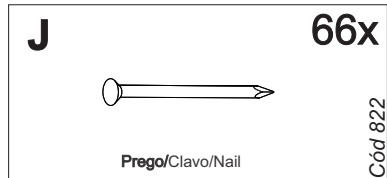
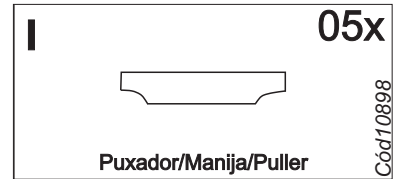
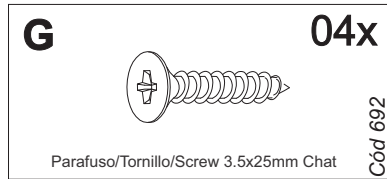
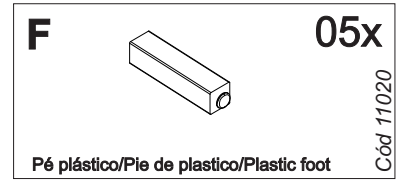
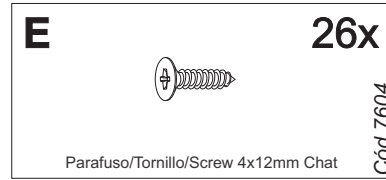
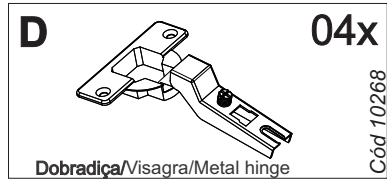
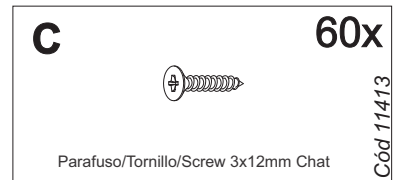
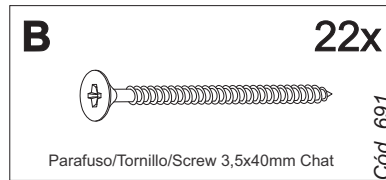
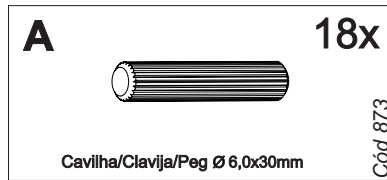

Nº	CÓDIGO CODE ASSISTÊNCIA ATTENDANCE	NOME DA PEÇA/DESCRIPCIÓN PIEZAS/DESCRIPTION PARTS	MEDIDAS (mm) MEASURES (mm)	QTD.	FENDI/CASTANHO
01	BFL02.17.00	Lateral externa direita/Lateral derecha/Right side	710x496x15	01	263488
02	BFL02.18.00	Lateral externa esquerda/Lateral izquierda/Left side	710x496x15	01	263489
03	BFL02.01.00	Base Inferior/Base/Shelf	1200x516x15	01	241666
04	BFL02.13.00	Forro/Revés/botton	1186X357x2.5	02	263491
05	BFL02.19.00	Lateral interna/Lateral interna/Inner side	660x496x15	01	263495
06	BFL02.28.00	Ripa sustentação frontal /Travesaño/front support slat	1170x50x15	01	241562
07	BFL02.02.00	Base interna/Base pequena/Shelf	795x496x15	01	263494
08	BFL02.14.00	Frente gaveta/Frente cajón/Drawer front	368x345x15	01	263477
09	BFL02.15.00	Lateral gaveta/Lateral cajón/ Drawer side	350x100x15	06	263492
10	BFL02.29.00	Ripa Traseira de gaveta/Trasero cajón/Drawer back	305x80x15	03	263493
11	BFL02.34.00	Forro gaveta/Revés cajón/Botton	355x335x15	03	263490
12	BFL02.14.01	Frente gaveta/Frente cajón/Drawer front	368x171x15	02	263478
13	BFL02.25.00	Porta/Puerta/Door	803x345x15	02	263476
14	BFL02.28.02	Ripa sustentação /Travesaño/front support slat	360x60x15	01	241786

Ferragens/Herrajes/Hardware



 *Usar os parafusos (G) para unir este módulo a outro. 
 Usar los tornillos (G) para unirse este módulo a otro.
 Use the screws (G) to join this module to another.

 *** Em caso de aquisição do tampo e roda tampo ***
 Este kit de ferragem possui 03 unidades a mais do parafuso (K), 8 (C) e 4 unidades do item (H). 



Medidas em mm
 Measures in mm
 Medidas en mm

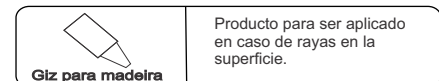
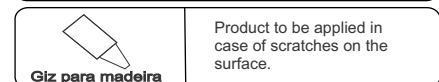
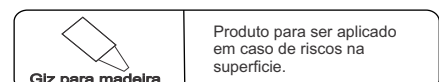
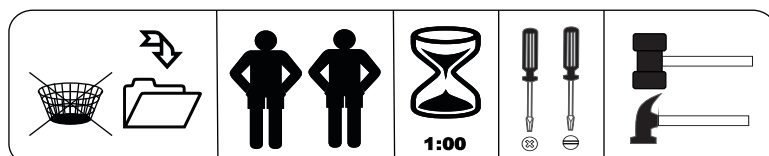

Pré-Montagem/Preparación Piezas/ Pre-assembly

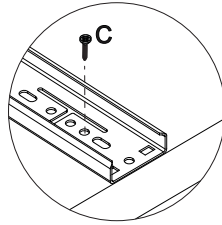
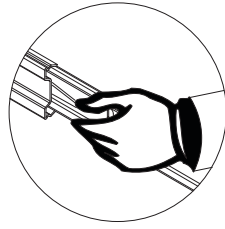

Soltar as partes da correção
 Afloje las piezas deslizantes
 Loosen the slide parts

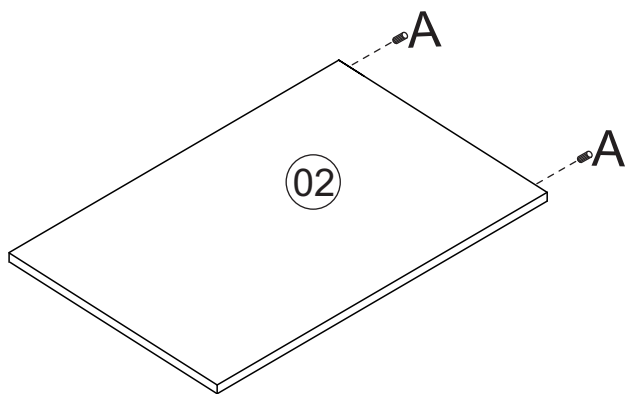
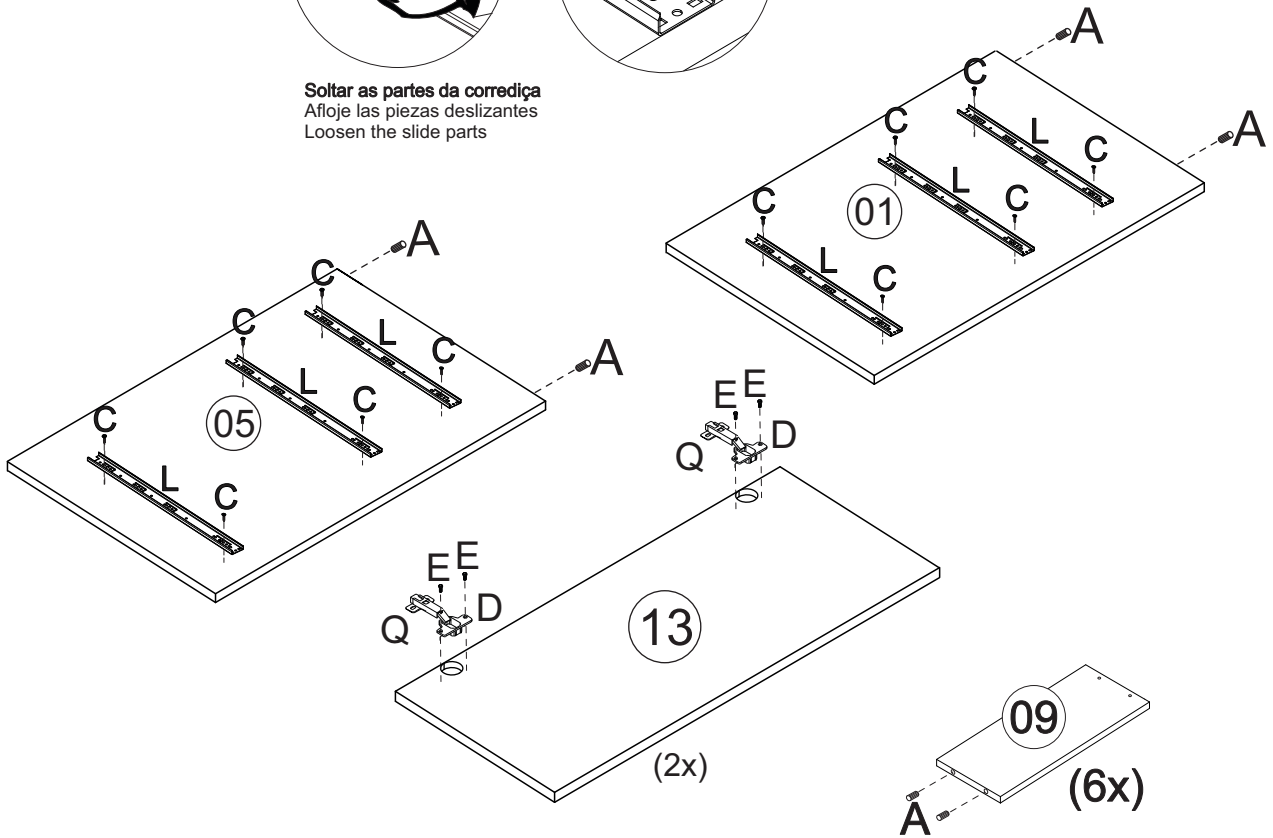

Utilizar cola nas cavilhas
 Usa pegamento en los tacos.
 Use glue on the dowels

01 → Montagem/Montaje/Assembly

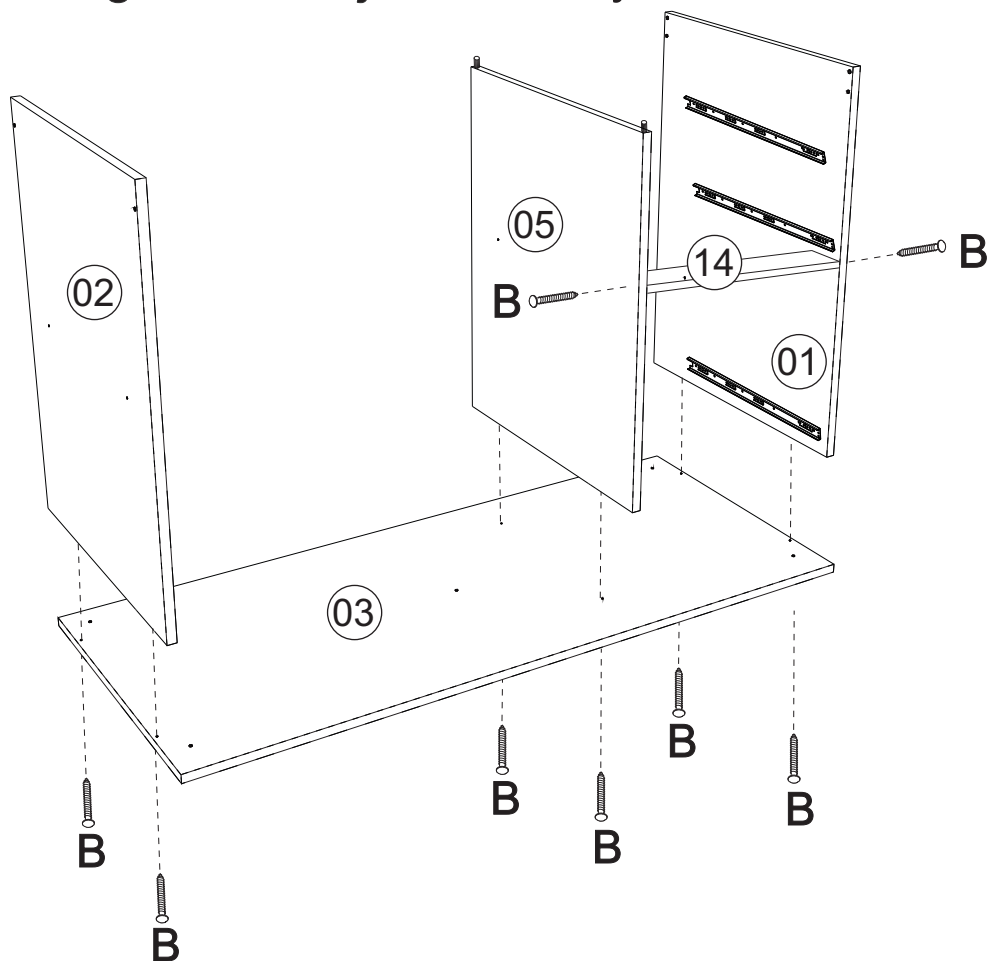

02 → Montagem/Montaje/Assembly

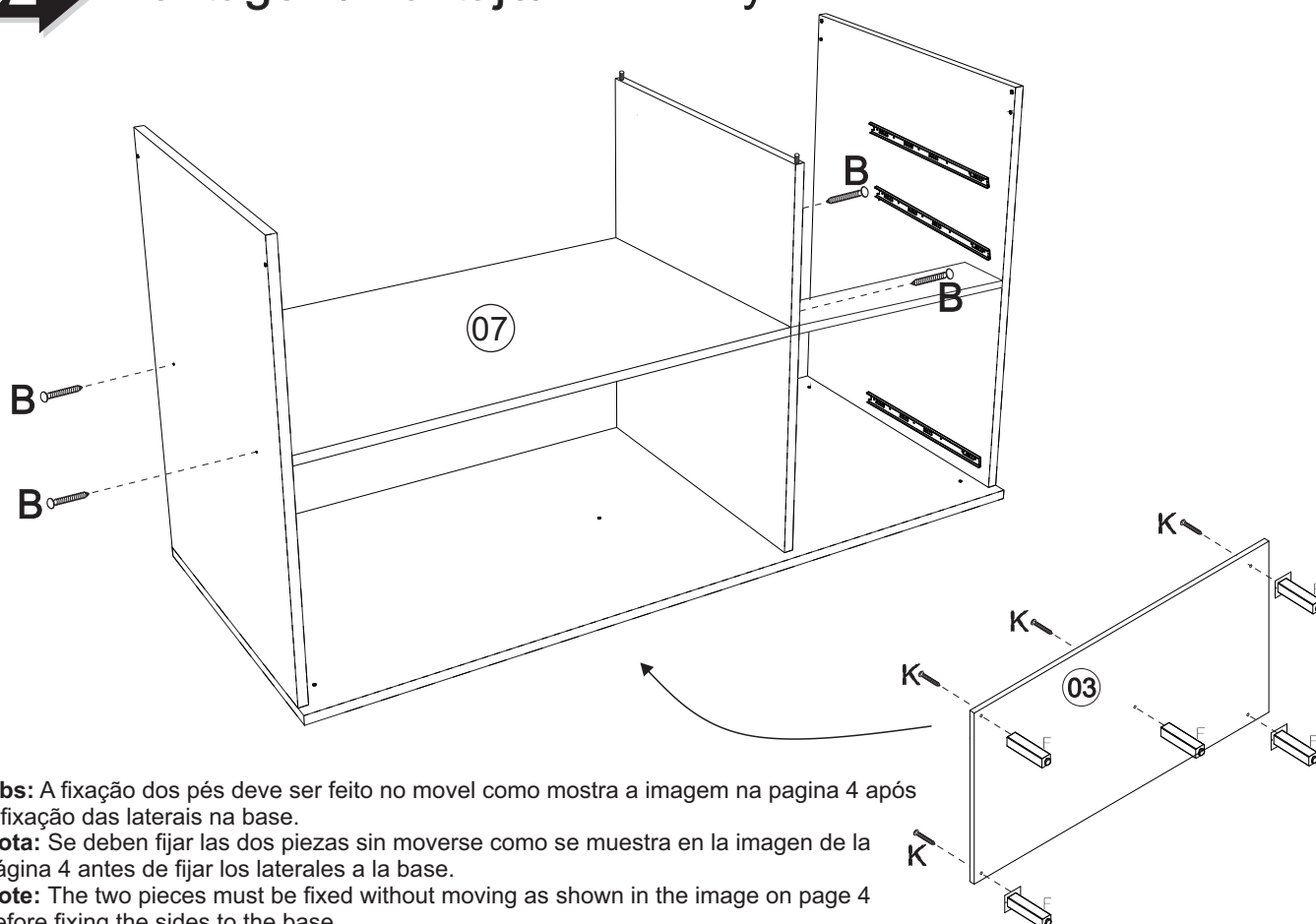

Obs: A fixação dos pés deve ser feito no movel como mostra a imagem na pagina 4 após a fixação das laterais na base.

Nota: Se deben fijar las dos piezas sin moverse como se muestra en la imagen de la página 4 antes de fijar los laterales a la base.

Note: The two pieces must be fixed without moving as shown in the image on page 4 before fixing the sides to the base.

03 Montagem/Montaje/Assembly

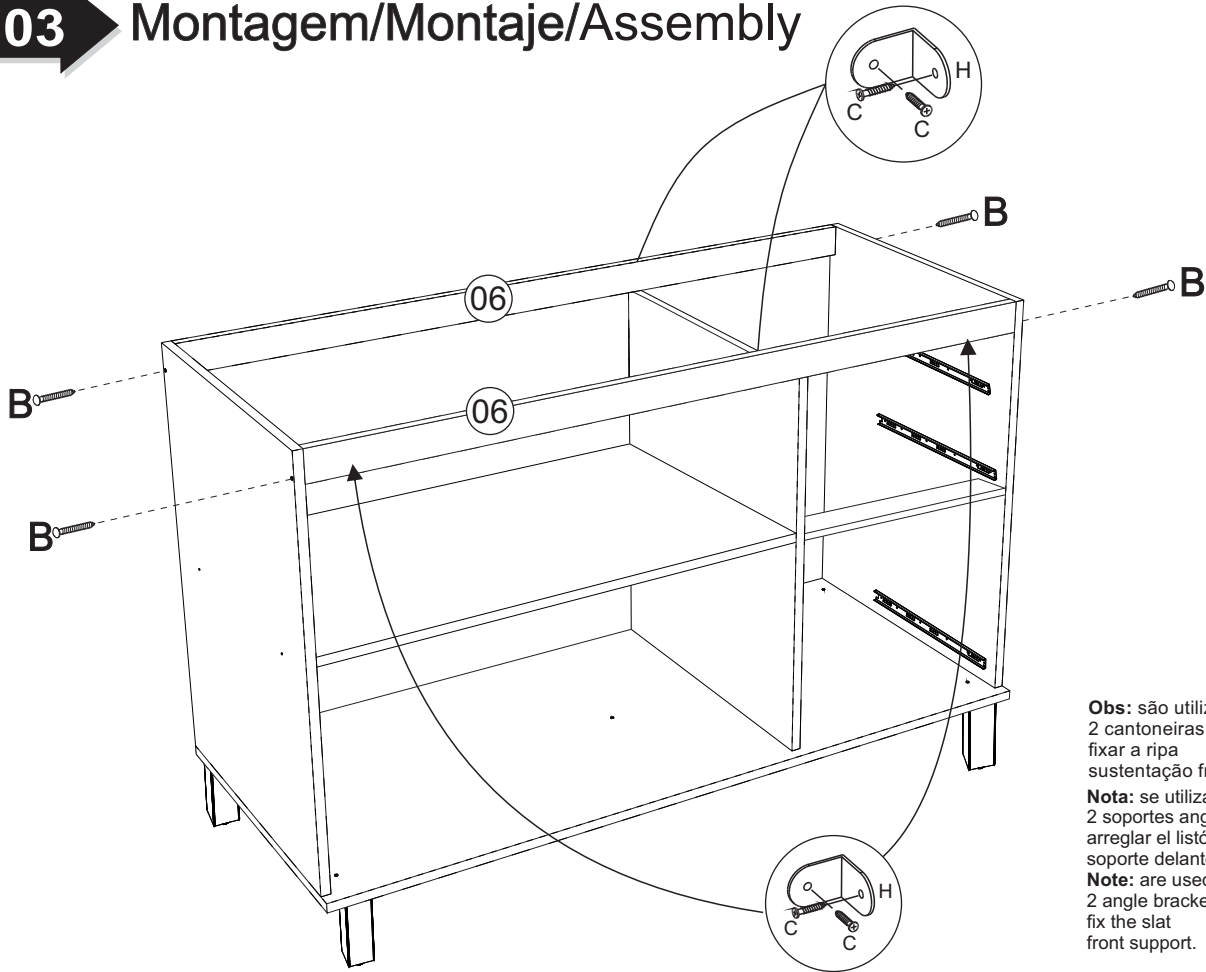

Obs: são utilizadas 2 cantoneiras para fixar a ripa sustentação frontal.

Nota: se utilizan 2 soportes angulares para arreglar el listón soporte delantero.

Note: are used 2 angle brackets for fix the slat front support.

04 Montagem/Montaje/Assembly

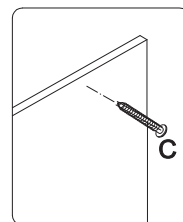
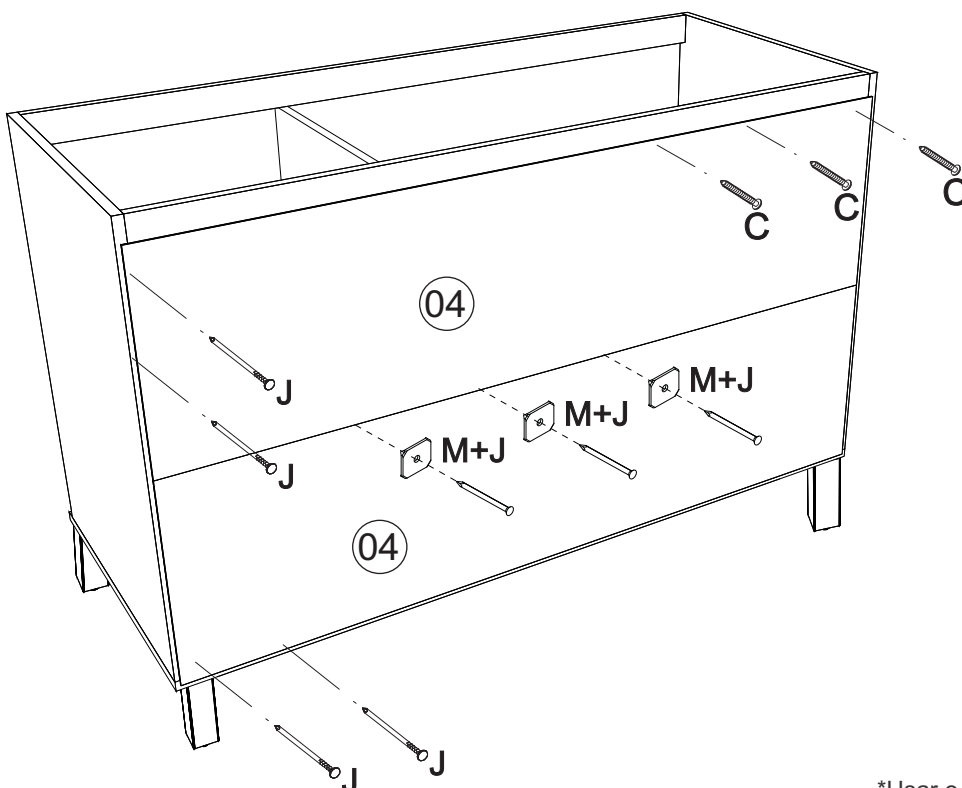

*Colocar um parafuso (C) a cada 100mm
*Colocar un tornillo (C) cada 100mm
*Place a screw (C) every 100mm

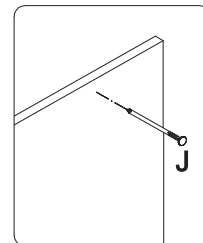

*Colocar um prego (E) a cada 100mm
*Colocar un clavo (E) cada 100mm
*Place a nail every (E) 100mm

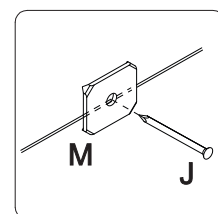

*Usar o prego (E) e a junção (I) a cada 100mm
*Usar el clavo (E) y la junta (I) cada 100mm
*Use the nail (E) and the joint (I) every 100mm

05 Montagem/Montaje/Assembly

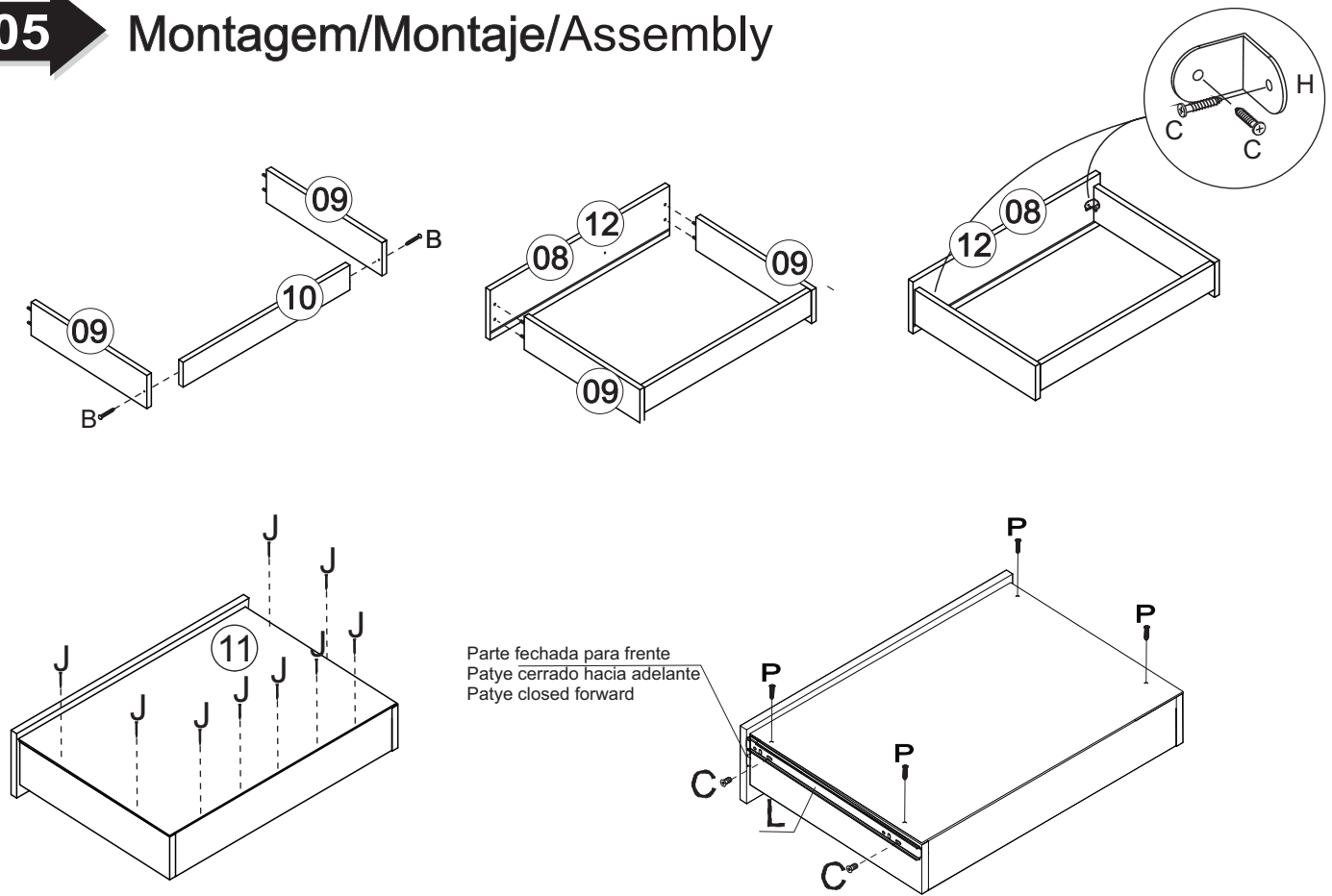

06 Montagem/Montaje/Assembly

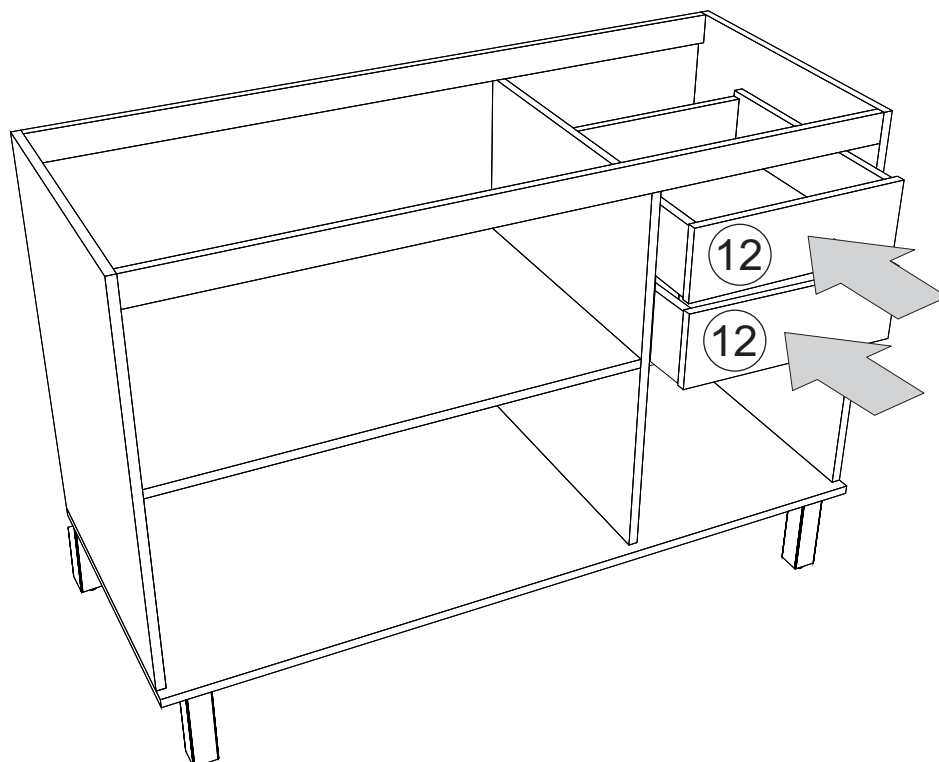

07 → Montagem/Montaje/Assembly

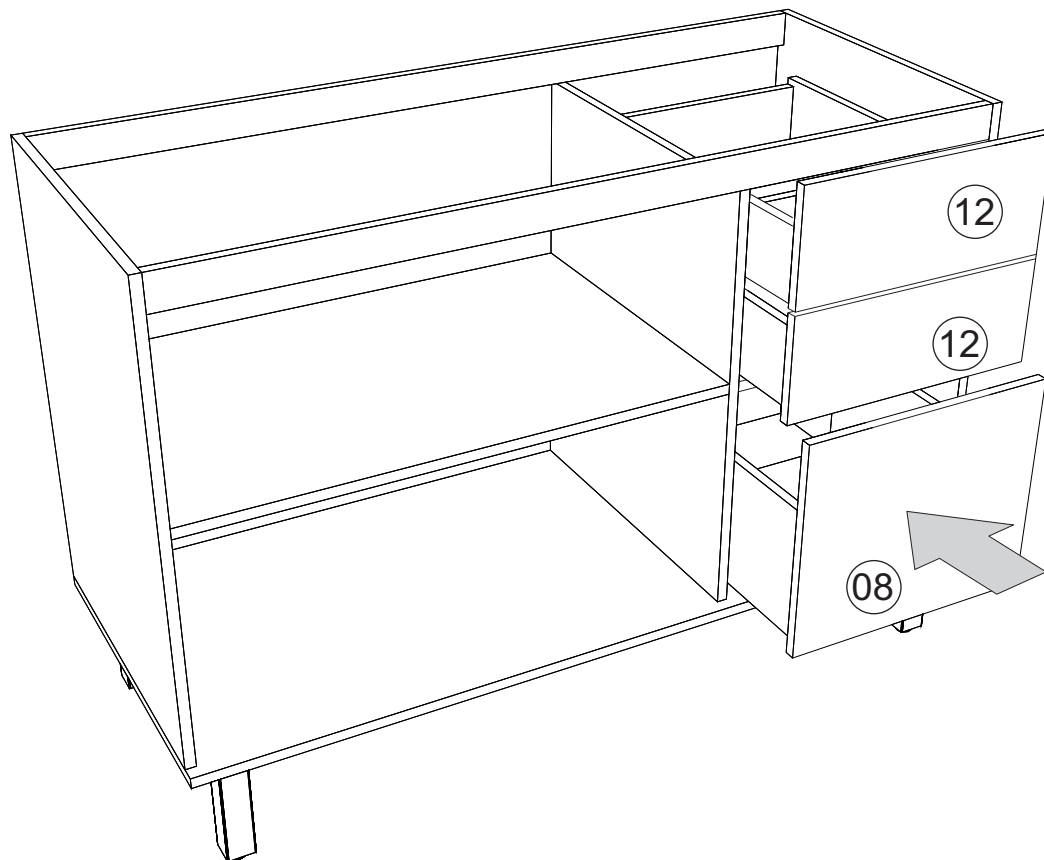

08 → Montagem/Montaje/Assembly

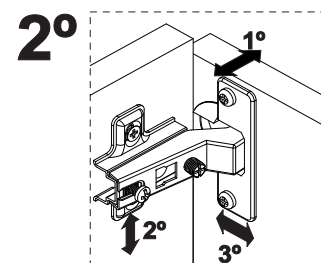
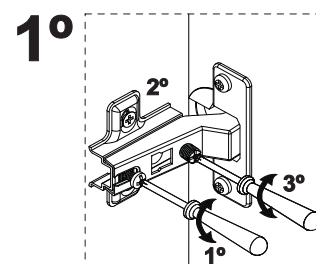
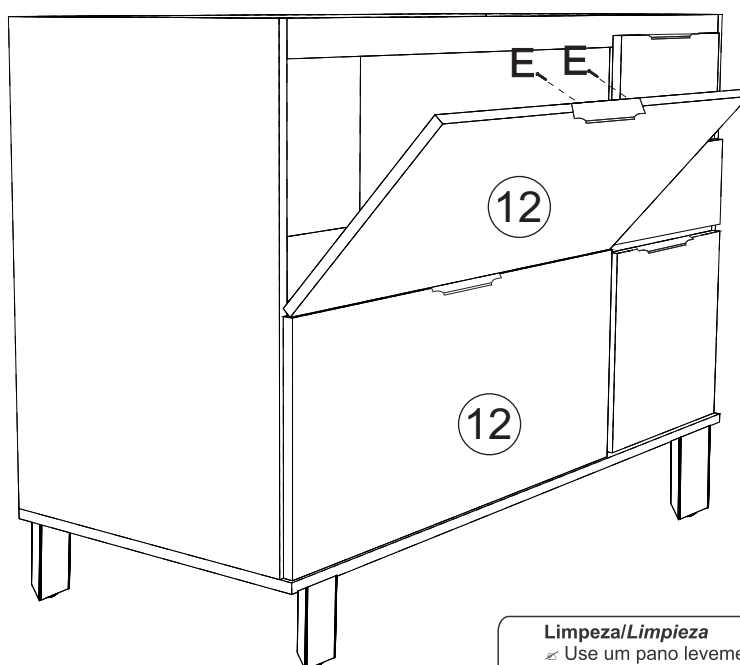

Limpeza/Limpieza

- ≠ Use um pano levemente umedecido com água, seguido de pano seco.
- ≠ Use solamente un paño húmedo con agua y después un paño seco.
- ≠ Use a cloth slightly dampened with water, followed by a dry cloth.
- ≠ Nunca utilize produtos químicos ou abrasivos.
- ≠ No utilice productos químicos o abrasivos.
- ≠ Never use chemical or abrasive products.