

## ASSEMBLY PROGRAM

### STEP 1

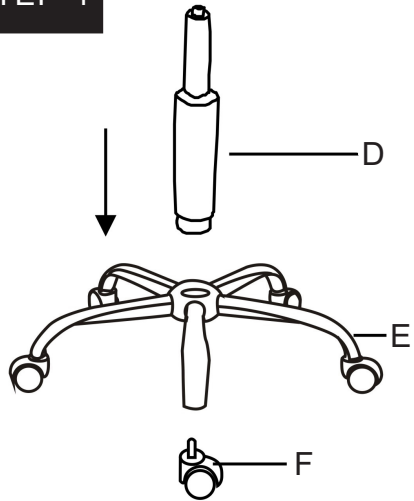

### STEP 2

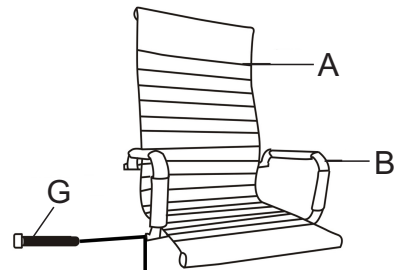

Be careful: Firstly fix this screw, do not lock tightly!

### STEP 3

Fix this screw.  
lock these two screws tightly together.  
the two armrests keep the same step.

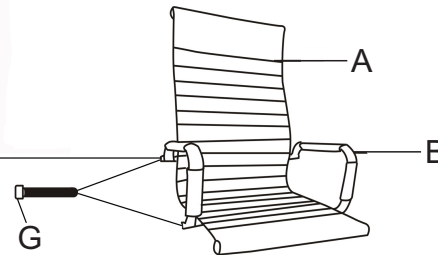

### STEP 4

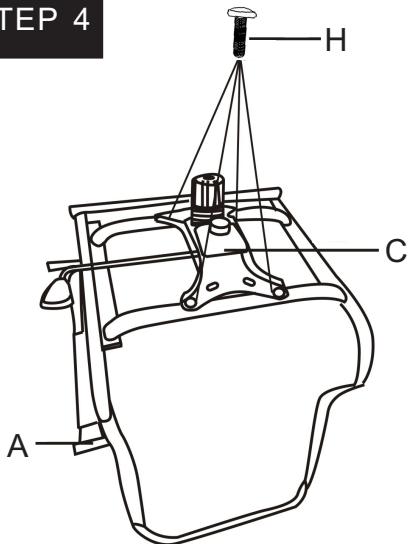



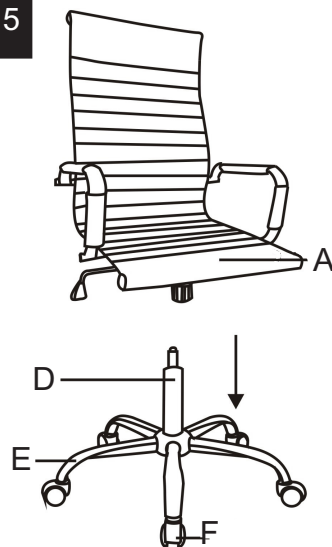





### STEP 5

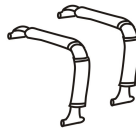

### FINISH

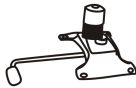

## PARTS x QTY

A=Seat Group x1	G=Screw(M8X50mm) x4
	
B=Armrest x2	H=Screw(M8X20mm) x4
	
C=Mechanism x1	I=Spanner x1
	
D=Gaslift x1	
	
E=Base x1	
	
F=Castor x5	
