

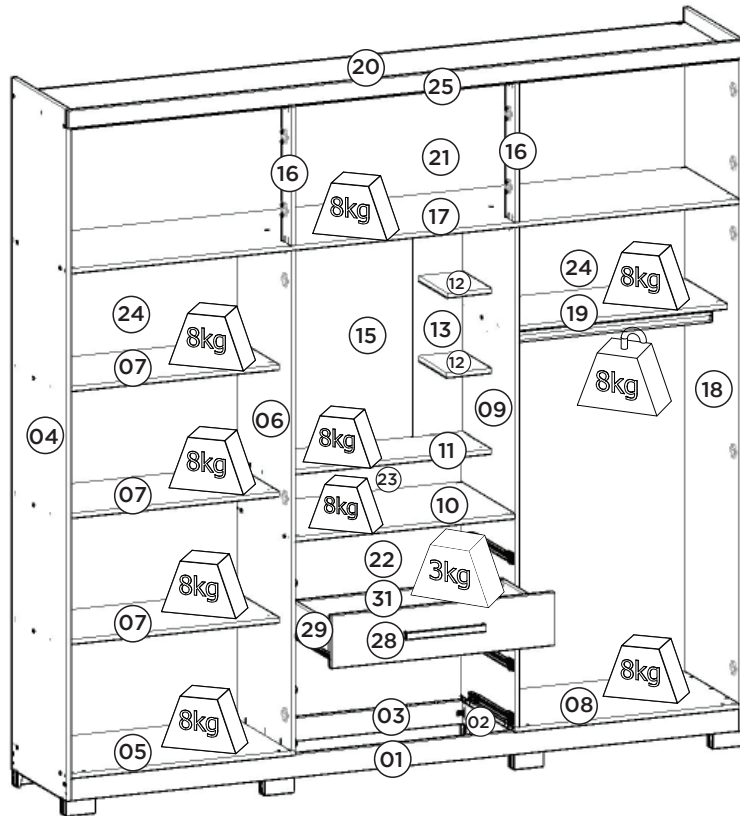

ROUPEIRO VIENA 10 PORTAS
ARMARIO VIENA 10 PUERTAS | VIENA 10 WARDROBE DOORS
D203-106 RÚSTICO/OFF WHITE | D203-127 NATURE/OFF WHITE
| D203-130 CASTANHO HP | D203-198 JEQUITIBÁ BRILHO

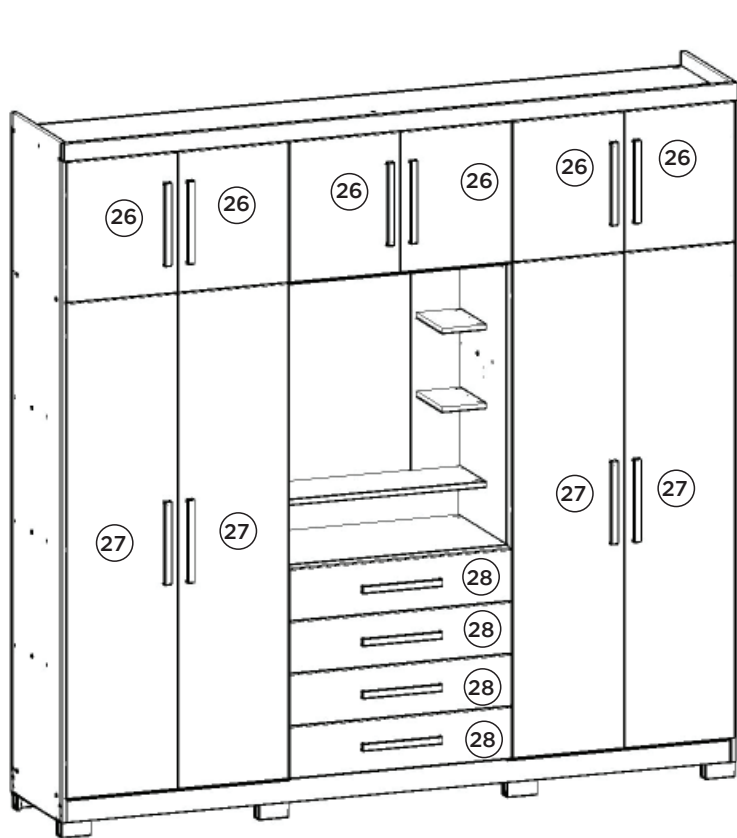

Pesos máximos recomendados com carga distribuída
Peso máximo recomendado con la carga distribuida
Recommended maximum weights with evenly distributed.

Requisitos para montagem
Requisitor para la montaje
Assembly Requirements

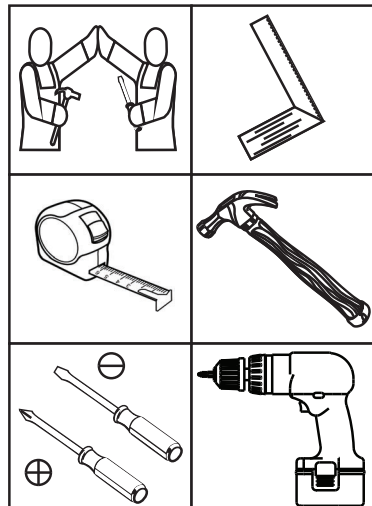

Imagens meramente ilustrativas
Imágenes meramente ilustrativas
Images for illustration only

AVISO

Para limpeza de seu móvel, use uma franela seca ou umedecida, e não utilize produtos químicos que possam danificar seu produto.

SISTEMA DE MONTAGEM

O sistema de montagem dos produtos, funciona de acordo com a ordem crescente dos números indicados no desenho. Ex: 01, 02, 03, 04... até a conclusão da montagem.

ASSISTÊNCIA TÉCNICA

Para solicitação de Assistência Técnica você consumidor deverá entrar em contato com o Lojista o qual você realizou a compra deste produto e solicitar a assistência técnica das peças avariadas. A garantia abrange todas as peças, partes e componentes que eventualmente venham apresentar defeito de fabricação no prazo de 03 (três) meses, contando a partir da entrega do produto ao consumidor, mediante nota fiscal de compra. Se houver qualquer alteração na estrutura do produto ou ocorrer defeito por negligência do montador/consumidor em relação a instrução de montagem e manuseio, não será fornecido assistência técnica gratuita.

ADVERTENCIA

Para limpieza de su móvil, use una franela seca o húmeda, y no utilice productos químicos que puedan dañar su producto.

SISTEMA DE MONTAJE

El sistema de montaje de los productos funciona de acuerdo con el orden creciente de los números indicados en el dibujo. Ej.: 01, 02, 03, 04... hasta la conclusión del montaje.

ASISTENCIA TÉCNICA

Para solicitar Asistencia Técnica, el consumidor debe comunicarse con el Comercio que usted realizó la compra de este producto y solicita asistencia técnica para las partes dañadas. La garantía cubre todas las partes, piezas y componentes que eventualmente puedan presentar defecto de fabricación en el plazo de 03 (tres) meses, contados a partir de la entrega del producto al consumidor, mediante factura de compra. Si se produce algún cambio en la estructura del producto o se produce un defecto por negligencia del montador/consumidor en relación con las instrucciones de montaje y manipulación, no se prestará asistencia técnica gratuita.

NOTICE

To clean your furniture, use a dry or wet cloth, and do not use chemicals that may damage your product.

ASSEMBLY SYSTEM

The products' assembly system works according to the increasing order of the indicated numbers. For example: 01, 02, 03, 04 ... to the end of the assembly.

TECHNICAL ASSISTANCE

To request Technical Assistance, the consumer must contact the retailer from whom you purchased this product and request technical assistance for the damaged parts. The warranty covers all parts, parts and components that may eventually present a manufacturing defect within a period of 03 (three) months, counting from the delivery of the product to the consumer, by means of a purchase invoice. If there is any change in the structure of the product or defect occurs due to negligence of the assembler/consumer in relation to the assembly and handling instruction, free technical assistance will not be provided.

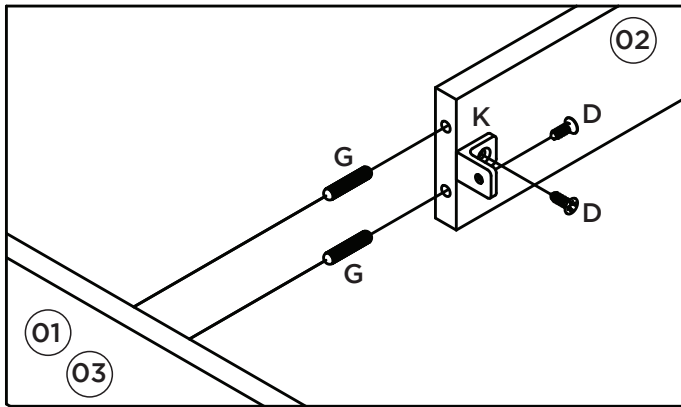
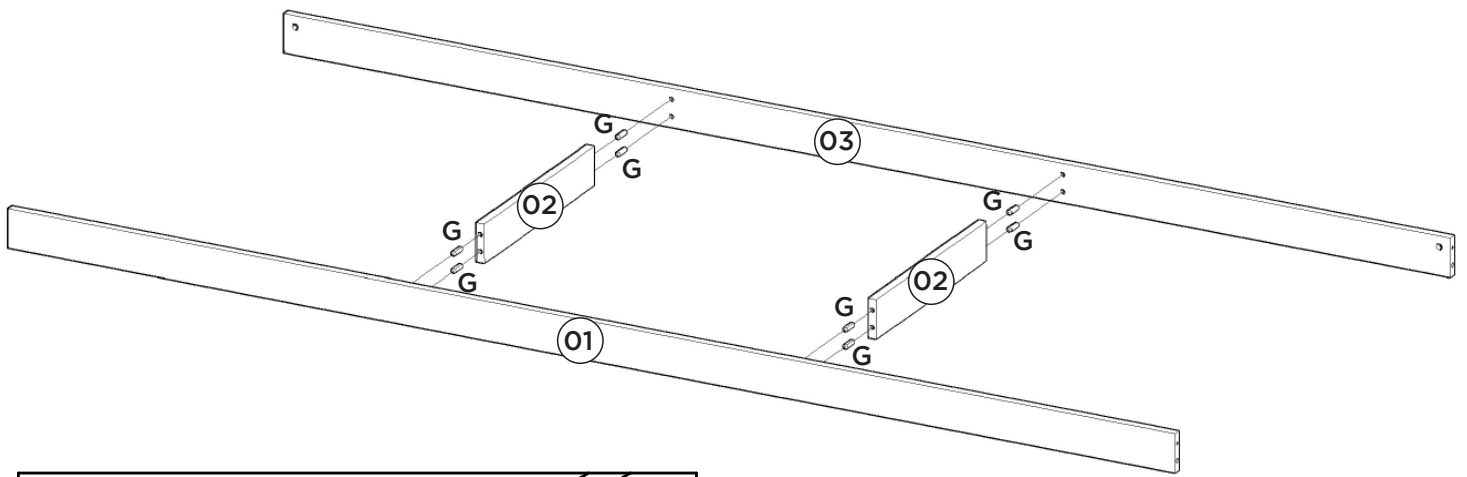

As peças 05 e 06 devem ser montadas separadamente, antes de fixar no produto.

Las piezas 05 y 06 se montará por separado antes de fijarse en el producto.

Parts 05 and 06 must be assembled separately before attaching to the product.

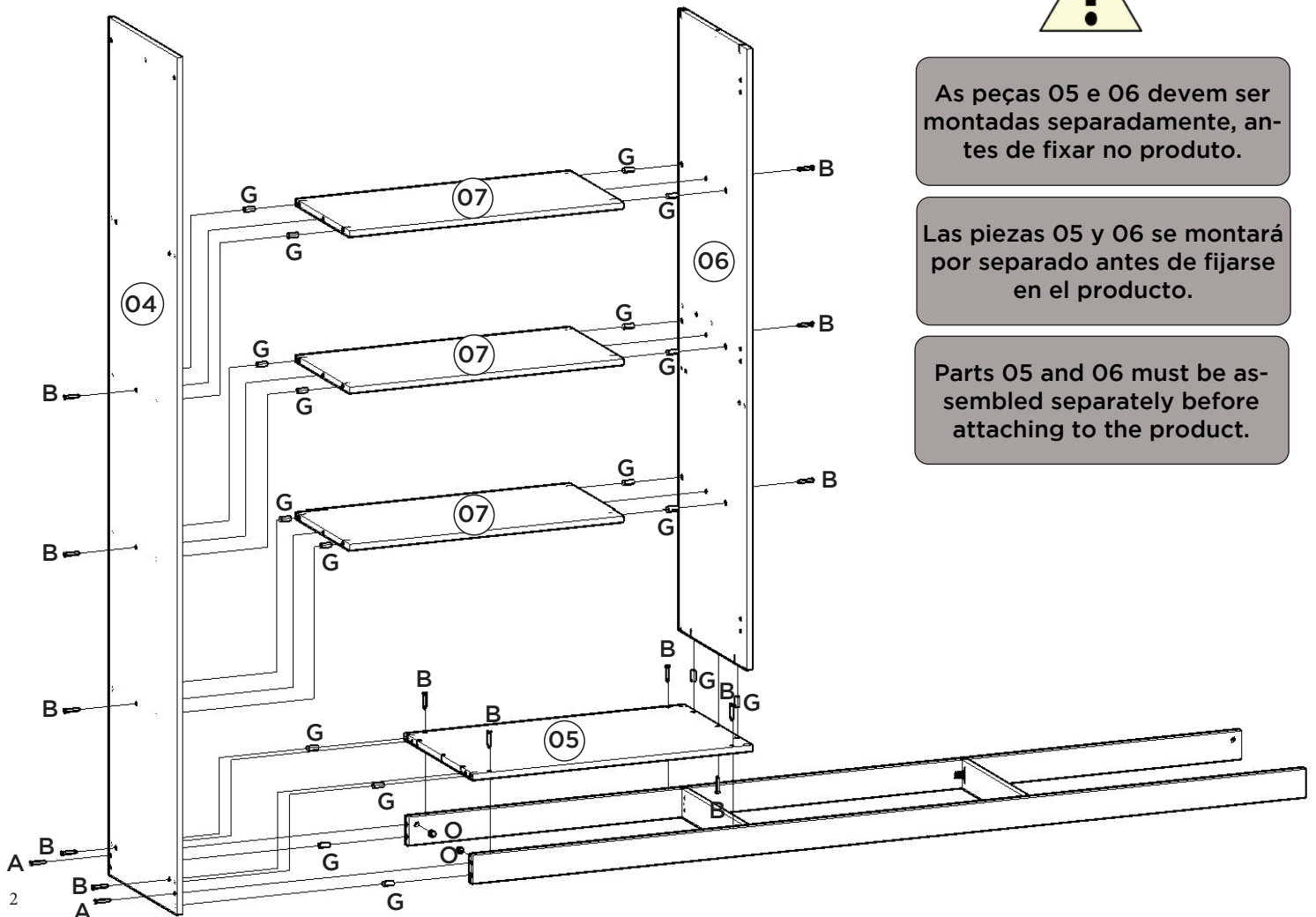

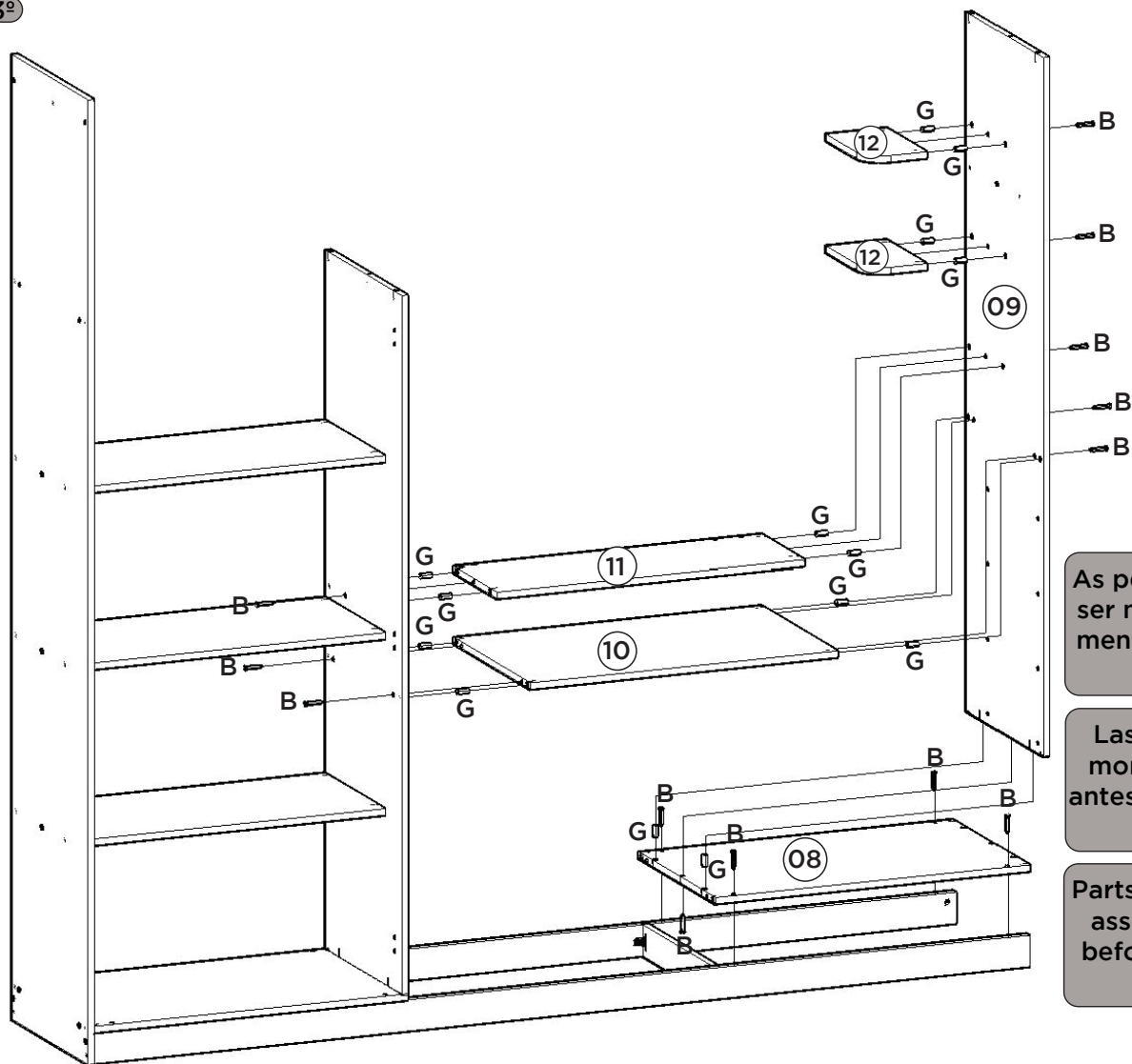

As peças 08 e 09 devem ser montadas separadamente, antes de fixar no produto.

Las piezas 08 y 09 se montará por separado antes de fijarse en el producto.

Parts 08 and 09 must be assembled separately before attaching to the product.

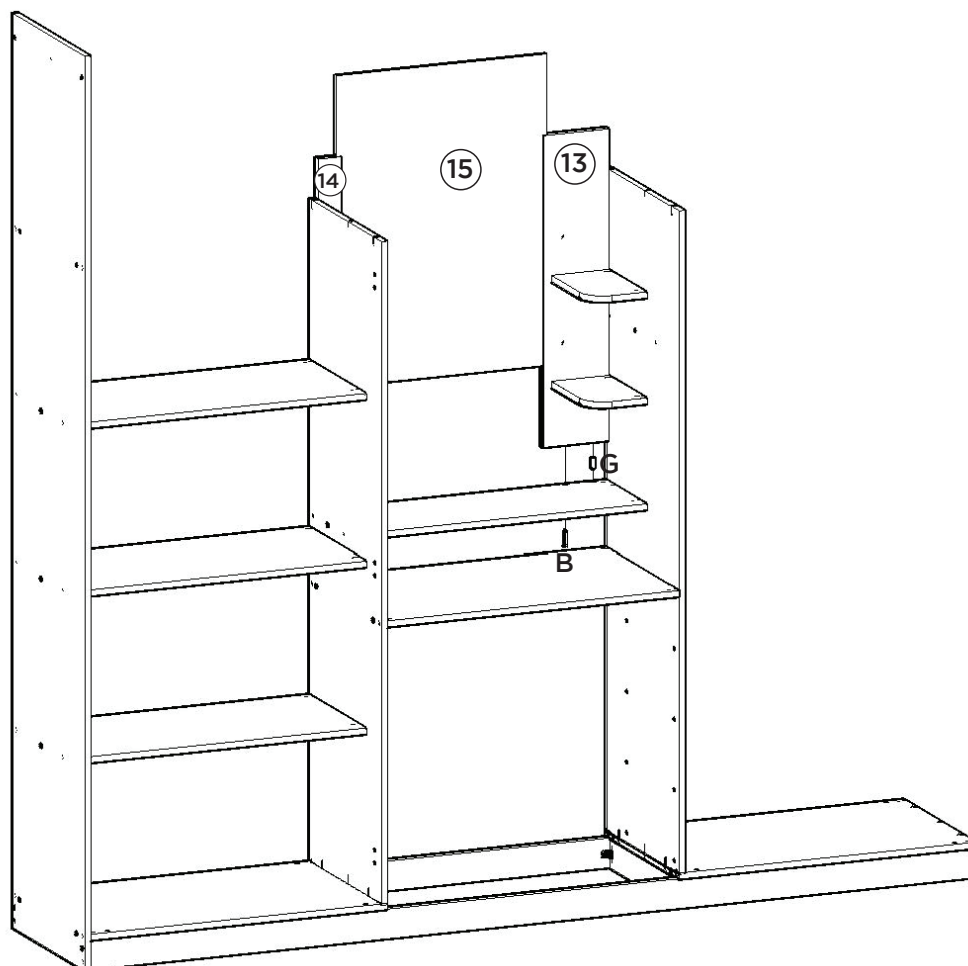

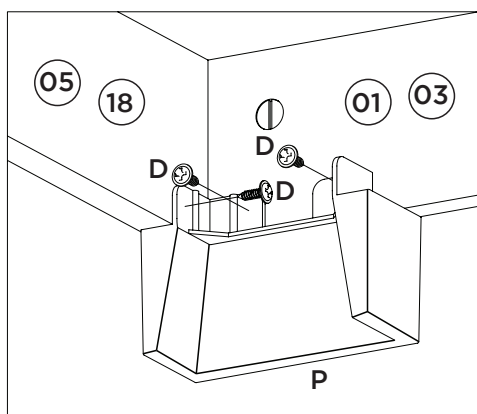
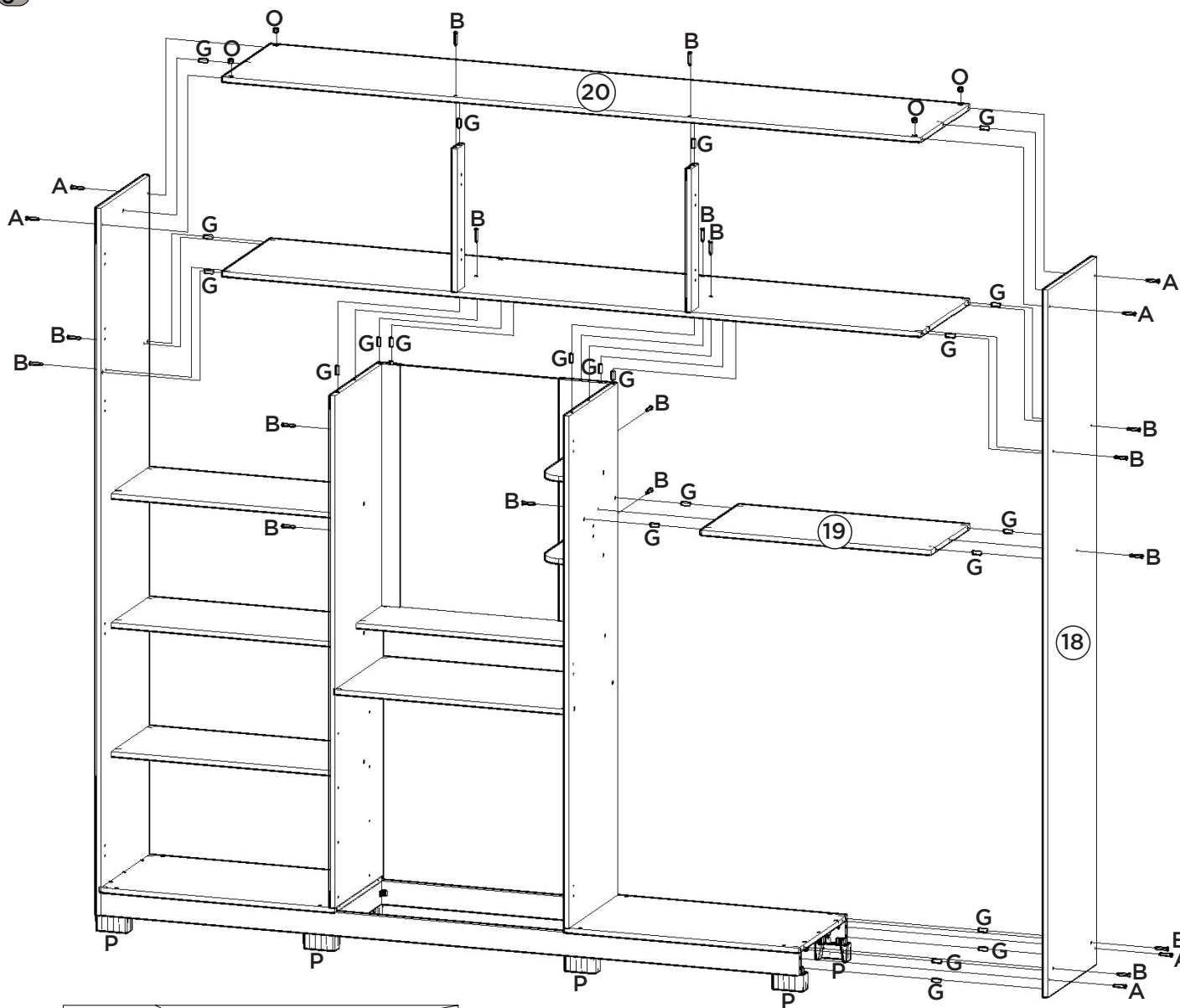
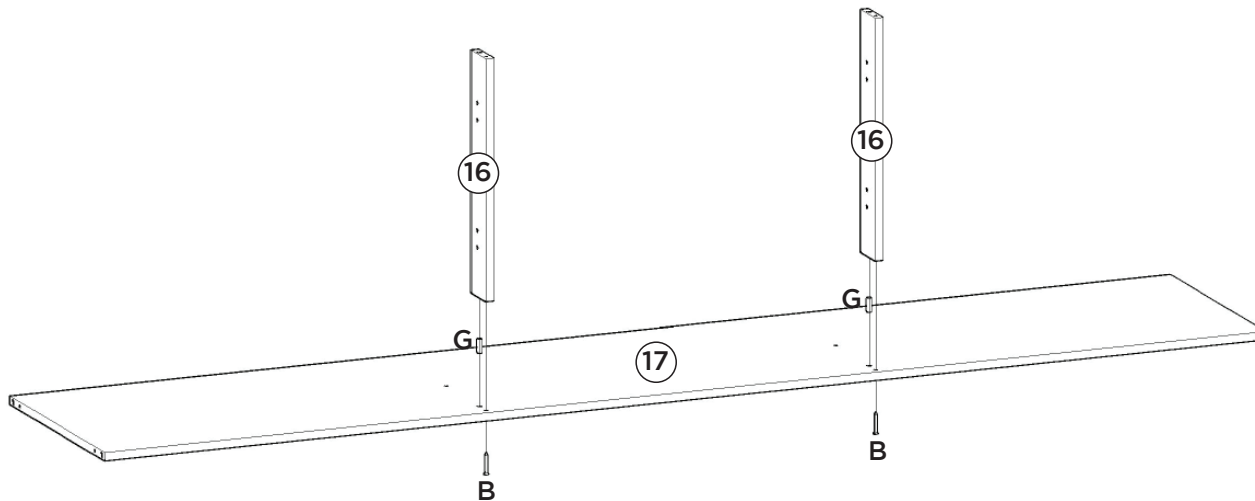

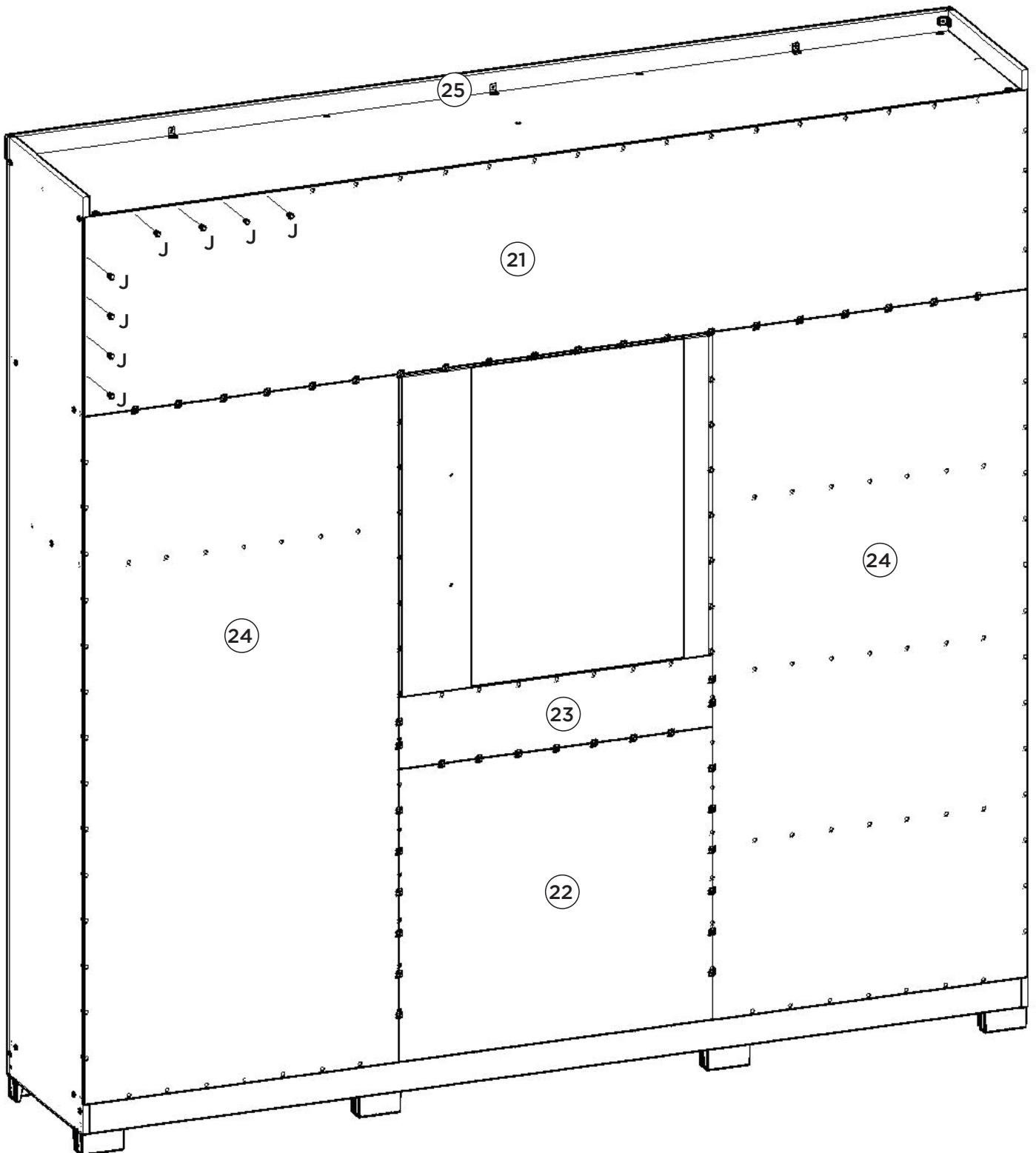
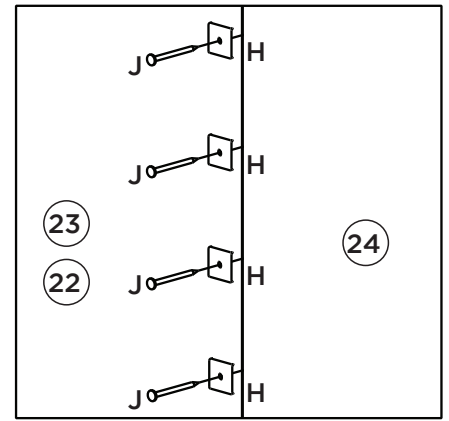
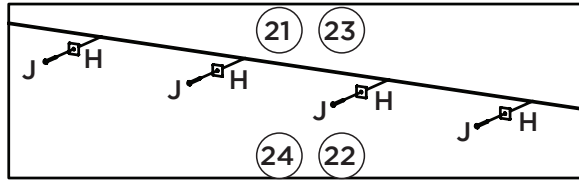
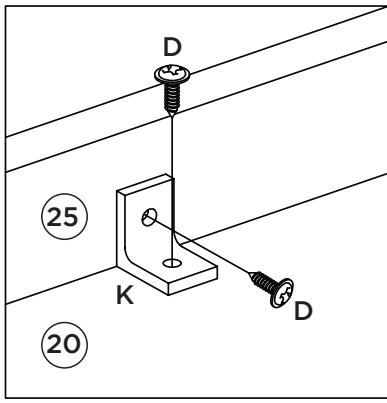

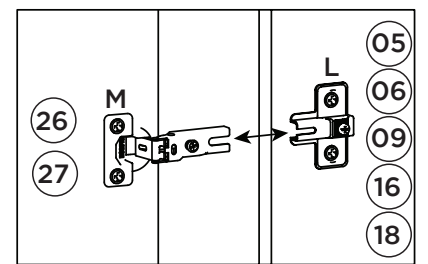
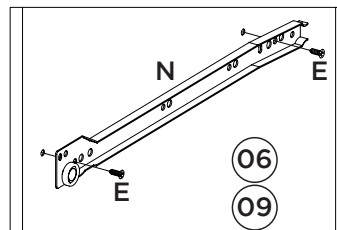
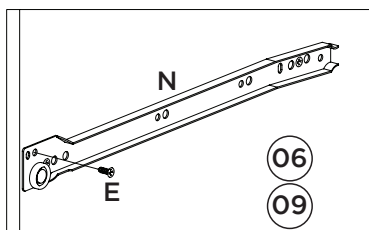
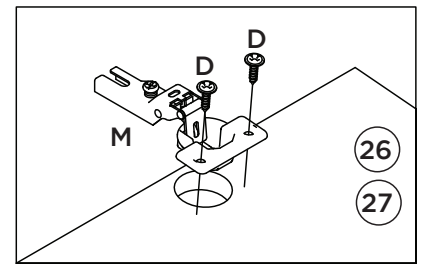
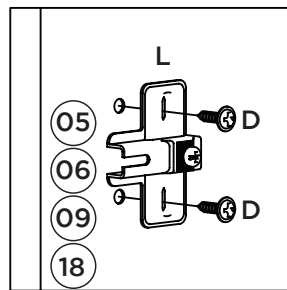
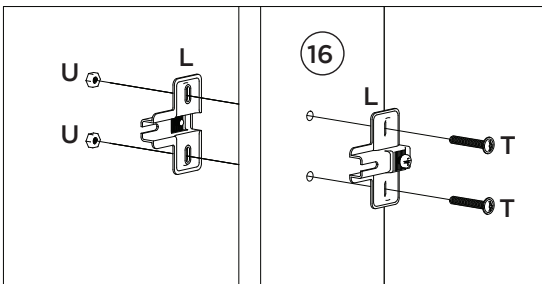
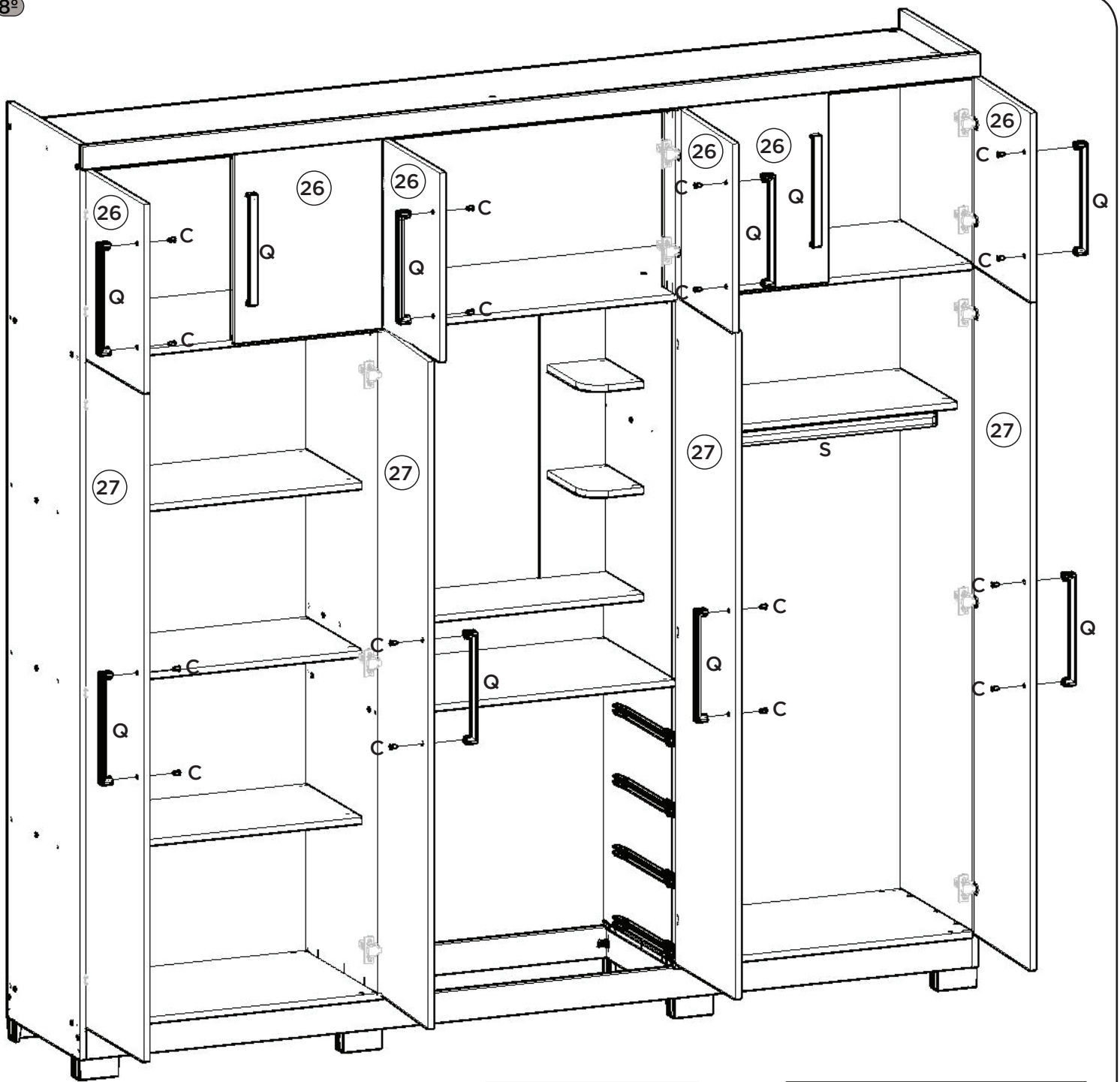

Video: Dicas para instalar corrediça

Video: consejos para instalar la diapositiva

Video: Tips for installing slide

Video: Instalar e regular Dobradiças

Video: Instale y ajuste las bisagras

Video: Install and adjust hinges



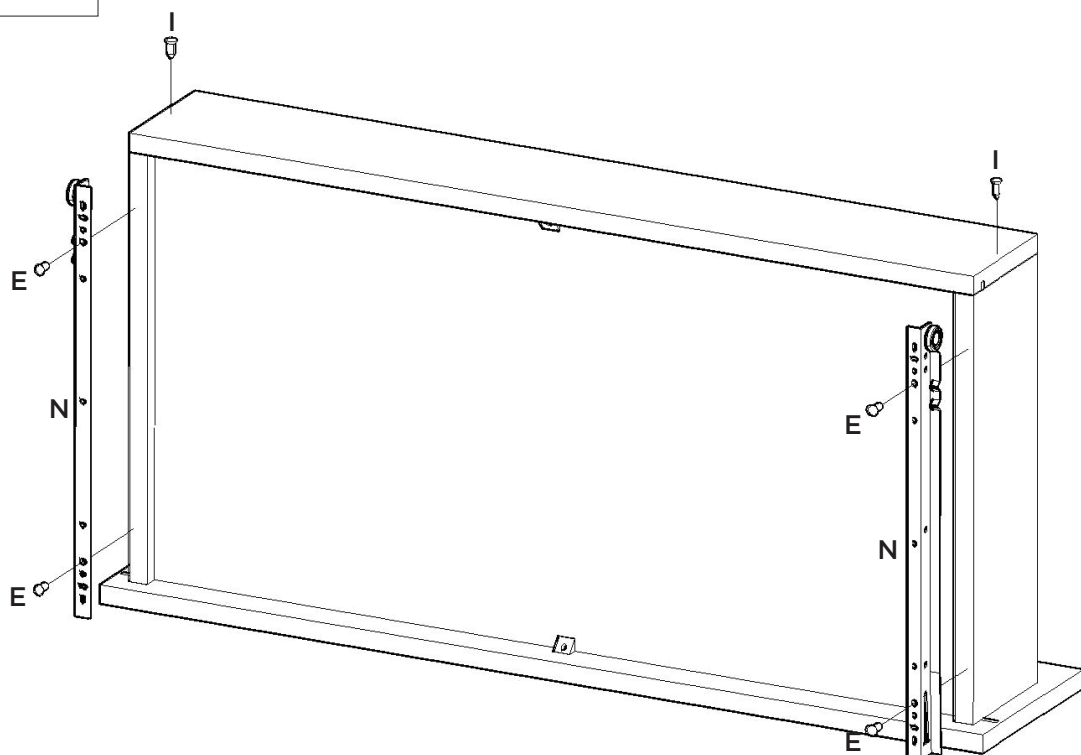
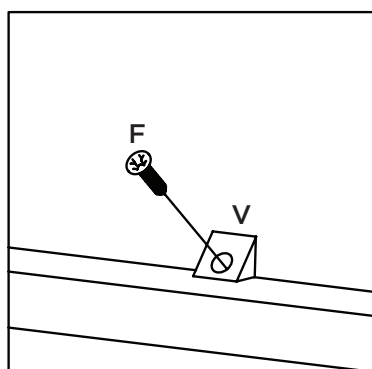
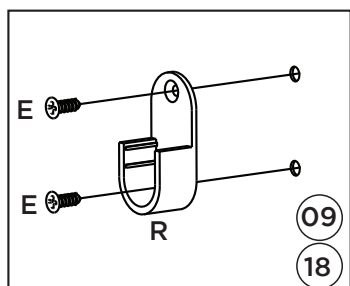
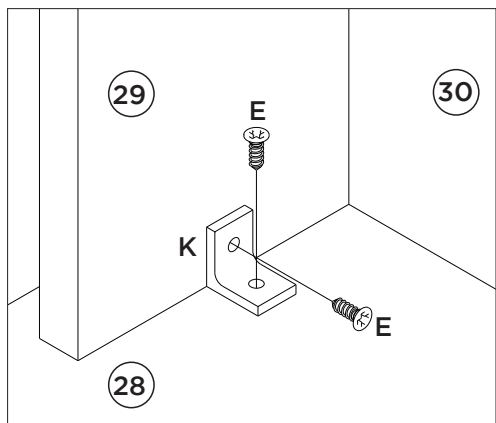
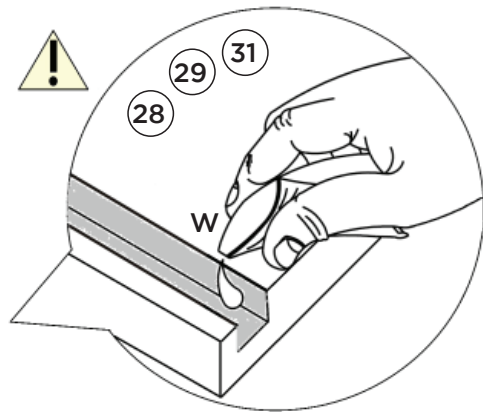
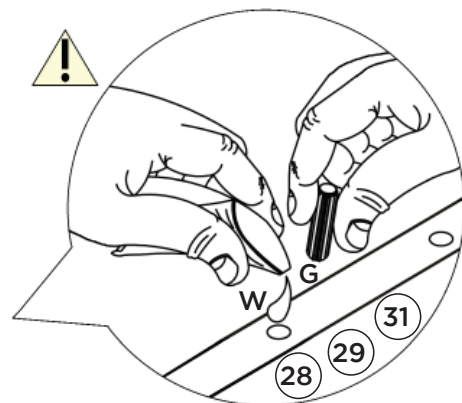
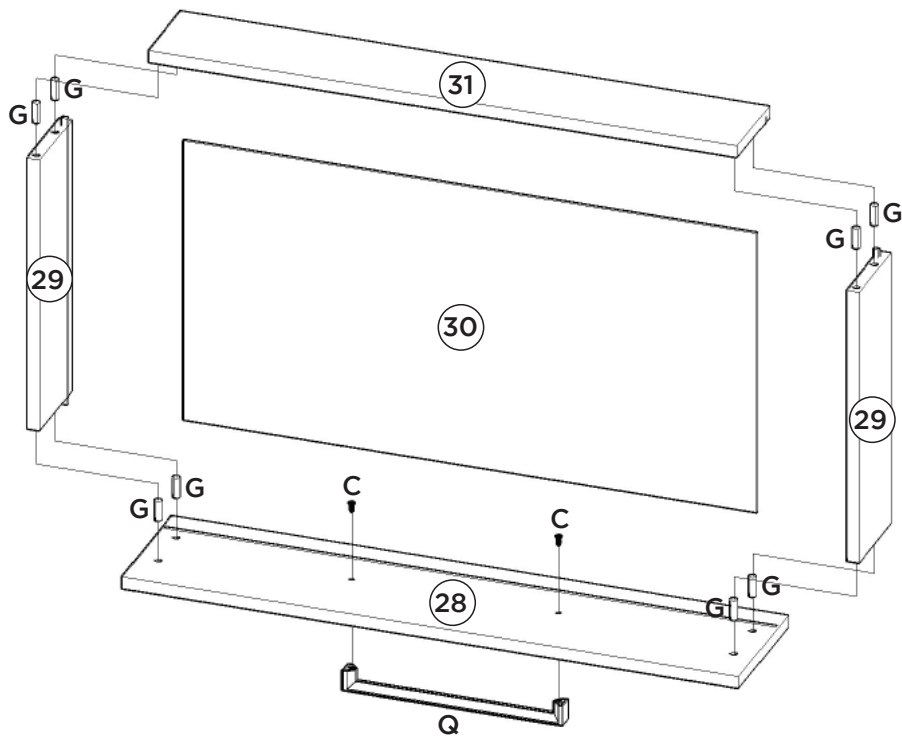







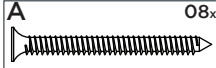





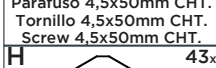
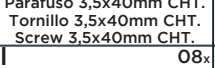
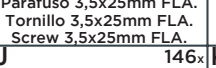



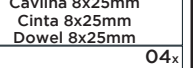
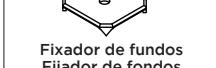

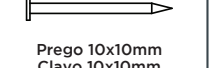

LISTA DE PEÇAS | LISTA DE PIEZAS | PARTS LIST

Item	Caixa Caja Box	Qtd Ctd Qty	Descrição Descripción Description	Medidas (mm) Dimensions (mm) Size (measurements) (mm)
01	2/4	01	Rodapé frontal Rodapié frontal Front footboards	2289x73x15
02	2/4	02	Travessa do rodapé Carril pie Footboard tray	409x73x15
03	2/4	01	Rodapé traseiro Rodapié trasero Rear footboard	2289x73x15
04	1/4	01	Lateral esquerda Lateral izquierda Left side	2250x445x15
05=08	3/4	01	Base Base Base	768x445x15
06	1/4	01	Divisão esquerda División izquierda Left division	1629x445x15
07=19	2/4	03	Prateleira Estante Shelf	753x350x15
08=04	3/4	01	Base Base Base	768x445x15
09	1/4	01	Divisão direita División derecha Right division	1629x445x15
10	2/4	01	Tampa da cômoda Cubierta de la cómoda Dresser cover	753x445x15
11	2/4	01	Prateleira Central Estantería central Central Shelf	753x250x15
12	1/4	02	Prateleira Menor Estantería Menor Smaller Shelf	235x150x15
13	2/4	01	Moldura Lateral Maior Marco Lateral Mayor Larger Side Frame	768x170x15
14	2/4	01	Moldura lateral Cornija lateral Side frame	768x60x15
15	4/4	01	Espelho Espejo Mirror	767x544x3
16	2/4	02	Ripa do maleiro Portaequipajes de ripa Lath of the closet top shelf	455x68x15
17	2/4	01	Chão do maleiro Piso del portaequipajes Floor of the closet top shelf	2289x445x15
18	1/4	01	Lateral direita Lateral derecha Right side	2250x445x15
19=07	2/4	01	Prateleira Estante Shelf	753x350x15
20	2/4	01	Tampo Tapa Top	2289x445x15
21	2/4	01	Fundo Superior Fondo Superior Top Bottom	2311x477x3
22	4/4	01	Fundo cru Fondo sin procesar Raw bottom	770x699x3
23	4/4	01	Fundo menor Fondo menos Smaller bottom	770x170x3
24	4/4	02	Fundo Fondo Bottom	1646x770x3
25	2/4	01	Chapéu Sombrero Hat	2317x55x15
26	1/4 e 4/4	06	Porta Menor Puerto Menor Door Minor	465x380x15
27	4/4	04	Porta Puerta Door	1641x380x15
28	4/4	04	Frente de gaveta Frente del cajón Drawer front	763x170x15
29	3/4	08	Lado de gaveta Lado del cajón Drawer side	350x110x15
30	3/4	04	Fundo de gaveta Fondo del cajón Drawer bottom	709x361x3
31	3/4	04	Ripa de trás Listón trasero Rear batten	728x110x15

FERRAGENS / HERRAJES / HARDWARE

A  Parafuso 4,5x50mm CHT. Tornillo 4,5x50mm CHT. Screw 4,5x50mm CHT.	B  Parafuso 3,5x40mm CHT. Tornillo 3,5x40mm CHT. Screw 3,5x40mm CHT.	C  Parafuso 3,5x25mm FLA. Tornillo 3,5x25mm FLA. Screw 3,5x25mm FLA.	D  Parafuso 3,5x14mm FLA. Tornillo 3,5x14mm FLA. Screw 3,5x14mm FLA.	E  Parafuso 3,5x12mm CHT. Tornillo 3,5x12mm CHT. Screw 3,5x12mm CHT.	F  Parafuso 3,0x16mm CHT. Tornillo 3,0x16mm CHT. Screw 3,0x16mm CHT.	G  Cavilha 8x25mm Cinta 8x25mm Dowel 8x25mm
H  Fixador de fundos Fijador de fondos Bottom fixer	I  Parafuso 3,0x30mm CHT. Tornillo 3,0x30mm CHT. Screw 3,0x30mm CHT.	J  Prego 10x10mm Clavo 10x10mm Nail 10x10mm	K  Cantoneira plástica Cantонера plástica Plastic angle brackets	L  Calço metal 5mm Calzado metálico 5mm 5 mm metal shim	M  Dobradiça metal 26mm Bisagra de metal 26mm 26 mm metal hinge	N  Corrediza metal 350mm Corredera de metal 350mm Sliding metal 350mm
O  Porca cilíndrica Tuerca cilíndrica Cylindrical nut	P  Pé "U" 50x40x100mm Pie "U" 50x40x100mm 50x40x100mm "U" feet	Q  Puxador Luxor 256mm Tirador Luxor 256mm 256mm Luxor Handle	R  Suporte cabideiro Soporte de percha Coat hanger support	S  Cabideiro Alum. 745mm Alum. 745mm percha Alum. coat hanger 745mm	T  Parafuso 4,0x25mm FLA MET. Tornillo 4,0x25mm FLA MET. Screw 4,0x25mm FLA MET.	U  Porca sextavada Tuerca hexagonal Hex Nut
V  Cantoneira suporte triangular Cantонера soporte triangular Triangle support angle	W  Sachê de cola Bolsa de pegamento Glue bag	X  Adesivo tapa parafuso 10mm Adhesivo tapón de tornillo 10mm Bolt cover adhesive 10mm	Y  Etiqueta resinada Henn Etiqueta resinada Henn Henn resin label			