

2303 x 2301 x 463 mm

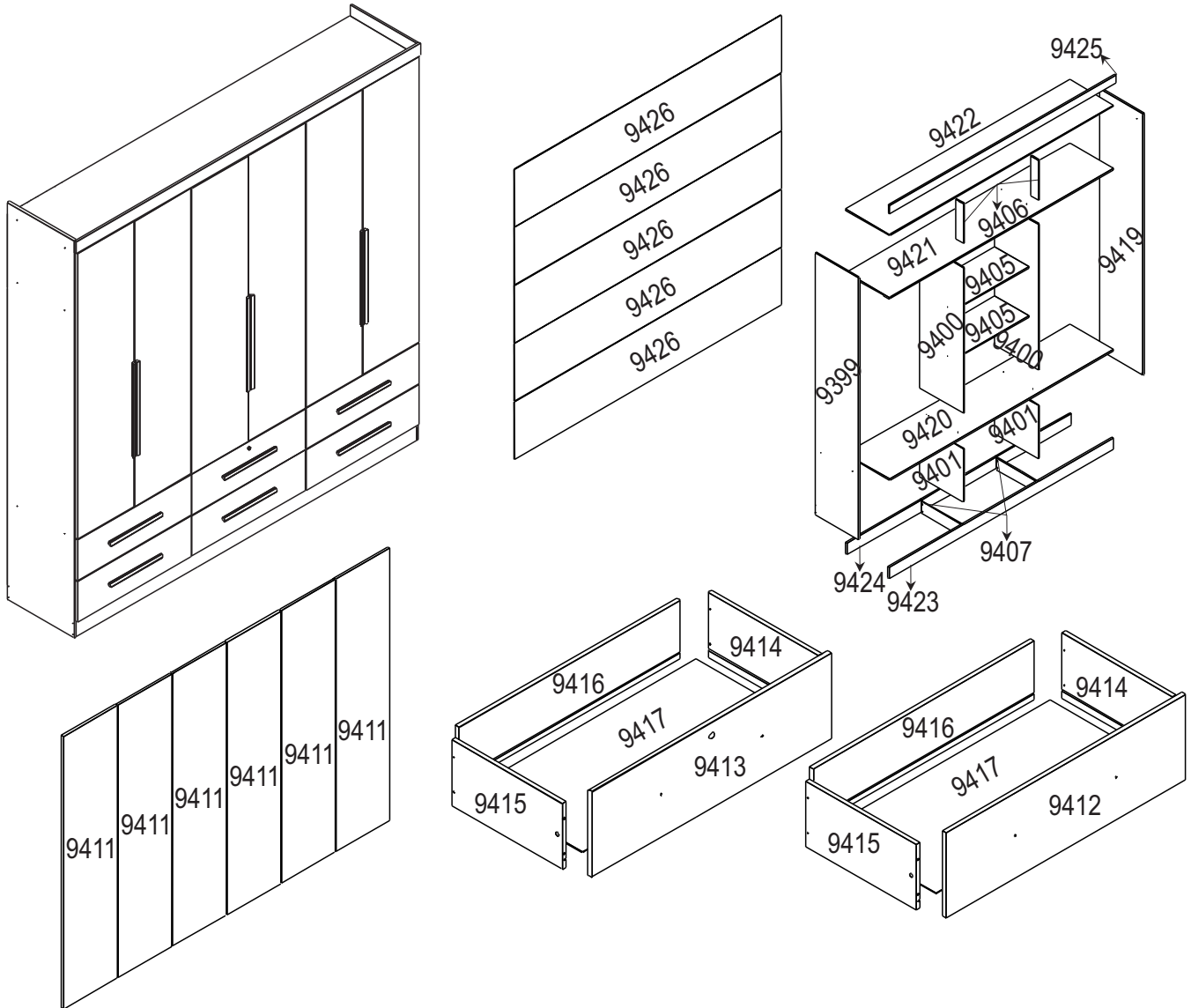





















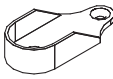

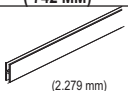
COD.	DESCRIÇÃO	DIVENSÃO=MM	QTD.	VOL.
9399	LATERAL ESQUERDA	445X2300X12	01	1/3
9400	LATERAL INTERNA	445X1282X12	01	1/3
9401	LATERAL DO GAVETEIRO	445X468X12	02	2/3
9405	PRATELEIRA	349X751X12	02	2/3
9406	BATENTE	80X350X12	02	2/3
9407	TRAVAMENTO DO RODAPÉ	98X414X12	02	2/3
9411	PORTA	378X1652X15	06	3/3
9412	FRENTE DE GAVETA	235X760X15	05	3/3
9413	FRENTE DE GAVETA COM CHAVE	235X760X15	01	3/3
9414	LATERAL DIREITA DE GAVETA	180X350X12	06	3/3
9415	LATERAL ESQUERDA DE GAVETA	180X350X12	06	2/3

COD.	DESCRIÇÃO	DIVENSÃO=MM	QTD.	VOL.
9416	CONTRA FUNDO	148X701X12	06	1/3
9417	FUNDO DE GAVETA	350X711X03	06	2/3
9419	LATERAL DIREITA	445X2300X12	01	1/3
9420	BASE INFERIOR	445X2277X12	01	2/3
9421	BASE DO IVALEIRO	445X2277X12	01	2/3
9422	BASE SUPERIOR	445X2277X12	01	2/3
9423	RODAPÉ	98X2277X15	01	1/3
9424	RODAPÉ TRASEIRO	98X2277X15	01	1/3
9425	MOLDURA	70X2301X15	01	1/3
9426	FUNDO TRASEIRO	430X2297X03	05	1/3

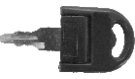

ESCANEE O QR CODE
E CONHEÇA NOSSA
LINHA DE PRODUTOS.

	accessories	accesorios	accessoires	acessórios
A66 (X40)		(4,0X40 CC)	A62 (X80)	 (3,5X25 CC)
A619 (X12)		(4,0X22 CC)	A362 (X04)	 (3,5X16 CC)
A54 (X140)		(3,5X12 CC)		

A114 (X32)		A92 (X03)		A580 (X06)	 (300 MM)	A608 (X02)	 (742 MM)
A129 (X120)	 (10x10)	A82 (X04)		A121 (X20)		A607 (X04)	 (2.279 mm)
A368 (X18)		A371 (X18)		A073 (X36)	 (6x30 MM)	A620 (X12)	
A617 (X02)		A615 (X01)		A616 (X01)		A382 (X01)	
A122 (X07)		A94 (X06)		A723 (X06)	 (380 M)	A724 (X06)	 (572 M)

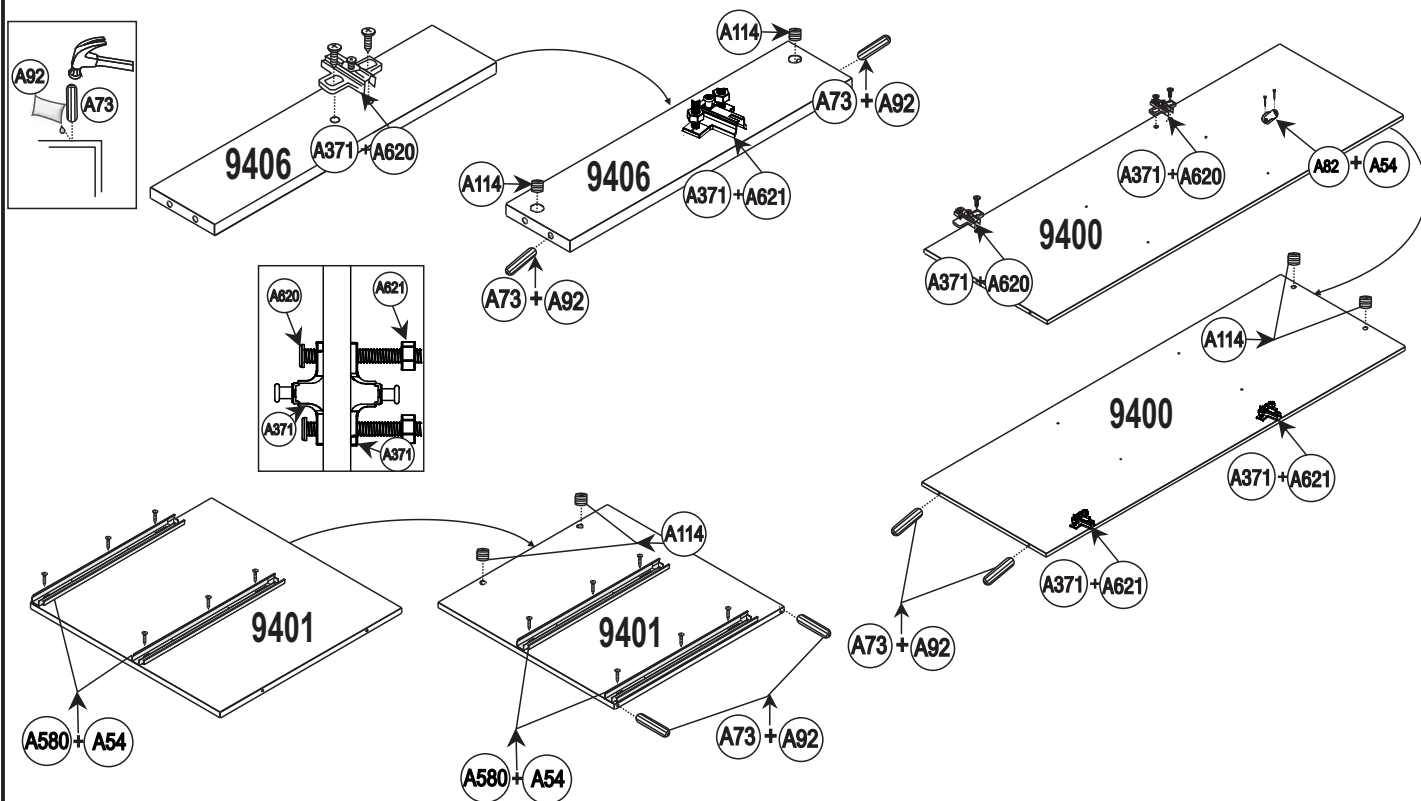

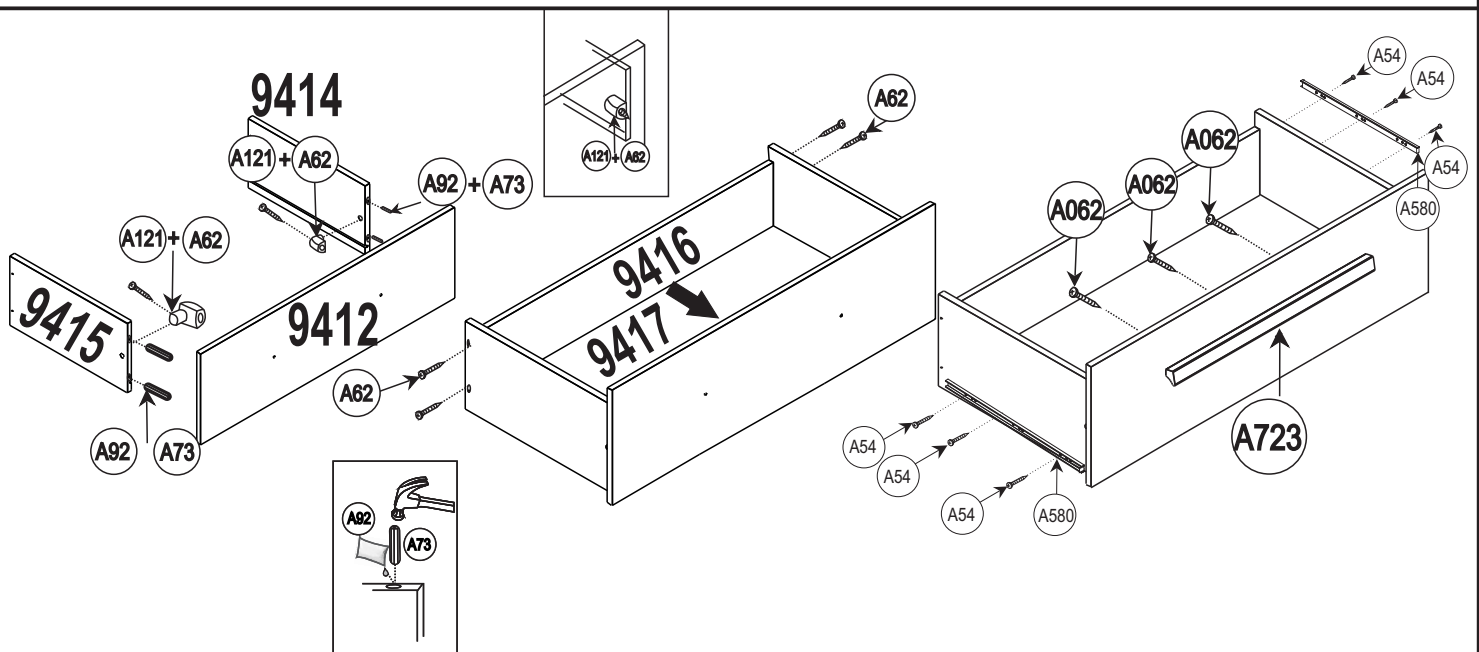
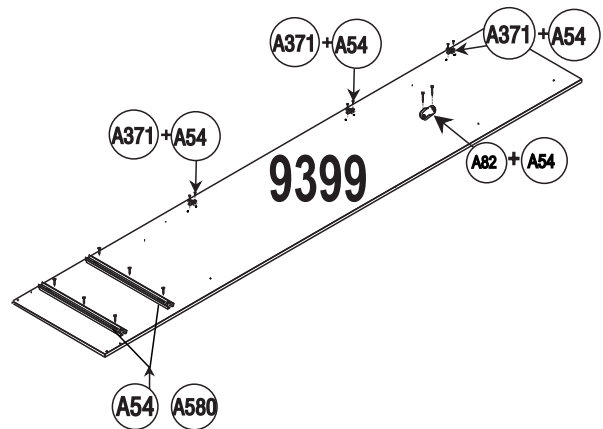
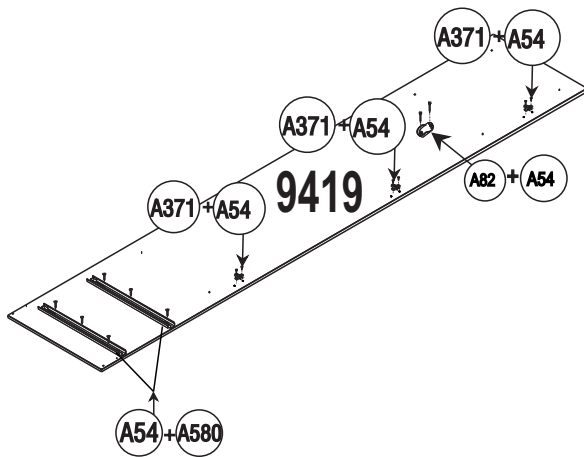
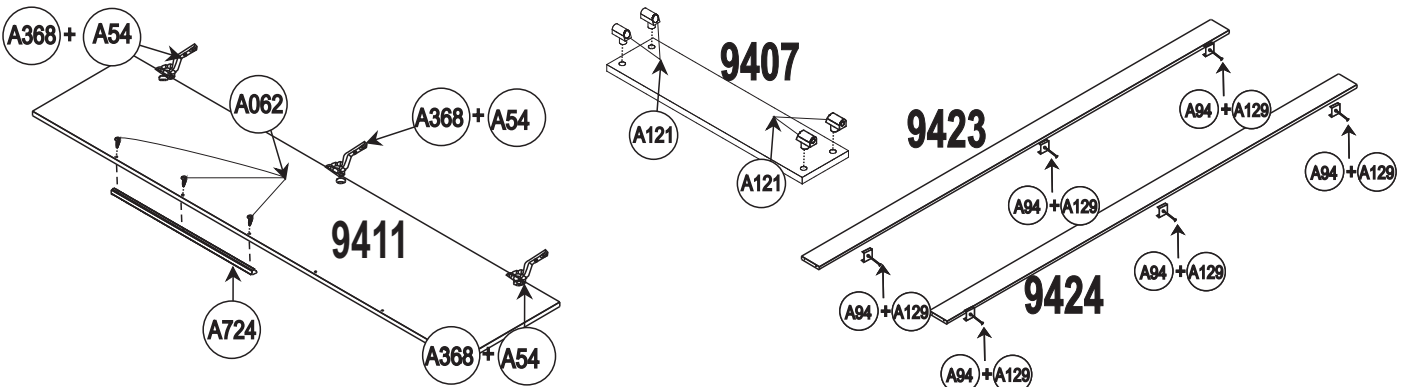
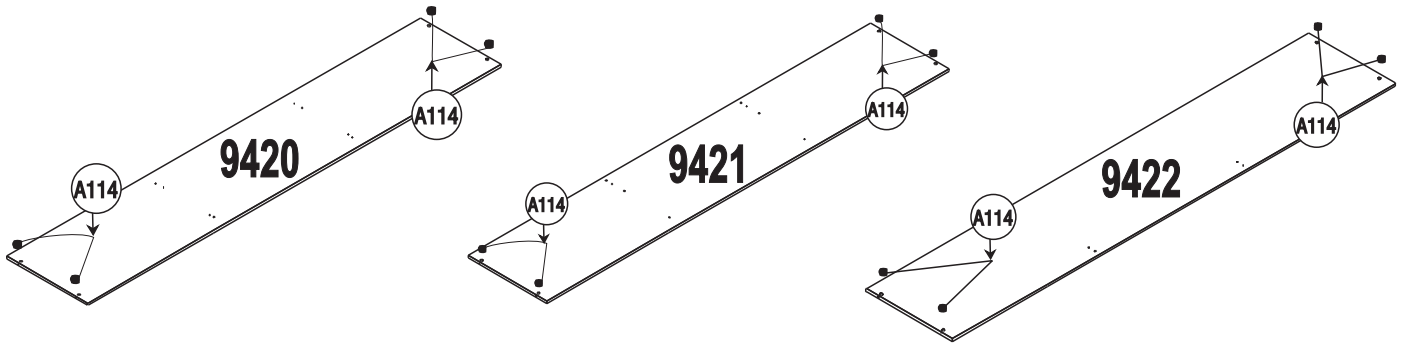

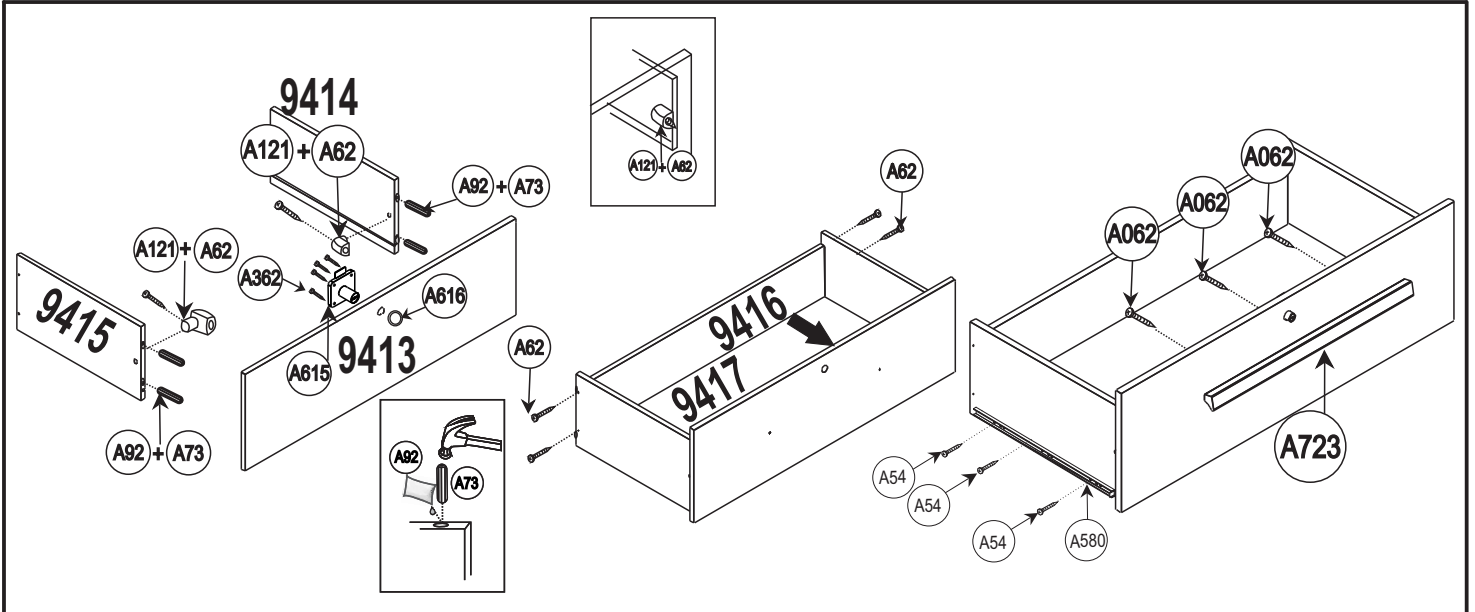

1°

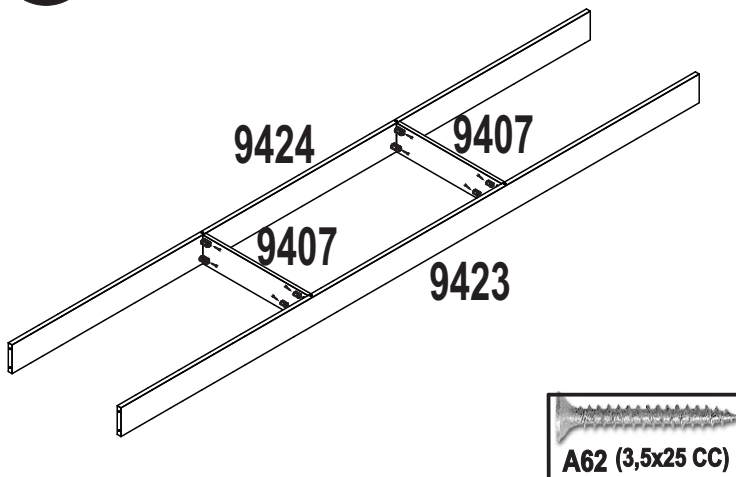

2°

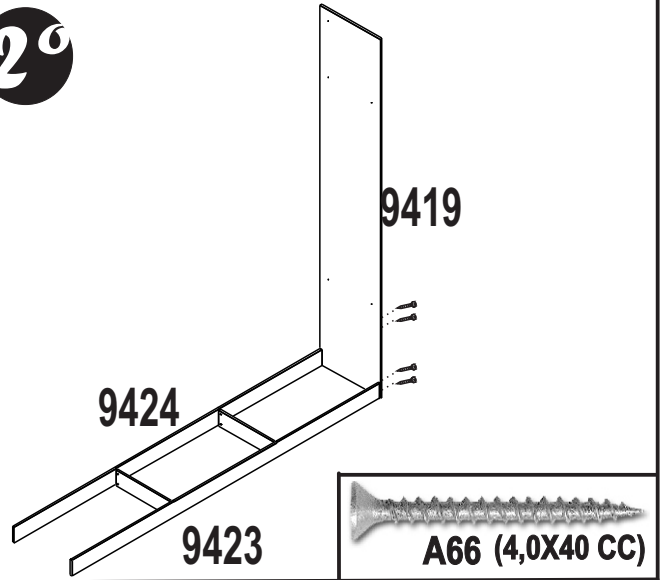

3°

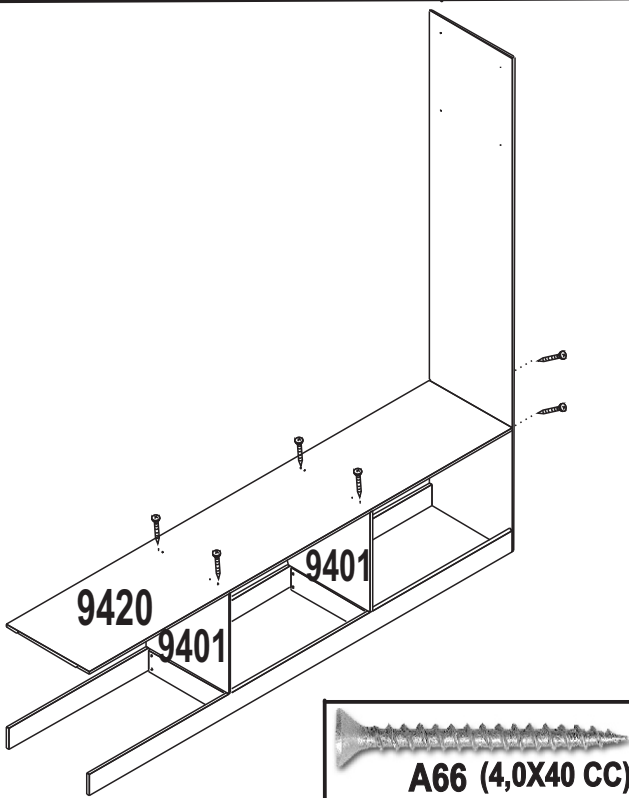

4°

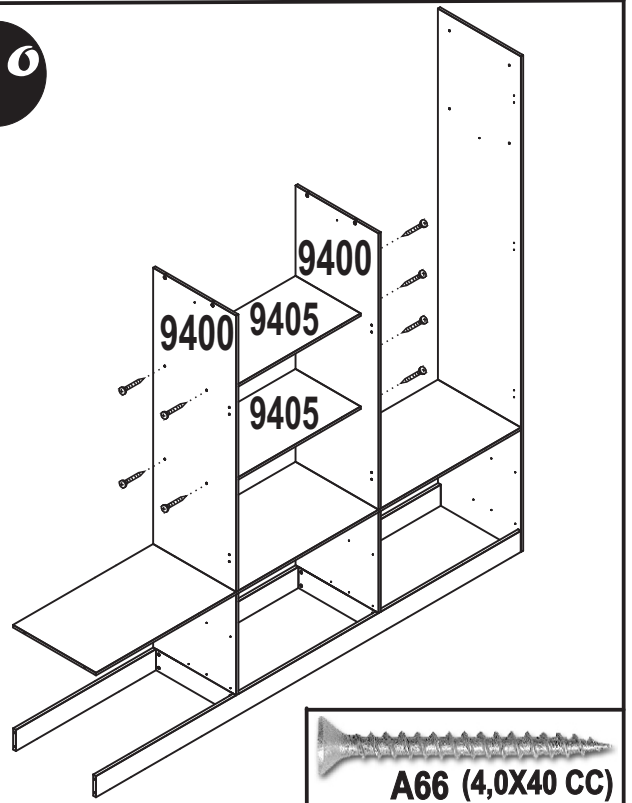

5°

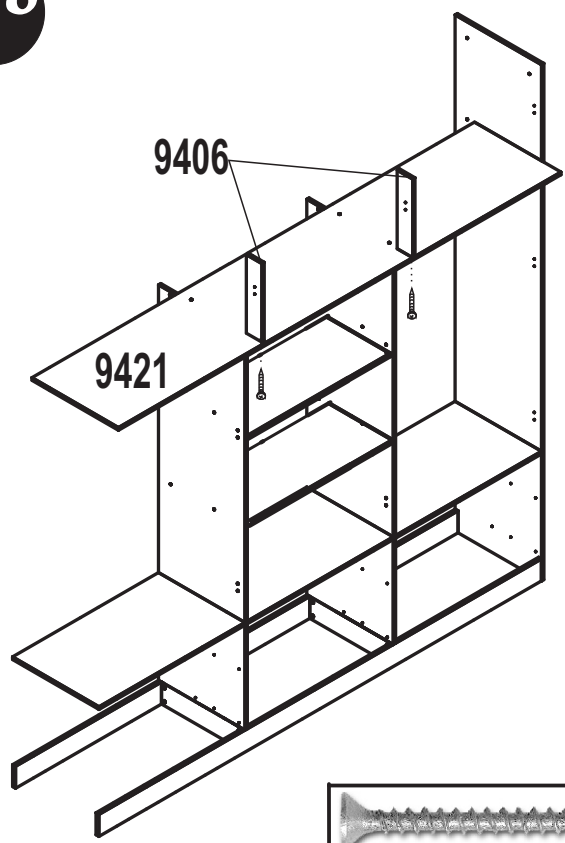

6°

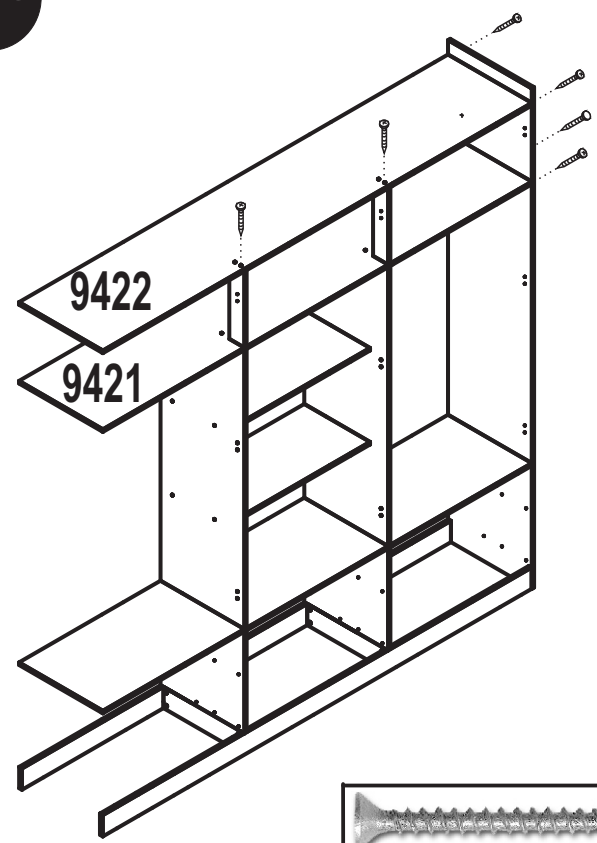

7°

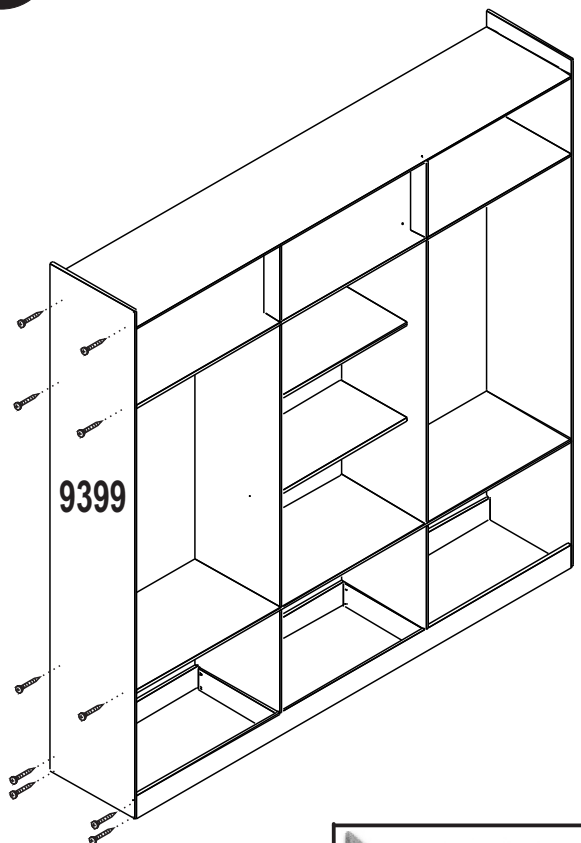

8°

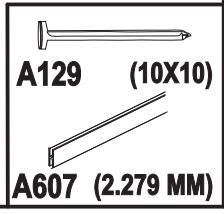
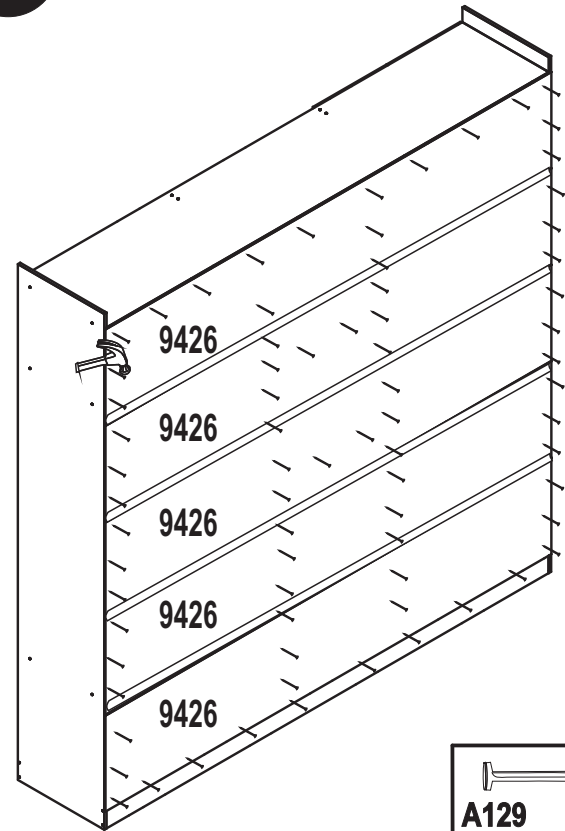

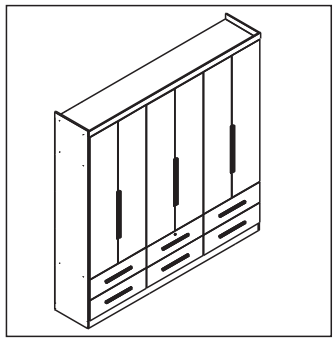
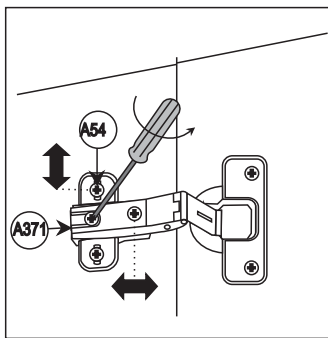
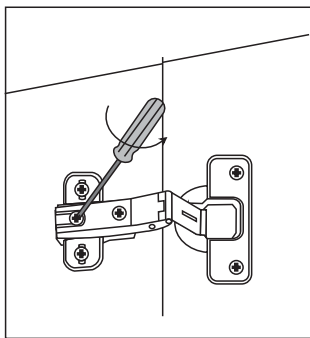
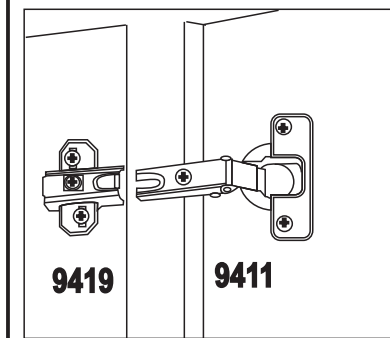
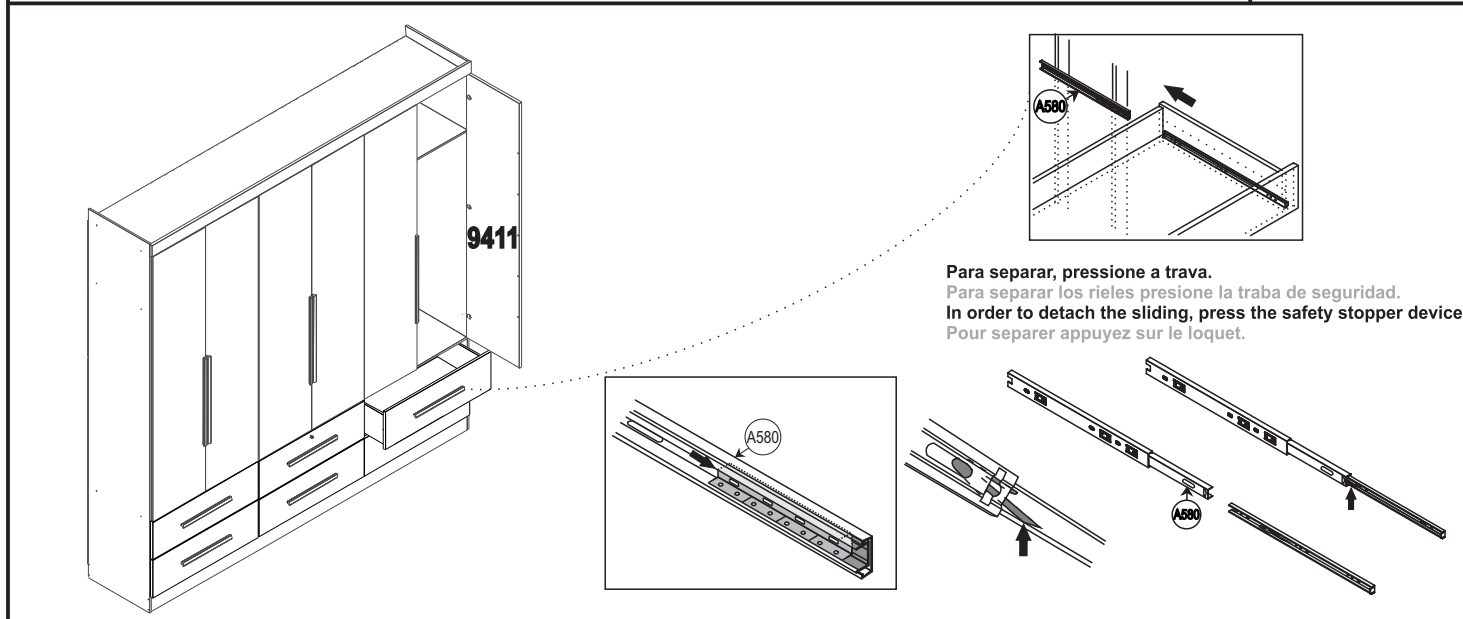
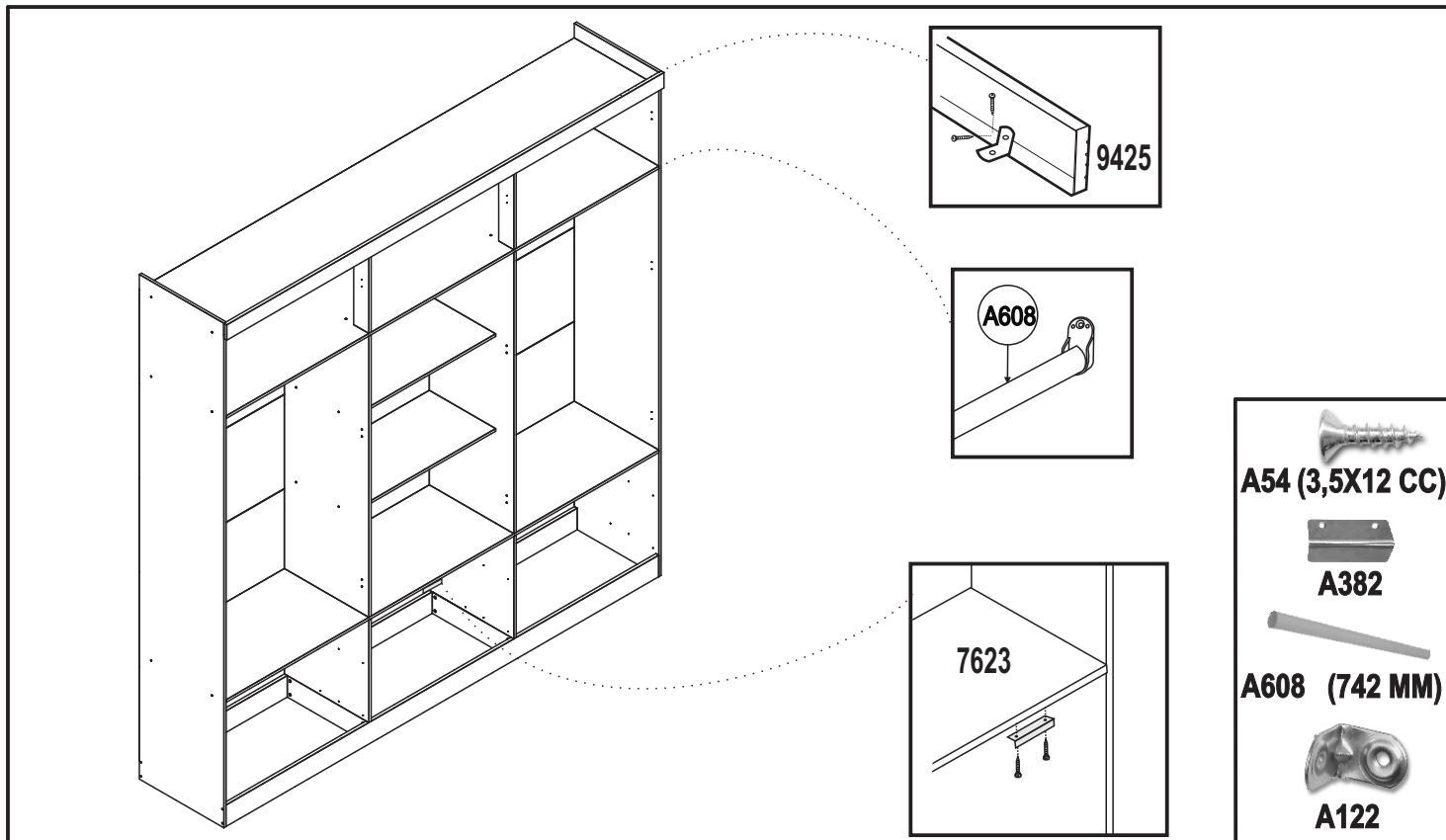

* Em caso de problemas técnicos com o móvel, favor informar o número de lote, número da op e data de fabricação, identificados nas etiquetas das caixas, para o rastreamento interno do produto e solução do problema.

* In case of technical problems with the product, please identify lot number, OP number and production date, located on the ticket boxes for Internal tracking and solution of the problem

* En caso de problemas tecnicos con el mueble, por favor informar el numero del lote, numero de la OP y fecha de producción, identificados en las etiquetas de las cajas, para el rastreamento interno del producto y solución del problema.



Agora que você já comprou o seu móvel, ele merece ser montado do jeito certo.

Erros de montagem causam mais de **60%** dos danos em móveis.

Por que contratar?

Tranquilidade do **início ao fim** da montagem



PROFISSIONAIS QUALIFICADOS

Especialistas certificados na **MadeiraMadeira Serviços**.



FERRAMENTAS PROFISSIONAIS

que **protegem** seus móveis.



AGENDAMENTO EM 24 HORAS

escolha a data e o turno **ideais para** você.



GARANTIA DE 3 MESES

de cobertura **completa**.

Mais de 1 MILHÃO DE MONTAGENS
★ com avaliação **4.7** ★

Mariana S., São Paulo

"Chegaram no horário e montaram tudo rapidamente. Serviço incrível!"



Carlos R., Belo Horizonte

"Tentei montar sozinho e foi um desastre. Com a **MadeiraMadeira Serviços** ficou perfeito."



Ana P., Rio de Janeiro

"Agendamento ágil e **montagem pontual e perfeita**. Recomendo demais!"



Agende agora pelo QR Code

Madeira**Madeira** Serviços · Atendimento em todo o Brasil



Escaneie o QRCode