

Linea Brasil

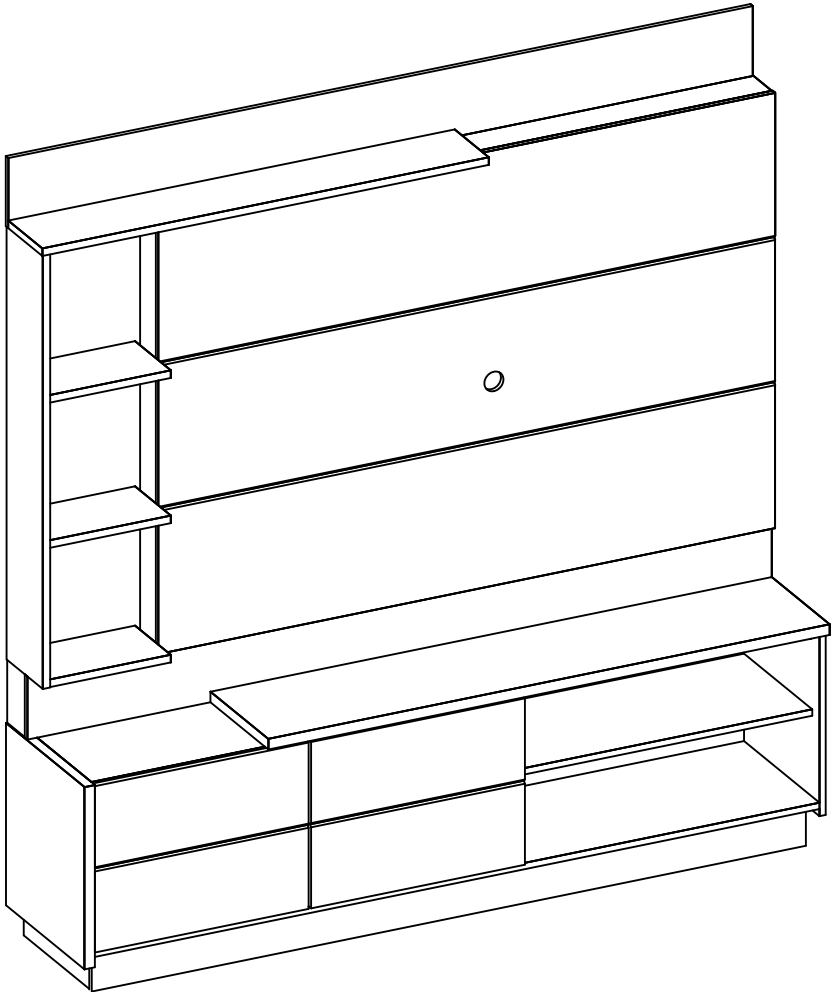

**HOME ATLANTA**

V-0 10/01/24

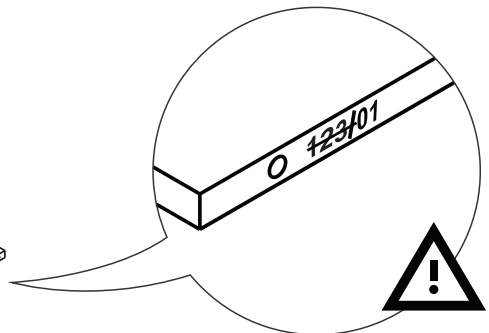
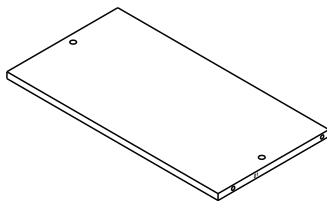
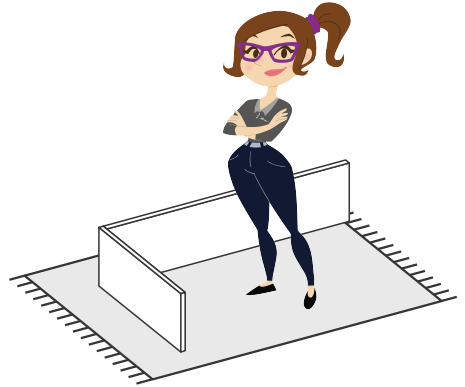
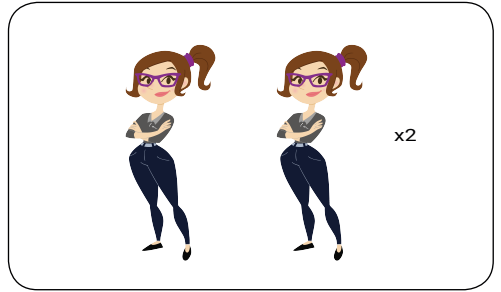
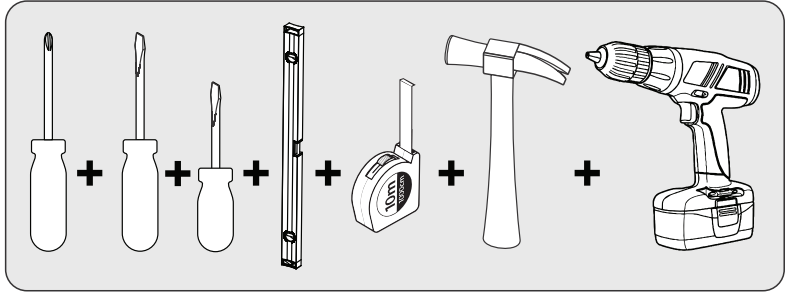
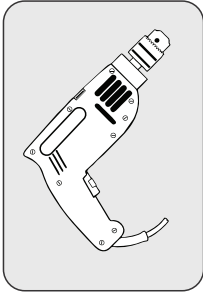

## GARANTIA / GARANTIA / WARRANTY

Nossos produtos são garantidos por 90 dias contra defeitos de fabricação. Ao constatar um problema coberto pela garantia, entre em contato com a loja onde o produto foi comprado. Ela estará capacitada para atendê-lo da melhor forma diante de cada caso. Reclamações de garantia somente poderão ser atendidas se o termo de garantia for apresentado no ato de reivindicação, acompanhado de sua nota fiscal de compra.

*Nuestros productos están garantidos contra defectos de fabricación por 90 días, a partir de la compra. Ao constatar un problema protegido por la garantía, póngase en contacto con la tienda donde se adquirió el producto. Ella estará capacitada para atenderlo de la mejor manera de acuerdo con cada caso.*

*Our products are guaranteed against manufacturing defects for 90 days from the date of purchase. When you find a problem covered by the warranty, please contact the store where the product was purchased. The store be able to serve you in the best way in each case.*

### Exclusões

- Desgaste natural ou danos causados por água, maresia, ferrugem, incêndio, calor, cupins e pragas em geral.
- Montagem, manutenção e uso inadequado.
- Não cumprimento das recomendações técnicas do esquema.
- Montagens e desmontagens após a primeira instalação.
- Instalações elétricas e outras afins.

### Exclusiones

- Desgaste natural o daños causados por agua, mares, maresia, incendios, calor, termitas y plagas en general.
- Montaje, mantenimiento y uso inadecuado.
- No cumplimiento de las recomendaciones técnicas del esquema.

### Exclusions

- Natural wear or damage caused by water, sea, rust, fire, heat, termites and plagues in general.
- Assembly, maintenance and improper use.
- Failure to comply with the technical recommendations of the assembly instructions.

### Importante

A Linha Brasil não autoriza nenhuma pessoa, loja ou entidade assumir em seu nome qualquer outra garantia que não conste no certificado. O fabricante reserva-se no direito de efetuar nos produtos eventuais modificações que considerar necessárias, sem prejudicar as características essenciais. Os produtos terão peças de assistência para reposição no período de 1 ano a contar de sua retirada do mercado, desde que haja matéria-prima equivalente, observando o dispositivo no Art.32 da Lei 8.078/90 (Cód. Defesa do Consumidor). O atendimento para produtos fora de linha é feito por programação especial, através da loja revendedora sob aprovação de consulta prévia ao fabricante.

### Importante

*Linea Brasil no autoriza a ninguna persona, tienda o entidad a asumir en su nombre cualquier otra garantía que no figure en el certificado. El fabricante se reserva el derecho de efectuar en los productos eventuales modificaciones que considere necesarias, sin perjudicar las características esenciales. Los productos tendrán piezas de asistencia para reposición en el período de 1 año a partir de su retirada del mercado. La atención para productos fuera de línea es hecha por programación especial, a través de la tienda revendedora bajo aprobación de consulta previa al fabricante.*

### Important

*Linea Brasil does not authorize any person, store or entity to assume on its behalf any other warranty that does not appear on the certificate. The manufacturer reserves the right to make in the products any modifications that it considers necessary without prejudice to the essential characteristics. The products will have replacement parts within one year of being withdrawn from the market. The service for off-line products is done by special programming, through the store reseller under prior consultation with the manufacturer.*

## INSTRUÇÕES DE LIMPEZA E CONSERVAÇÃO

### INSTRUCCIONES PARA LA LIMPIEZA E CONSERVACION / CLEAN AND PRESERVATION INSTRUCTURE

Para retirar o pó, utilize um pano seco, espanador ou aspirador. Se necessário, para uma limpeza mais efetiva, utilize um pano levemente umedecido com água. Finalize com uma flanela limpa e seca.

*Para eliminar el polvo, utilice un paño seco, mopa o la aspiradora. Si es necesario, para una limpieza más eficaz, utilice un paño ligeramente humedecido con agua. Terminar con un paño limpio y seco.*

*To take dirty, use a dry cloth, duster or vacuum. If necessary to take the dust, use a wet cloth. Finish with a clean and dry flannel.*

### IMPORTANTE / IMPORTANTE / IMPORTANT

- ⊗ Não utilize produtos abrasivos como álcool e detergentes, como também esponjas rígidas ou palha de aço na limpeza dos móveis. *No use limpiadores abrasivos como alcohol y detergentes, así como esponjas rígidas lana de acero para limpiar los muebles. Do not use abrasives such as alcohol and detergent, tough soaker also steel wool to clean the furniture.*

Proteja a superfície do móvel de objetos que transmitam calor ou umidade. *Proteja la superficie del mueble de objetos que transmitan calor o humedad. Protect the surface of the furniture against objects that can pass heat and humidity.*

Evitar o contato de água e produto de limpeza com o rodapé do produto, pois poderá danificá-lo. *Evitar el contacto con agua y producto de limpieza con el rodapé del producto, pues podrá dañarlo. Avoid the contact of water and cleaning products with baseboard, cause it should damage your product.*

Procure sempre utilizar flanela limpa e seca para a limpeza. *Busque siempre utilizar flanela limpia y seca para la limpieza. Try always to use a clean and dry flannel to cleaning.*

Cuidado com objetos pontiagudos, eles podem arranhar a superfície das portas e tampo. *Cuidado con objetos afilados, ellos pueden rayar la superficie de las puertas e la tapa. Take care with sharp objects, they can scratch the door lid surface.*

## Imagem Ilustrativa/ Illustrative Image/ Imagen Ilustrativa

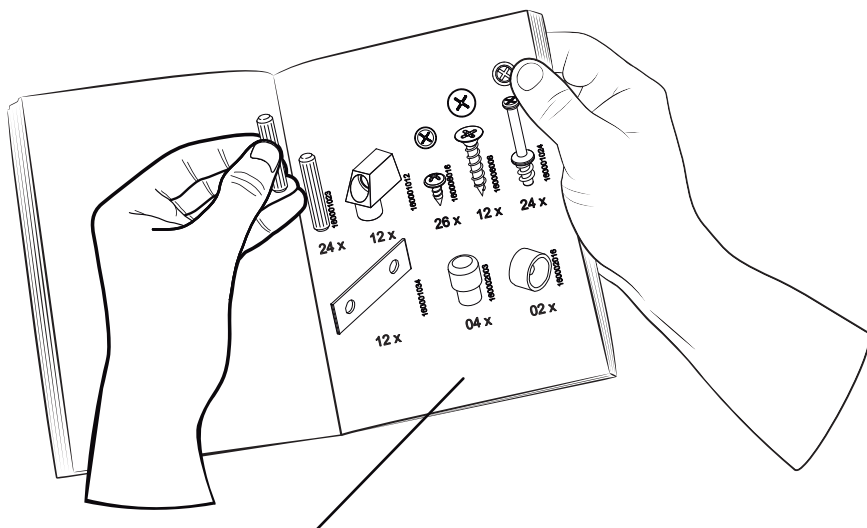

### Preste Atenção! ¡Preste atención! Attention!



As ferragens dos nossos manuais são sempre apresentadas nas mesmas proporções da peça na vida real.  
Caso apareça alguma dúvida no decorrer do processo de montagem, coloque a ferragem ao lado do desenho e faça a consulta :D

Los accesorios de nuestros manuales siempre se presentan en las mismas proporciones que la pieza en la vida real.  
Si tiene alguna duda durante el proceso de montaje, coloque los accesorios junto al dibujo y haga una consulta :D

The accessories in our manuals are always presented in the same proportions as the spare part in real life.  
If you have any questions during the assembly process, place the accessory next to the drawing and make an inquiry :D

### Símbolos: Símbolos: Symbols:



- + Parafuso Phillips
- Parafuso Fenda
- ⊗ Parafuso Allen

- + Tomillo Phillips
- Tomillo Ranurado
- ⊗ Tomillo Allen

- + Phillips screw
- Slotted Screw
- ⊗ Allenscrew

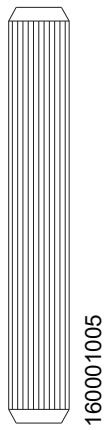

160001005

03x



160001023

49x

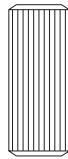

160001003

02x

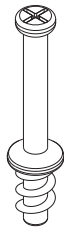

160001024

26x

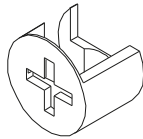

160001025

32x

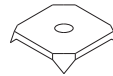

160001002

12x

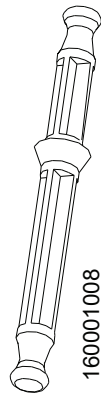

160001008

03x

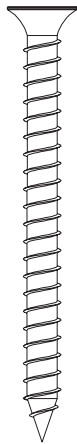

160006010

07x



160006006

20x

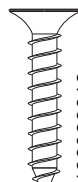

160006018

39x



160006016

204x



160006001

04x



160006011

90x

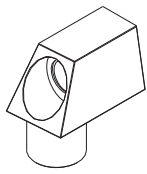

160001012

06x

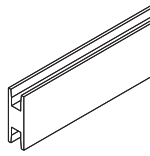

160011073

01x

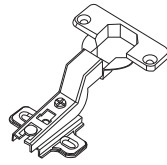

160003012

02x

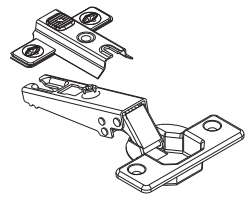

160003003

02x



160002005

01x



160002012

02x

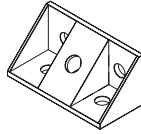

160001018

22x

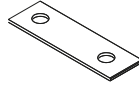

160001034

16x

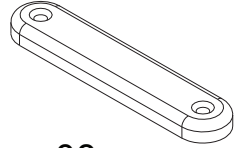

160002004

08x



160001061

28x



160001022

07x

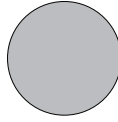

160002002

20x



160001032

06x

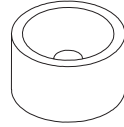

160002016

01x

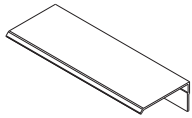

160005053

02x



160002015

02x

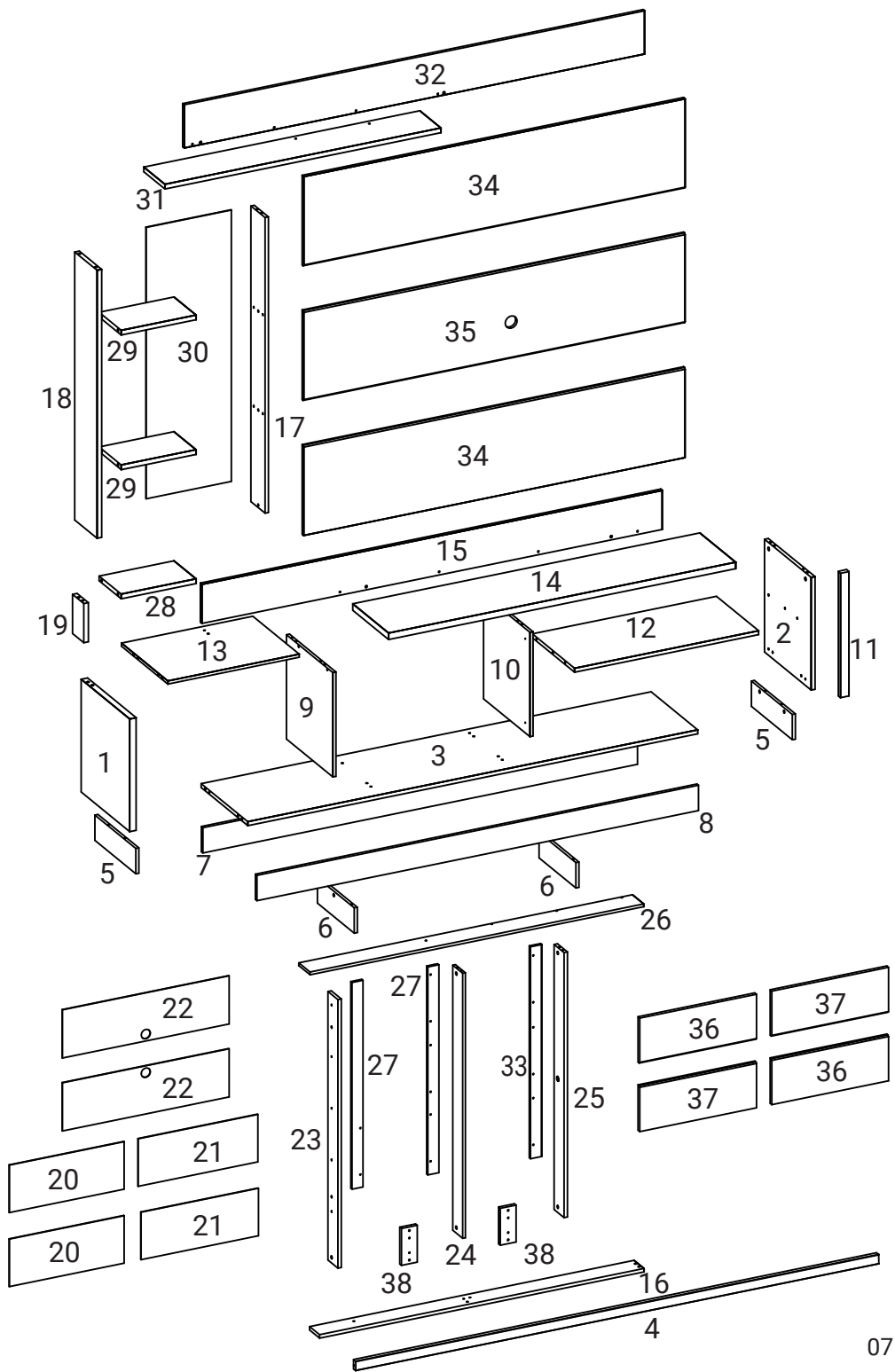

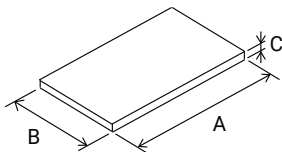

VOLUME Caja BOX	ITEM Artículo Item	PEÇA Pieza Part	DESCRIÇÃO Descripción Description	DIMENSÕES (mm) Dimensión/Dimension			QUANTIDADE Cantidad Amount	Material
				A	B	C		
1	1	510378001	LATERAL ESQUERDA	432	380	25	1	MDP
1	2	510378002	LATERAL DIREITA	432	365	15	1	MDP
1	3	510378003	BASE	1760	365	15	1	MDP
1	4	510378004	ENCABECAMENTO BASE	1744	31	15	1	MDF
2	5	510378005	RODAPE LATERAL	320	97	12	2	MDP
1	6	510378006	RODAPE CENTRAL	288	97	12	2	MDP
1	7	510378007	RODAPE TRASEIRO	1700	97	12	1	MDP
1	8	510378008	RODAPE FRONTAL	1728	97	12	1	MDP
1	9	510378009	DIVISAO ESQUERDA	400	363	12	1	MDP
1	10	510378010	DIVISAO DIREITA	400	363	12	1	MDP
1	11	510378011	ENCABECAMENTO LATERAL DIREITO	432	31	15	1	MDF
2	12	510378012	PRATELEIRA BALCAO	720	330	15	1	MDP
1	13	510378013	TAMPO ESQUERDO	514	363	12	1	MDP
1	14	510378014	TAMPO TV	1358	280	25	1	MDP
1	15	510378015	PAINEL INFERIOR	1801	150	12	1	MDP
1	16	510378016	TRAVESSA TRASEIRA APOIO TAMPO	1437	88	15	1	MDP
2	17	510378017	LATERAL DIREITA NICH0	1027	100	12	1	MDP
2	18	510378018	LATERAL ESQUERDA NICH0	1027	175	18	1	MDF
2	19	510378019	APOIO LATERAL ESQUERDO	150	88	18	1	MDP
2	20	510378020	FUNDO LATERAL ESQUERDO	530	209	2,8	2	MDF
2	21	510378021	FUNDO CENTRAL	514	209	2,8	2	MDF
1	22	510378022	FUNDO LATERAL DIREITO(COM FURO)	738	209	2,8	2	MDF
1	23	510378023	TRAVESSA ESQUERDA	1165	87	15	1	MDP
2	24	510378024	TRAVESSA CENTRAL	1150	88	12	1	MDP
1	25	510378025	TRAVESSA DIREITA	1150	88	15	1	MDP
1	26	510378026	TRAVESSA SUPERIOR	1478	100	12	1	MDP
2	27	510378027	TRAVESSA ESQUERDA APOIO PAINEL	1015	55	12	2	MDP
2	28	510378028	BASE NICH0	291	173	18	1	MDF
2	29	510378029	PRATELEIRA NICH0	291	173	18	2	MDF
2	30	510378030	FUNDO NICH0(COM FURO)	1040	331	2,8	1	MDF
2	31	510378031	PRATELEIRA SUPERIOR	1080	165	18	1	MDF
1	32	510378032	PAINEL SUPERIOR	1799	165	12	1	MDP
2	33	510378033	TRAVESSA DIREITA APOIO PAINEL	1015	54	12	1	MDP
2	34	510378034	PAINEL TV SUPERIO INFERIOR	1492	345	12	2	MDP
2	35	510378035	PAINEL TV CENTRAL	1492	345	12	1	MDP
1	36	510378036	PORTA ESQUERDA INFERIOR/DIREITA SUPERIOR	517	197	15	2	MDP
1	37	510378037	PORTA DIREITA INFERIOR/ESQUERDA SUPERIOR	517	197	15	2	MDP
1	38	510378038	APOIO PAINEL	160	70	15	2	MDP



ARTÍCULO	DESCRIPCIÓN
1	IZQUIERDA
2	DERECHA
3	BASE
4	RUMO BASE
5	PIE LATERAL
6	PIE CENTRAL
7	PIE TRASERO
8	PIE DELANTERO
9	DIVISIÓN IZQUIERDA
10	DIVISIÓN DERECHA
11	DIRECCIÓN DEL LADO DERECHO
12	ESTANTE DEL MOSTRADOR
13	ARRIBA A LA IZQUIERDA
14	TV ARRIBA
15	PANEL INFERIOR
16	PORTE SUPERIOR DEL SOPORTE DE CARRERA TRASERO
17	NICHO DEL LADO DERECHO
18	NICHO DEL LADO IZQUIERDO
19	SOPORTE LATERAL IZQUIERDO
20	LADO INFERIOR IZQUIERDO
21	FONDO CENTRAL
22	LADO INFERIOR DERECHO (CON AGUJERO)
23	BANDEJA IZQUIERDA
24	BANDEJA CENTRAL
25	VIAJE CORRECTO
26	BANDEJA SUPERIOR
27	PANEL DE SOPORTE DE VIAJE IZQUIERDO
28	BASE DE NICHO
29	ESTANTE NICHO
30	FONDO DE NICHO (CON AGUJERO)
31	ESTANTE SUPERIOR
32	PANEL SUPERIOR
33	PANEL DE SOPORTE DE VIAJE DERECHO
34	PANEL DE TV SUPERIOR INFERIOR
35	PANEL DE TV CENTRAL
36	PUERTA INFERIOR IZQUIERDA/SUPERIOR DERECHA
37	PUERTA INFERIOR DERECHA/SUPERIOR IZQUIERDA
38	SOPORTE DE PANELES

ITEM	DESCRIPTION
1	LEFT SIDE
2	RIGHT SIDE
3	BASIS
4	BASE RUMO
5	SIDE FOOT
6	CENTER FOOT
7	BACK FOOTER
8	FRONT FOOT
9	LEFT DIVISION
10	RIGHT DIVISION
11	RIGHT SIDE STEERING
12	COUNTER SHELF
13	TOP LEFT
14	TV TOP
15	BOTTOM PANEL
16	TOP OF THE REAR TRAVEL SUPPORT
17	RIGHT SIDE NICHE
18	LEFT SIDE NICHE
19	LEFT SIDE SUPPORT
20	BOTTOM LEFT SIDE
21	CENTRAL FUND
22	LOWER RIGHT SIDE (WITH HOLE)
23	LEFT TRAY
24	CENTER TRAY
25	RIGHT TRAVEL
26	TOP TRAY
27	LEFT TRAVEL SUPPORT PANEL
28	NICHE BASIS
29	NICHE SHELF
30	NICHE BOTTOM (WITH HOLE)
31	TOP SHELF
32	TOP PANEL
33	RIGHT TRAVEL SUPPORT PANEL
34	TOP LOWER TV PANEL
35	CENTER TV PANEL
36	LOWER LEFT/TOP RIGHT DOOR
37	LOWER RIGHT/TOP LEFT DOOR
38	PANEL SUPPORT

# 01

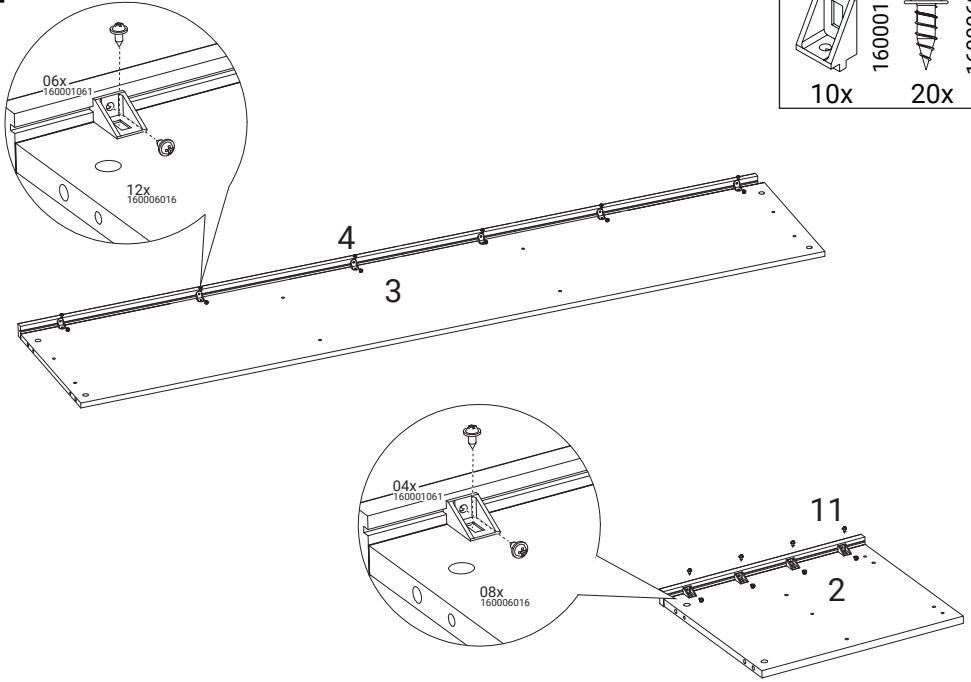
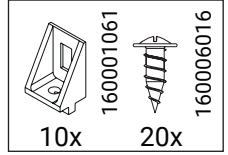

# 02

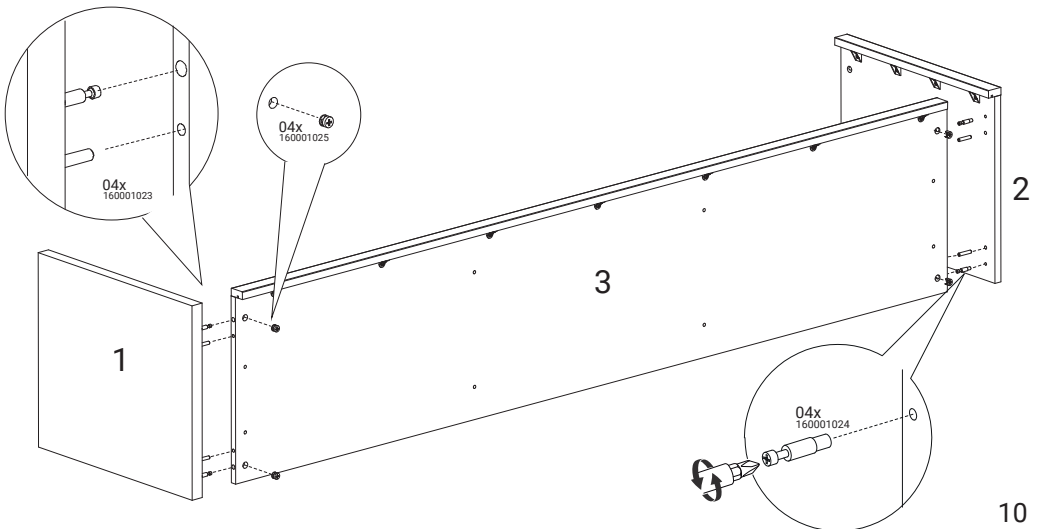
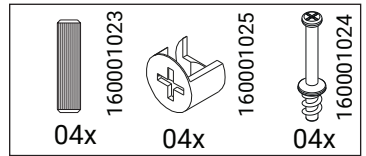

10

# 03

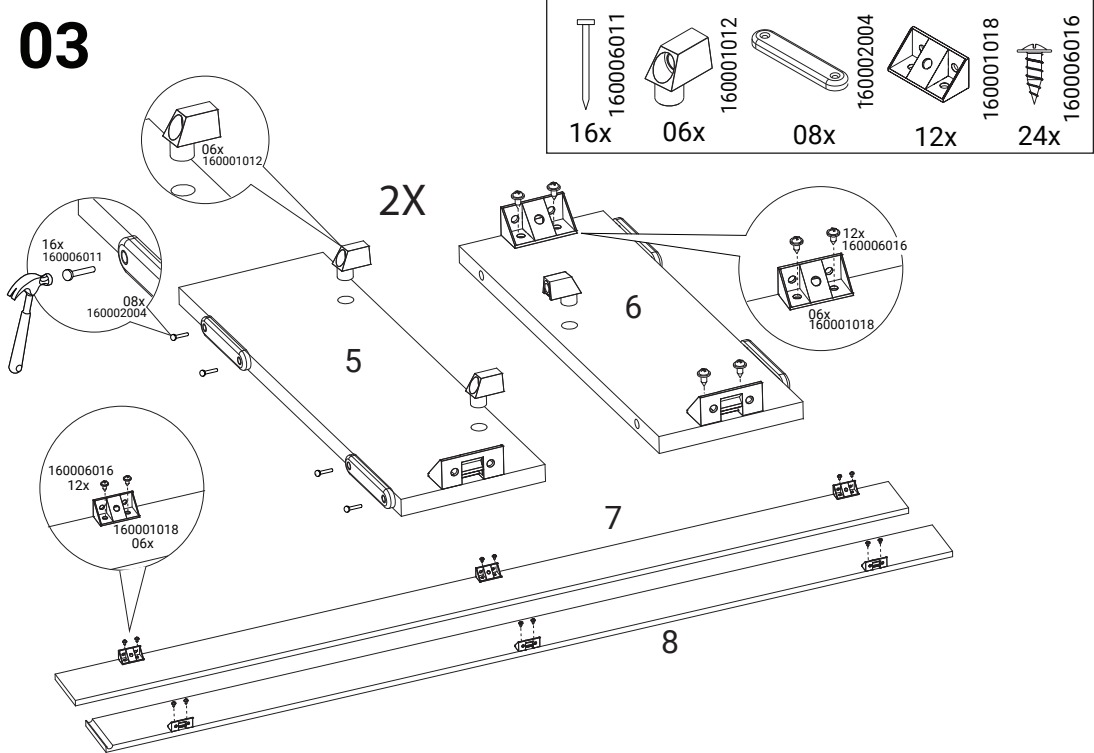

# 04

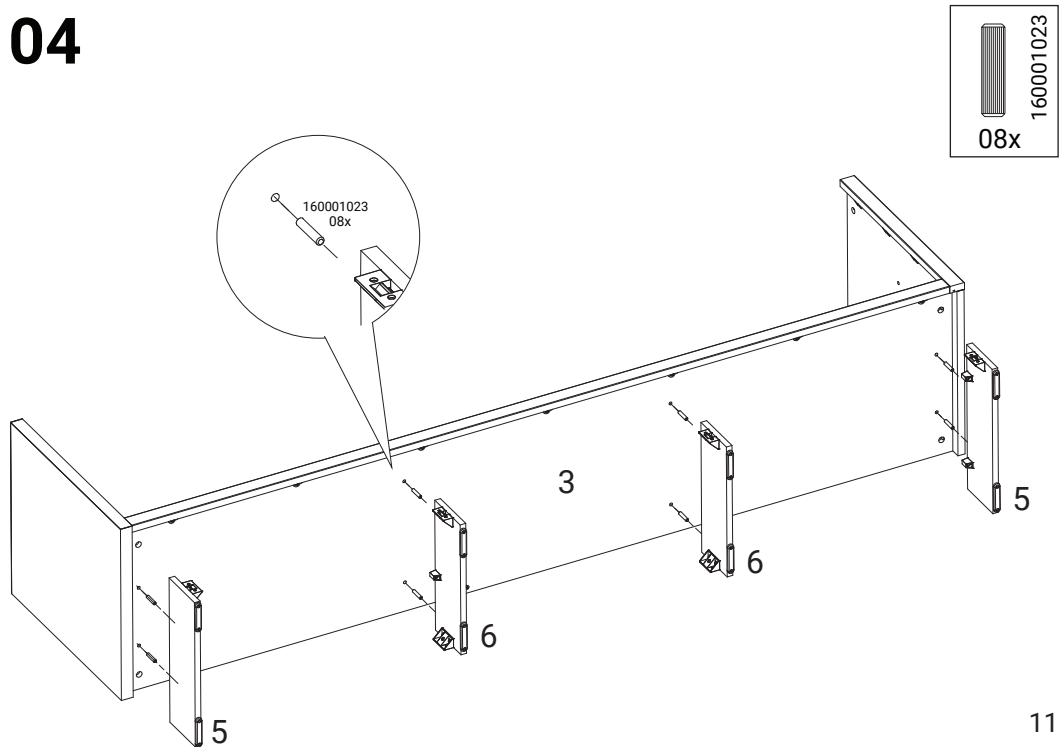

# 05

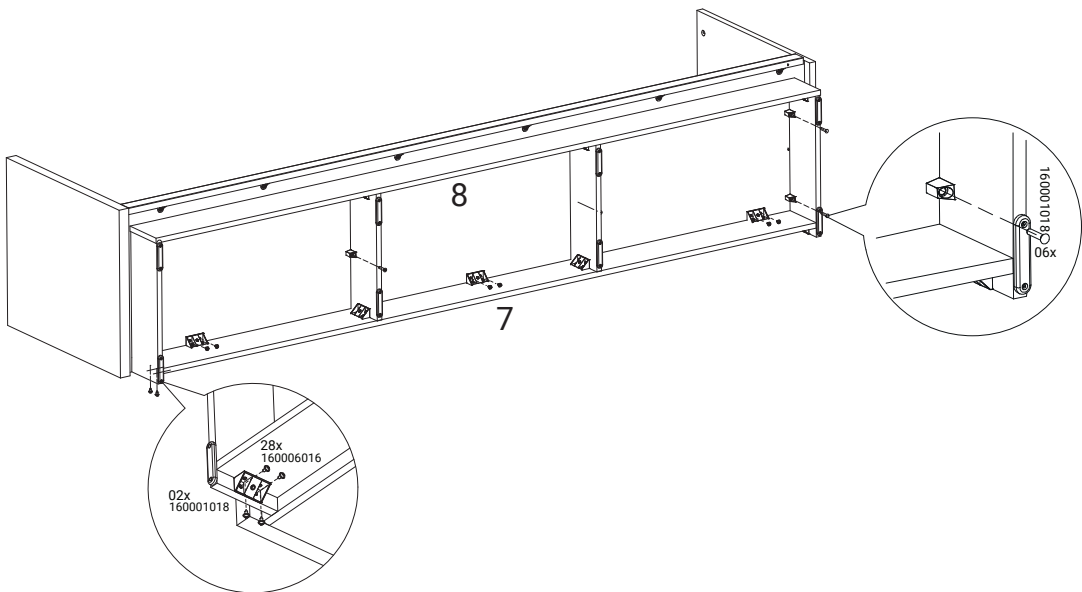
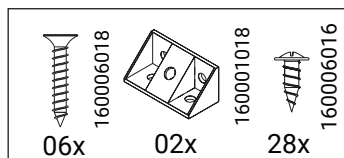

# 06

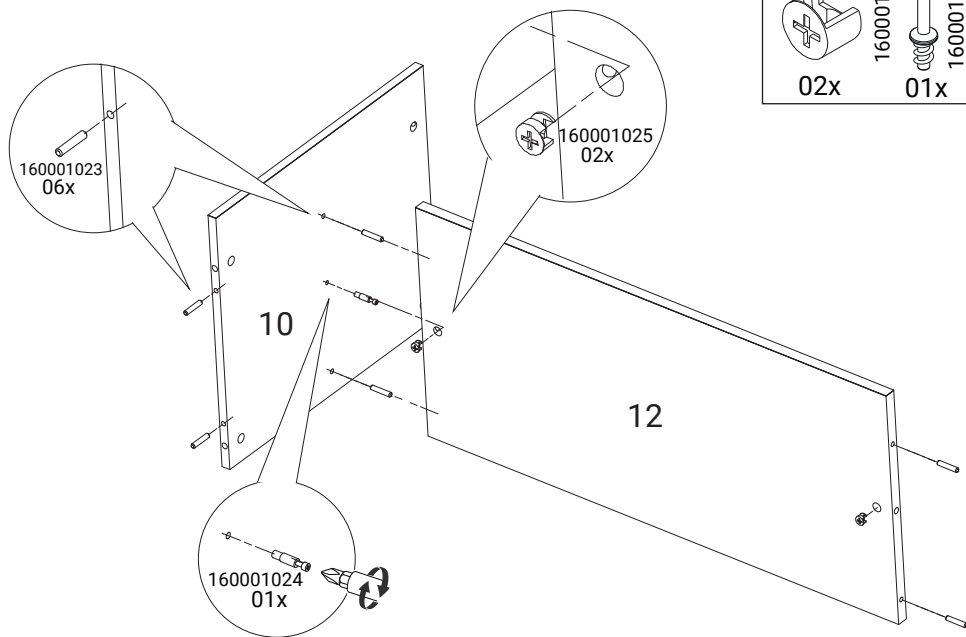
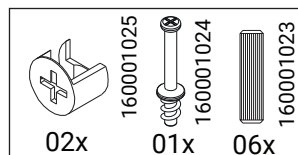

# 07

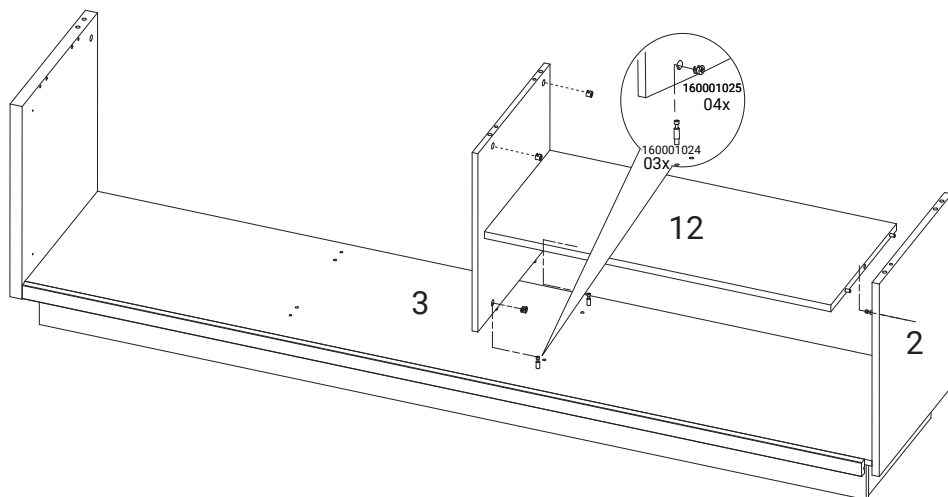
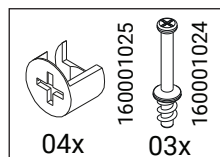

# 08

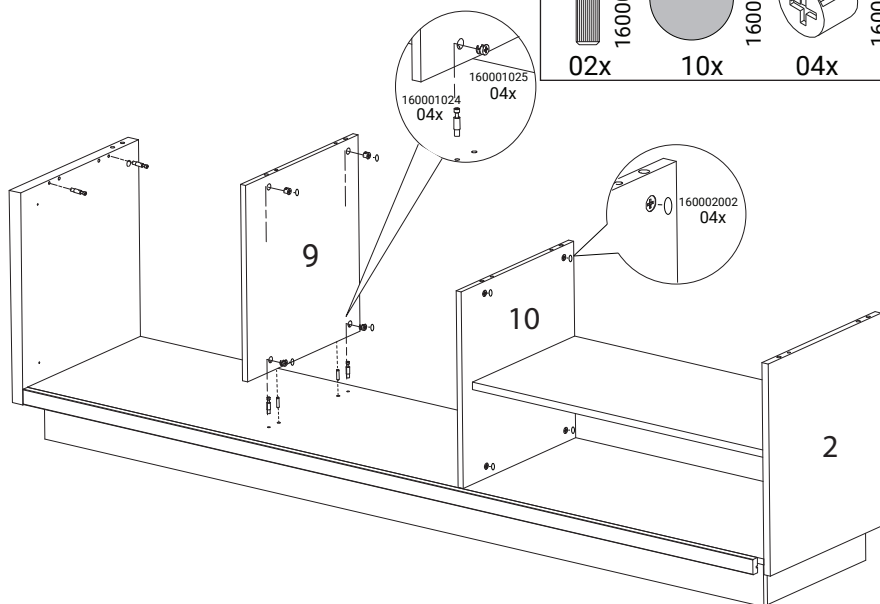
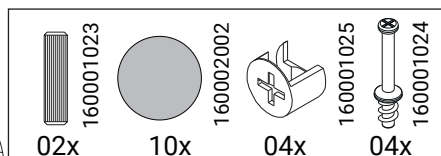

# 09

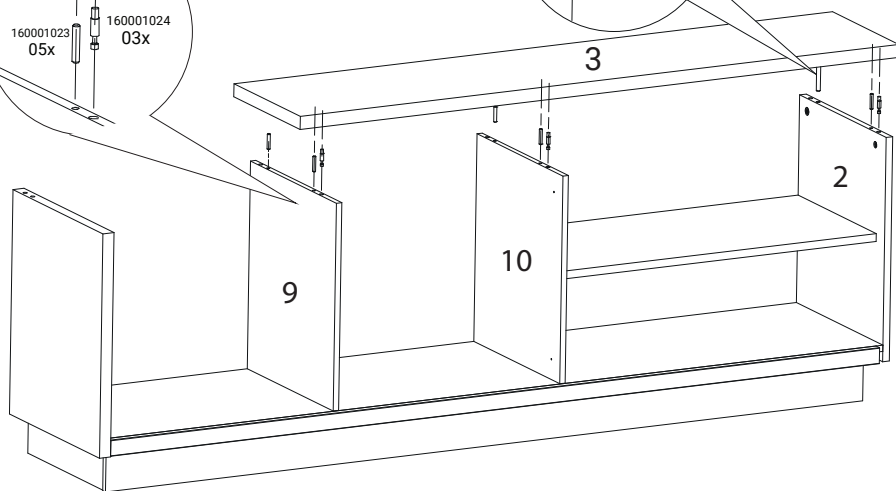
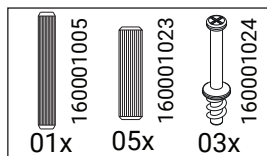
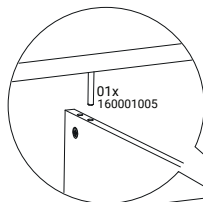
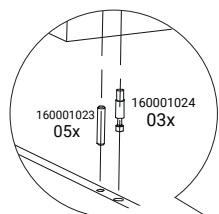

# 10

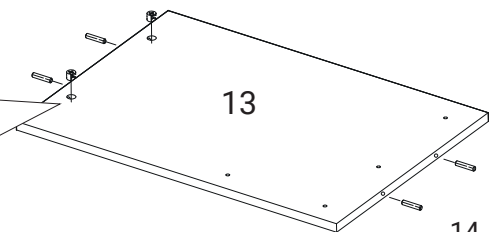
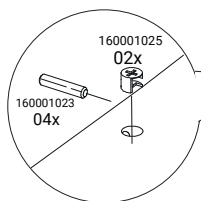
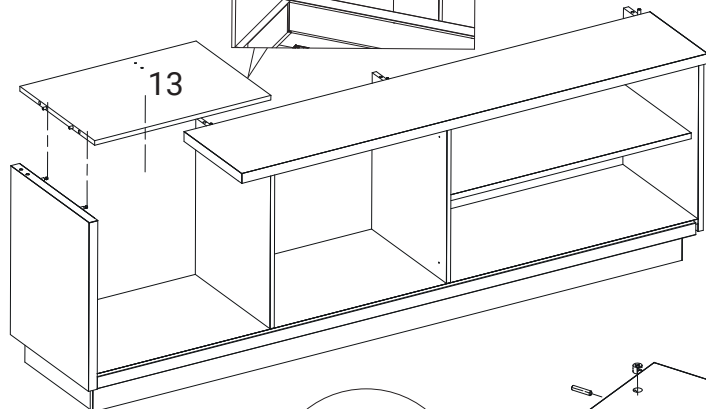
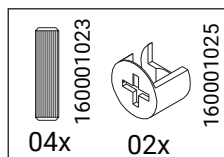
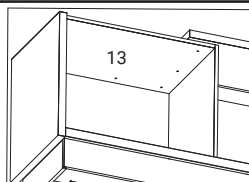

# 11

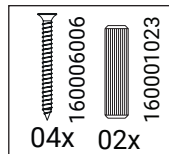
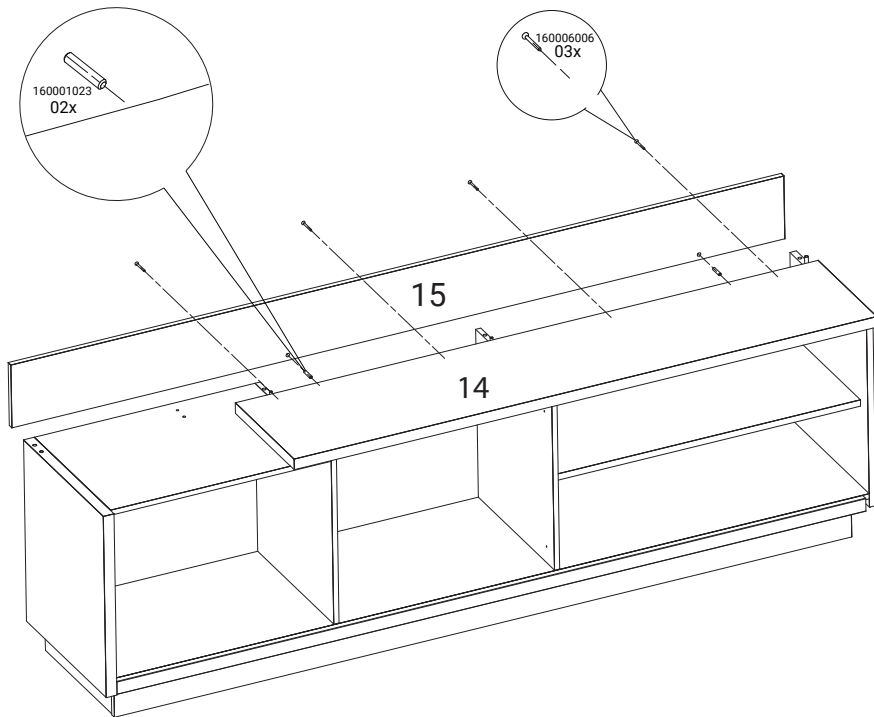

# 12

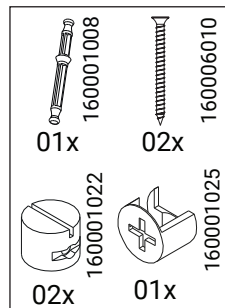
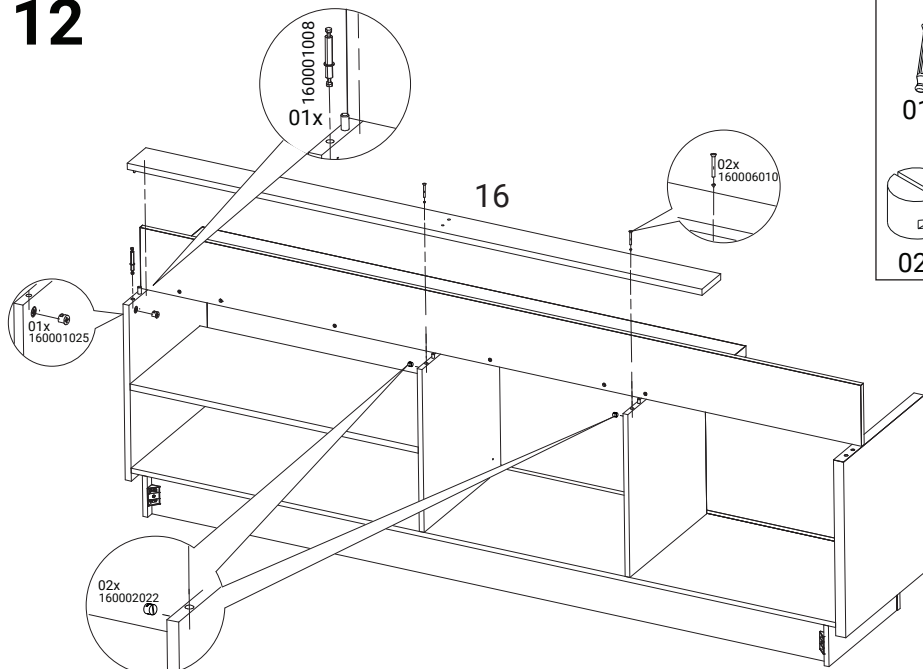

# 13

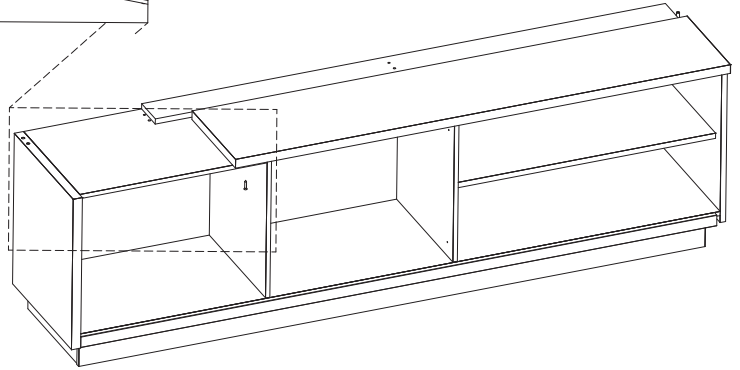
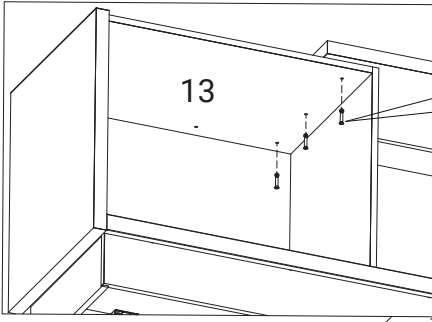
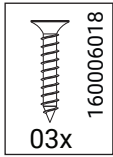



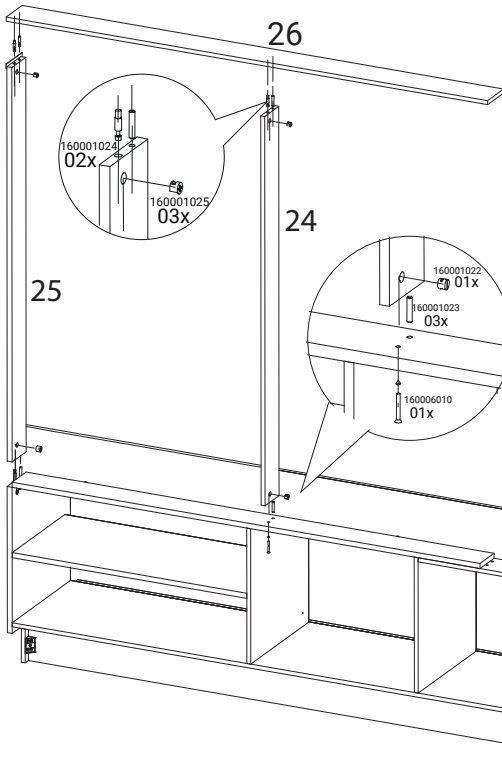
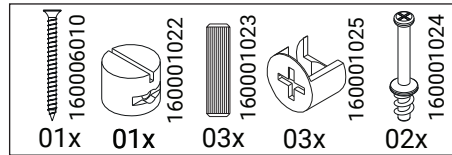



# 14



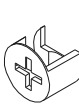

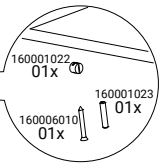
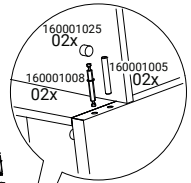
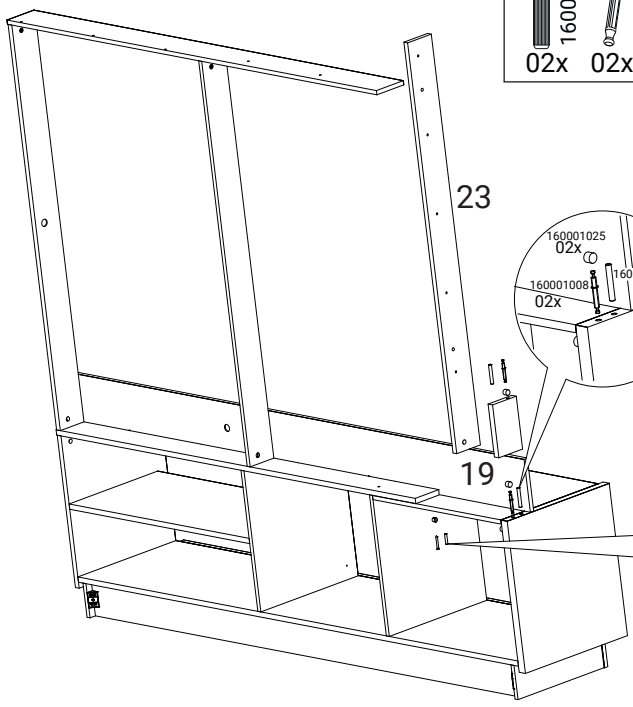

# 15

-   
 160001005  
 02x
-   
 160001008  
 02x
-   
 160001025  
 02x
-   
 160006010  
 01x
-   
 160001022  
 01x
-   
 160001023  
 01x



# 16

-   
 160006006  
 06x
-   
 160001061  
 18x
-   
 160006016  
 36x

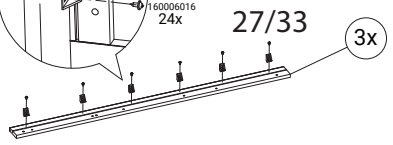
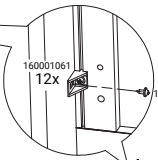
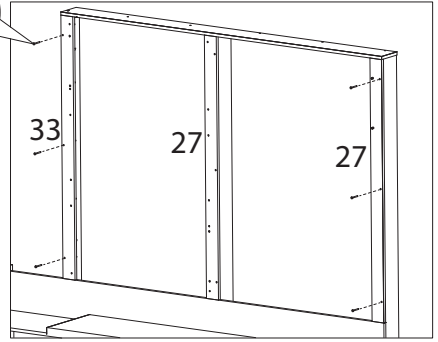
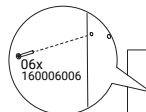
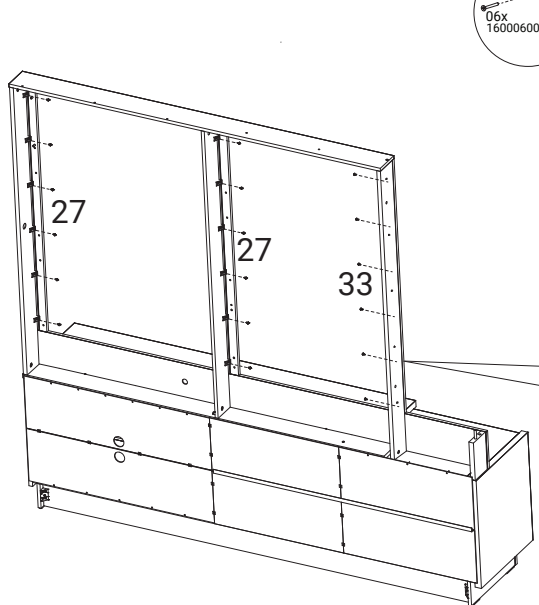

# 17

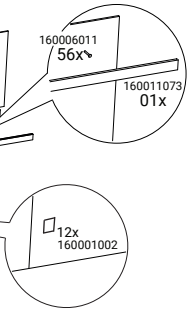
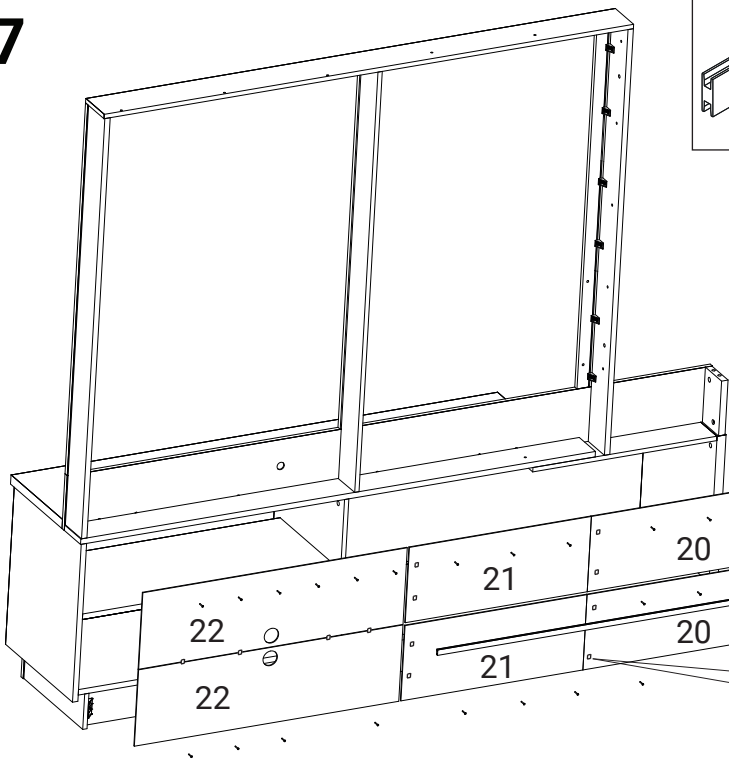
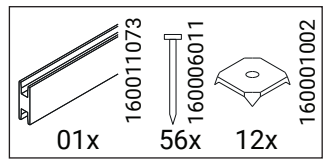

# 18

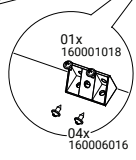
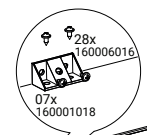
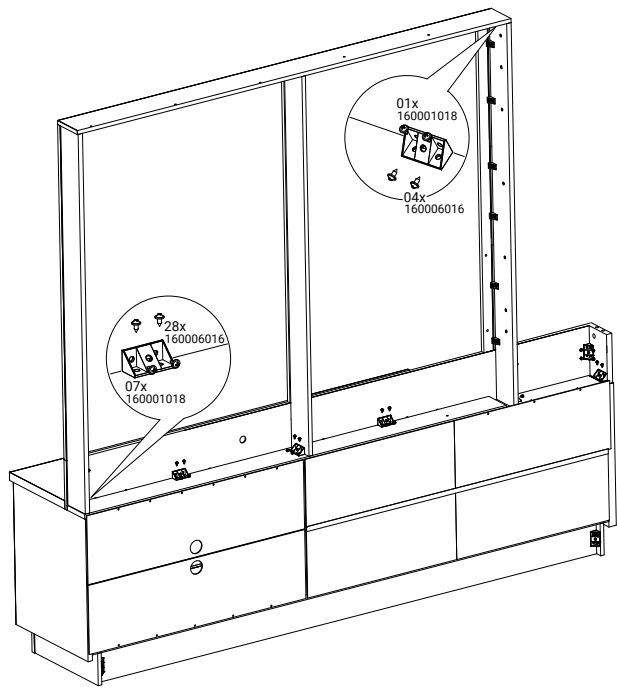
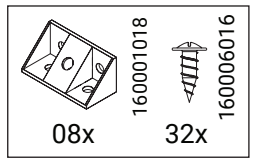

# 19

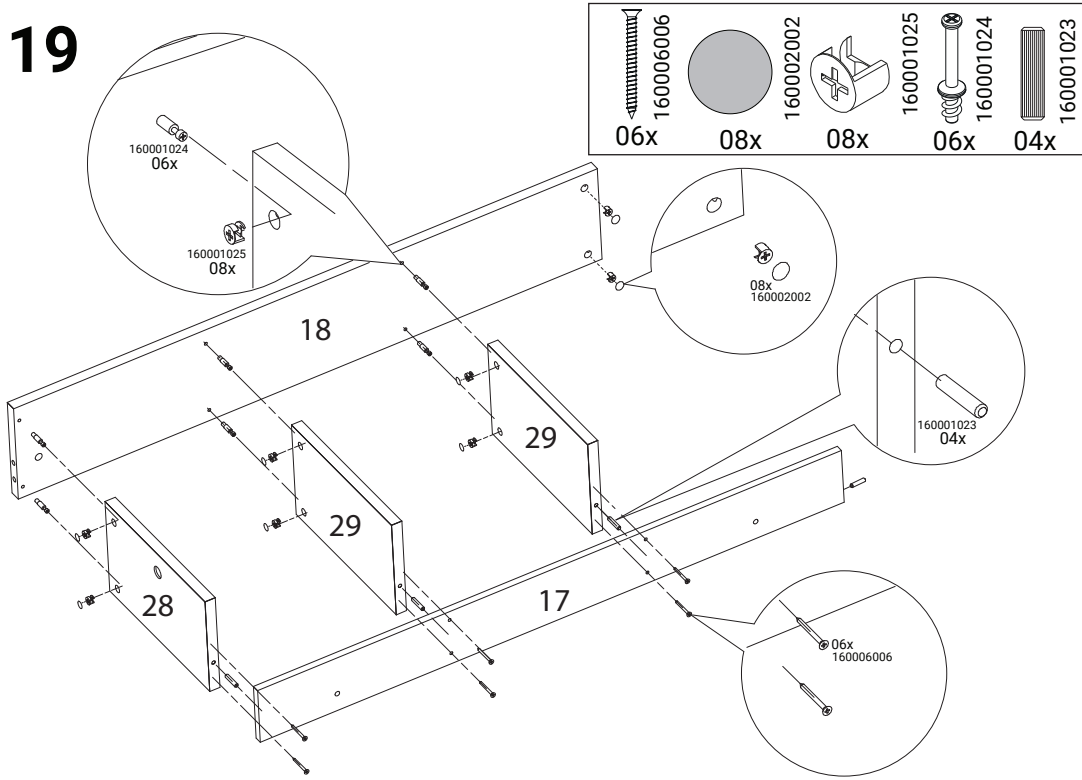

# 20

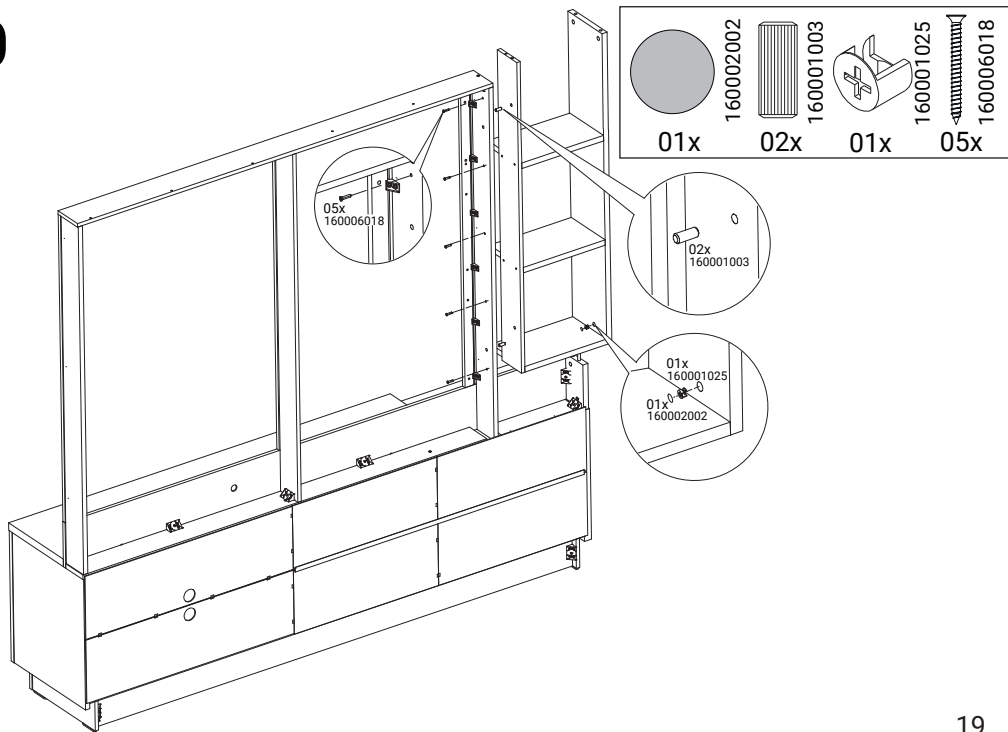

# 21

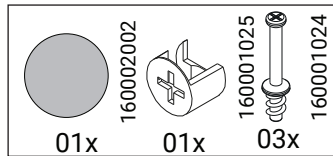
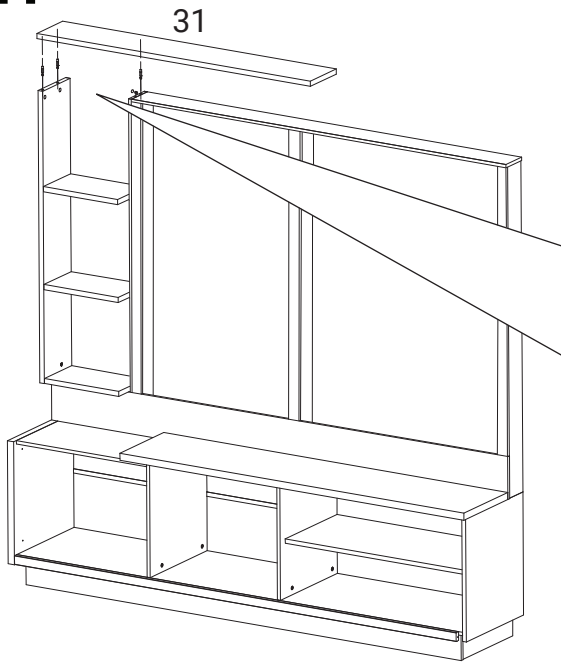

# 22

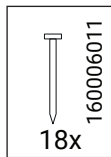
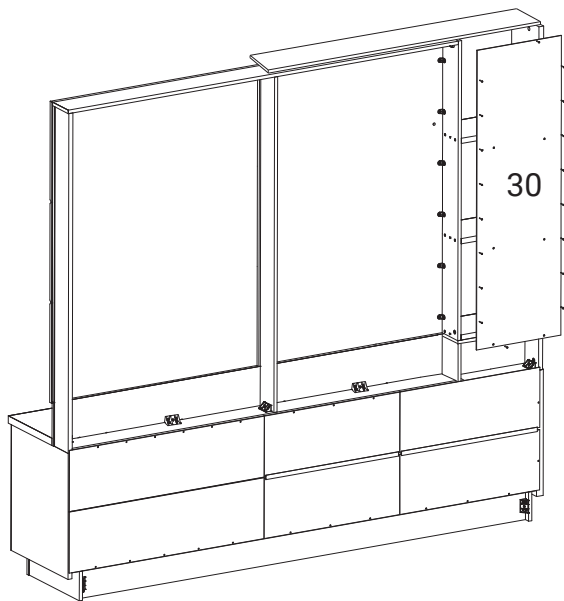

# 23

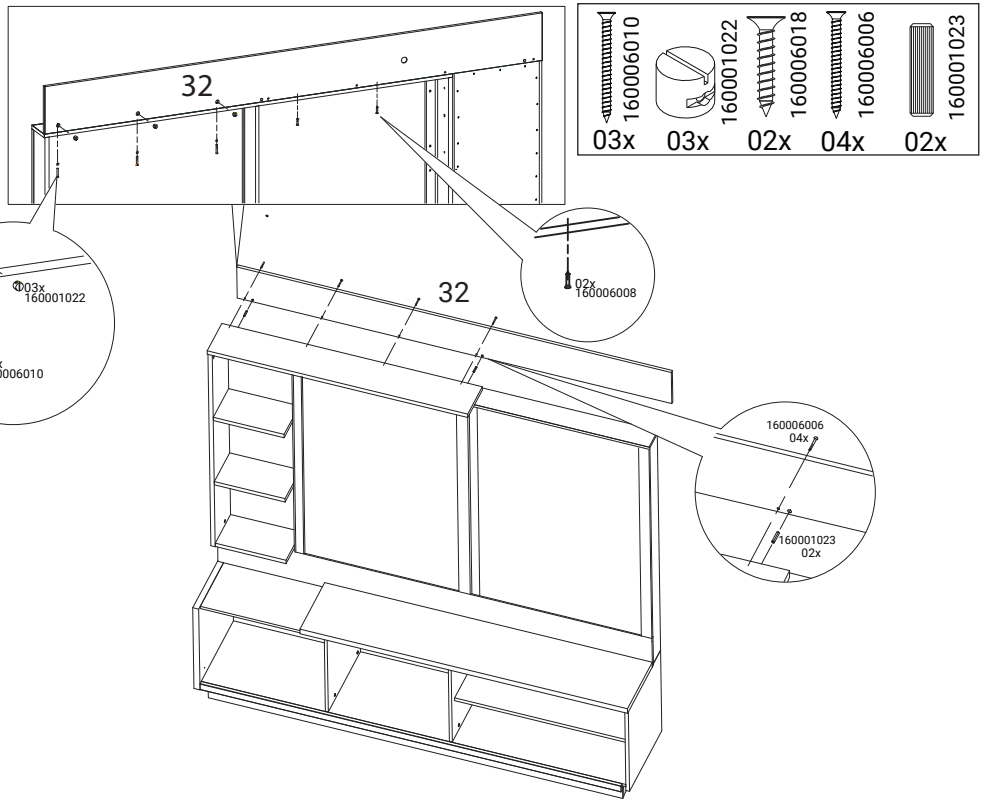

# 24

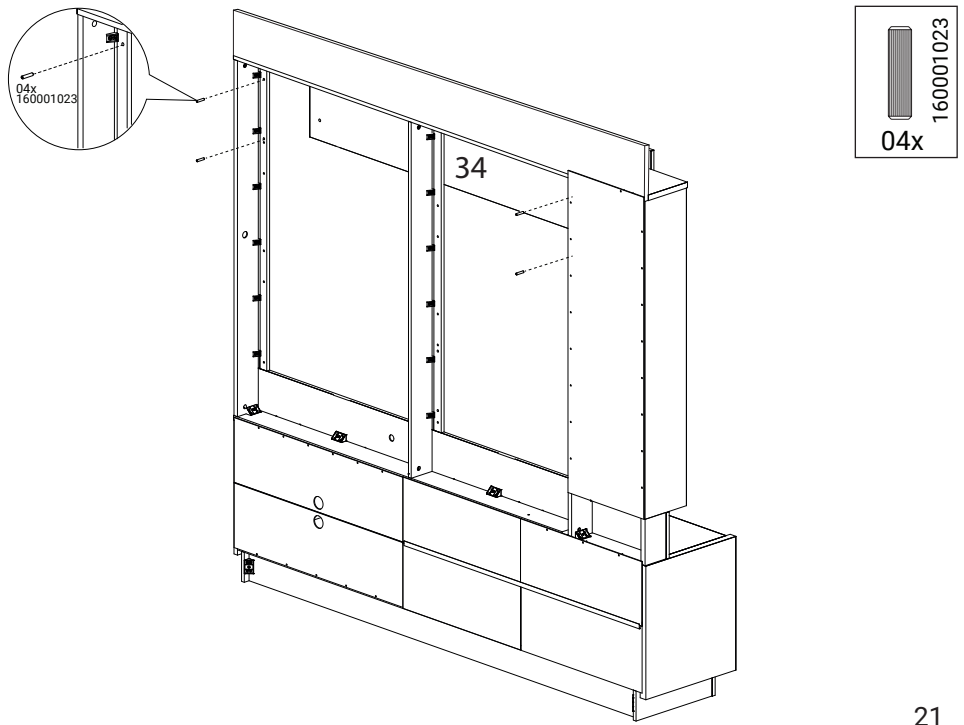

# 25

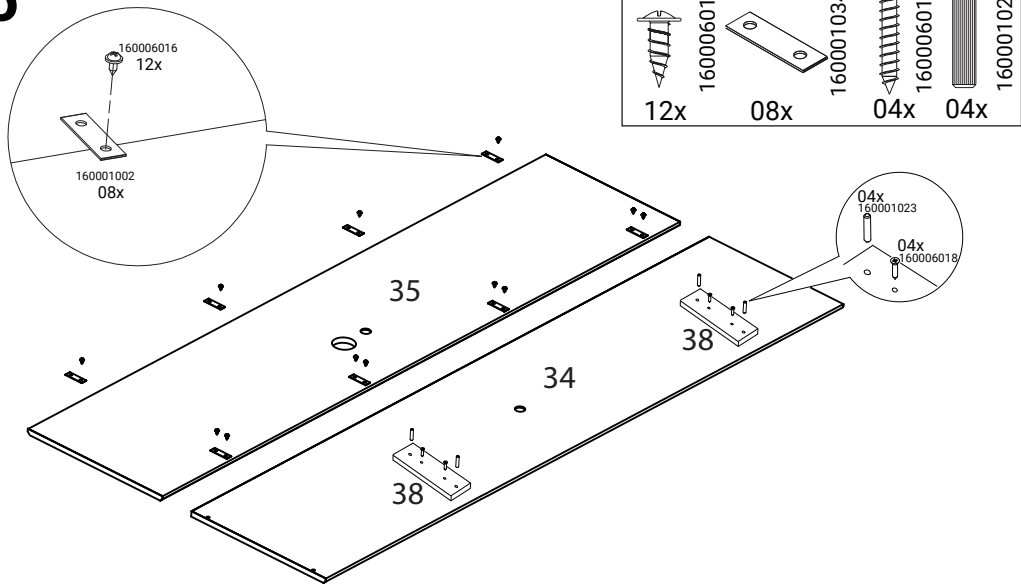

# 26

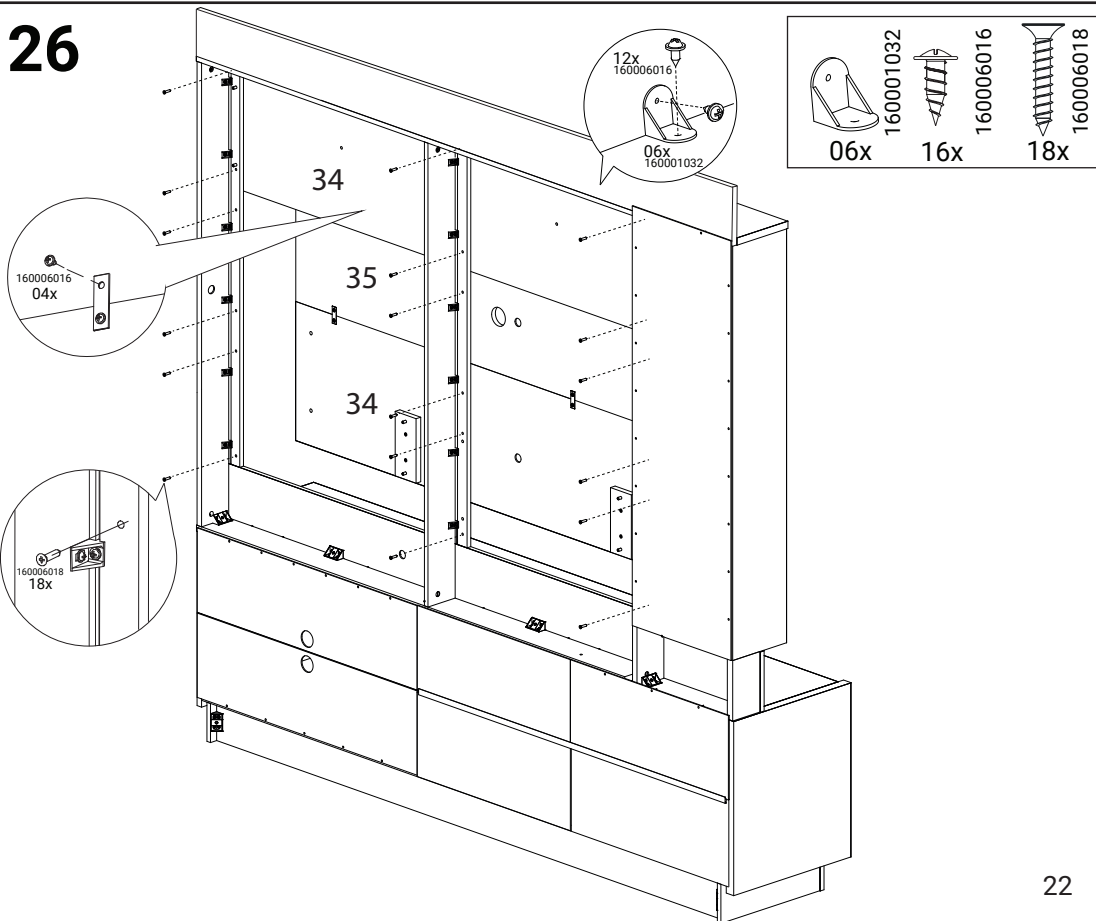

# 27

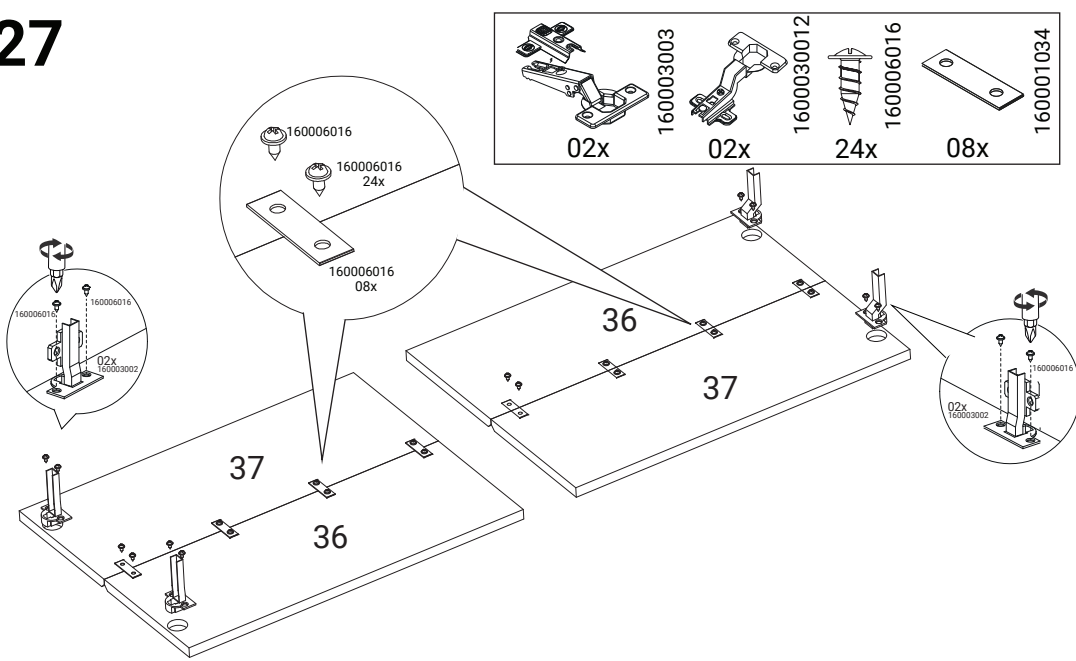

# 28

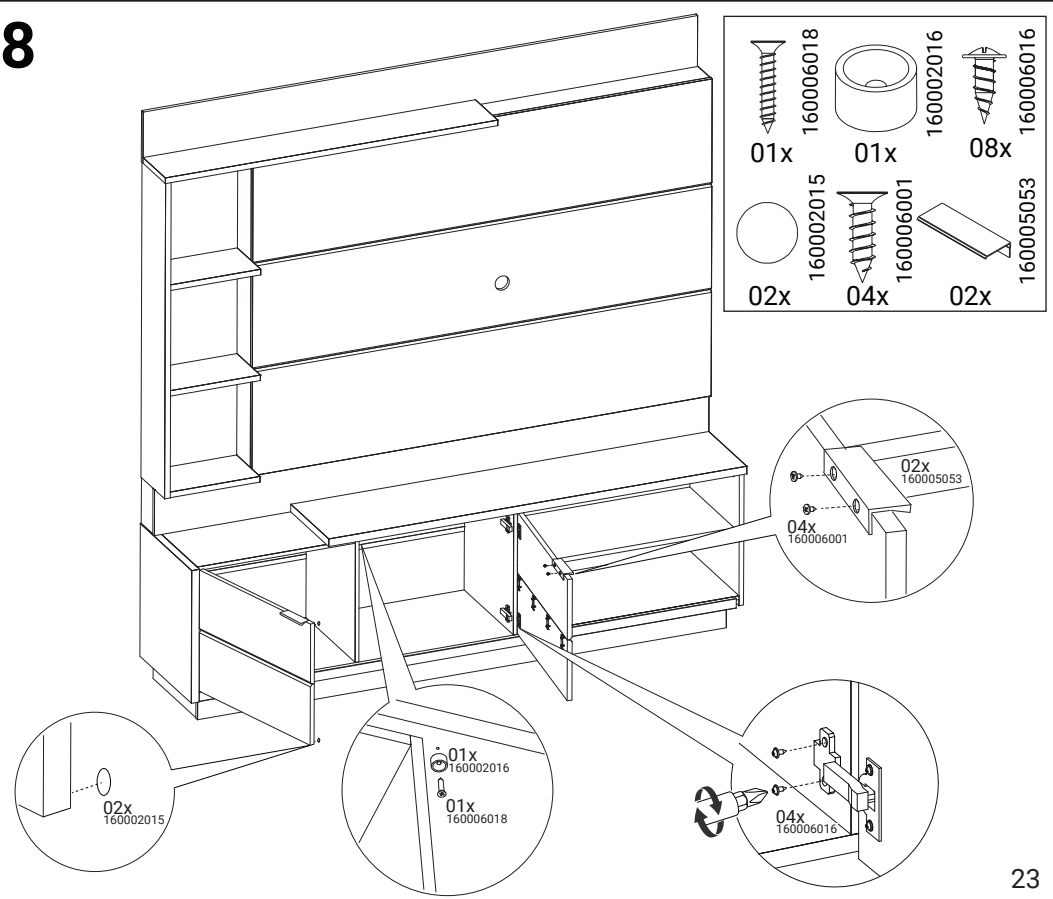

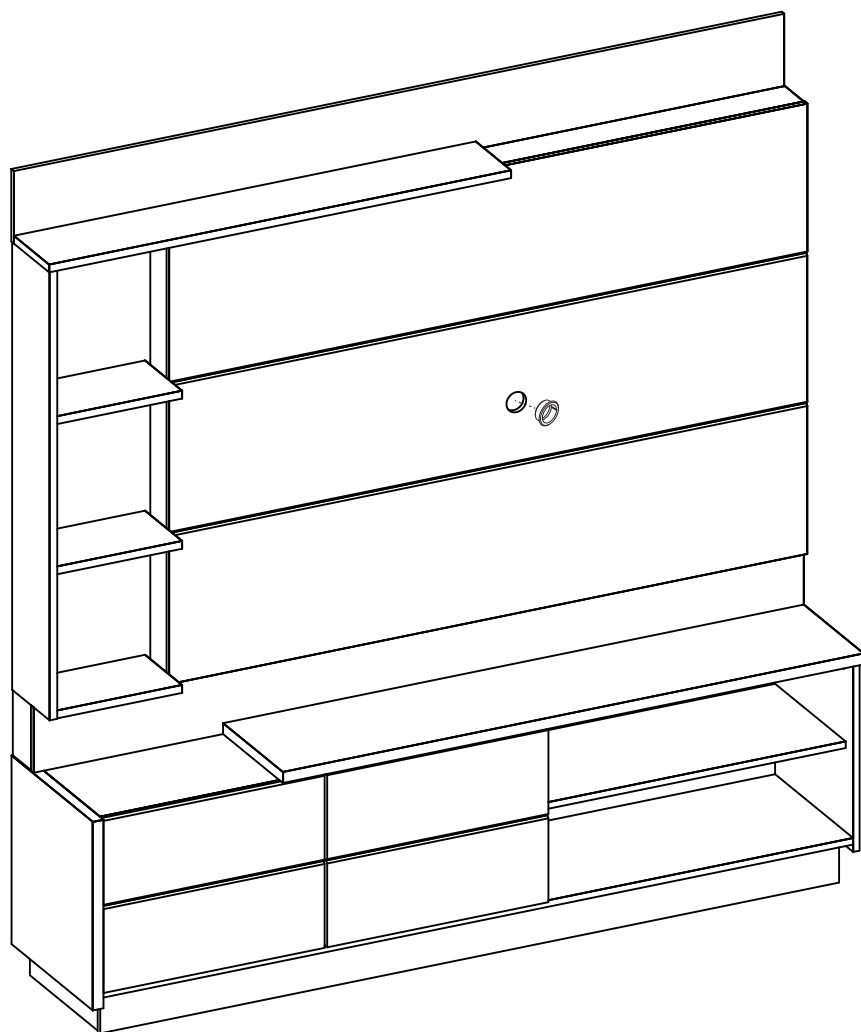
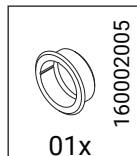



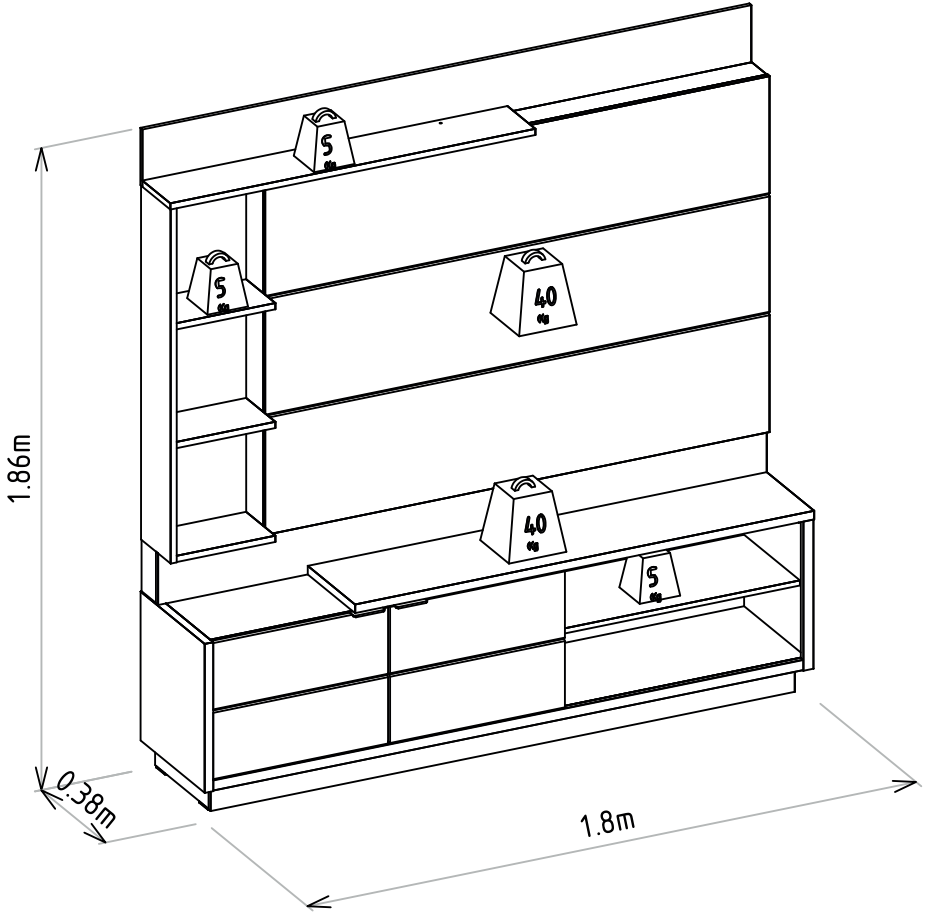

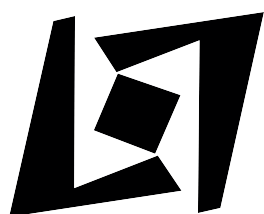

**Linea** Brasil