

Manual de montagem

Instrucciones de montaje Assembly instructions

ARMC105AMDP

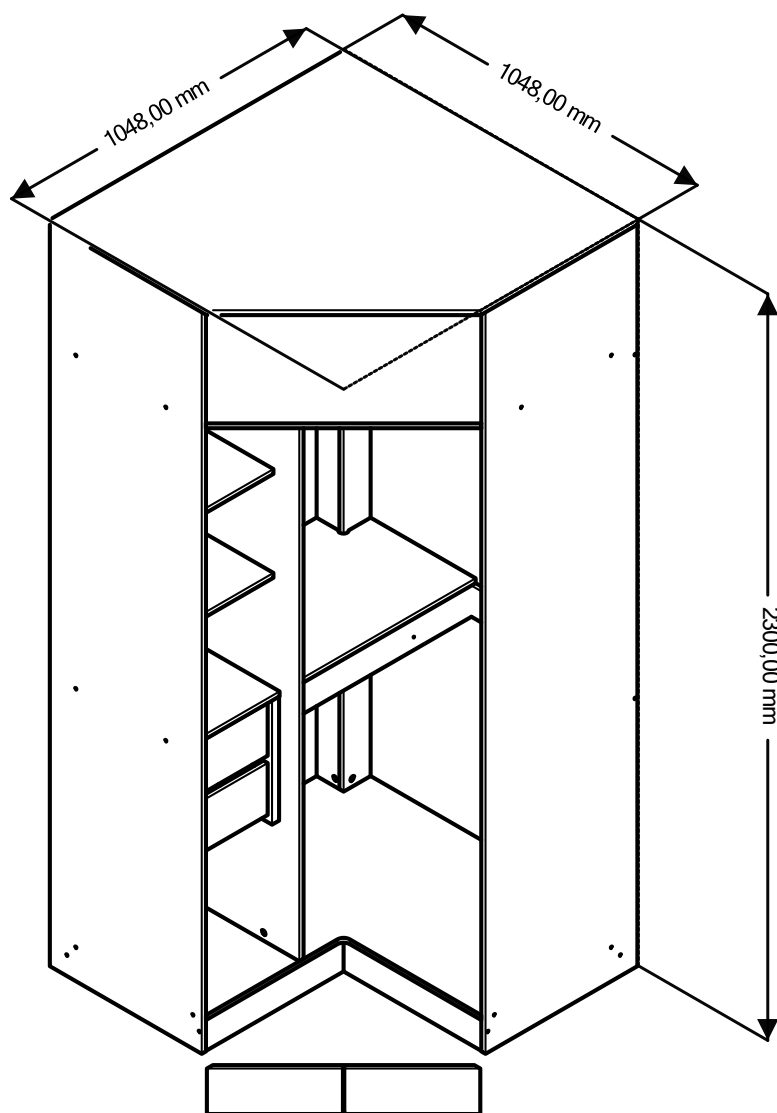

! Imagens meramente ilustrativas !
Imágenes ilustrativas/Images merely illustrative.

Dúvidas? Entre em contato:
Dudas? Ponerse em contacto:
Doubts? Get in touch:
(51) 3635-8839

A montagem deve ser efetuada por 2 pessoas.

El montaje debe ser efectuada por 2 personas.

The assembly must be done by 2 people.

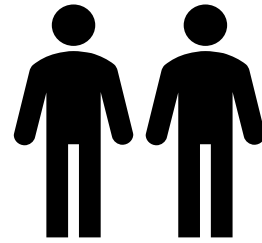

Ferramentas necessárias para montar o móvel.

Herramientas necesarias para armar el mueble.

Tools needed to assemble the furniture.



Dúvidas? Entrar em contato:

Dudas? Ponerse en contacto:

Doubts? Get in touch:

Fone: (51) 3635-8839

www.kappesberg.com.br



Montar o móvel sobre uma superfície limpa e plana.

Armar el mueble sobre una superficie limpia y plana.

Assemble the furniture on a clean, flat surface.

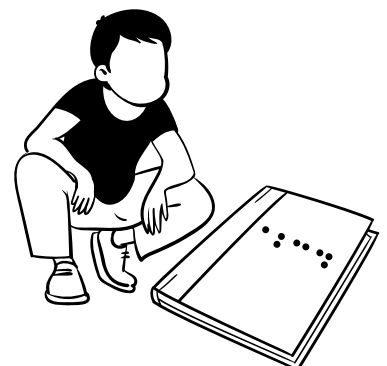

**IDENTIFICAÇÃO DAS PEÇAS / IDENTIFICACIÓN DE LAS PIEZAS PARTS
IDENTIFICATION**

Quantidade Cantidad Amount	Código Code	Descrição	Descripción	Description	C x L x E	L x W x T
2	P102213	PRATELEIRA	ESTANTE	SHELF	332 x 448 x 15 mm	13.07 x 17.64 x 0.59 in
1	P102216	TAMPO DE GAVETA	TAPA DEL CAJON	TOP OF DRAWERS	332 x 470 x 15 mm	13.07 x 18.50 x 0.59 in
1	P102410	CHAPÉU	SOMBRERO	HAT	1045 x 1045 x 15 mm	41.14 x 41.14 x 0.59 in
1	P102209	LATERAL ESQUERDA	LADO IZQUERDA	LEFT SIDE	2285 x 540 x 15 mm	89.96 x 21.26 x 0.59 in
4	P102421	COSTA	COSTA	COAST	2194 x 474 x 3 mm	86.38 x 18.66 x 0.12 in
1	P102441	LATERAL DIREITA	LADO DIRECTO	RIGHT SIDE	2285 x 540 x 15 mm	89.96 x 21.26 x 0.59 in
1	P102420	SARRAFO	LISTÓN	SLAT	2173 x 81 x 15 mm	85.55 x 3.19 x 0.59 in
1	P102418	SARRAFO	LISTÓN	SLAT	2173 x 96 x 15 mm	85.55 x 3.78 x 0.59 in
1	P102472	BASE	BASE	BASE	1030 x 1030 x 15 mm	40.55 x 40.55 x 0.59 in
1	P102435	RODAPE	ZOCALO	BASEBOARD	526 x 96 x 15 mm	20.71 x 3.78 x 0.59 in
1	P102437	DIVISORIA	DIVISION	DIVISION	1808 x 540 x 15 mm	71.18 x 21.26 x 0.59 in
4	P102202	LATERAL DE GAVETA	LADO DEL CAJÓN	DRAWER SIDE	400 x 120 x 15 mm	15.75 x 4.72 x 0.59 in
2	P102204	FUNDO DE GAVETA	FONDO DEL CAJÓN	DRAWER BOTTOM	241 x 398 x 3 mm	9.49 x 15.67 x 0.12 in
2	P102203	CABECEIRA DE GAVETA	CABEZAL DEL CAJÓN	DRAWER HEAD	228 x 120 x 15 mm	8.98 x 4.72 x 0.59 in
2	P102207	FRENTE DE GAVETA	FRENTE DEL CAJÓN	DRAWER FRONT	263 x 160 x 15 mm	10.35 x 6.30 x 0.59 in
4	P102206	AFASTADOR	RETRACTOR	SEPARADOR	384 x 70 x 25 mm	15.12 x 2.76 x 0.98 in
1	P102471	TAMPO DE GAVETA / USINADA	TAPA DEL CAJON	TOP OF DRAWERS	682 x 470 x 15 mm	26.85 x 18.50 x 0.59 in
1	P102433	BASE DO MALEIRO / USINADA	BASE	BASE	1030 x 1030 x 15 mm	40.55 x 40.55 x 0.59 in
1	P102438	SARRAFO	LISTÓN	SLAT	587 x 96 x 15 mm	23.11 x 3.78 x 0.59 in
1	P102428	RODAPE	ZOCALO	BASEBOARD	997 x 96 x 15 mm	39.25 x 3.78 x 0.59 in
1	P102436	RODAPE	ZOCALO	BASEBOARD	491 x 96 x 15 mm	19.33 x 3.78 x 0.59 in
1	P102434	RODAPE	ZOCALO	BASEBOARD	962 x 96 x 15 mm	37.87 x 3.78 x 0.59 in
2	P102439	SARRAFO	LISTÓN	SLAT	934 x 96 x 15 mm	36.77 x 3.78 x 0.59 in
1	P102440	SARRAFO	LISTÓN	SLAT	668 x 96 x 15 mm	26.30 x 3.78 x 0.59 in
2	P102470	RODAPE	ZOCALO	BASEBOARD	342 x 140 x 15 mm	13.46 x 5.51 x 0.59 in

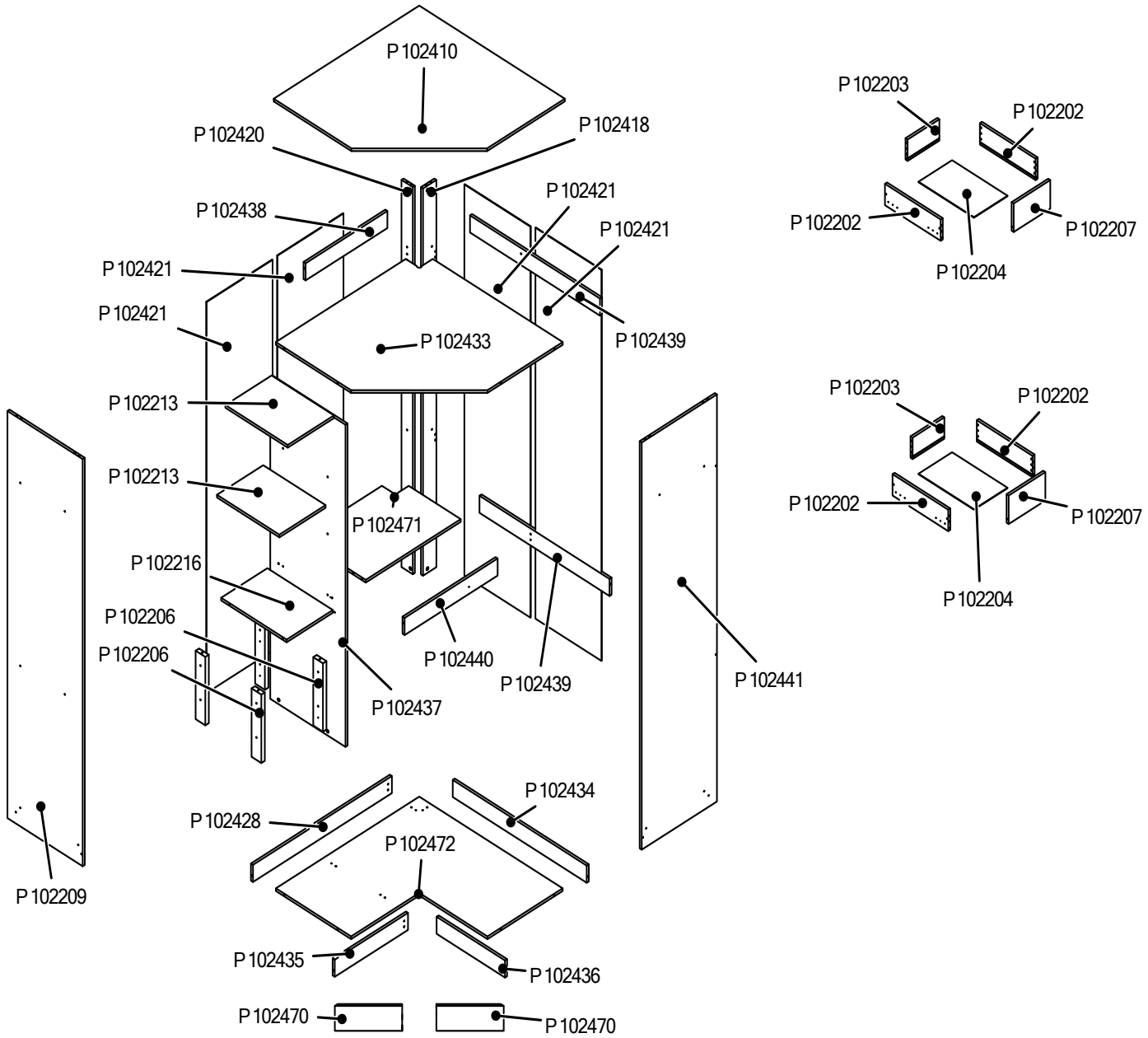











IDENTIFICAÇÃO DOS ACESSÓRIOS / IDENTIFICACIÓN DE ACCESORIOS IDENTIFICATION OF ACCESSORIES

NOTAS: A separação dos acessórios antes de iniciar a montagem facilitará a mesma. Em caso de dúvida na identificação, coloque o acessório sobre a régua.

Nota: Separar los accesorios antes de iniciar el montaje facilitará el mismo. En caso de duda en la identificación, coloque el accesorio en la regla.

NOTE: Separating the accessories before starting assembly will make it easier. In case of doubt in the identification, place the accessory on the ruler.

	Quantidade / Cantidad / Amount	Código / Code	Descrição	Descripción	Description
	2	PX	PUX. REVESTIDO DOURADO FX120 522MM (224MM EF)	MANILLA DE PUERTA 522MM	PULLER 522MM
	17	054117	P.CHATO 3,5 X 25 CAB. PHILLIPS ZB/BC (IDELLI)	TORNILLO 3,5 X 25	SCREW 3,5 X 25
	56	001802	CAVILHAS DE MADEIRA 6X30 PINUS	TARUGO 6X30MM	DOWEL 6X30MM
	14	030950	TAMBOR P/ MINIFIX 15MM ZAMAQ 09.11.007	CILINDRO 15MM	BARREL 15MM
	14	030945	PARAFUSO DE ACO P/ MINIFIX	TORNILLO DE ACERO PARA MINIFIX	STEEL SCREW FOR MINIFIX
	34	000226	P.CHATO 4,0 X 40MM	TORNILLO 4,0 X 40MM	SCREW 4,0 X 40MM
	8	000118	SUP. P/ PRAT. 6 X 8MM BEGE (COR 004)	SOPORTE DE ESTANTE 6 X 8	SHELF SUPPORT 6 X 8
	2	001925	CAVILHA 6 X 50MM MADEIRA	TARUGO 6 X 50MM	DOWEL 6 X 50MM
	168	000107	PREGO 10 X 10 (0,308G) LISO	CLAVO 10 X 10	NAIL 10 X 10
	69	004214	P.CHATO 3,5 X 14 CAB. PHILLIPS REBAIXADA ZB	TORNILLO 3,5 X 14MM	SCREW 3,5 X 14MM
	9	000899	CANTONEIRA PLASTICA PRETA	CANTONERA	PLASTIC HANDLE

IDENTIFICAÇÃO DOS ACESSÓRIOS / IDENTIFICACIÓN DE ACCESORIOS IDENTIFICATION OF ACCESSORIES

	1	076864	ROLICO OBLONGO 15X25MM ALUMINIO NATURAL FRISADO 976MM	ROLICO OBLONGO 15X25MM ALUMINIO NATURAL FRISADO 976MM	ROLICO OBLONGO 15X25MM ALUMINIO NATURAL FRISADO 976MM
	1	076865	ROLICO OBLONGO 15X25MM ALUMINIO NATURAL FRISADO 553MM	ROLICO OBLONGO 15X25MM ALUMINIO NATURAL FRISADO 553MM	ROLICO OBLONGO 15X25MM ALUMINIO NATURAL FRISADO 553MM
	17	13MM	TAPA FURO 13MM	TAPA DEL AGUJERO 13MM	SCREW CAP COVER 13MM
	12	19MM	TAPA FURO 19MM	TAPA DEL AGUJERO 19MM	SCREW CAP COVER 19MM
	24	061971	P.PANELA 4,0 X 14 ZB P/DOBRADICA	TORNILLO 4,0 X 14	SCREW 4,0 X 14
	6	015021	DOBRAD. 35MM 45°	BISAGRA 35MM 45°	HINGE 35MM 45°
	8	001901	SAPATA DESLIZADORA PRETA 15 X 6 (02.02.026)	ZAPATO 15 X 6	SHOE 15 X 6
	8	000108	PREGO 12 X 12 (0,6127G) ARDOX	CLAVO 12 X 12	NAIL 12 X 12
	4	041921	SUP. P/ CABIDEIRO OBLONGO METAL COR ALU. ESCURO	SOPORTE PERCHA	CLOTHES RACK
	2	038305	CORREDICA TELESCOPICO MINI LIGHT (H32/30) 400MM	CORREDICA TELESCOPICO MINI LIGHT (H32/30) 400MM	CORREDICA TELESCOPICO MINI LIGHT (H32/30) 400MM
	8	000414	P.PANELA 4,0 X 35 CAB. PHILLIPS ZB/BC	TORNILLO 4,0 X 35	SCREW 4,0 X 35
	4	018458	SUPORTE TRIANGULAR PRETO	SOPORTE TRIANGULO NEGRO	BLACK TRIANGLE SUPPORT
	4	005256	PARAFUSO CHATO 4,0 X 20 BC	TORNILLO PLANO 4,0 X 20 BC	FLAT SCREW 4,0 X 20 BC
	2	075246	PERF. H26 2190MM	PERFIL H 2190MM	PROFILE H 2190MM

INSTALAÇÃO MINIFIX

Identificar seta no corpo do tambor de minifix. A seta DEVE apontar para o buraco na borda do painel. Empurrar o tambor até o buraco.

INSTALACIÓN DE LA LEVA

Identifique la flecha en los muertos de la leva. La flecha debe apuntar hacia el agujero en el borde del panel. Empuje la leva hasta el fondo del orificio.

INSTALLING CAM

Identify arrow on head of cam. Arrow MUST point toward hole in edge of panel. Push cam all the way down into hole.

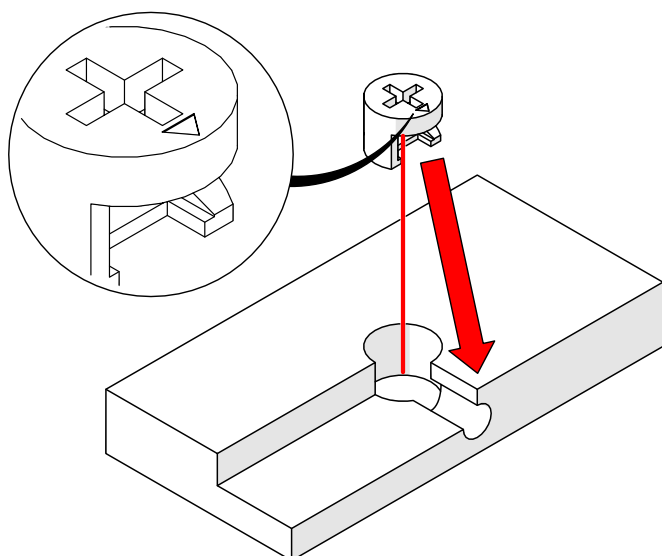

ALINHAMENTO DO TAMBOR E PARAFUSO

A seta do tambor de minifix deve ser aponta para o buraco e inserir o parafuso do minifix do tambor contido no buraco. Certifique-se de que as peças se unam.

ALINEACIÓN DE LA LEVA Y EL PASADOR

Asegúrese de que la flecha de la leva apunte hacia el orificio e inserte la clavija de la leva en el orificio. Asegúrese de que las piezas se unen.

CAM AND DOWEL ALIGNMENT

Ensure the arrow on the cam points toward hole and insert cam dowel into hole. Make sure pieces join together.

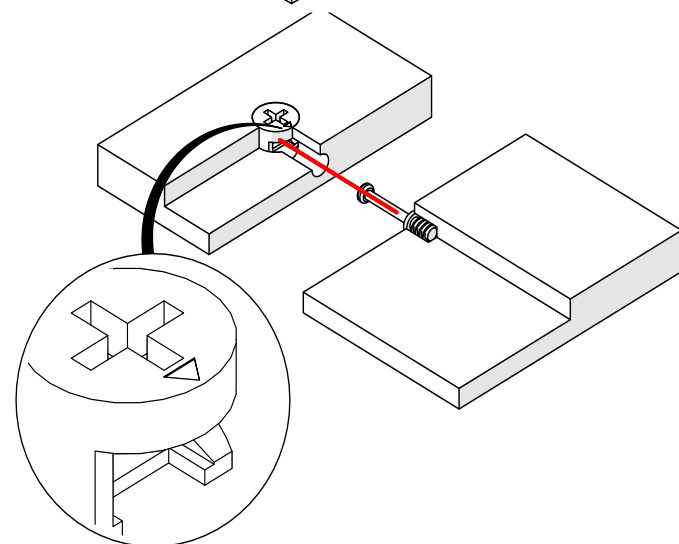

CÂMARA DE COMPENSAÇÃO DE TENSÃO

Use uma chave de fenda para girar a came. Girar o tambor minifix (no sentido horário) até que esteja totalmente apertado. Ligeiramente mais de meia volta.

APRIETE DE LA LEVA

Utilice un destornillador para girar la leva. Gire la leva (en el sentido de las agujas del reloj) hasta que esté completamente apretada. Un poco más de media vuelta.

TIGHTENING CAM

Use screwdriver to turn cam. Turn cam (clockwise) until fully tightened. Slightly more than half a turn.

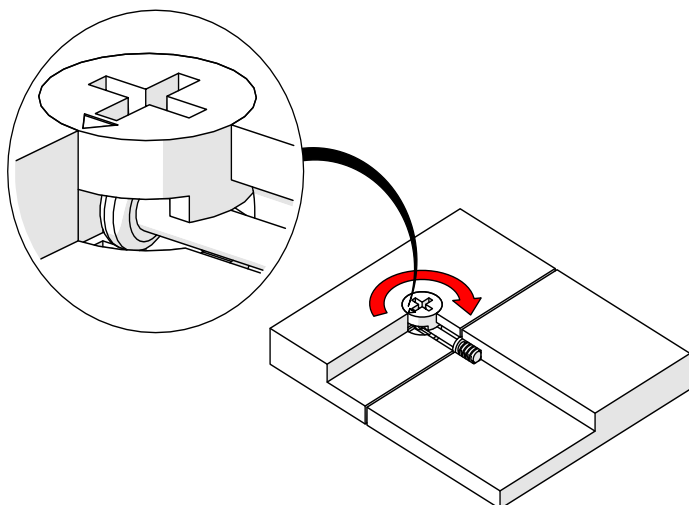

PASSO / PASO / STEP 1

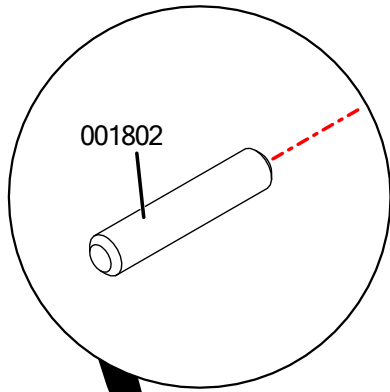

Cod.	Qtde.
001802	8

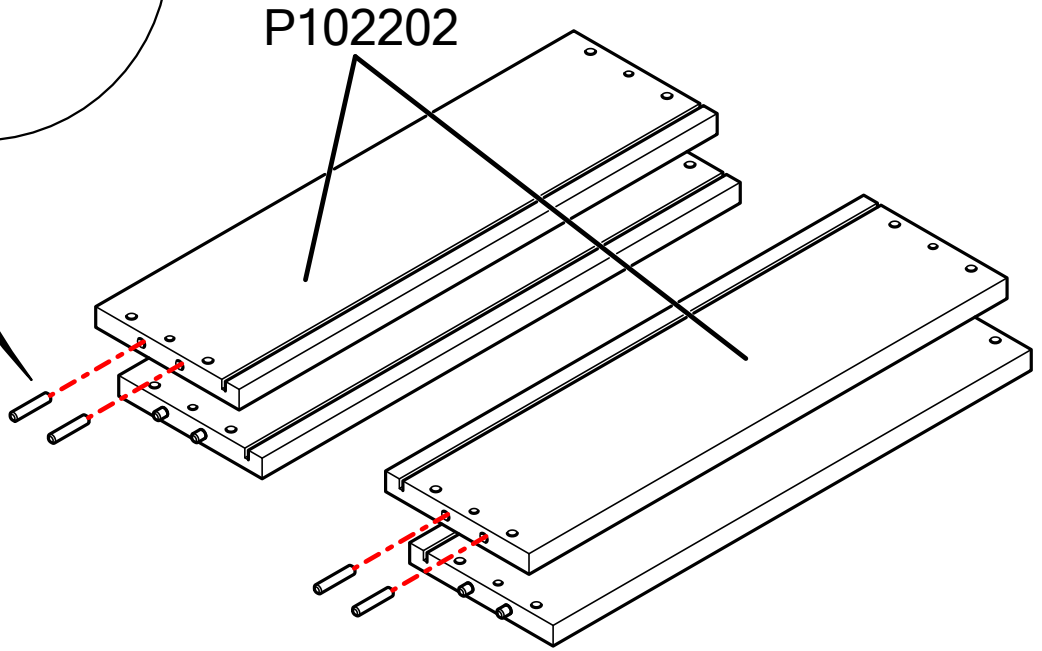

Cod.	Qtde.
001802	8

PASSO / PASO / STEP 2

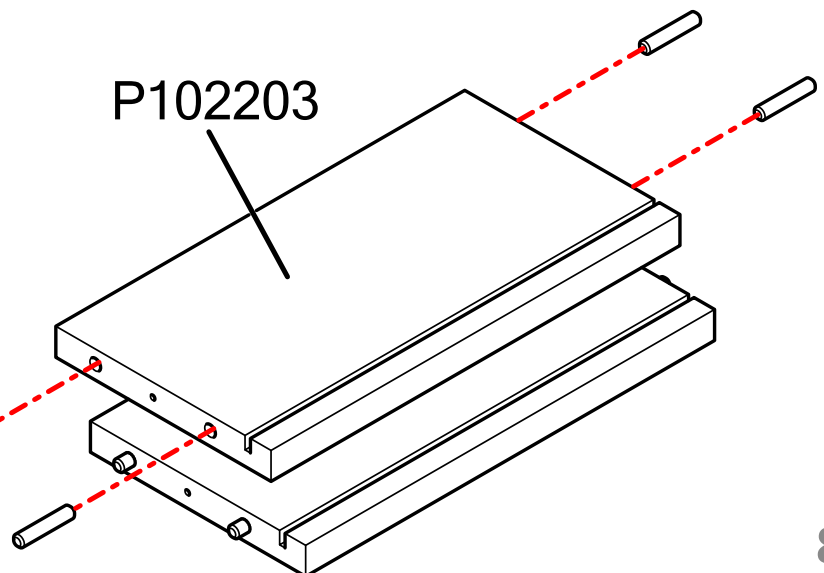
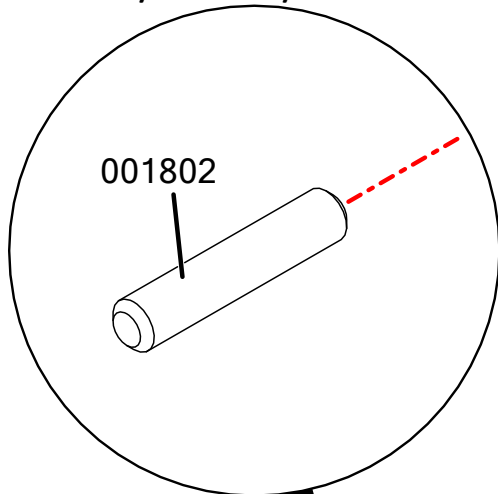

PASSO / PASO / STEP 3

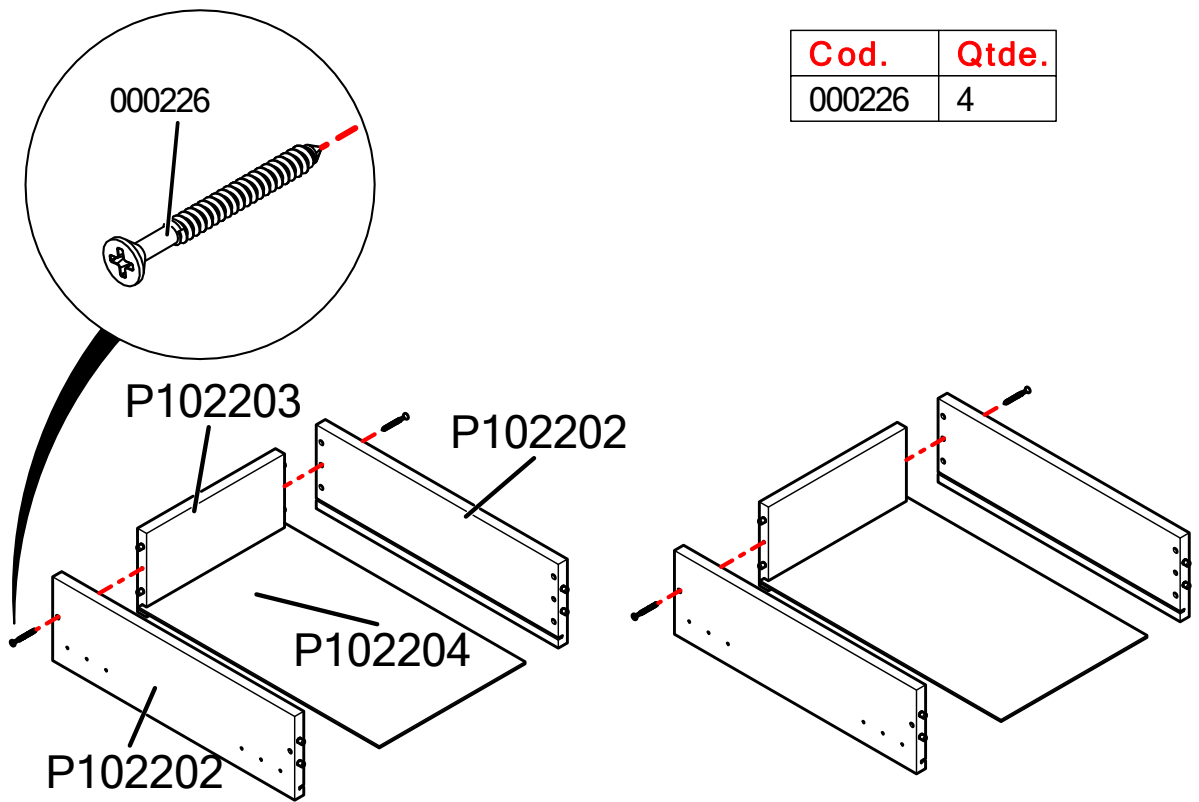

Cod.	Qtde.
000226	4

PASSO / PASO / STEP 4

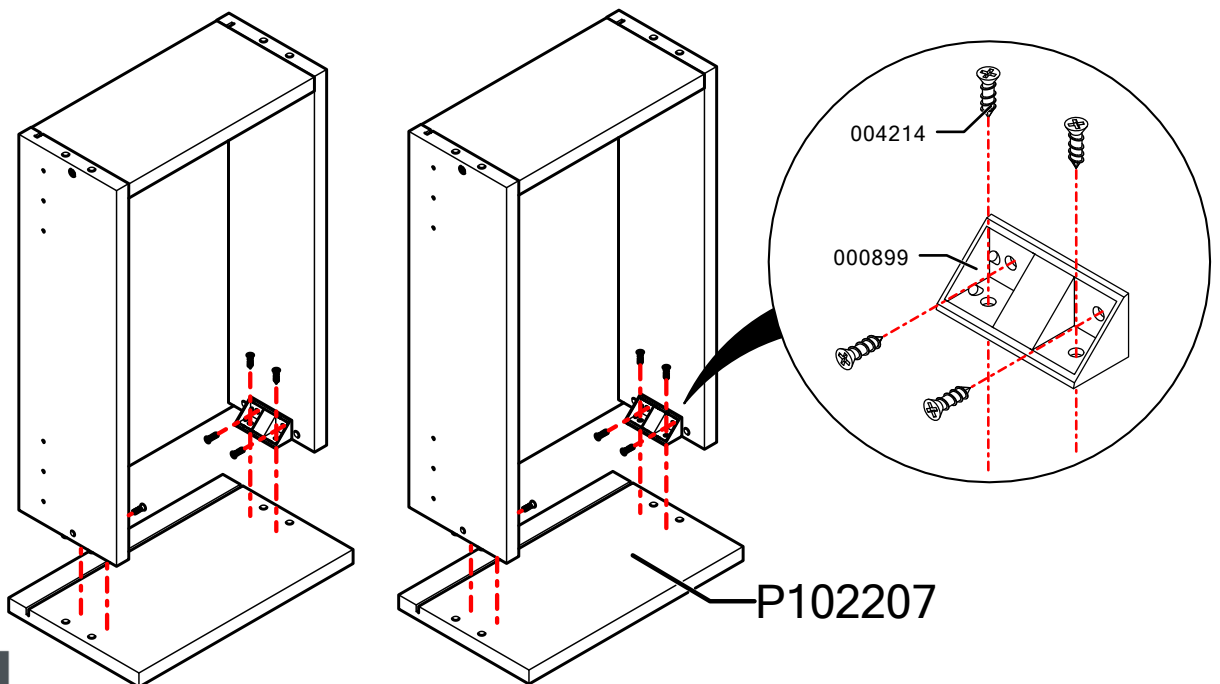

Cod.	Qtde.
000899	4
004214	16

PASSO / PASO / STEP 5

Cod.	Qtde.
005256	4
018458	4

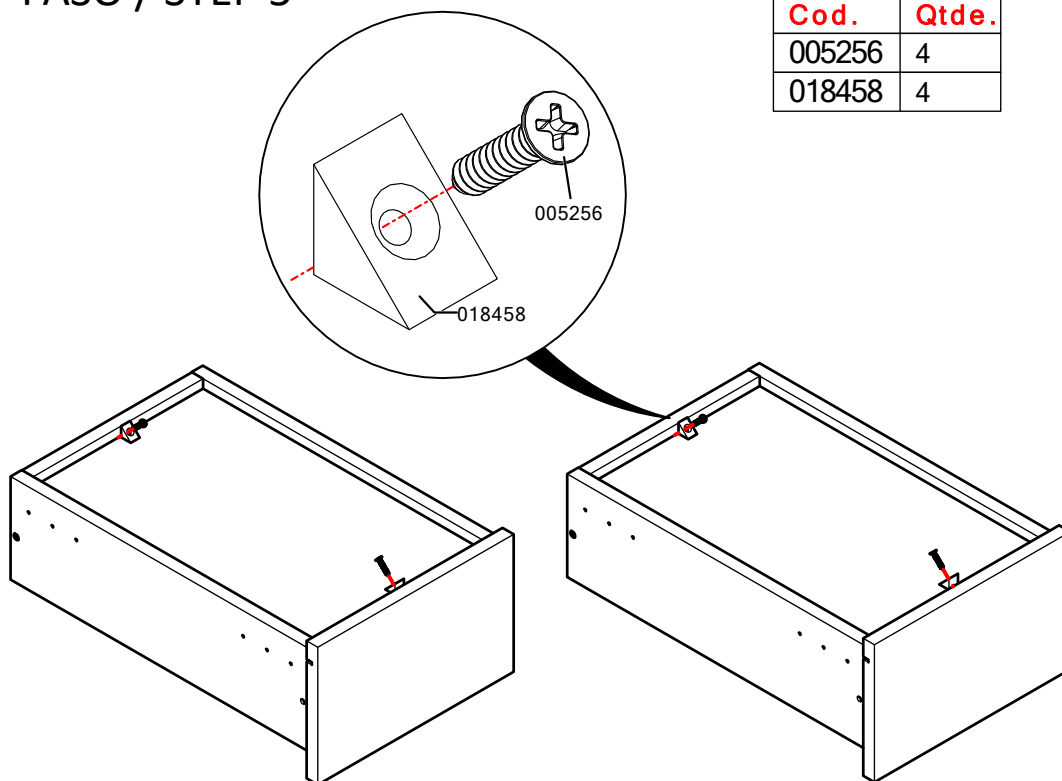

PASSO / PASO / STEP 6

Cod.	Qtde.
004214	12
038305	2

Atrás / Espalda / Back

Central / Centro / Center

Frente / Delantera / Front

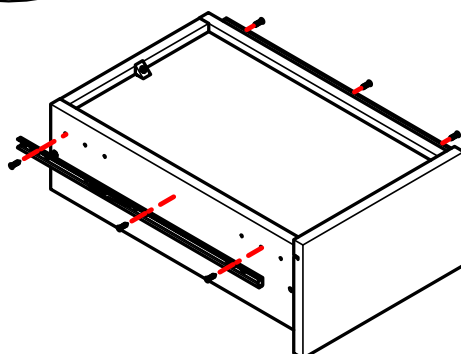
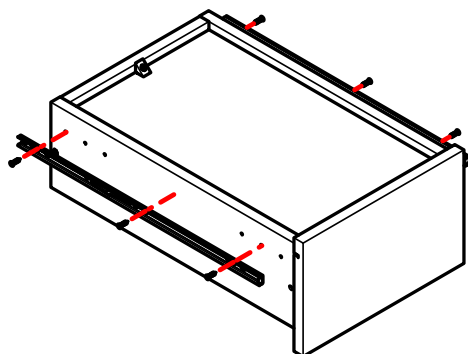
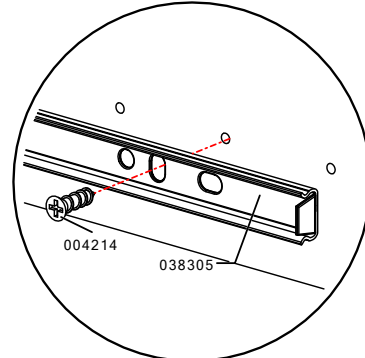
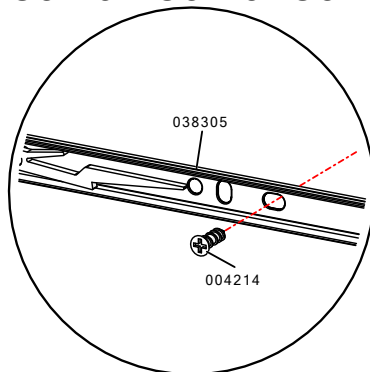
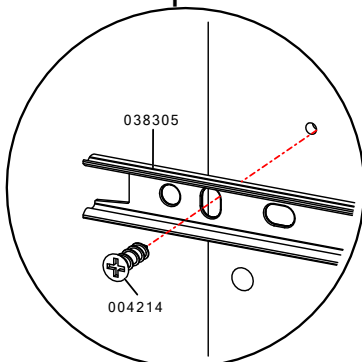

PASSO / PASO / STEP 7

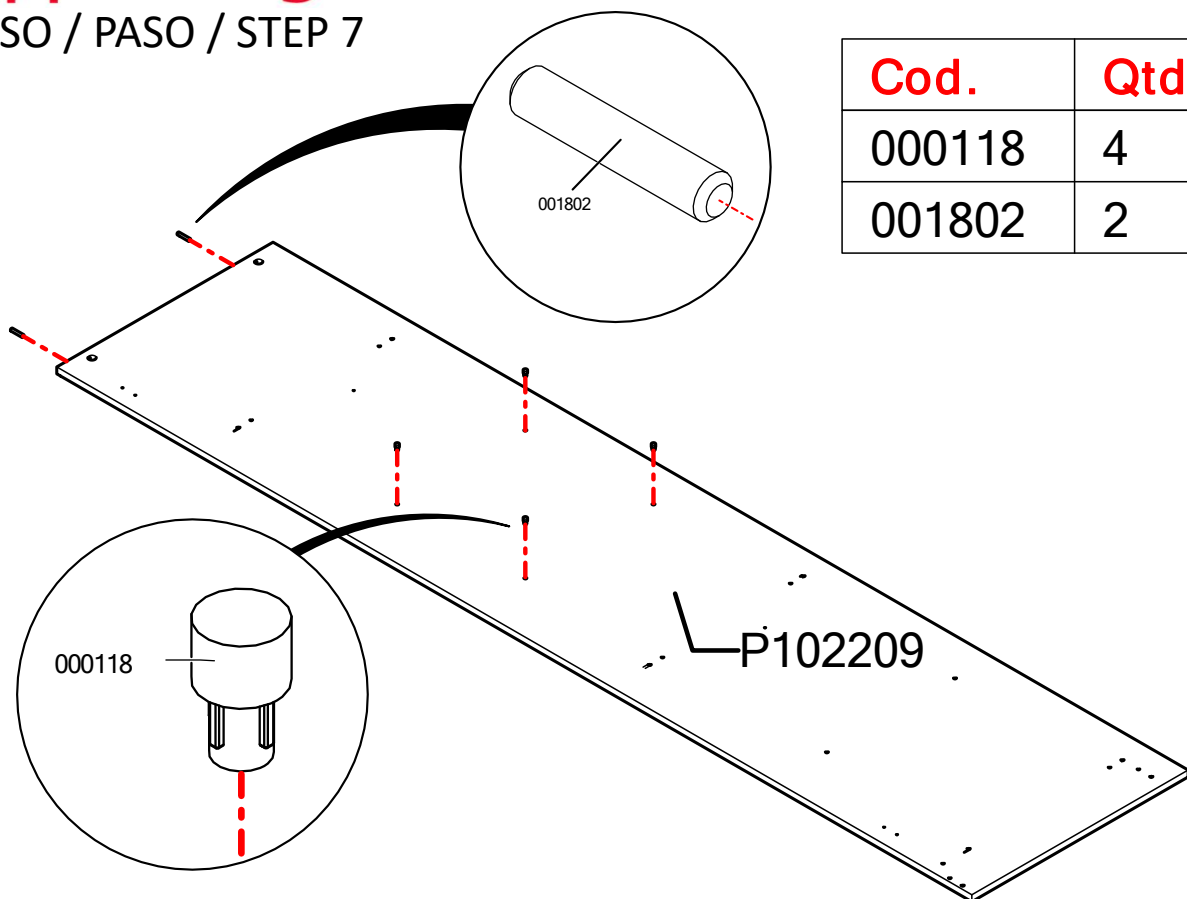

Cod.	Qtde.
000118	4
001802	2

PASSO / PASO / STEP 8

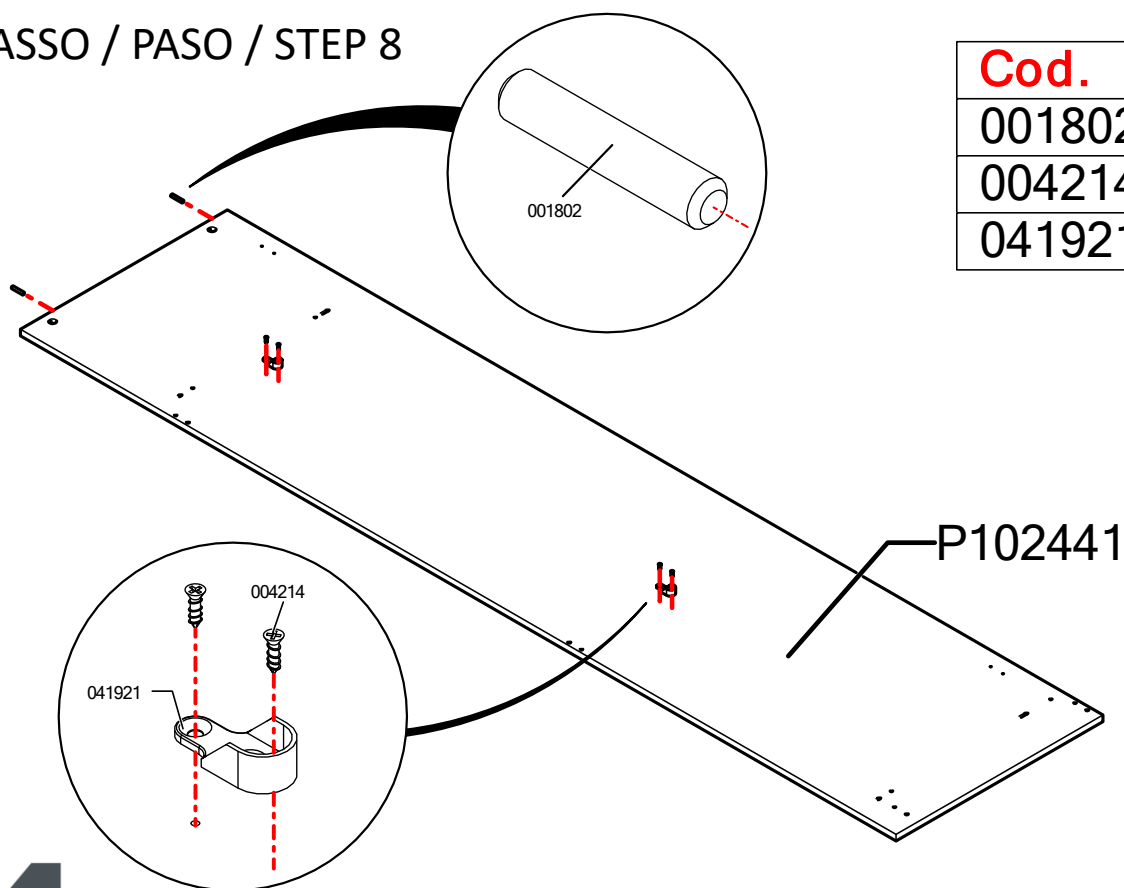

Cod.	Qtde.
001802	2
004214	4
041921	2

PASSO / PASO / STEP 9

Cod.	Qtde.
030945	6

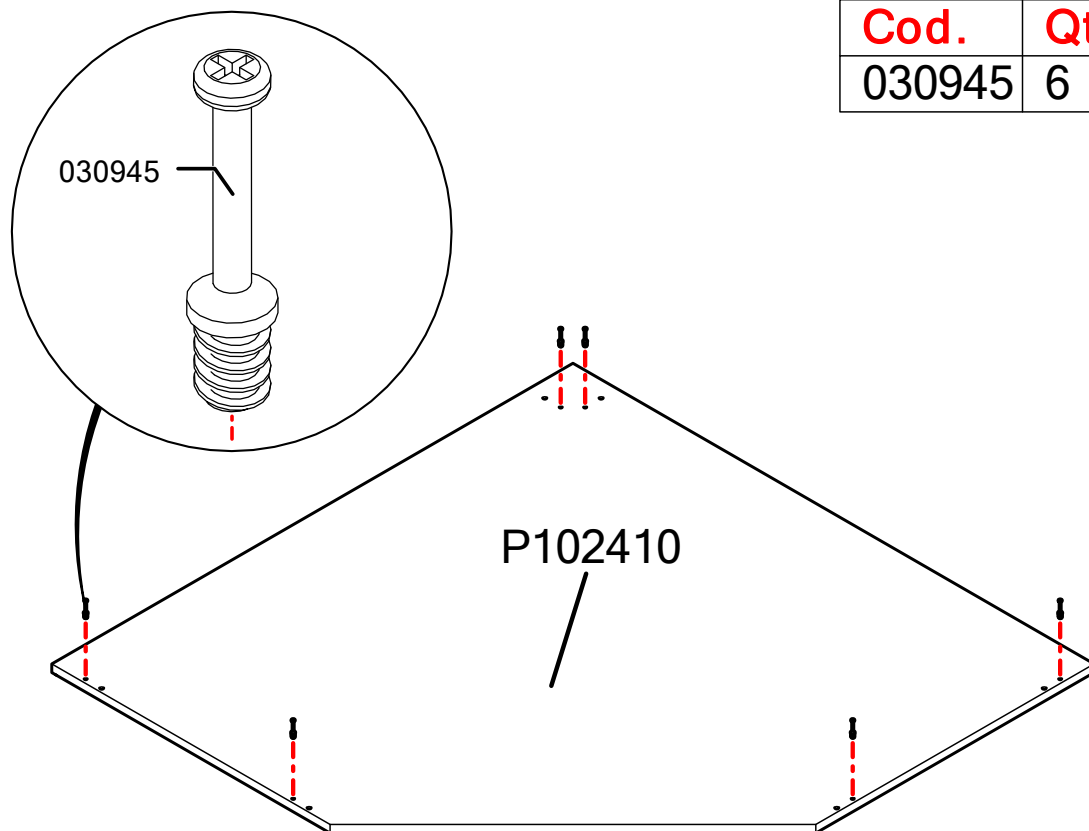

PASSO / PASO / STEP 10

Cod.	Qtde.
001802	2
001925	2

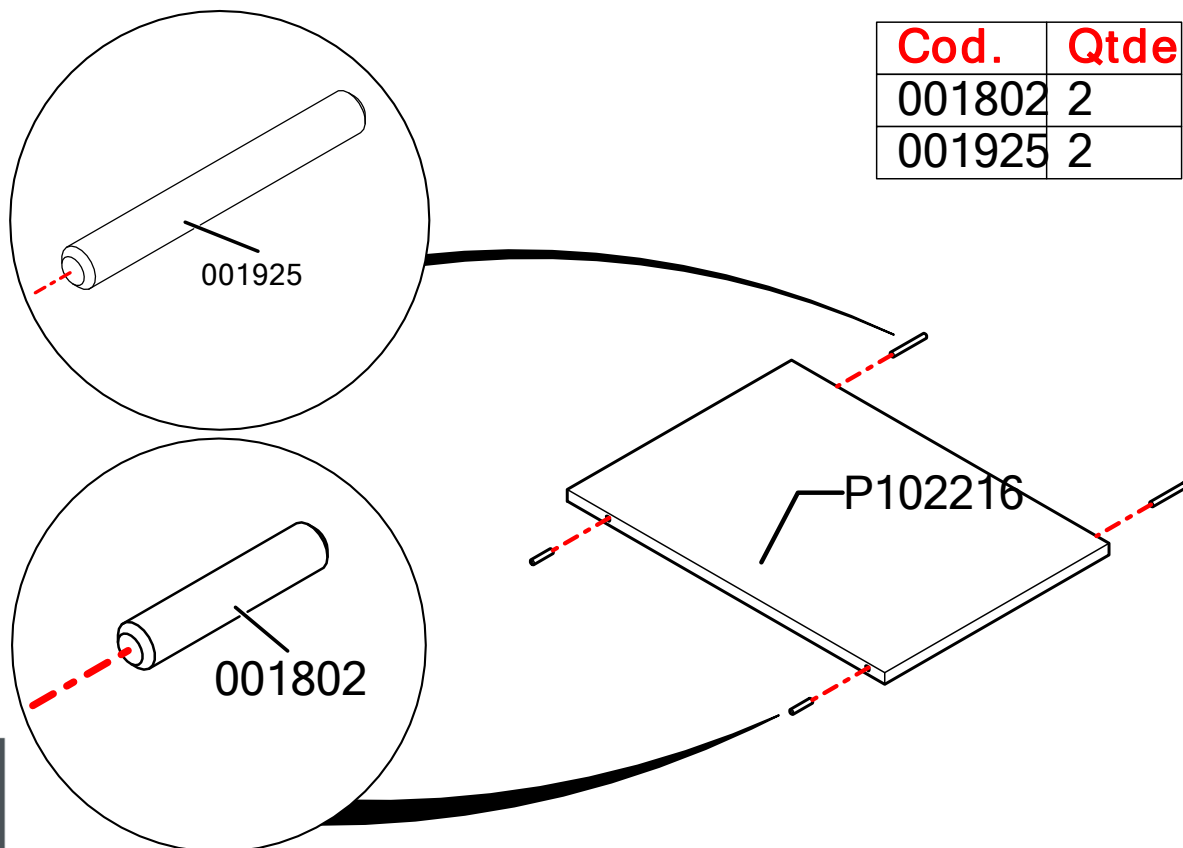

PASSO / PASO / STEP 11

Cod.	Qtde.
001802	2

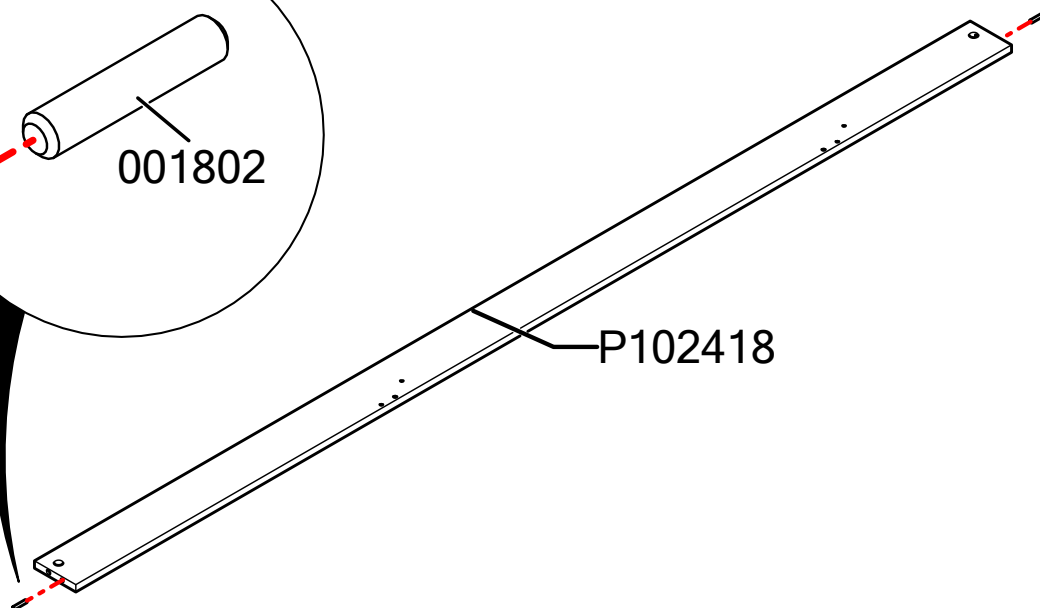
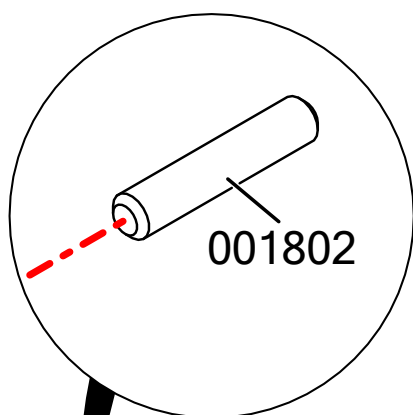

PASSO / PASO / STEP 12

Cod.	Qtde.
001802	2

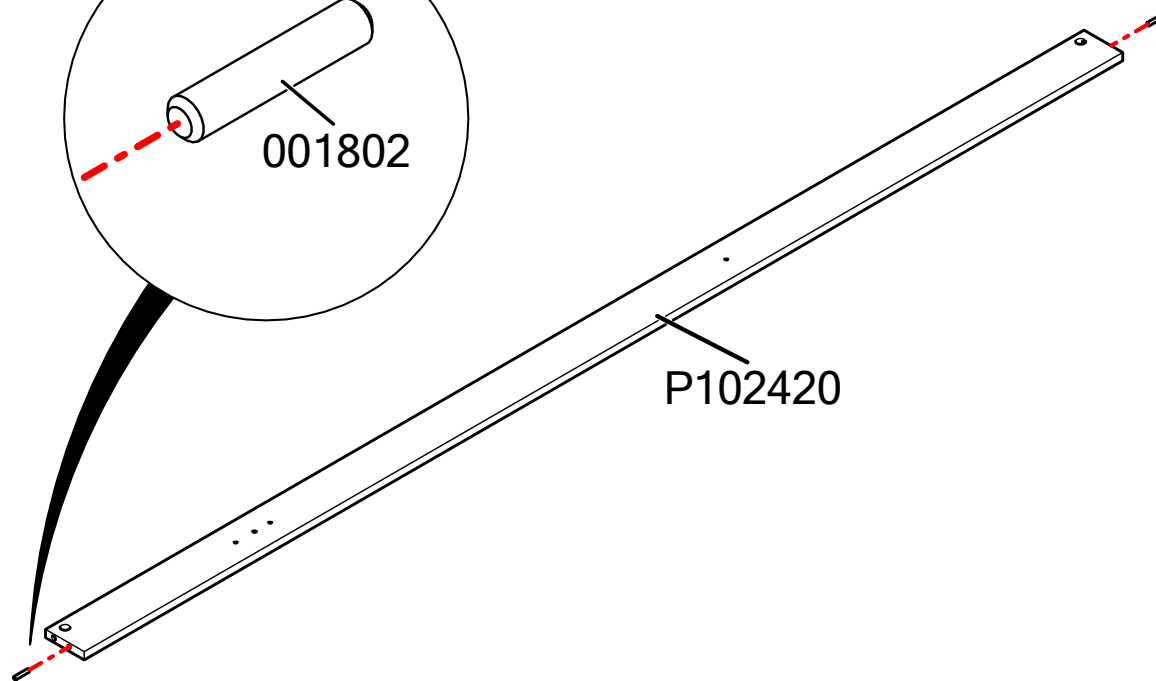
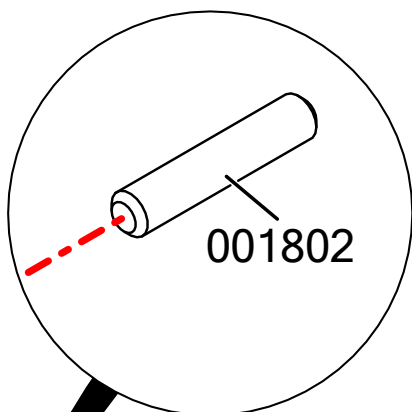

PASSO / PASO / STEP 13

Cod.	Qtde.
001802	2

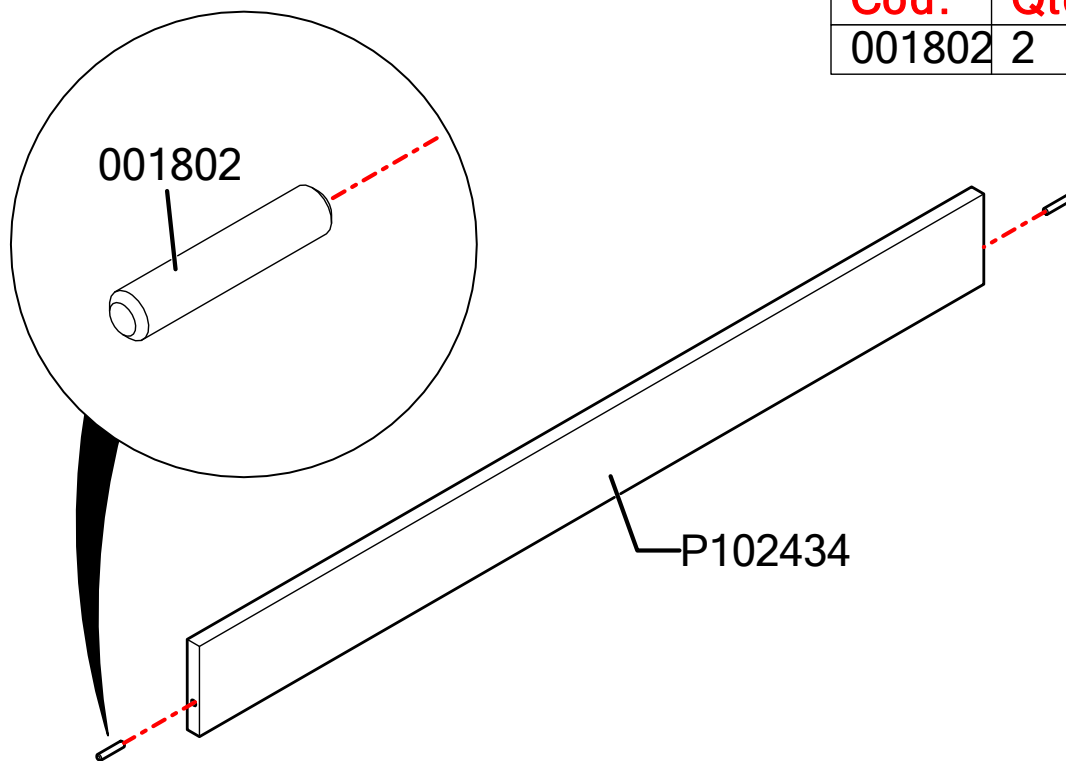

PASSO / PASO / STEP 14

Cod.	Qtde.
001802	1

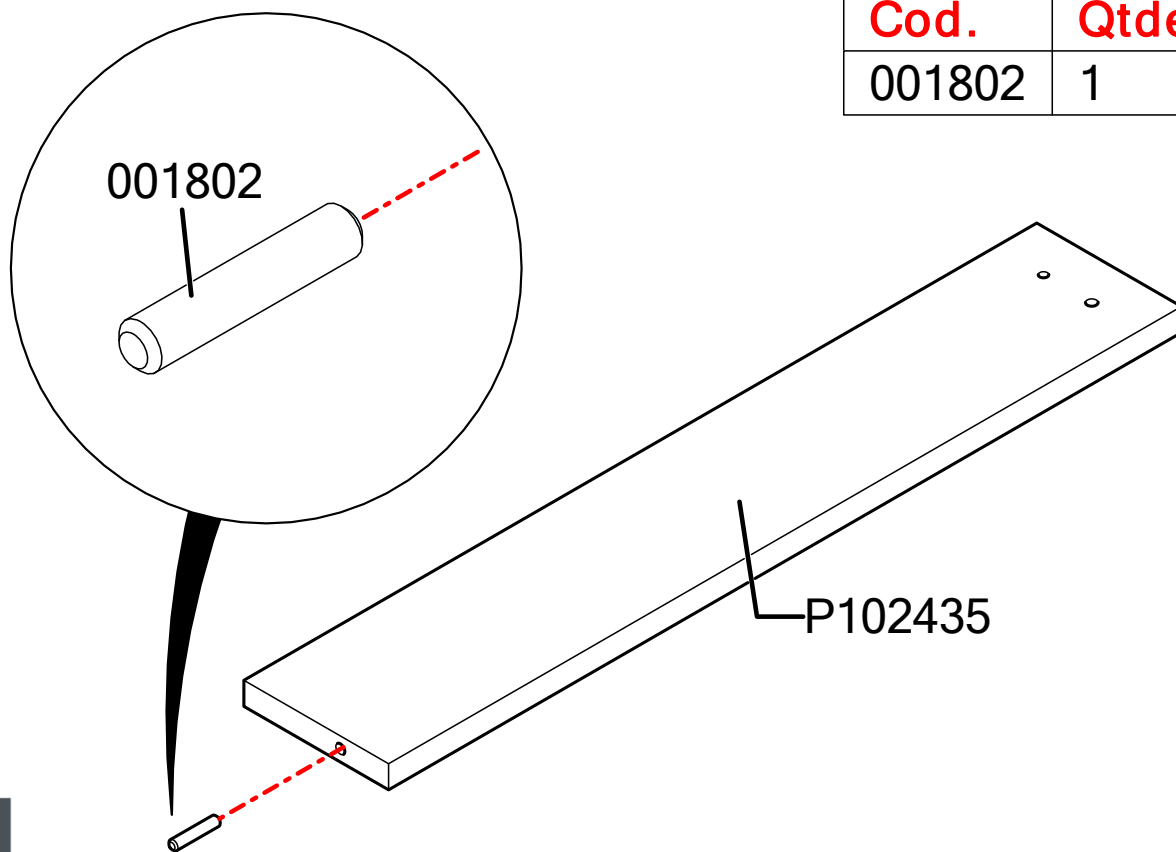

PASSO / PASO / STEP 15

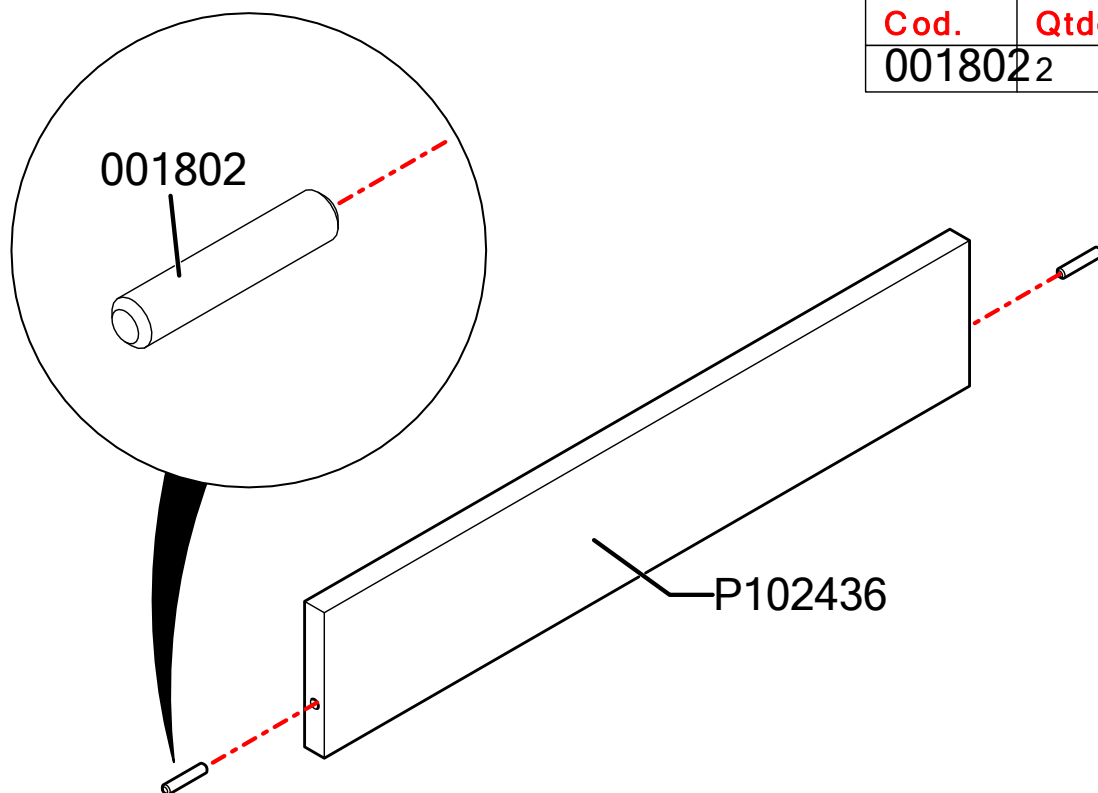

Cod.	Qtde.
001802	2

PASSO / PASO / STEP 16

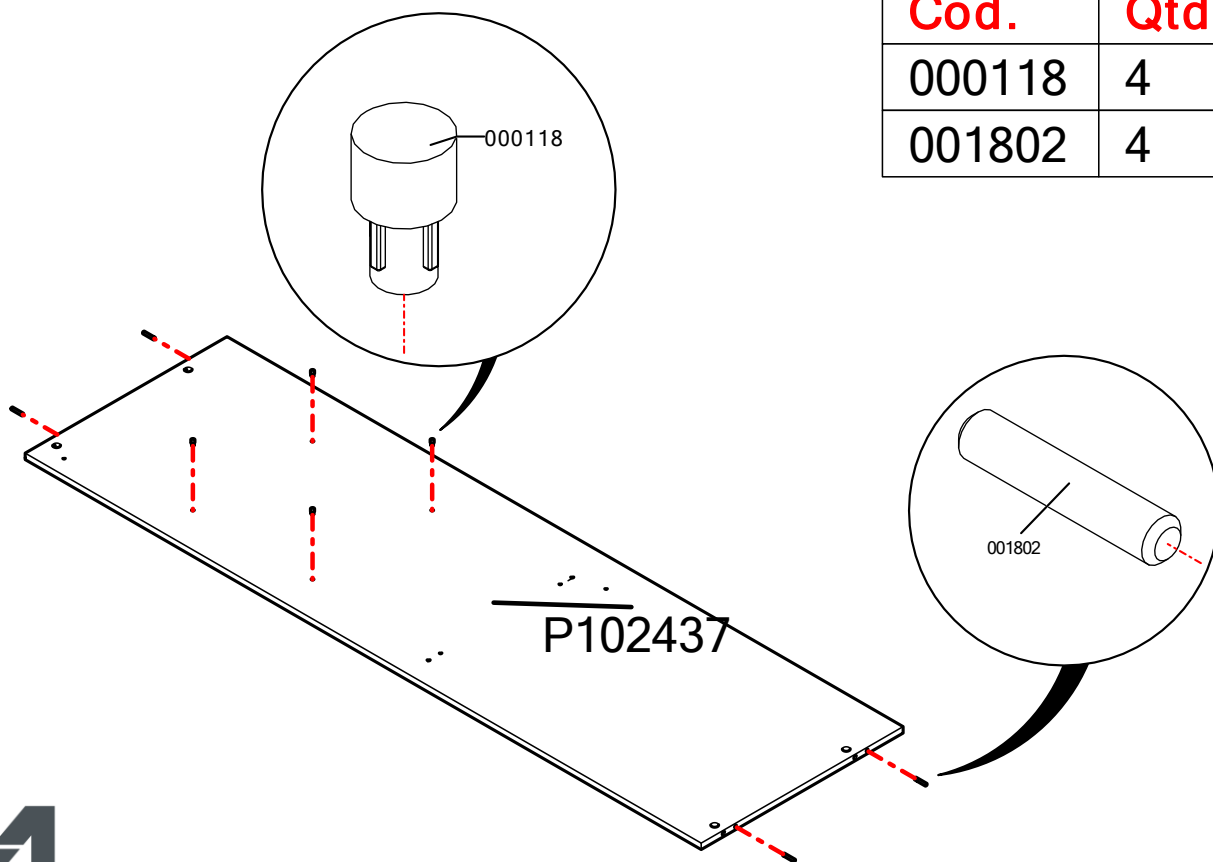

Cod.	Qtde.
000118	4
001802	4

PASSO / PASO / STEP 17

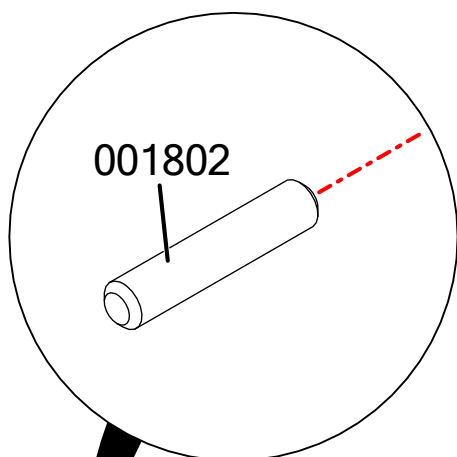

Cod.	Qtde.
001802	2

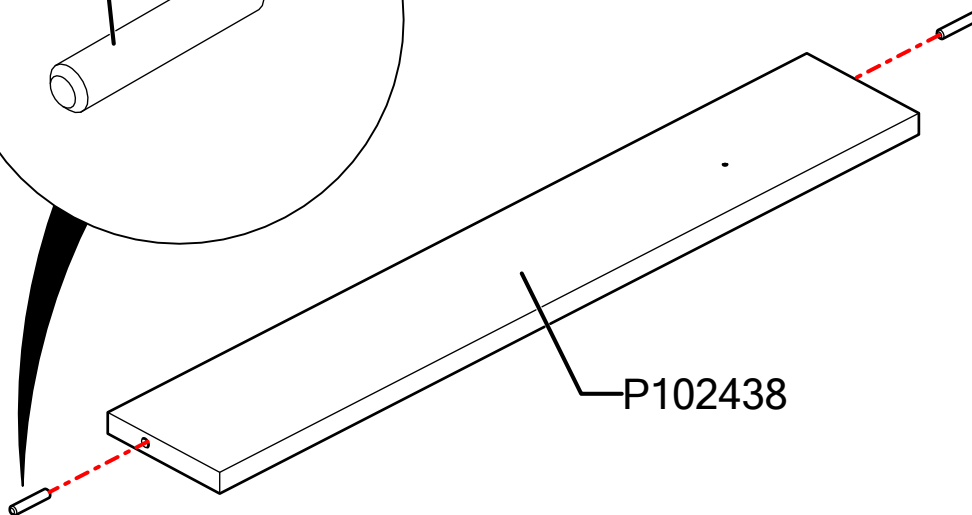

PASSO / PASO / STEP 18

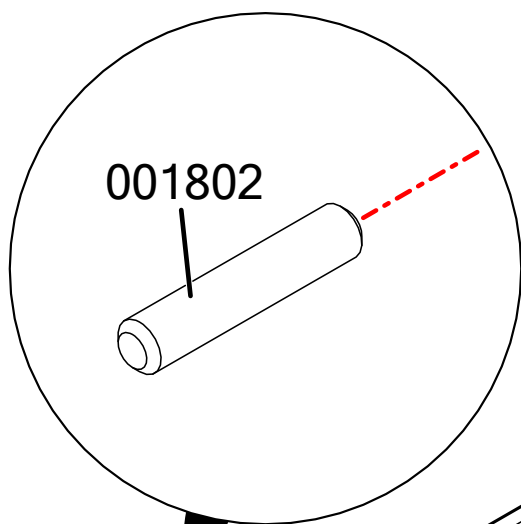

Cod.	Qtde.
001802	2

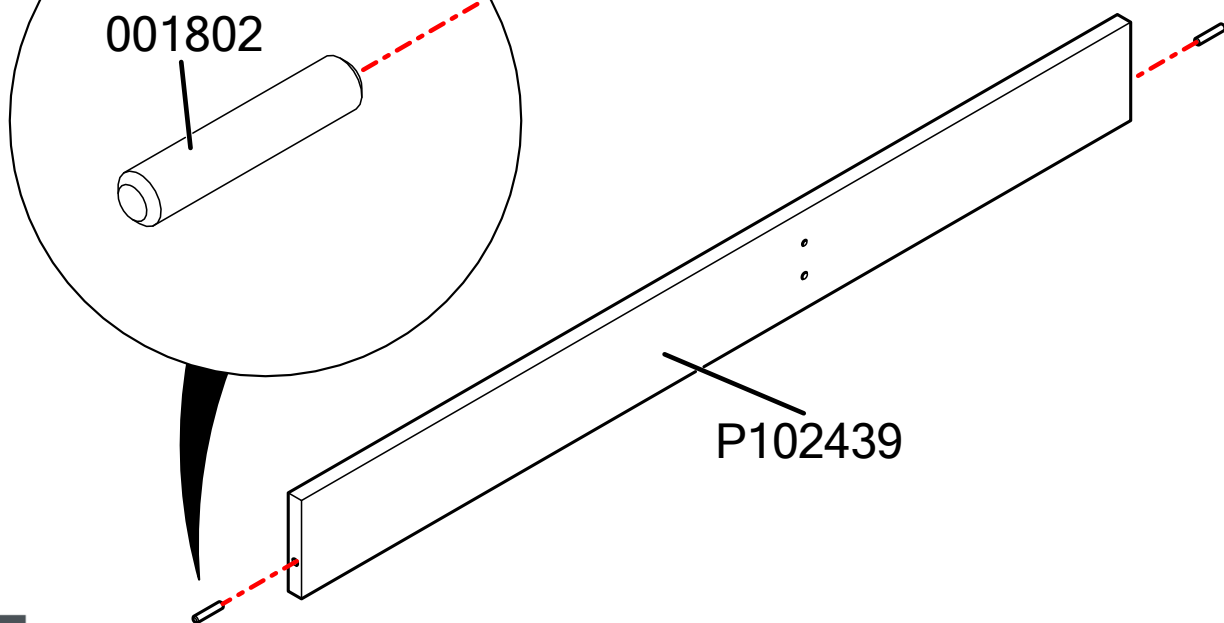

PASSO / PASO / STEP 19

Cod.	Qtde.
001802	2
004214	2
041921	1

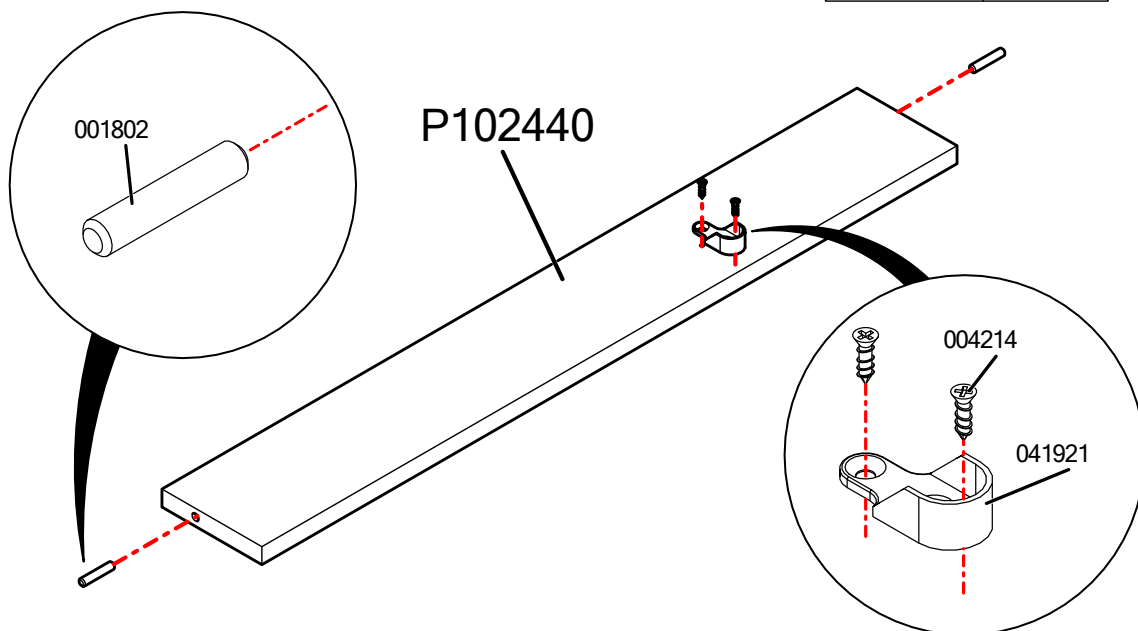

PASSO / PASO / STEP 20

Cod.	Qtde.
001802	4
030945	2

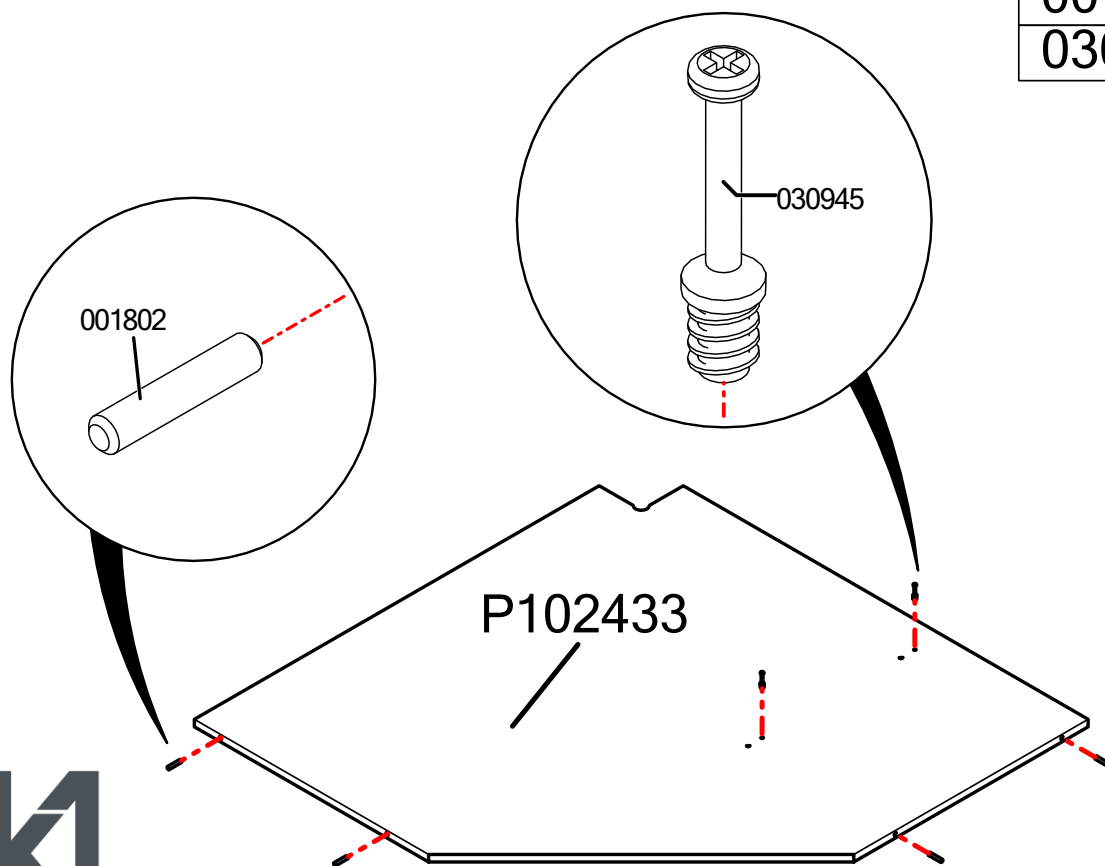

PASSO / PASO / STEP 21

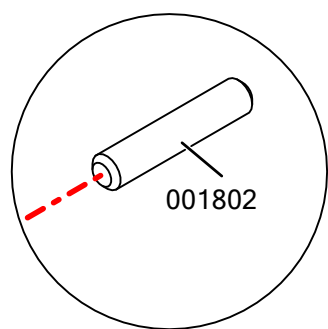

001802

P102206

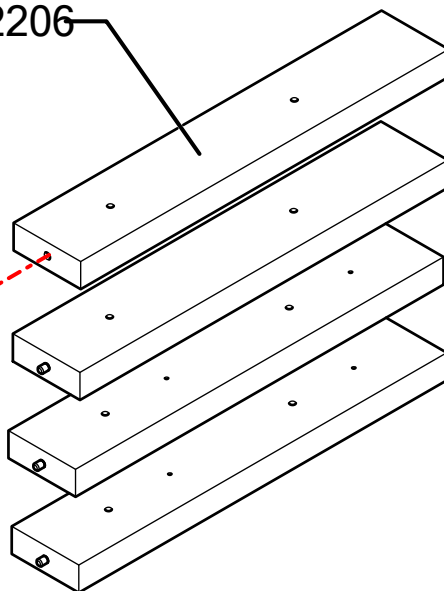

Cod.	Qtde.
001802	4

PASSO / PASO / STEP 22

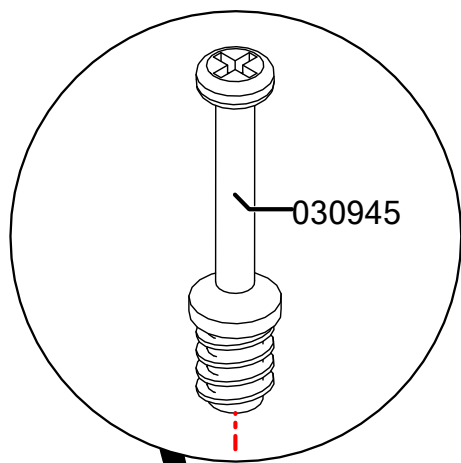

030945

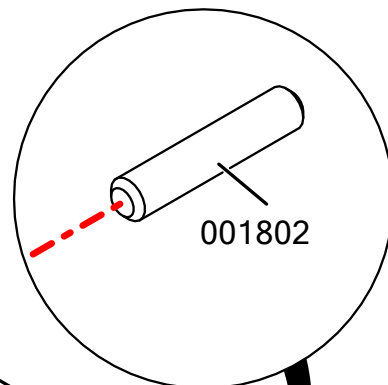

001802

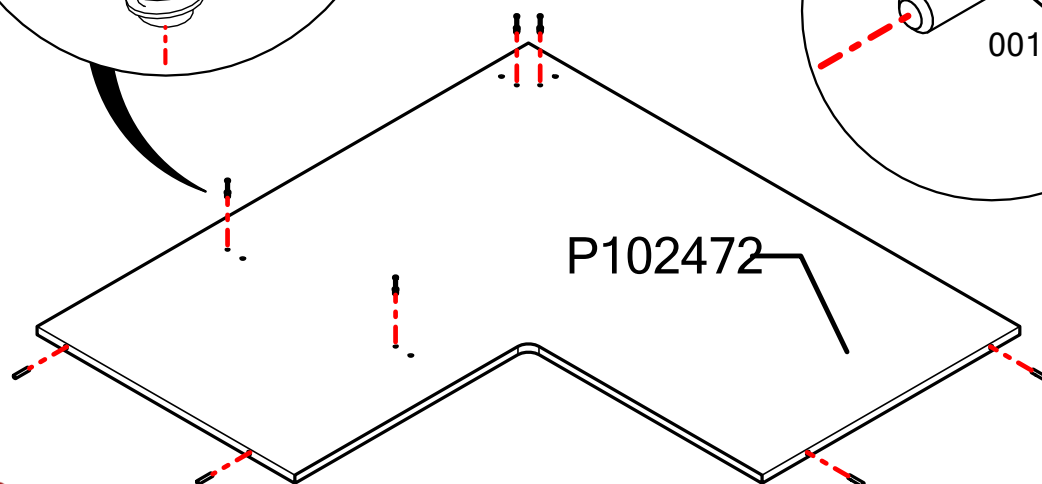

P102472

Cod.	Qtde.
001802	4
030945	4

PASSO / PASO / STEP 23

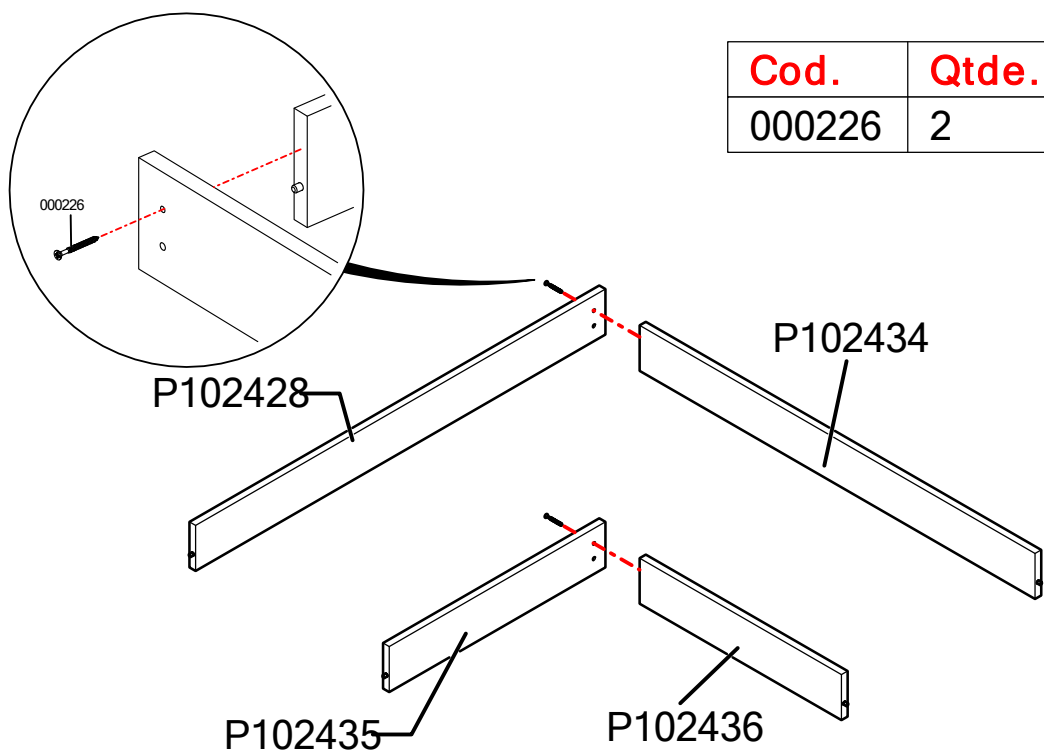

Cod.	Qtde.
000226	2

PASSO / PASO / STEP 24

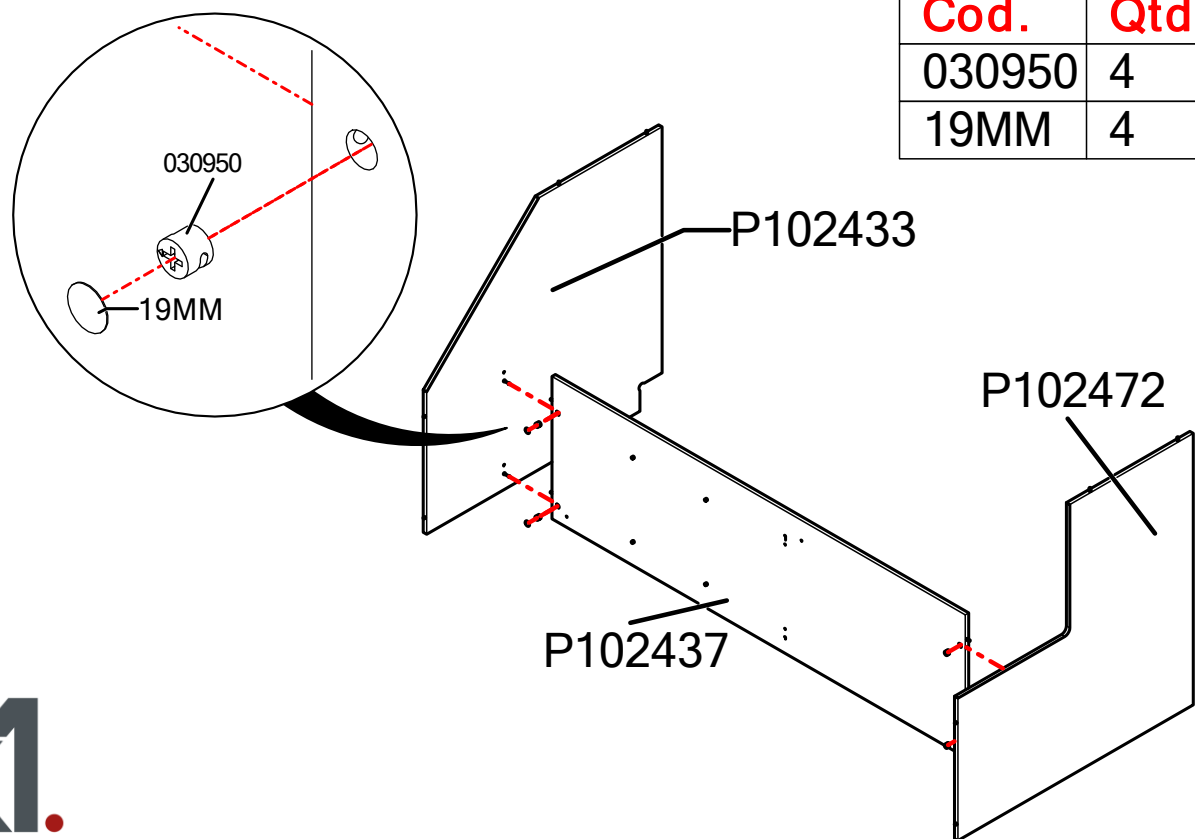

Cod.	Qtde.
030950	4
19MM	4

PASSO / PASO / STEP 25

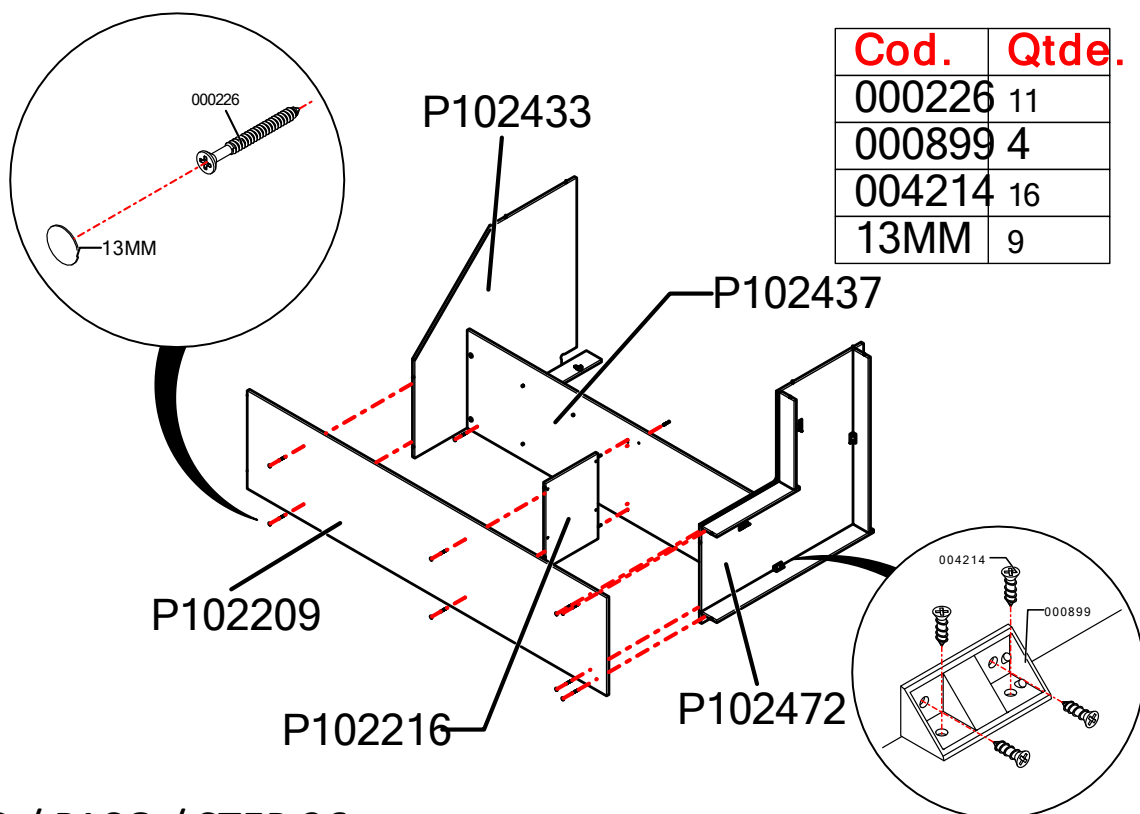

Cod.	Qtde.
000226	11
000899	4
004214	16
13MM	9

PASSO / PASO / STEP 26

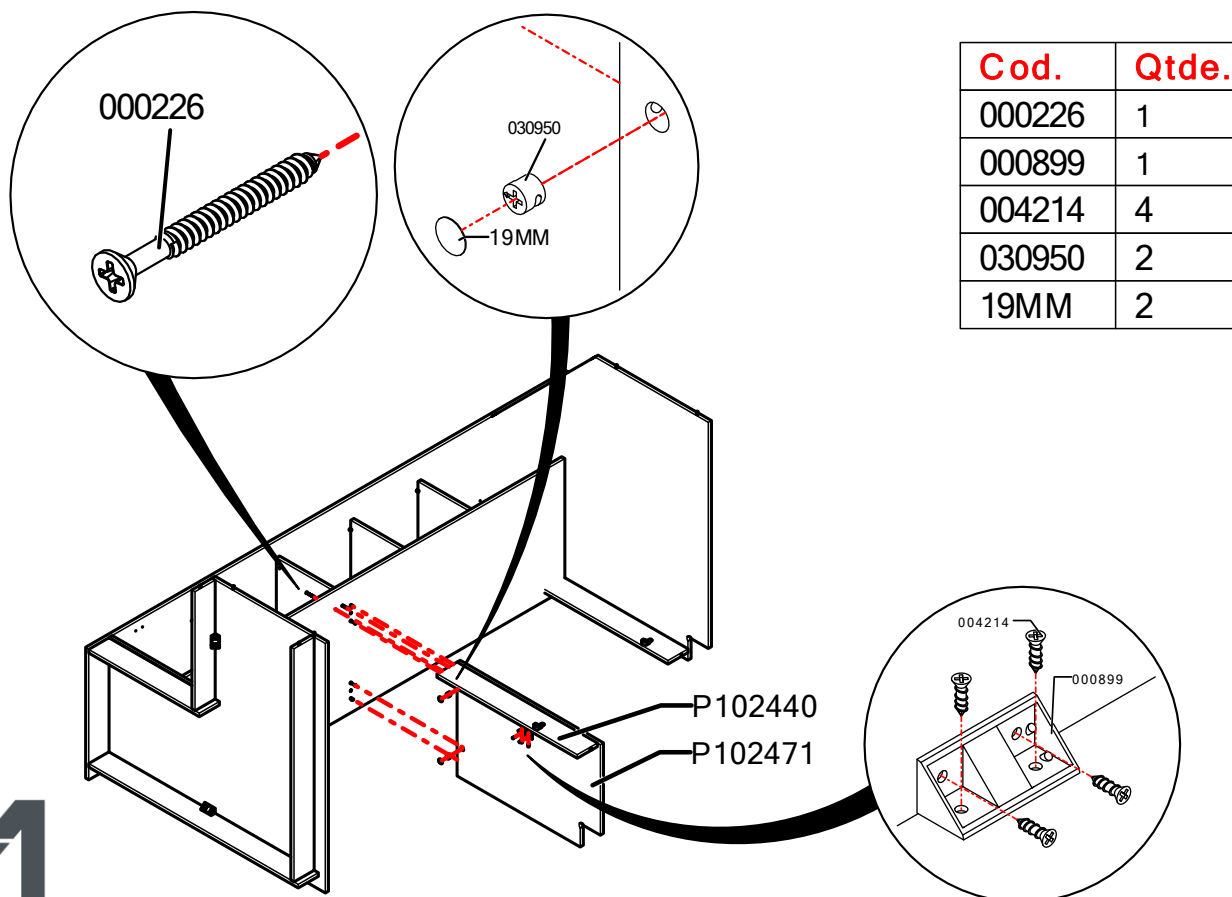

Cod.	Qtde.
000226	1
000899	1
004214	4
030950	2
19MM	2

PASSO / PASO / STEP 27

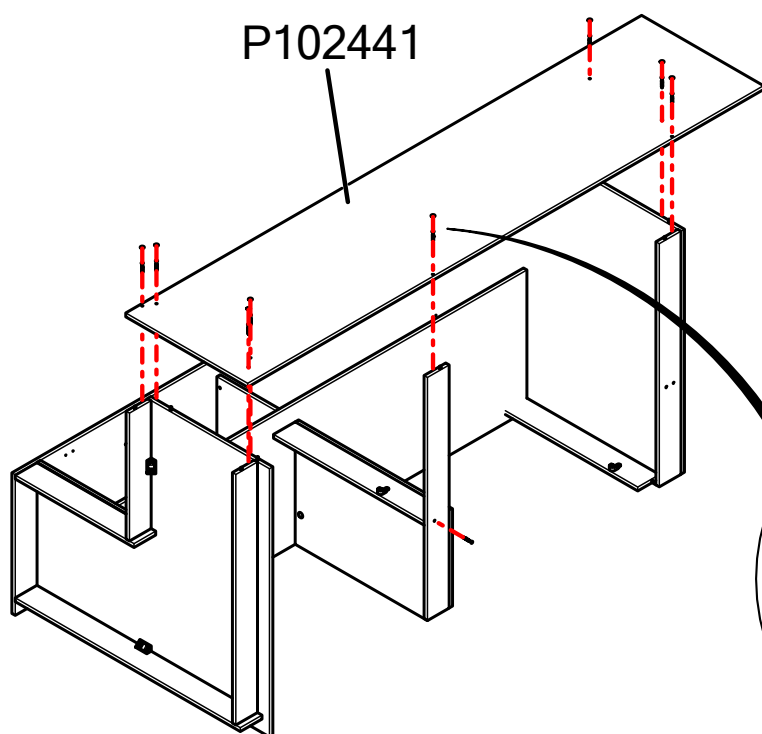

Cod.	Qtde.
000226	9
13MM	8

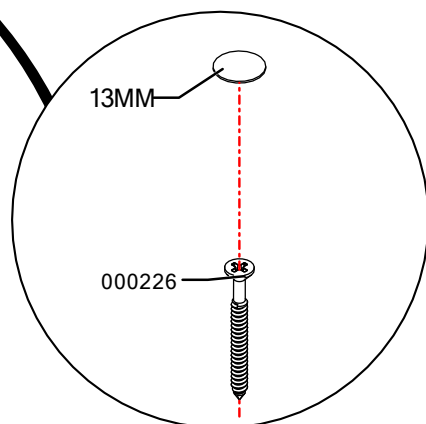

PASSO / PASO / STEP 28

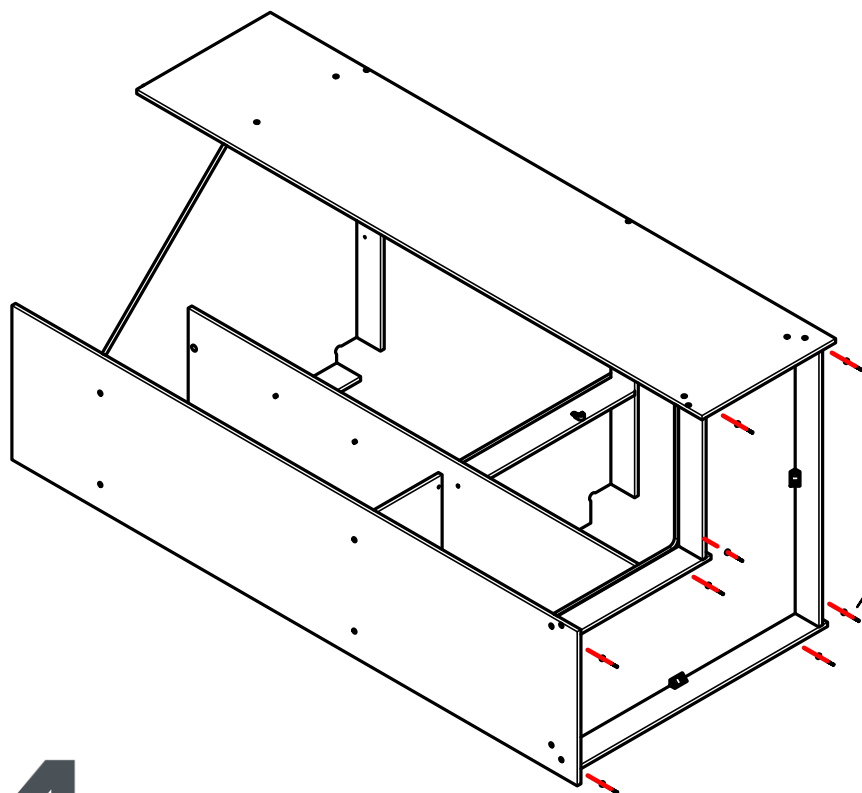

Cod.	Qtde.
000108	8
001901	8

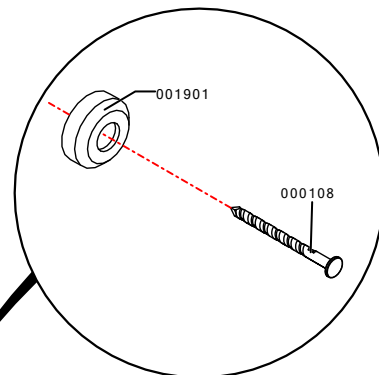

PASSO / PASO / STEP 29

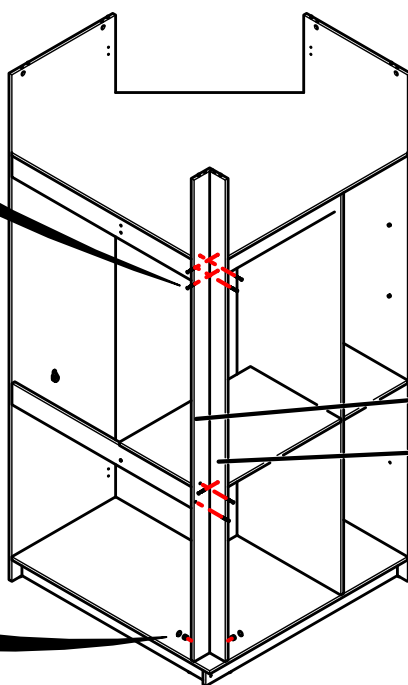
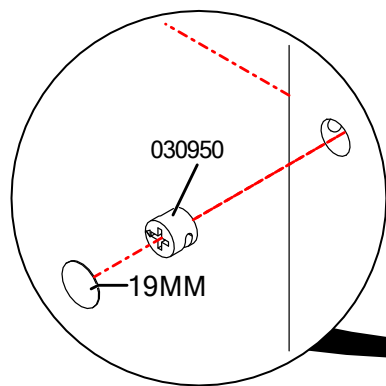
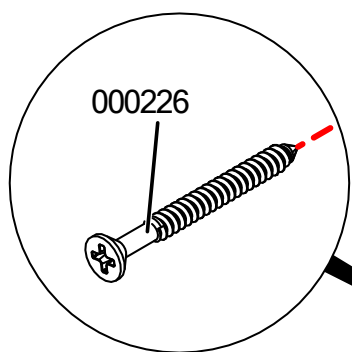

Cod.	Qtde.
000226	7
030950	2
19MM	2

P102418
P102420

PASSO / PASO / STEP 30

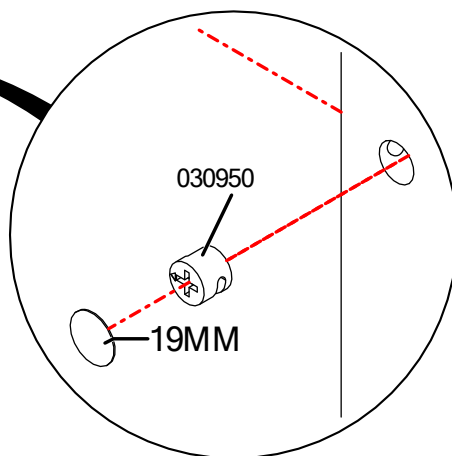
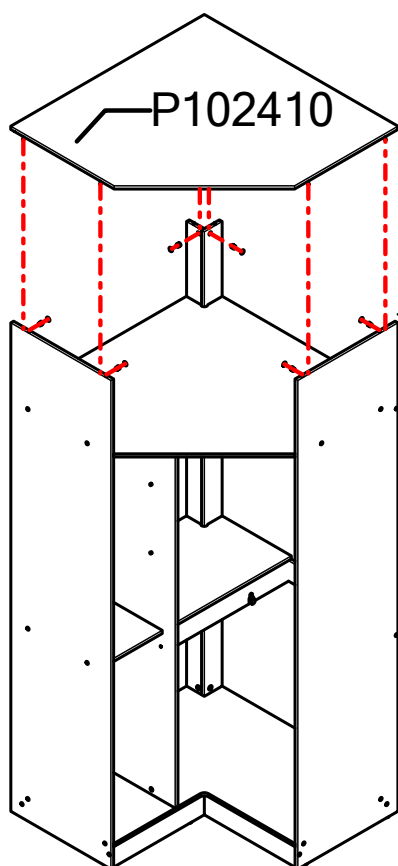

Cod.	Qtde.
030950	6
19MM	6

PASSO / PASO / STEP 31

Cod.	Qtde.
004214	8
038305	2

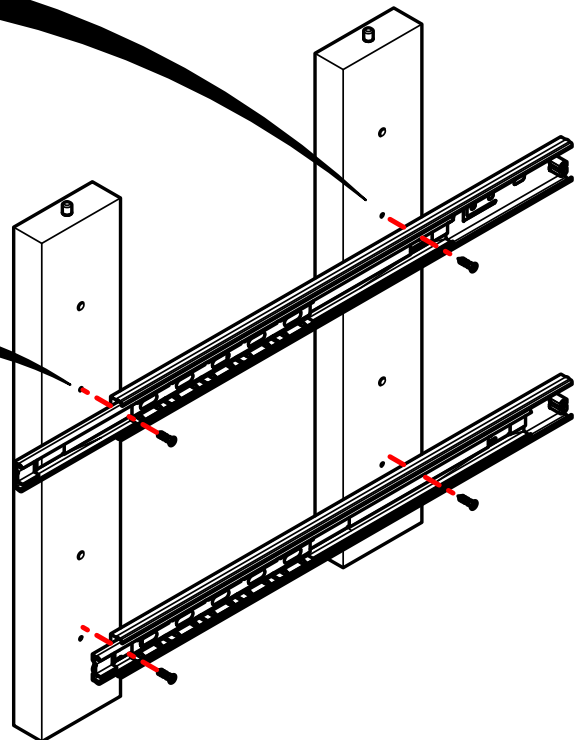
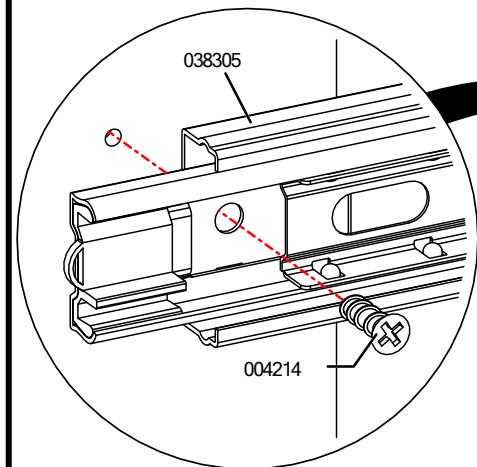
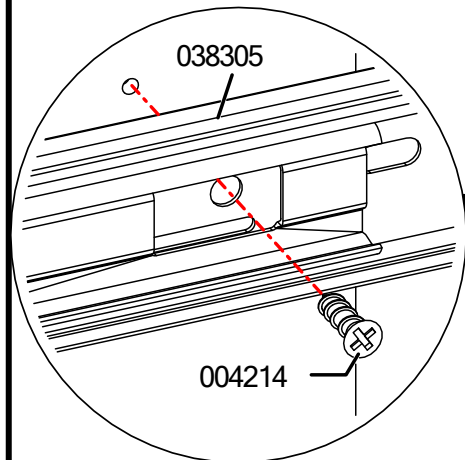

PASSO / PASO / STEP 31

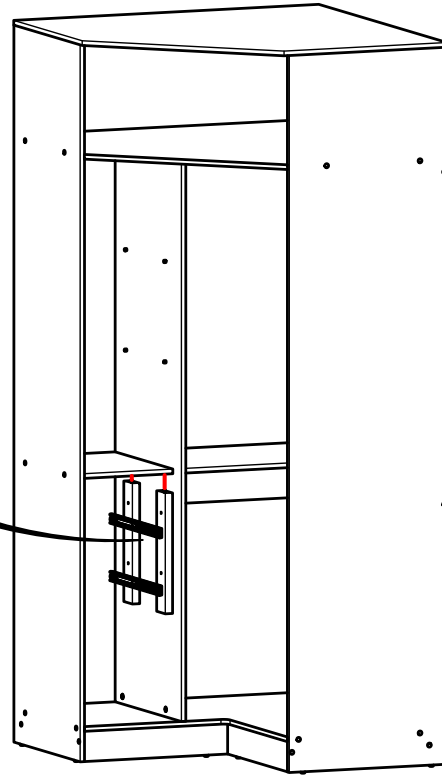
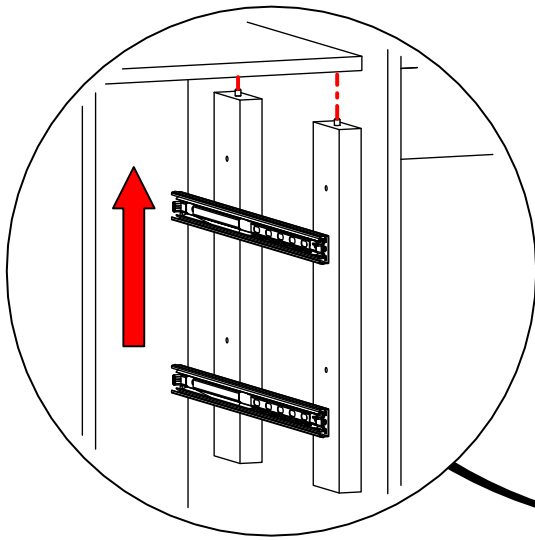

PASSO / PASO / STEP 32

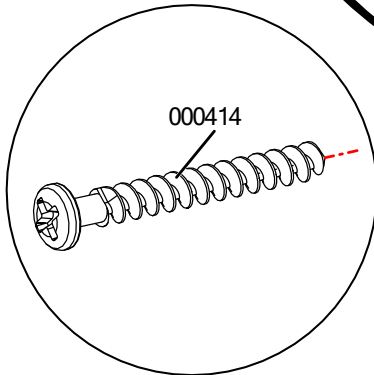
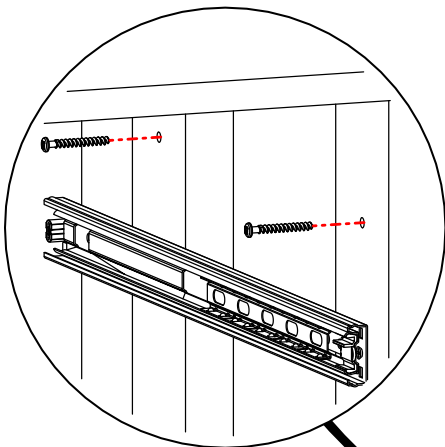

Cod.	Qtde.
000414	8

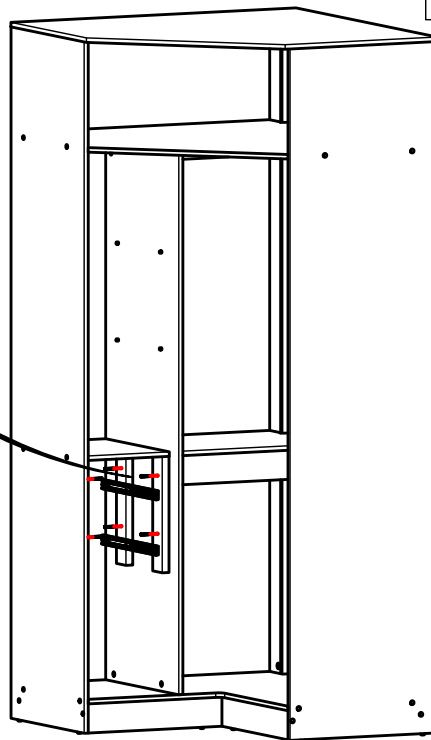

PASSO / PASO / STEP 33

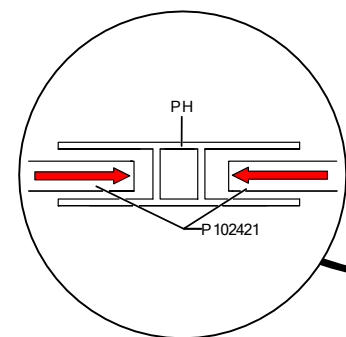

Cod.	Qtde.
000107	168
PH	2

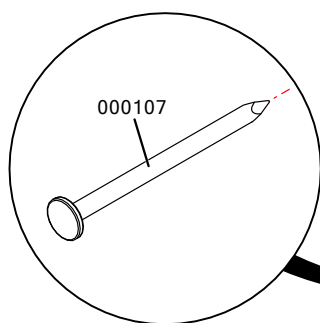

P102421

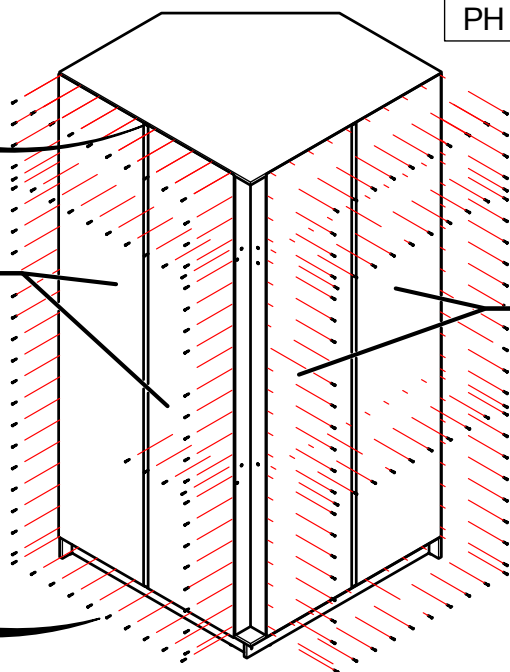

P102421

PASSO / PASO / STEP 34

P102213

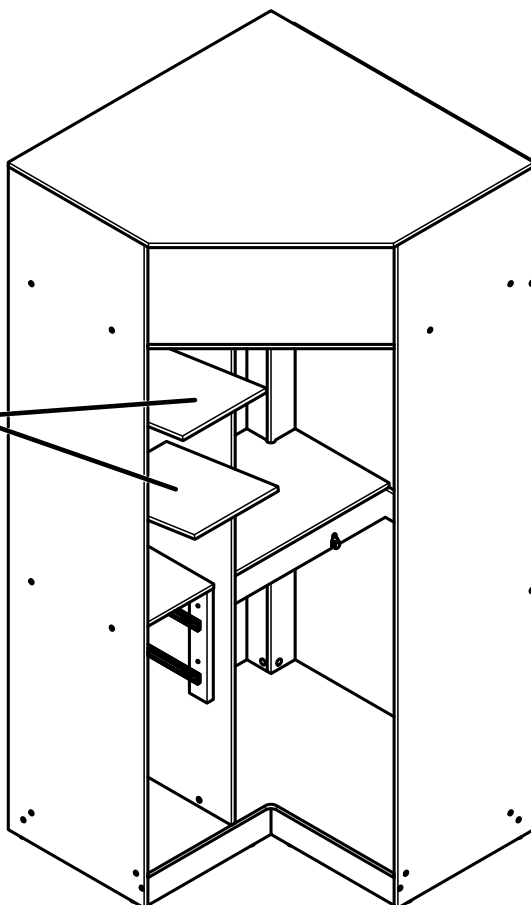

PASSO / PASO / STEP 35

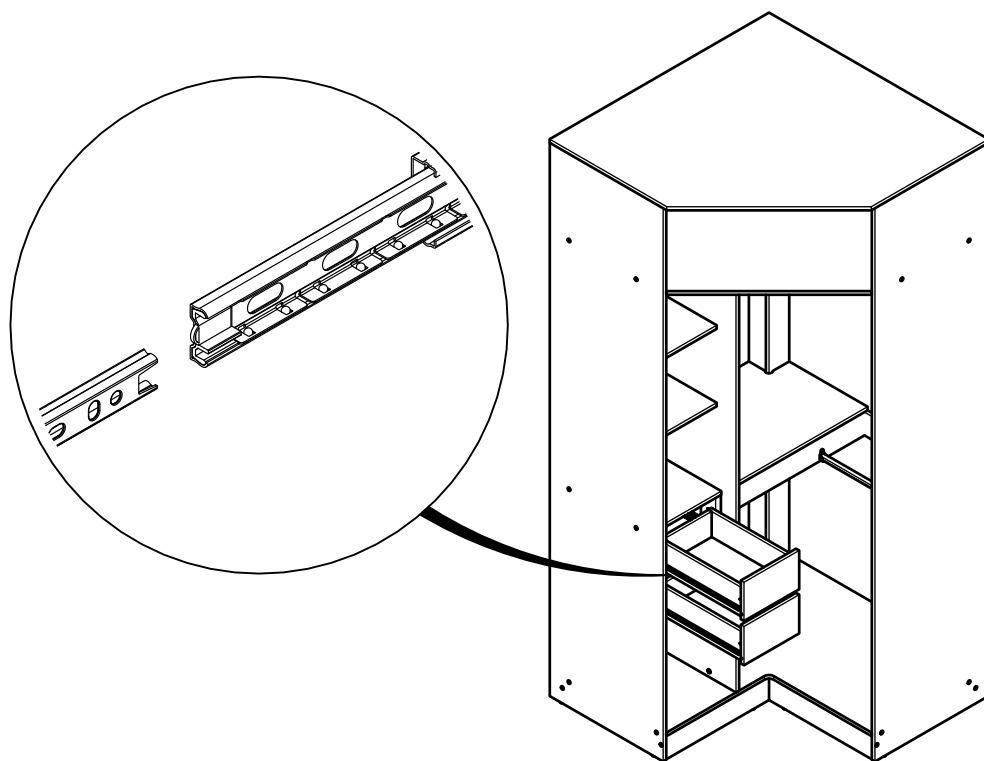

PASSO / PASO / STEP 36

Cod.	Qtde.
054117	4

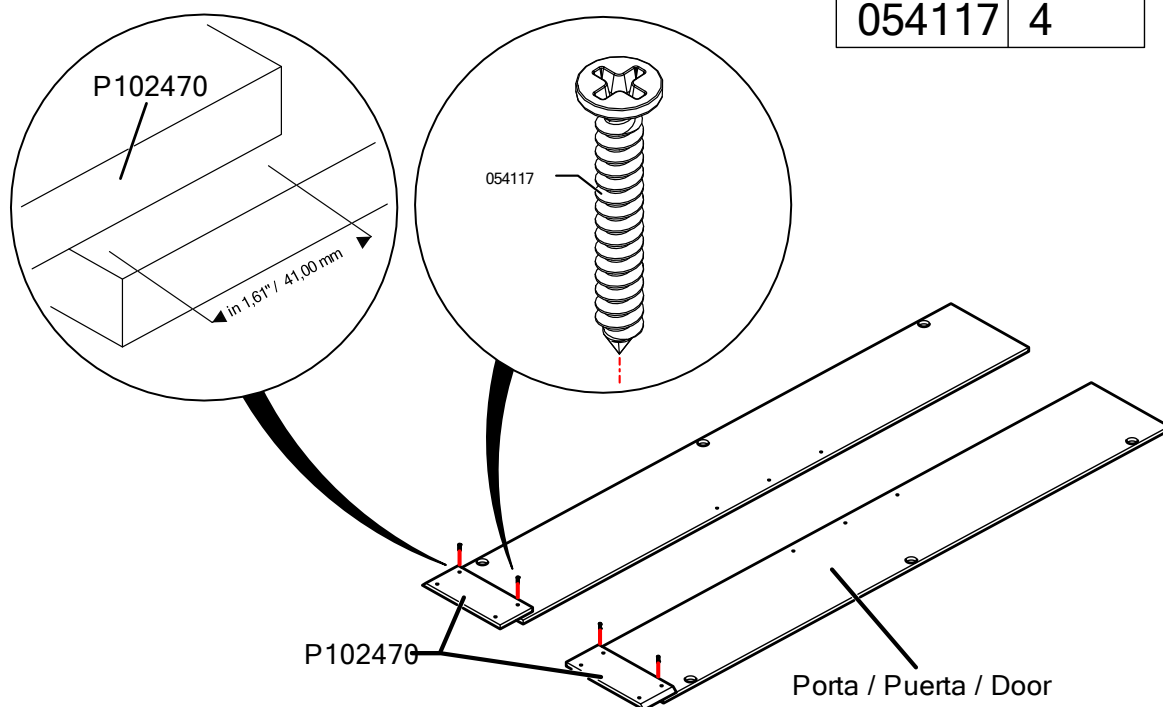

PASSO / PASO / STEP 37

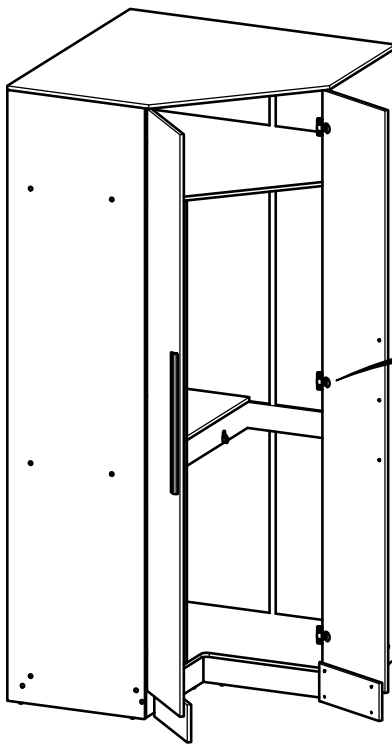

Cod.	Qtde.
015021	6
061971	24

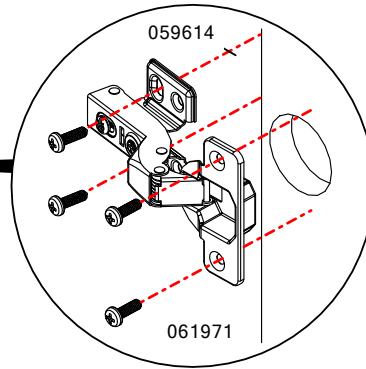

PASSO / PASO / STEP 38

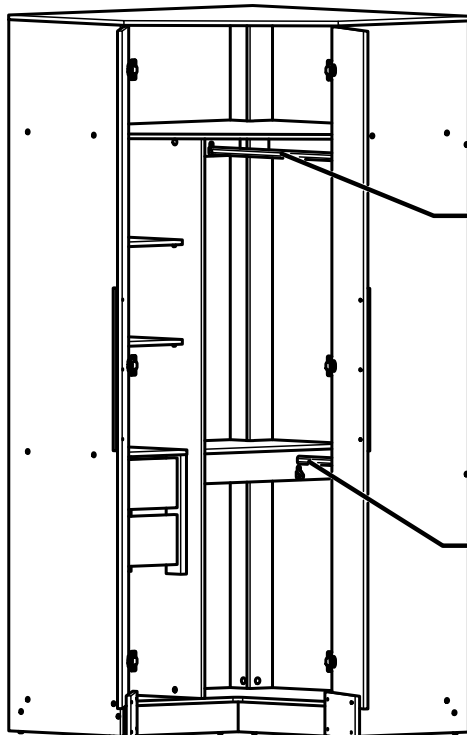

Cod.	Qtde.
076864	1
076865	1

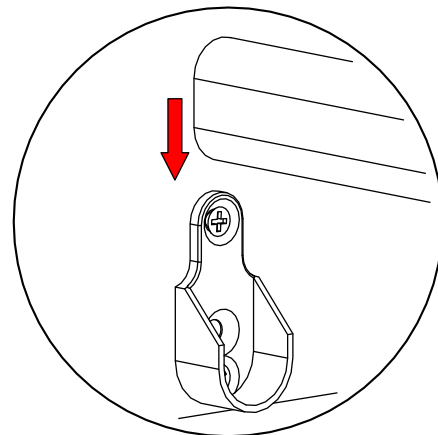

076864

076865

Manual de montagem

Instrucciones de montaje Assembly instructions

ARMC105AMDP

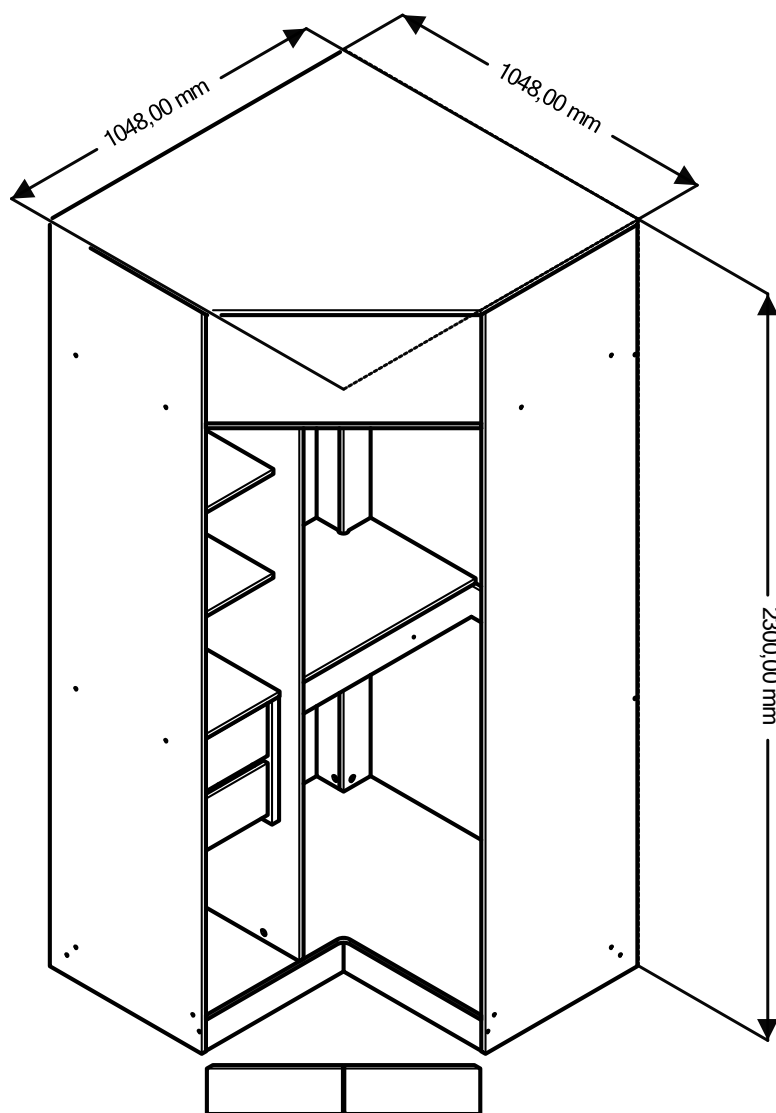

! Imagens meramente ilustrativas !
Imágenes ilustrativas/Images merely illustrative.

Dúvidas? Entre em contato:
Dudas? Ponerse em contacto:
Doubts? Get in touch:
(51) 3635-8839

A montagem deve ser efetuada por 2 pessoas.

El montaje debe ser efectuada por 2 personas.

The assembly must be done by 2 people.

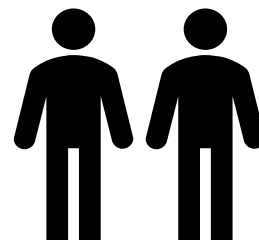

Ferramentas necessárias para montar o móvel.

Herramientas necesarias para armar el mueble.

Tools needed to assemble the furniture.



Dúvidas? Entrar em contato:

Dudas? Ponerse en contacto:

Doubts? Get in touch:

Fone: (51) 3635-8839

www.kappesberg.com.br



Montar o móvel sobre uma superfície limpa e plana.

Armar el mueble sobre una superficie limpia y plana.

Assemble the furniture on a clean, flat surface.

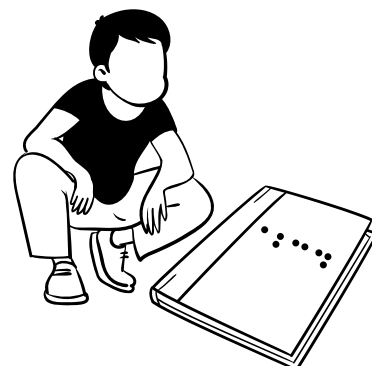

**IDENTIFICAÇÃO DAS PEÇAS / IDENTIFICACIÓN DE LAS PIEZAS PARTS
IDENTIFICATION**

Quantidade Cantidad Amount	Código Code	Descrição	Descripción	Description	C x L x E	L x W x T
2	P102213	PRATELEIRA	ESTANTE	SHELF	332 x 448 x 15 mm	13.07 x 17.64 x 0.59 in
1	P102216	TAMPO DE GAVETA	TAPA DEL CAJON	TOP OF DRAWERS	332 x 470 x 15 mm	13.07 x 18.50 x 0.59 in
1	P102410	CHAPÉU	SOMBRERO	HAT	1045 x 1045 x 15 mm	41.14 x 41.14 x 0.59 in
1	P102209	LATERAL ESQUERDA	LADO IZQUERDA	LEFT SIDE	2285 x 540 x 15 mm	89.96 x 21.26 x 0.59 in
4	P102421	COSTA	COSTA	COAST	2194 x 474 x 3 mm	86.38 x 18.66 x 0.12 in
1	P102441	LATERAL DIREITA	LADO DIRECTO	RIGHT SIDE	2285 x 540 x 15 mm	89.96 x 21.26 x 0.59 in
1	P102420	SARRAFO	LISTÓN	SLAT	2173 x 81 x 15 mm	85.55 x 3.19 x 0.59 in
1	P102418	SARRAFO	LISTÓN	SLAT	2173 x 96 x 15 mm	85.55 x 3.78 x 0.59 in
1	P102472	BASE	BASE	BASE	1030 x 1030 x 15 mm	40.55 x 40.55 x 0.59 in
1	P102435	RODAPE	ZOCALO	BASEBOARD	526 x 96 x 15 mm	20.71 x 3.78 x 0.59 in
1	P102437	DIVISORIA	DIVISION	DIVISION	1808 x 540 x 15 mm	71.18 x 21.26 x 0.59 in
4	P102202	LATERAL DE GAVETA	LADO DEL CAJÓN	DRAWER SIDE	400 x 120 x 15 mm	15.75 x 4.72 x 0.59 in
2	P102204	FUNDO DE GAVETA	FONDO DEL CAJÓN	DRAWER BOTTOM	241 x 398 x 3 mm	9.49 x 15.67 x 0.12 in
2	P102203	CABECEIRA DE GAVETA	CABEZAL DEL CAJÓN	DRAWER HEAD	228 x 120 x 15 mm	8.98 x 4.72 x 0.59 in
2	P102207	FRENTE DE GAVETA	FRENTE DEL CAJÓN	DRAWER FRONT	263 x 160 x 15 mm	10.35 x 6.30 x 0.59 in
4	P102206	AFASTADOR	RETRACTOR	SEPARADOR	384 x 70 x 25 mm	15.12 x 2.76 x 0.98 in
1	P102471	TAMPO DE GAVETA / USINADA	TAPA DEL CAJON	TOP OF DRAWERS	682 x 470 x 15 mm	26.85 x 18.50 x 0.59 in
1	P102433	BASE DO MALEIRO / USINADA	BASE	BASE	1030 x 1030 x 15 mm	40.55 x 40.55 x 0.59 in
1	P102438	SARRAFO	LISTÓN	SLAT	587 x 96 x 15 mm	23.11 x 3.78 x 0.59 in
1	P102428	RODAPE	ZOCALO	BASEBOARD	997 x 96 x 15 mm	39.25 x 3.78 x 0.59 in
1	P102436	RODAPE	ZOCALO	BASEBOARD	491 x 96 x 15 mm	19.33 x 3.78 x 0.59 in
1	P102434	RODAPE	ZOCALO	BASEBOARD	962 x 96 x 15 mm	37.87 x 3.78 x 0.59 in
2	P102439	SARRAFO	LISTÓN	SLAT	934 x 96 x 15 mm	36.77 x 3.78 x 0.59 in
1	P102440	SARRAFO	LISTÓN	SLAT	668 x 96 x 15 mm	26.30 x 3.78 x 0.59 in
2	P102470	RODAPE	ZOCALO	BASEBOARD	342 x 140 x 15 mm	13.46 x 5.51 x 0.59 in

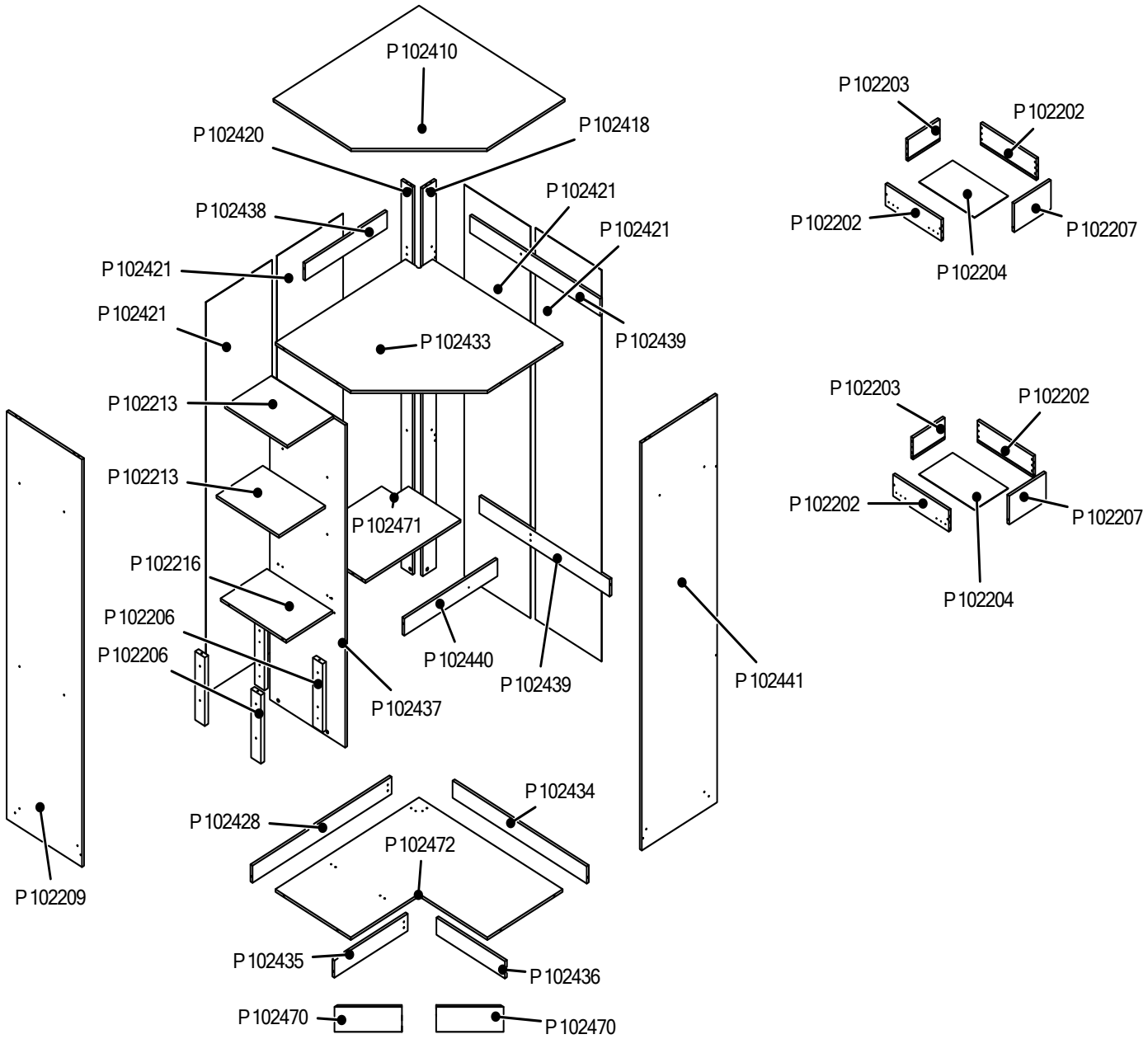











IDENTIFICAÇÃO DOS ACESSÓRIOS / IDENTIFICACIÓN DE ACCESORIOS IDENTIFICATION OF ACCESSORIES

NOTAS: A separação dos acessórios antes de iniciar a montagem facilitará a mesma. Em caso de dúvida na identificação, coloque o acessório sobre a régua.

Nota: Separar los accesorios antes de iniciar el montaje facilitará el mismo. En caso de duda en la identificación, coloque el accesorio en la regla.

NOTE: Separating the accessories before starting assembly will make it easier. In case of doubt in the identification, place the accessory on the ruler.

	Quantidade / Cantidad / Amount	Código / Code	Descrição	Descripción	Description
	2	PX	PUX. REVESTIDO DOURADO FX120 522MM (224MM EF)	MANILLA DE PUERTA 522MM	PULLER 522MM
	17	054117	P.CHATO 3,5 X 25 CAB. PHILLIPS ZB/BC (IDELLI)	TORNILLO 3,5 X 25	SCREW 3,5 X 25
	56	001802	CAVILHAS DE MADEIRA 6X30 PINUS	TARUGO 6X30MM	DOWEL 6X30MM
	14	030950	TAMBOR P/ MINIFIX 15MM ZAMAQ 09.11.007	CILINDRO 15MM	BARREL 15MM
	14	030945	PARAFUSO DE ACO P/ MINIFIX	TORNILLO DE ACERO PARA MINIFIX	STEEL SCREW FOR MINIFIX
	34	000226	P.CHATO 4,0 X 40MM	TORNILLO 4,0 X 40MM	SCREW 4,0 X 40MM
	8	000118	SUP. P/ PRAT. 6 X 8MM BEGE (COR 004)	SOPORTE DE ESTANTE 6 X 8	SHELF SUPPORT 6 X 8
	2	001925	CAVILHA 6 X 50MM MADEIRA	TARUGO 6 X 50MM	DOWEL 6 X 50MM
	168	000107	PREGO 10 X 10 (0,308G) LISO	CLAVO 10 X 10	NAIL 10 X 10
	69	004214	P.CHATO 3,5 X 14 CAB. PHILLIPS REBAIXADA ZB	TORNILLO 3,5 X 14MM	SCREW 3,5 X 14MM
	9	000899	CANTONEIRA PLASTICA PRETA	CANTONERA	PLASTIC HANDLE

IDENTIFICAÇÃO DOS ACESSÓRIOS / IDENTIFICACIÓN DE ACCESORIOS IDENTIFICATION OF ACCESSORIES

	1	076864	ROLICO OBLONGO 15X25MM ALUMINIO NATURAL FRISADO 976MM	ROLICO OBLONGO 15X25MM ALUMINIO NATURAL FRISADO 976MM	ROLICO OBLONGO 15X25MM ALUMINIO NATURAL FRISADO 976MM
	1	076865	ROLICO OBLONGO 15X25MM ALUMINIO NATURAL FRISADO 553MM	ROLICO OBLONGO 15X25MM ALUMINIO NATURAL FRISADO 553MM	ROLICO OBLONGO 15X25MM ALUMINIO NATURAL FRISADO 553MM
	17	13MM	TAPA FURO 13MM	TAPA DEL AGUJERO 13MM	SCREW CAP COVER 13MM
	12	19MM	TAPA FURO 19MM	TAPA DEL AGUJERO 19MM	SCREW CAP COVER 19MM
	24	061971	P.PANELA 4,0 X 14 ZB P/DOBRADICA	TORNILLO 4,0 X 14	SCREW 4,0 X 14
	6	015021	DOBRAD. 35MM 45°	BISAGRA 35MM 45°	HINGE 35MM 45°
	8	001901	SAPATA DESLIZADORA PRETA 15 X 6 (02.02.026)	ZAPATO 15 X 6	SHOE 15 X 6
	8	000108	PREGO 12 X 12 (0,6127G) ARDOX	CLAVO 12 X 12	NAIL 12 X 12
	4	041921	SUP. P/ CABIDEIRO OBLONGO METAL COR ALU. ESCURO	SOPORTE PERCHA	CLOTHES RACK
	2	038305	CORREDICA TELESCOPICO MINI LIGHT (H32/30) 400MM	CORREDICA TELESCOPICO MINI LIGHT (H32/30) 400MM	CORREDICA TELESCOPICO MINI LIGHT (H32/30) 400MM
	8	000414	P.PANELA 4,0 X 35 CAB. PHILLIPS ZB/BC	TORNILLO 4,0 X 35	SCREW 4,0 X 35
	4	018458	SUPORTE TRIANGULAR PRETO	SOPORTE TRIANGULO NEGRO	BLACK TRIANGLE SUPPORT
	4	005256	PARAFUSO CHATO 4,0 X 20 BC	TORNILLO PLANO 4,0 X 20 BC	FLAT SCREW 4,0 X 20 BC
	2	075246	PERF. H26 2190MM	PERFIL H 2190MM	PROFILE H 2190MM

INSTALAÇÃO MINIFIX

Identificar seta no corpo do tambor de minifix. A seta DEVE apontar para o buraco na borda do painel. Empurrar o tambor até o buraco.

INSTALACIÓN DE LA LEVA

Identifique la flecha en los muertos de la leva. La flecha debe apuntar hacia el agujero en el borde del panel. Empuje la leva hasta el fondo del orificio.

INSTALLING CAM

Identify arrow on head of cam. Arrow MUST point toward hole in edge of panel. Push cam all the way down into hole.

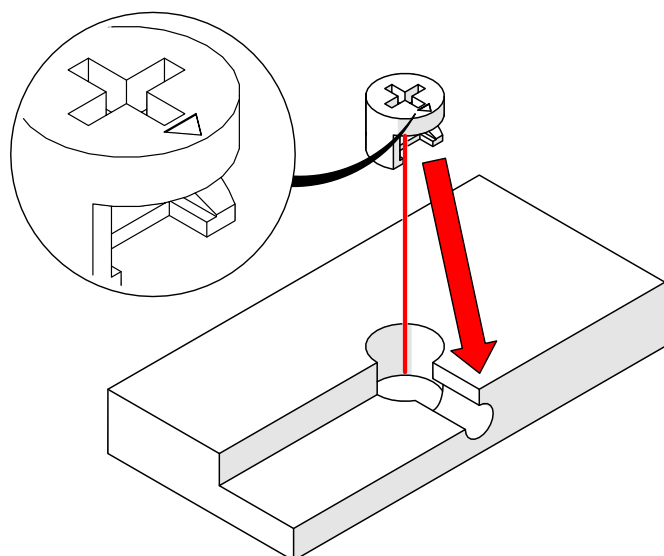

ALINHAMENTO DO TAMBOR E PARAFUSO

A seta do tambor de minifix deve ser aponta para o buraco e inserir o parafuso do minifix do tambor contido no buraco. Certifique-se de que as peças se unam.

ALINEACIÓN DE LA LEVA Y EL PASADOR

Asegúrese de que la flecha de la leva apunte hacia el orificio e inserte la clavija de la leva en el orificio. Asegúrese de que las piezas se unen.

CAM AND DOWEL ALIGNMENT

Ensure the arrow on the cam points toward hole and insert cam dowel into hole. Make sure pieces join together.

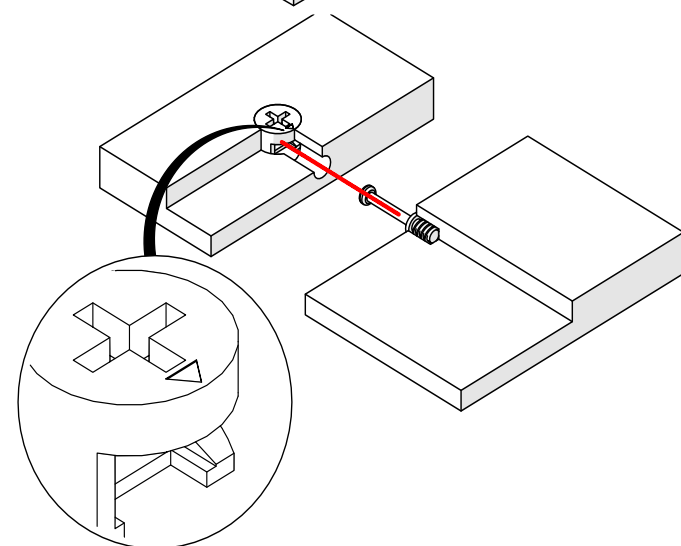

CÂMARA DE COMPENSAÇÃO DE TENSÃO

Use uma chave de fenda para girar a came. Girar o tambor minifix (no sentido horário) até que esteja totalmente apertado. Ligeiramente mais de meia volta.

APRIETE DE LA LEVA

Utilice un destornillador para girar la leva. Gire la leva (en el sentido de las agujas del reloj) hasta que esté completamente apretada. Un poco más de media vuelta.

TIGHTENING CAM

Use screwdriver to turn cam. Turn cam (clockwise) until fully tightened. Slightly more than half a turn.

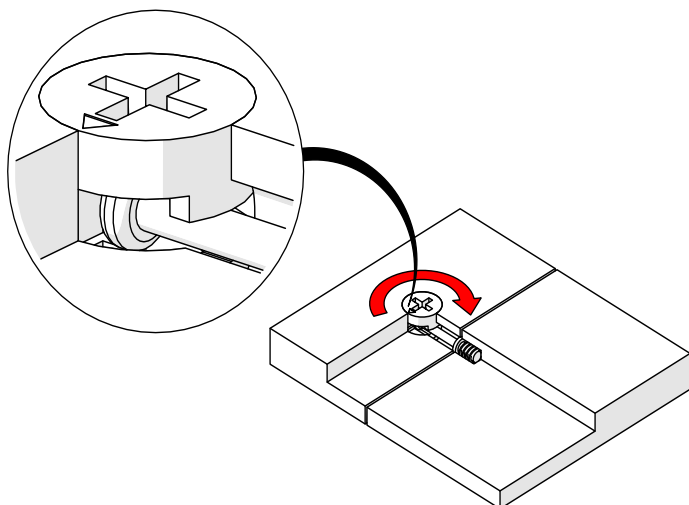

PASSO / PASO / STEP 1

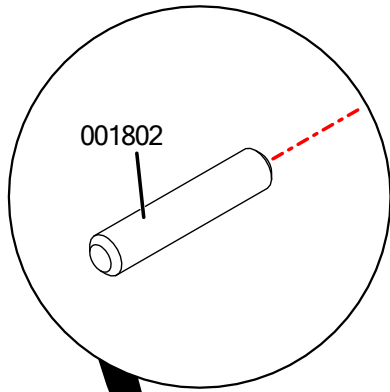

Cod.	Qtde.
001802	8

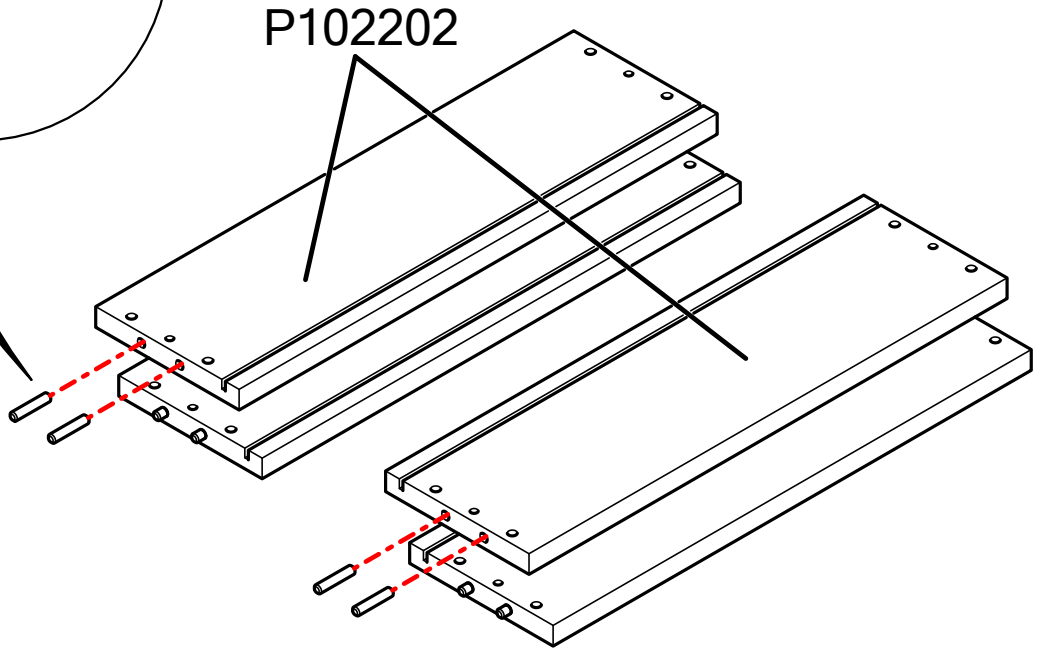

Cod.	Qtde.
001802	8

PASSO / PASO / STEP 2

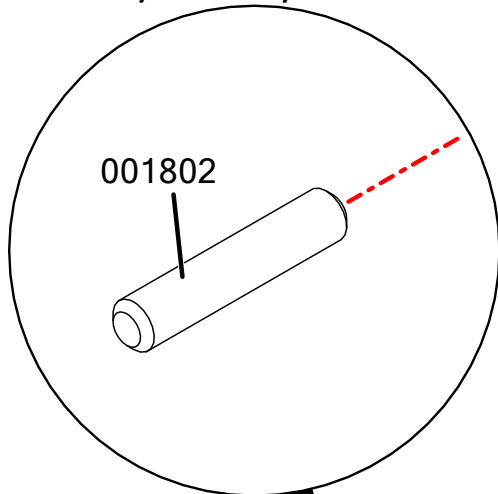

P102203

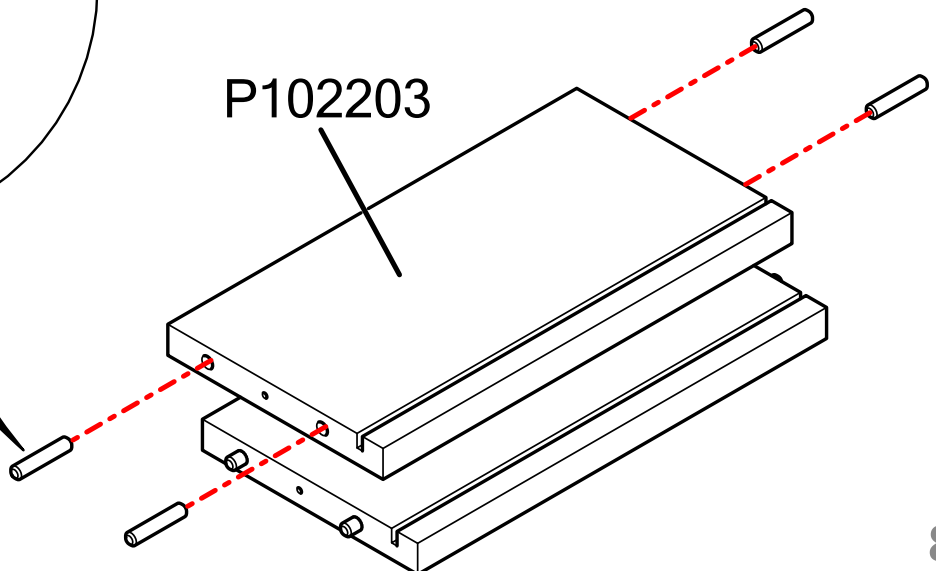

PASSO / PASO / STEP 3

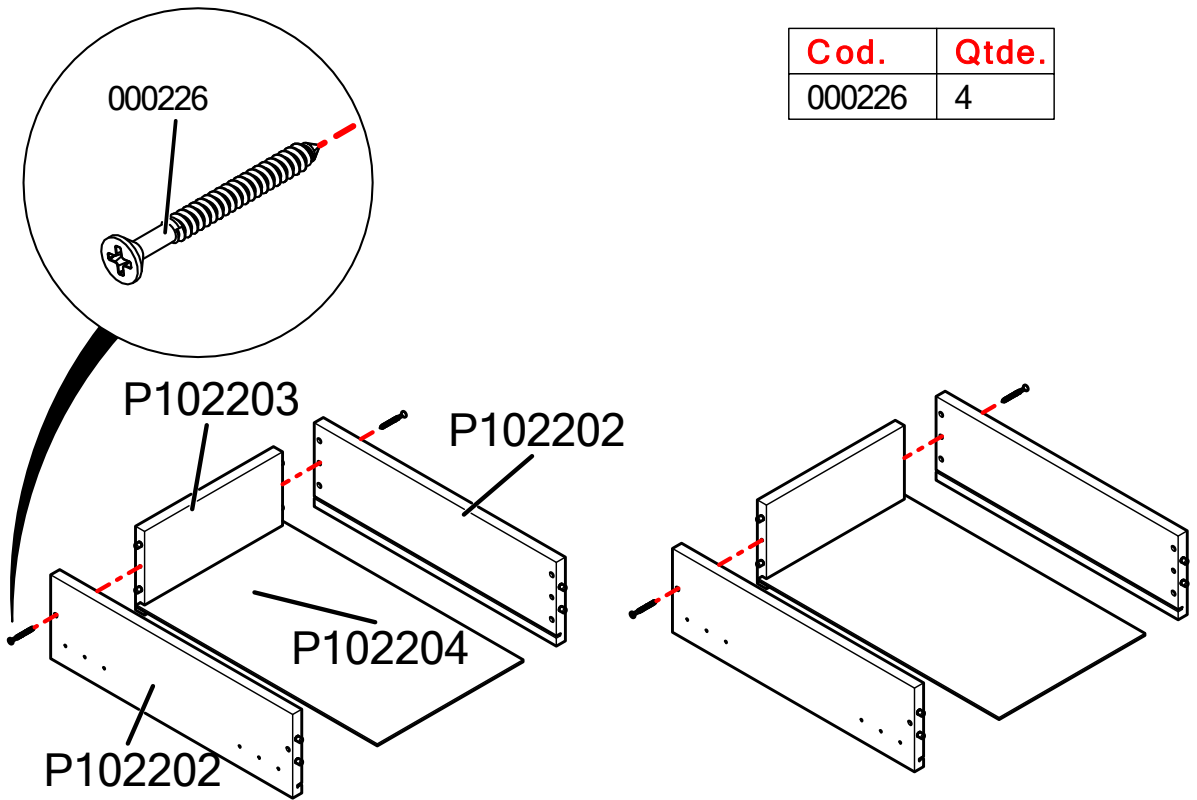

Cod.	Qtde.
000226	4

PASSO / PASO / STEP 4

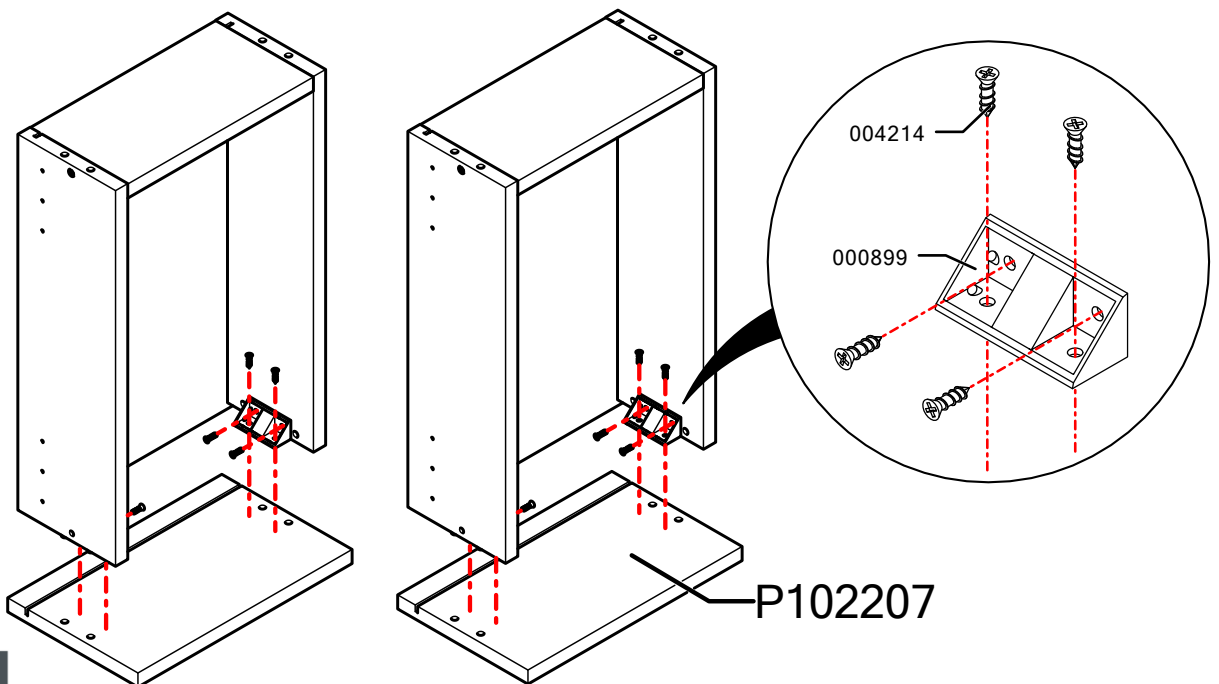

Cod.	Qtde.
000899	4
004214	16

PASSO / PASO / STEP 5

Cod.	Qtde.
005256	4
018458	4

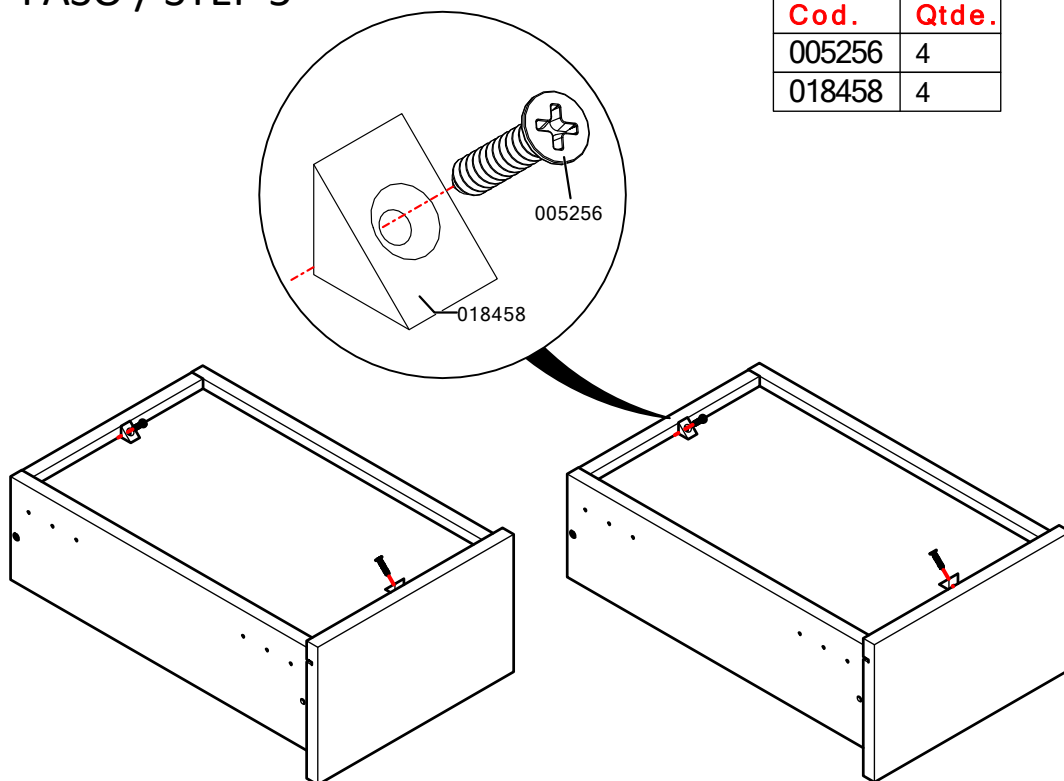

PASSO / PASO / STEP 6

Cod.	Qtde.
004214	12
038305	2

Atrás / Espalda / Back

Central / Centro / Center

Frente / Delantera / Front

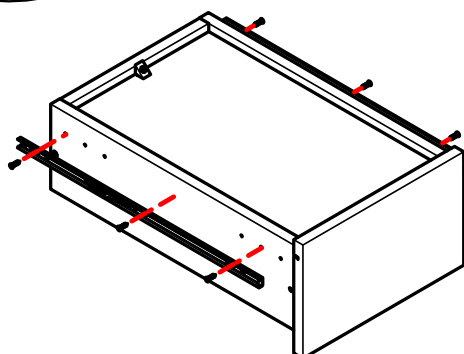
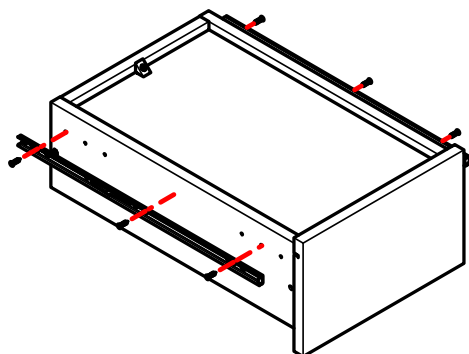
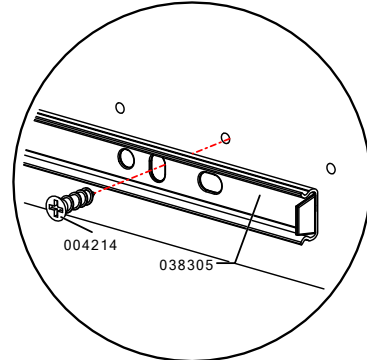
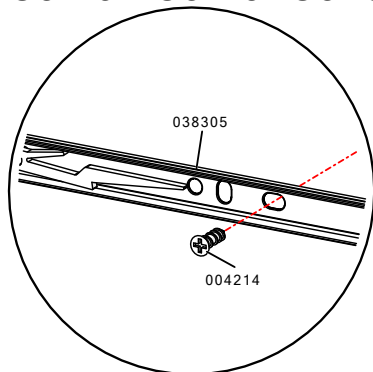
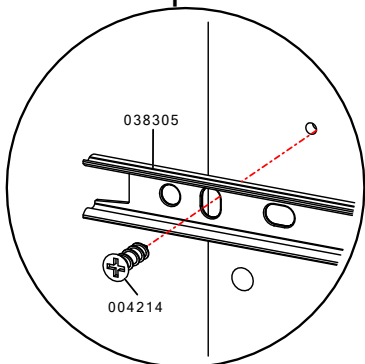

PASSO / PASO / STEP 7

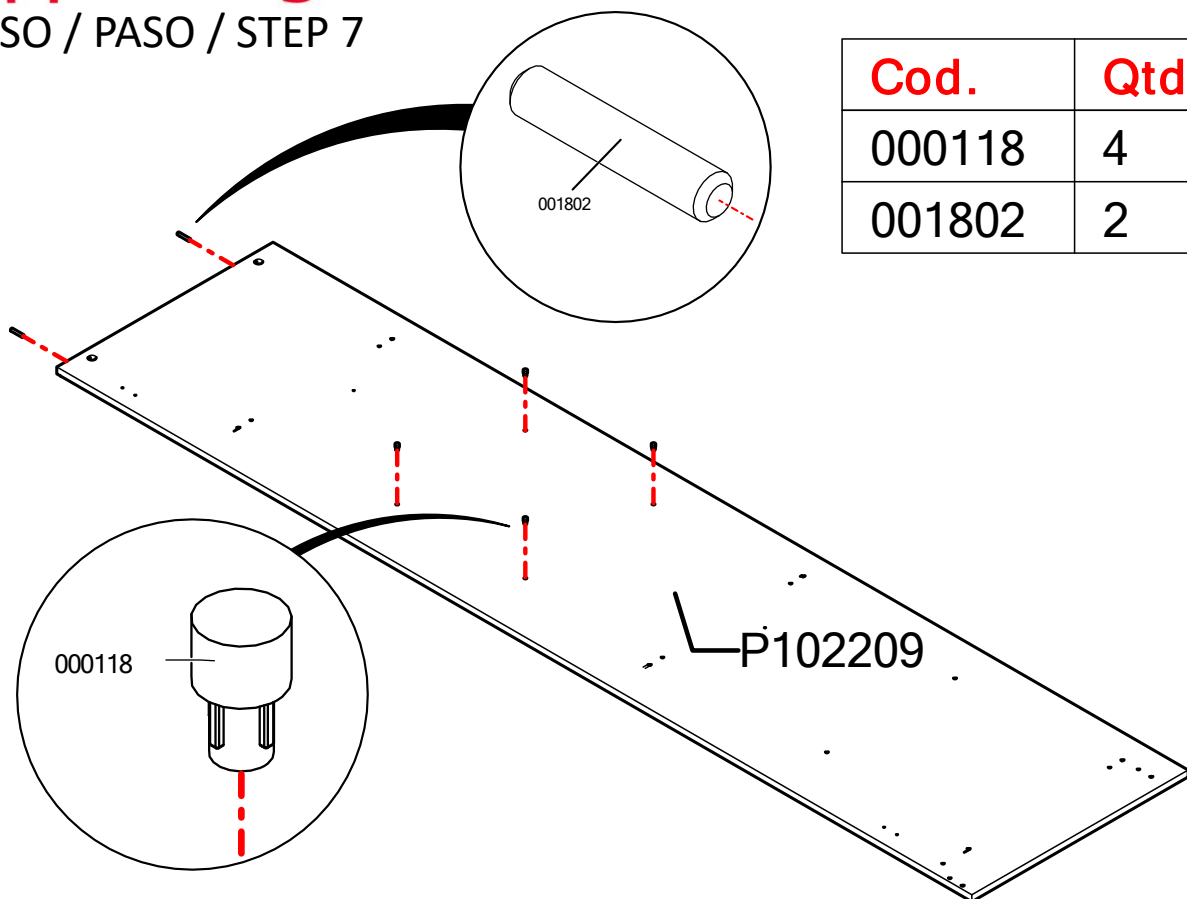

Cod.	Qtde.
000118	4
001802	2

PASSO / PASO / STEP 8

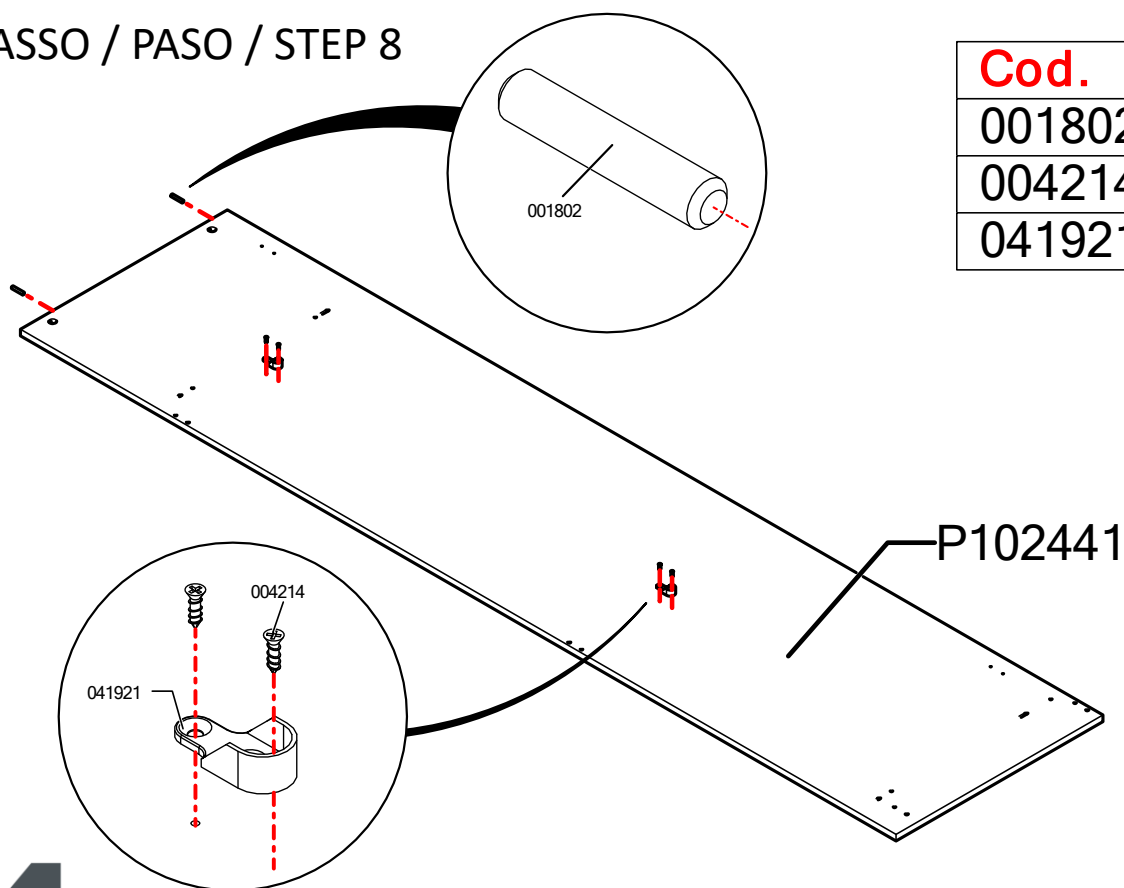

Cod.	Qtde.
001802	2
004214	4
041921	2

PASSO / PASO / STEP 9

Cod.	Qtde.
030945	6

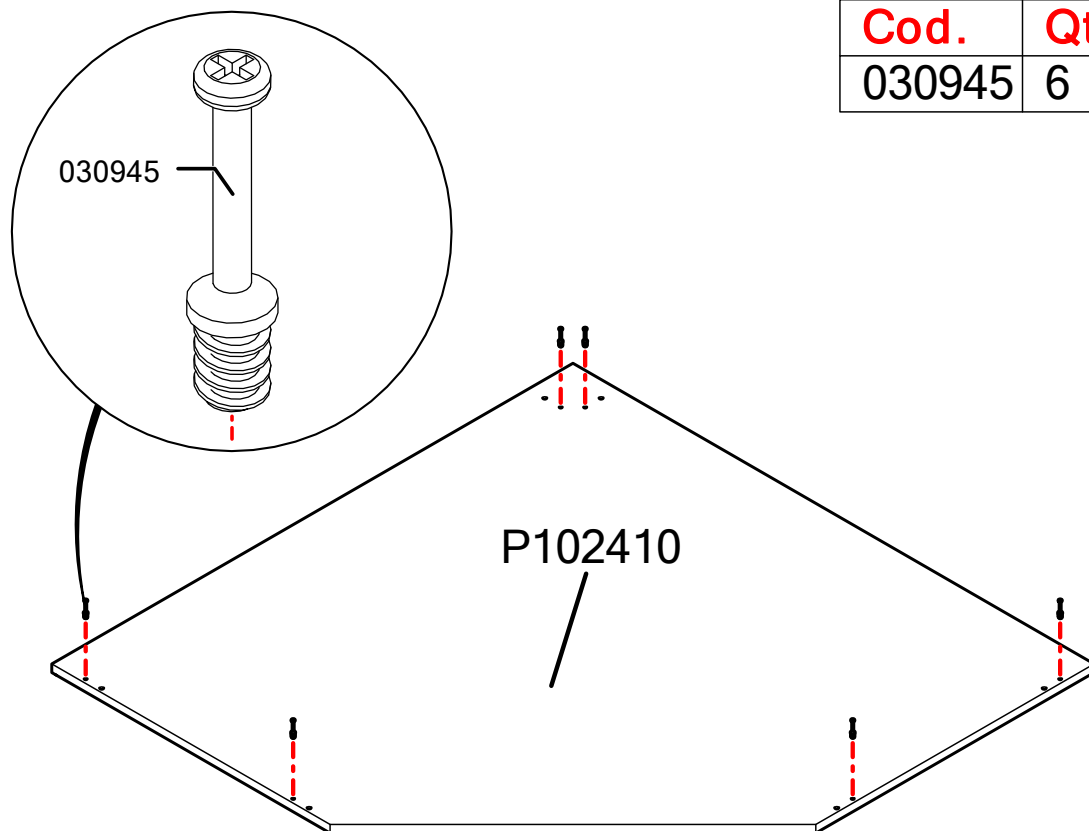

PASSO / PASO / STEP 10

Cod.	Qtde.
001802	2
001925	2

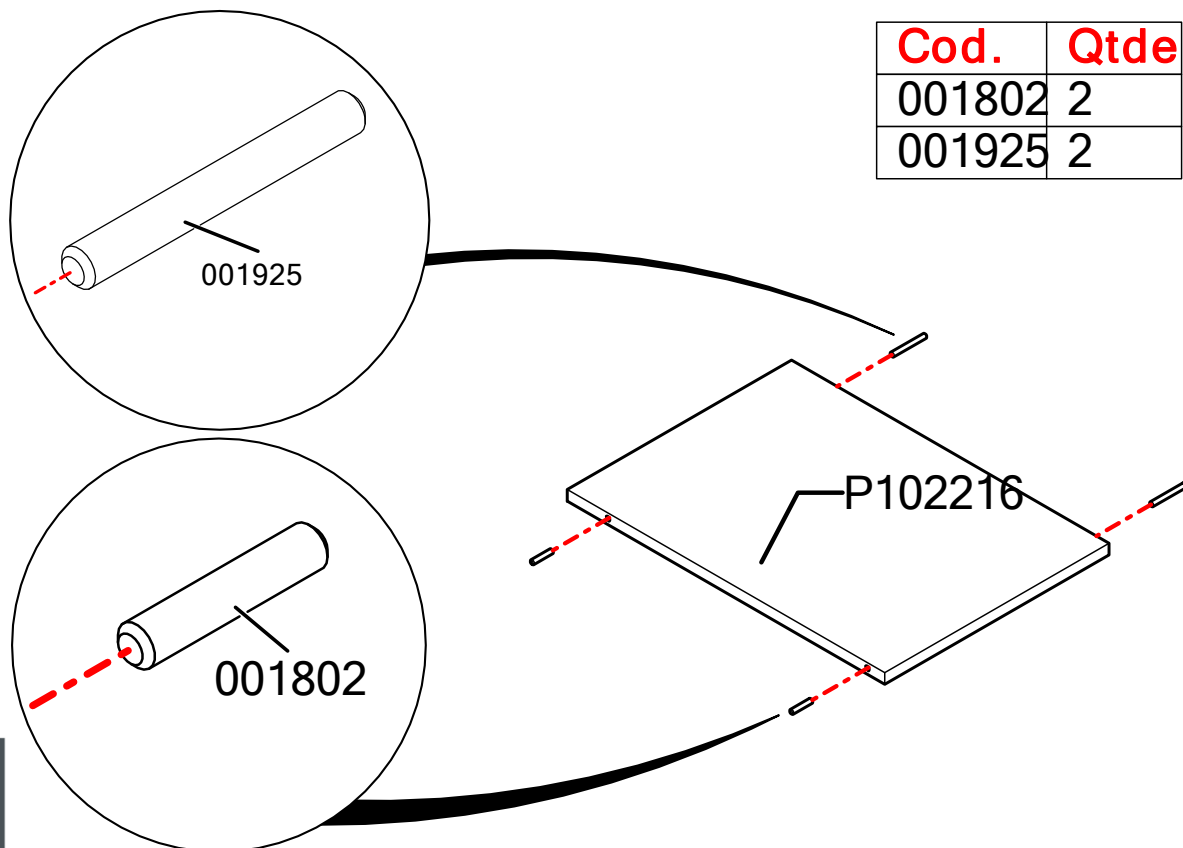

PASSO / PASO / STEP 11

Cod.	Qtde.
001802	2

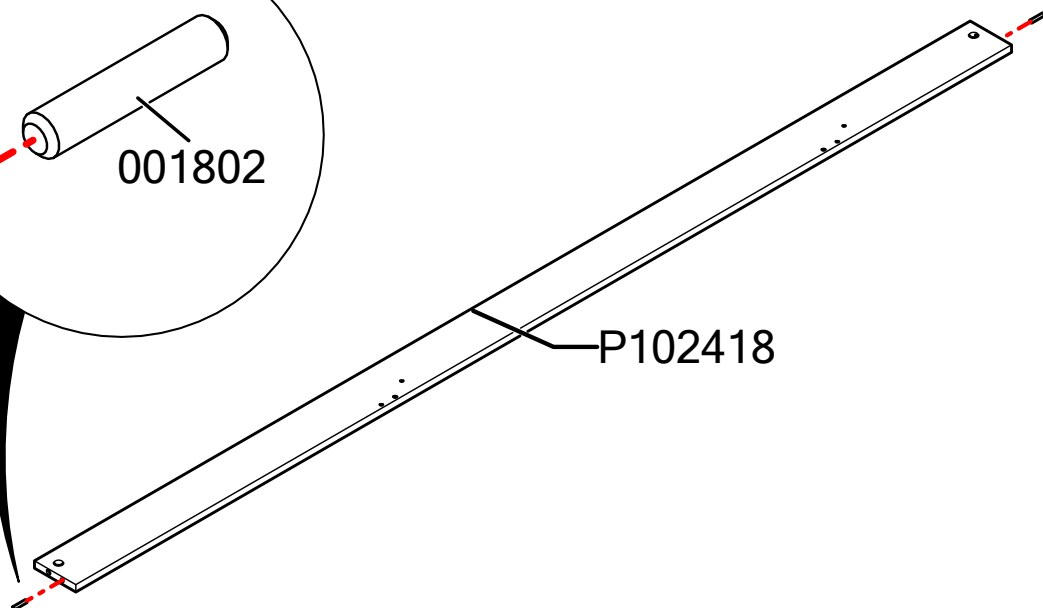
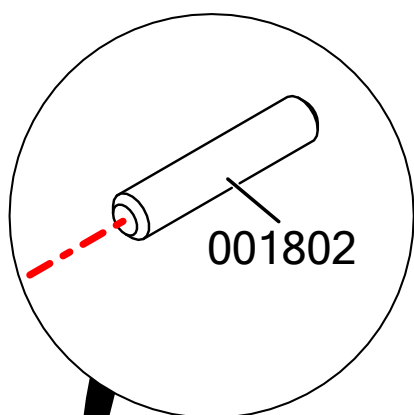

PASSO / PASO / STEP 12

Cod.	Qtde.
001802	2

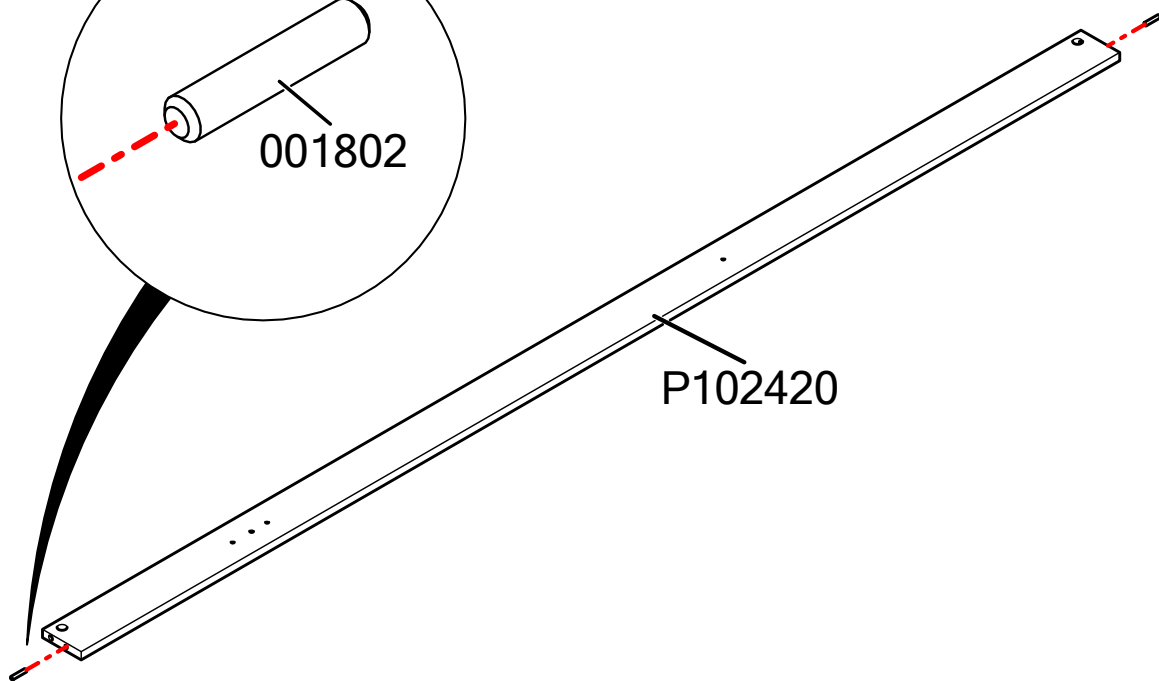
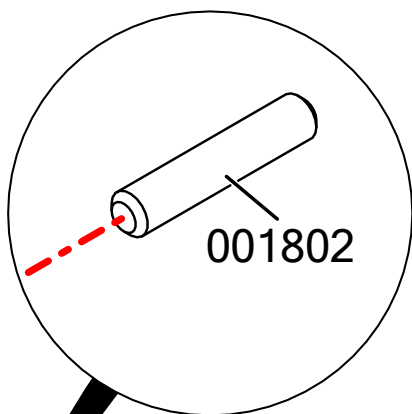

PASSO / PASO / STEP 13

Cod.	Qtde.
001802	2

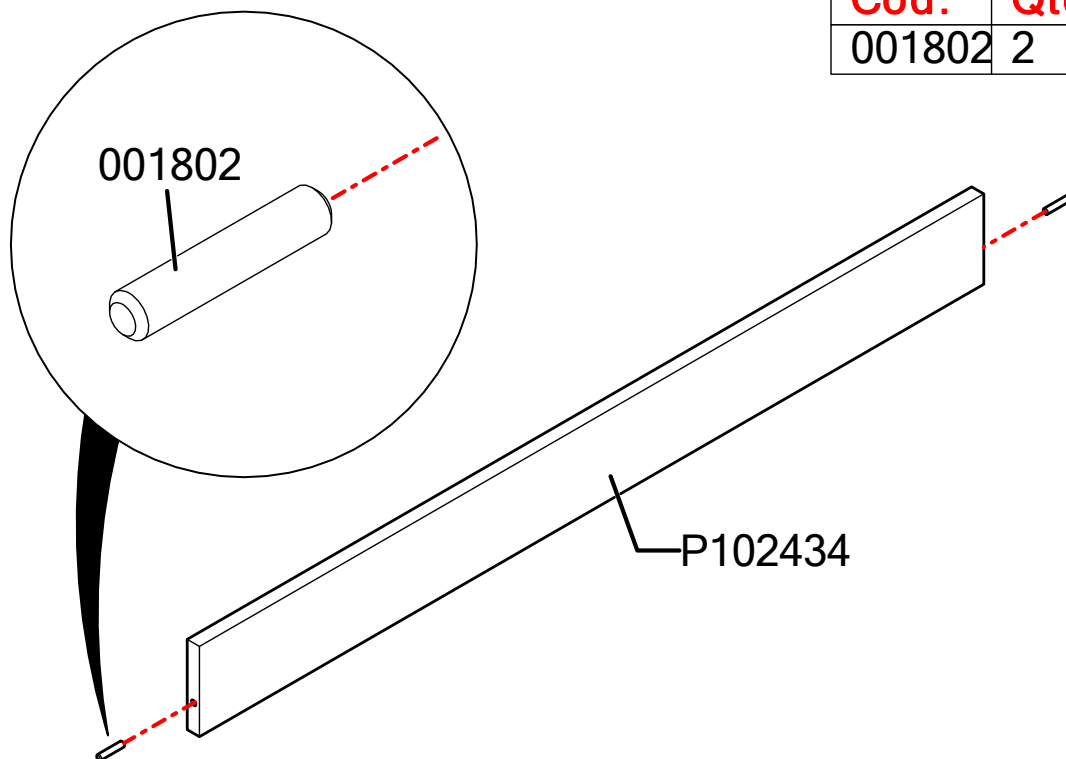

PASSO / PASO / STEP 14

Cod.	Qtde.
001802	1

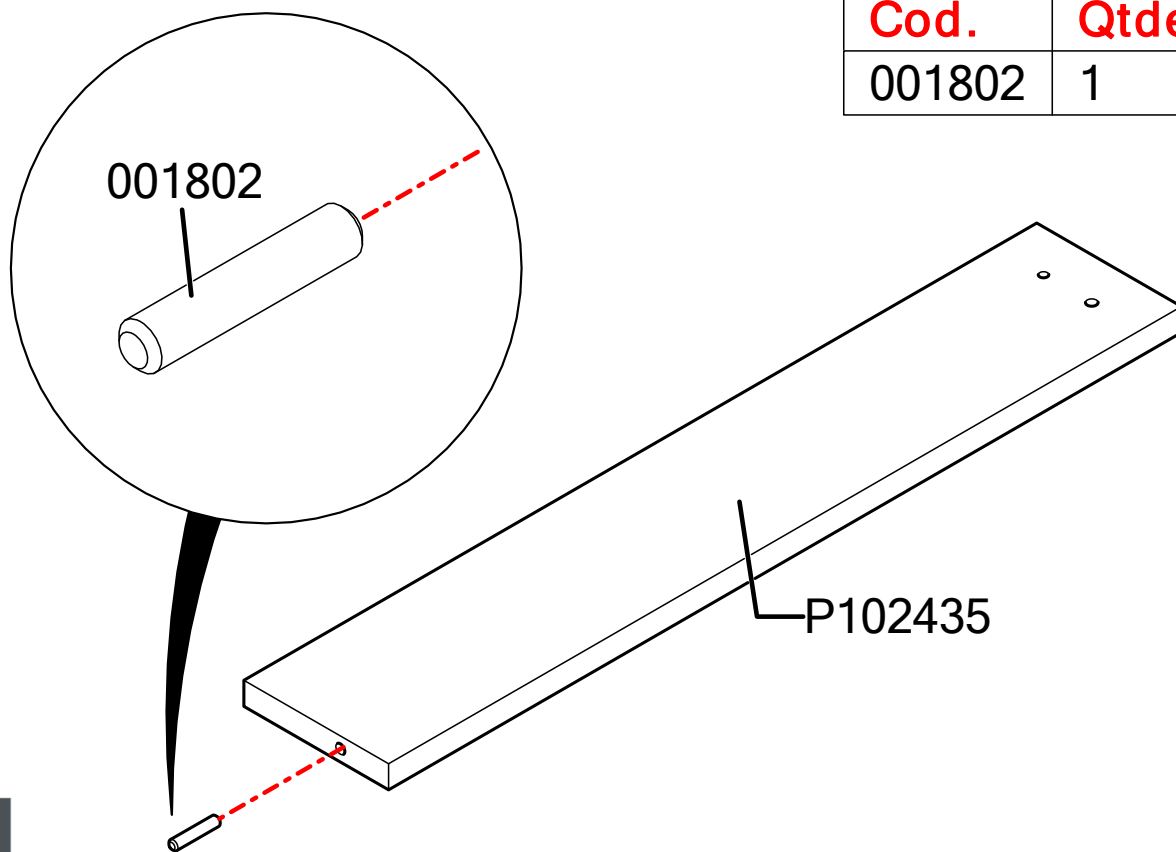

PASSO / PASO / STEP 15

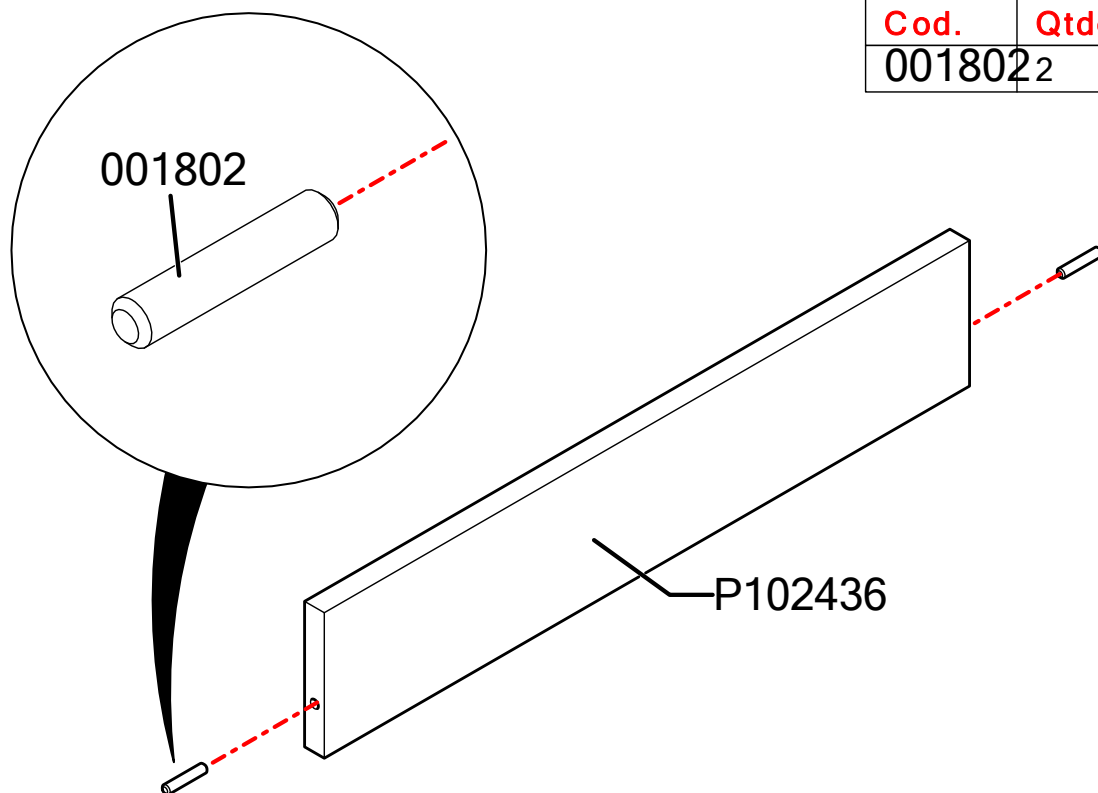

Cod.	Qtde.
001802	2

PASSO / PASO / STEP 16

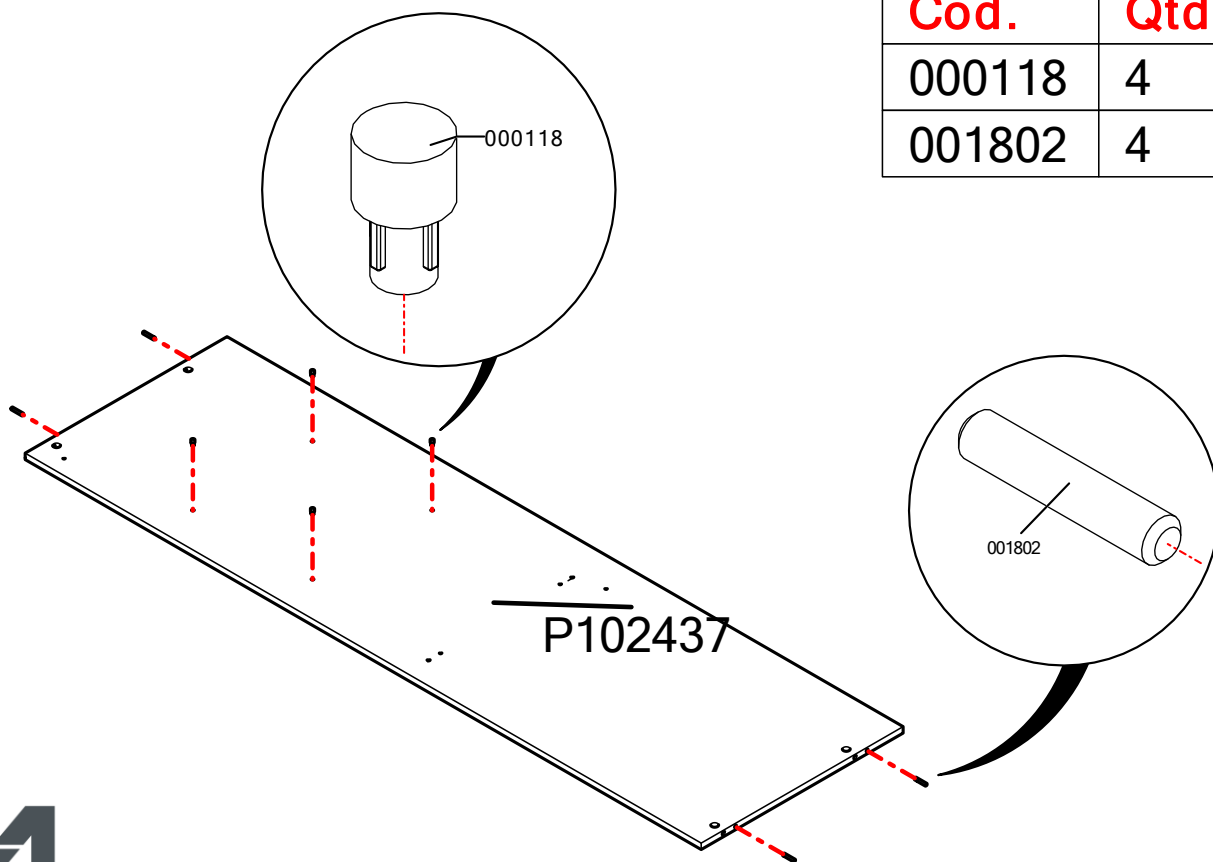

Cod.	Qtde.
000118	4
001802	4

PASSO / PASO / STEP 17

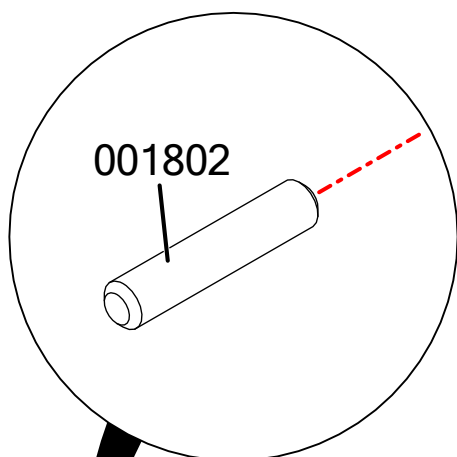

Cod.	Qtde.
001802	2

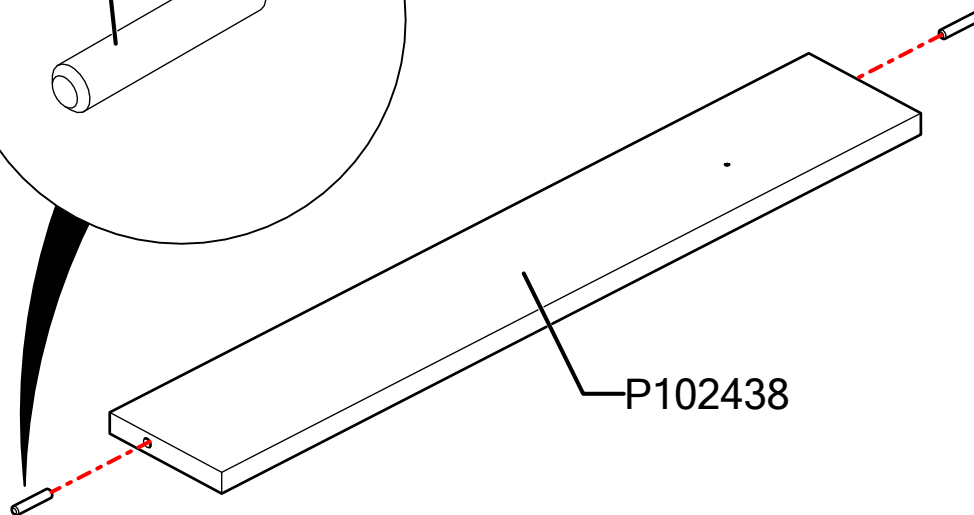

PASSO / PASO / STEP 18

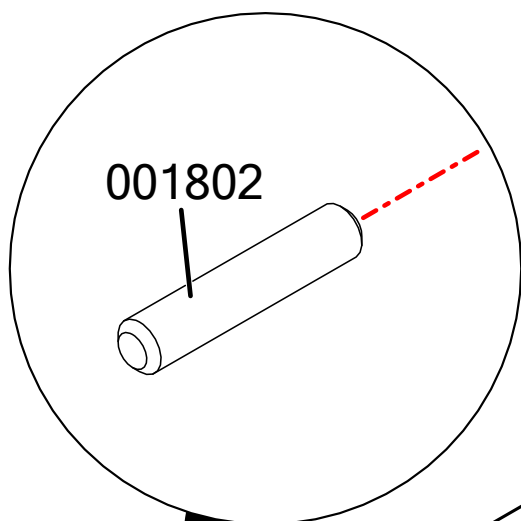

Cod.	Qtde.
001802	2

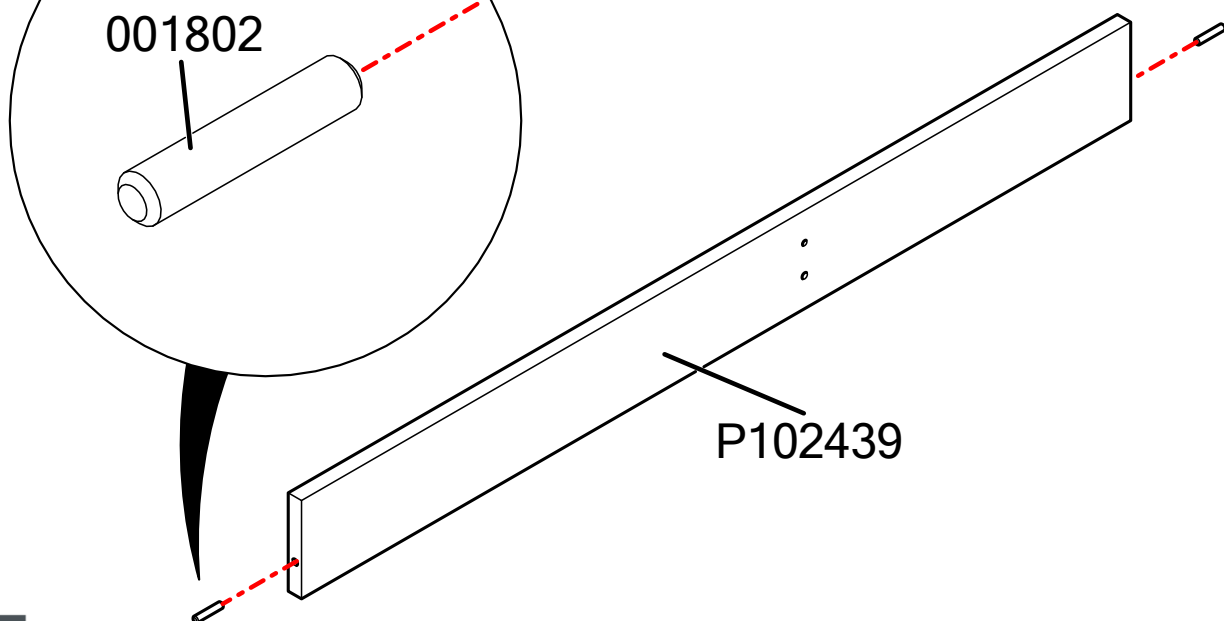

PASSO / PASO / STEP 19

Cod.	Qtde.
001802	2
004214	2
041921	1

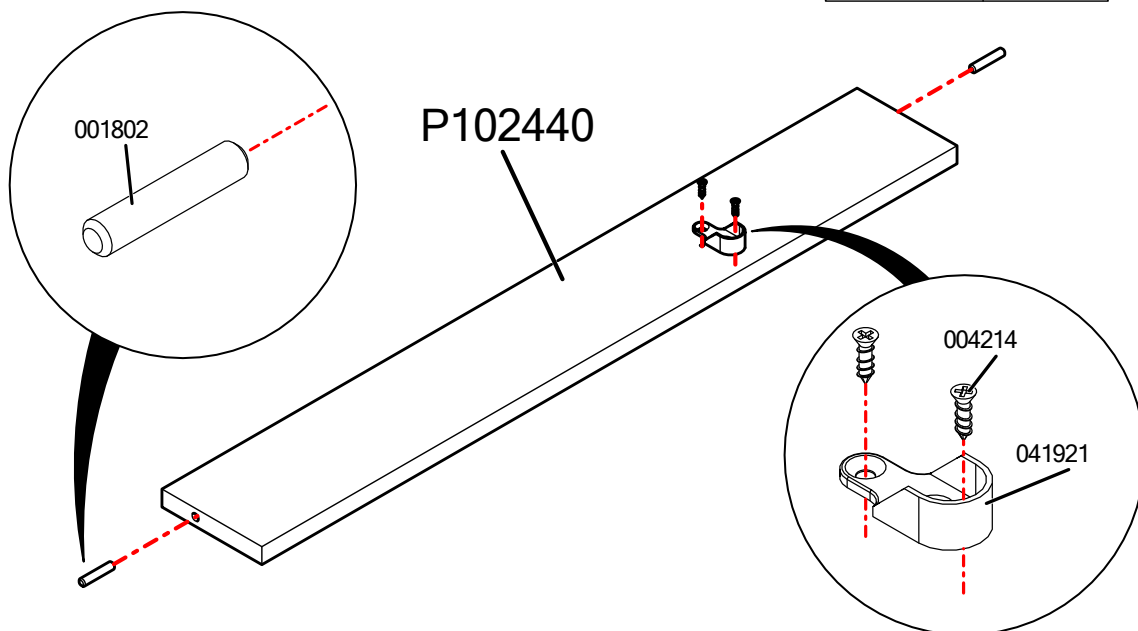

PASSO / PASO / STEP 20

Cod.	Qtde.
001802	4
030945	2

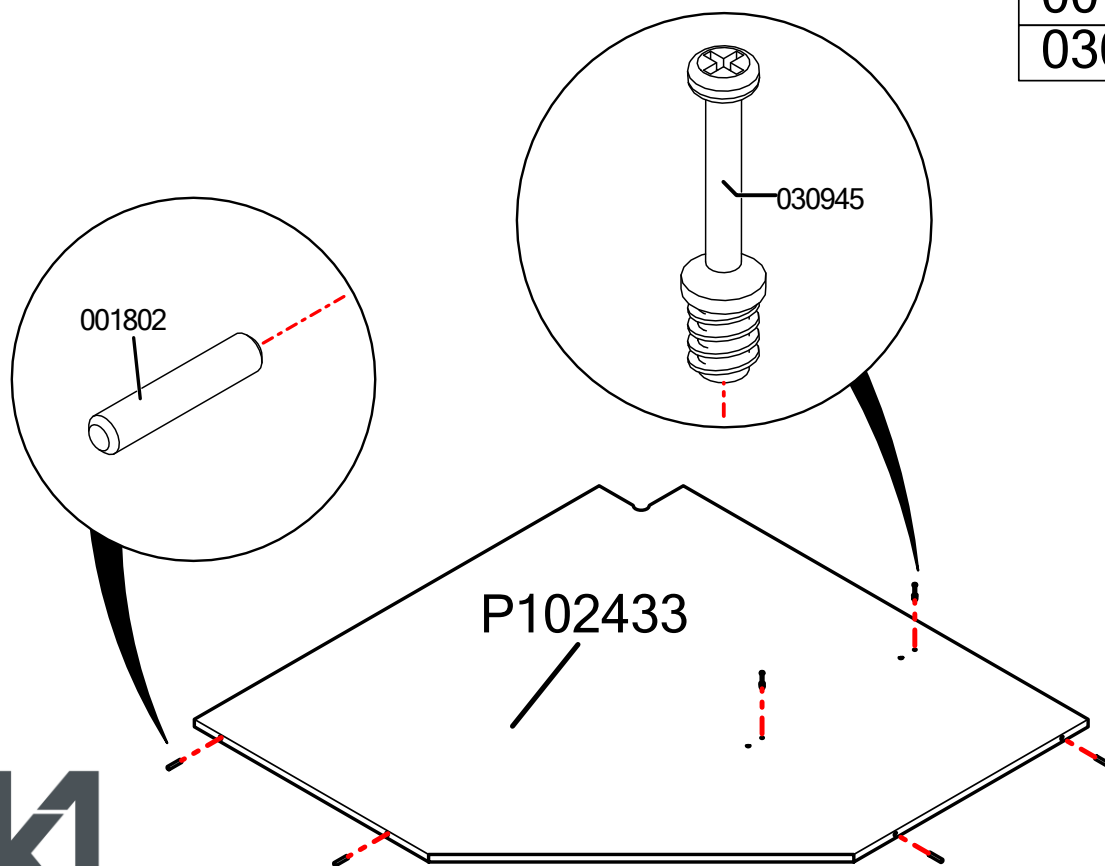

PASSO / PASO / STEP 21

Cod.	Qtde.
001802	4

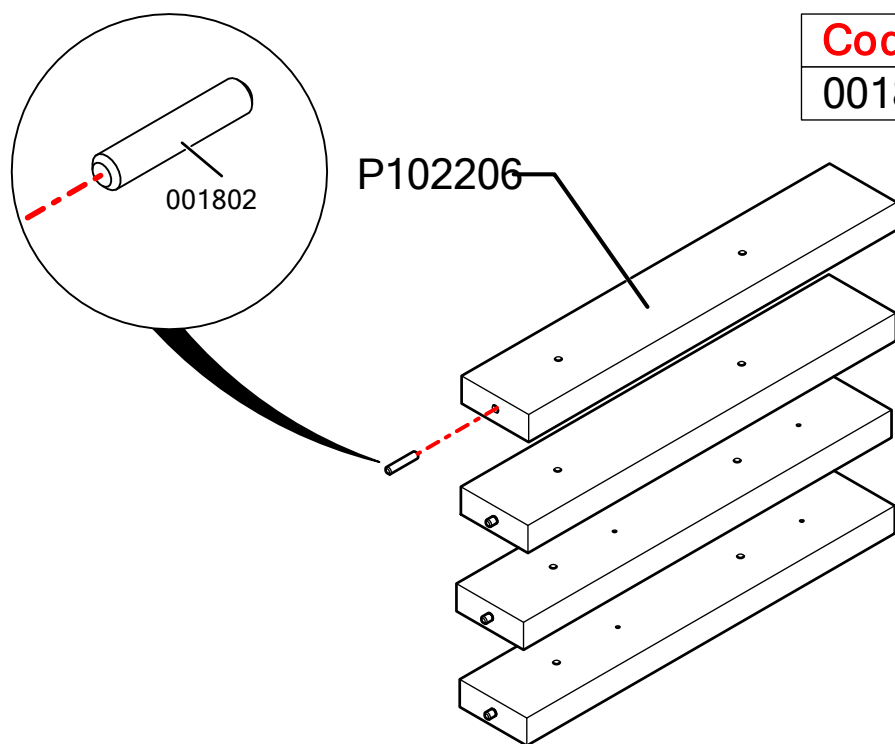

PASSO / PASO / STEP 22

Cod.	Qtde.
001802	4
030945	4

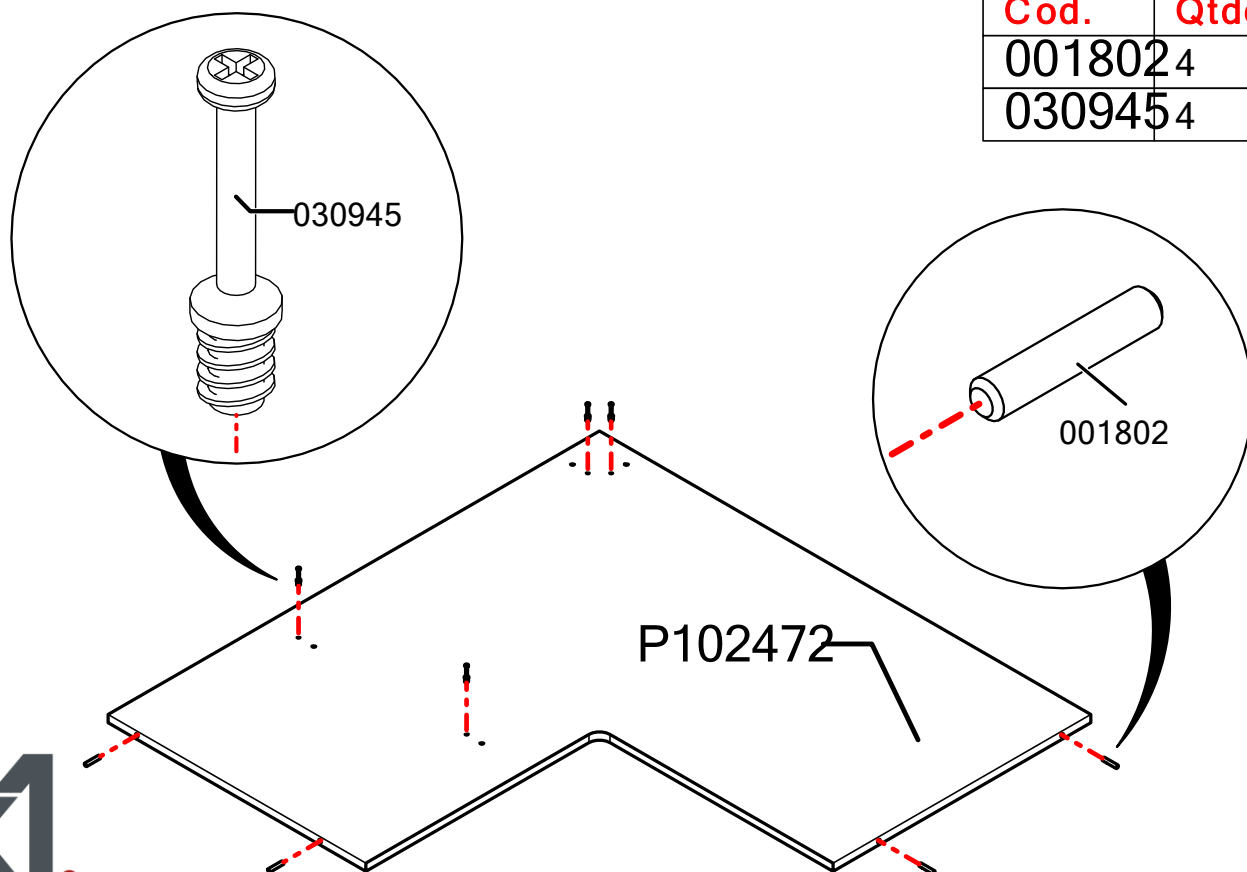

PASSO / PASO / STEP 23

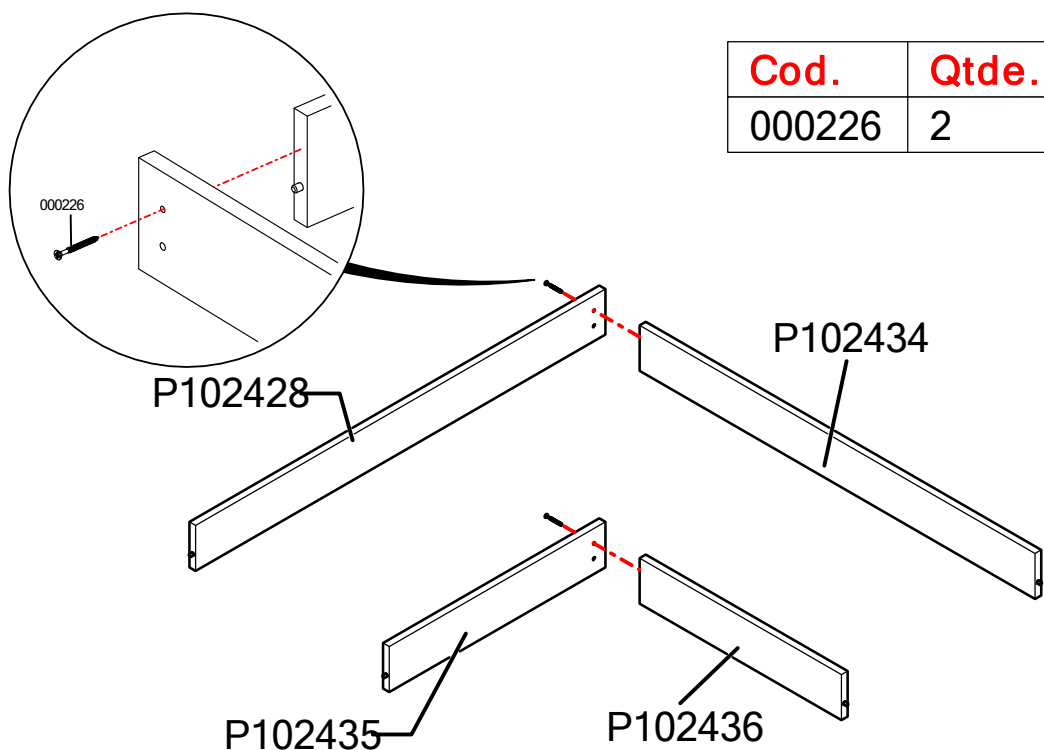

PASSO / PASO / STEP 24

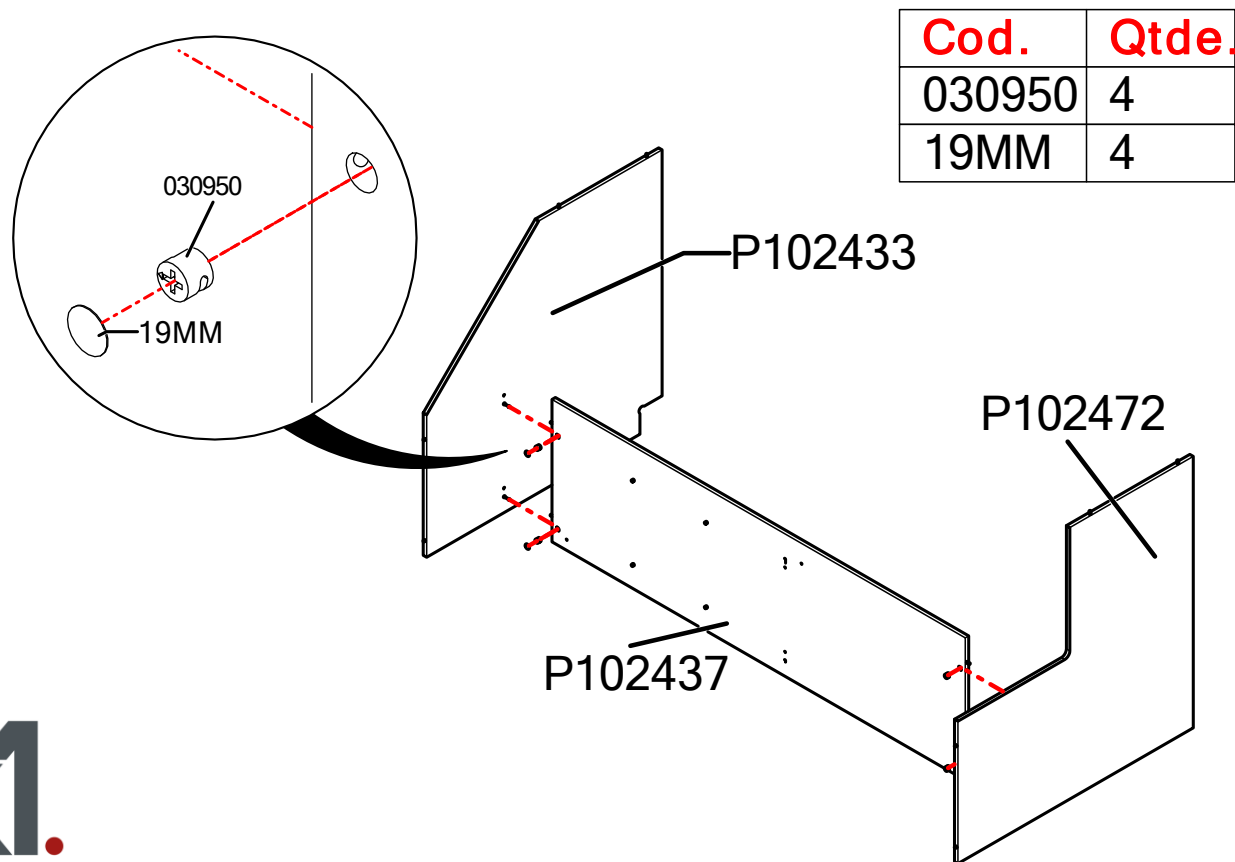

PASSO / PASO / STEP 25

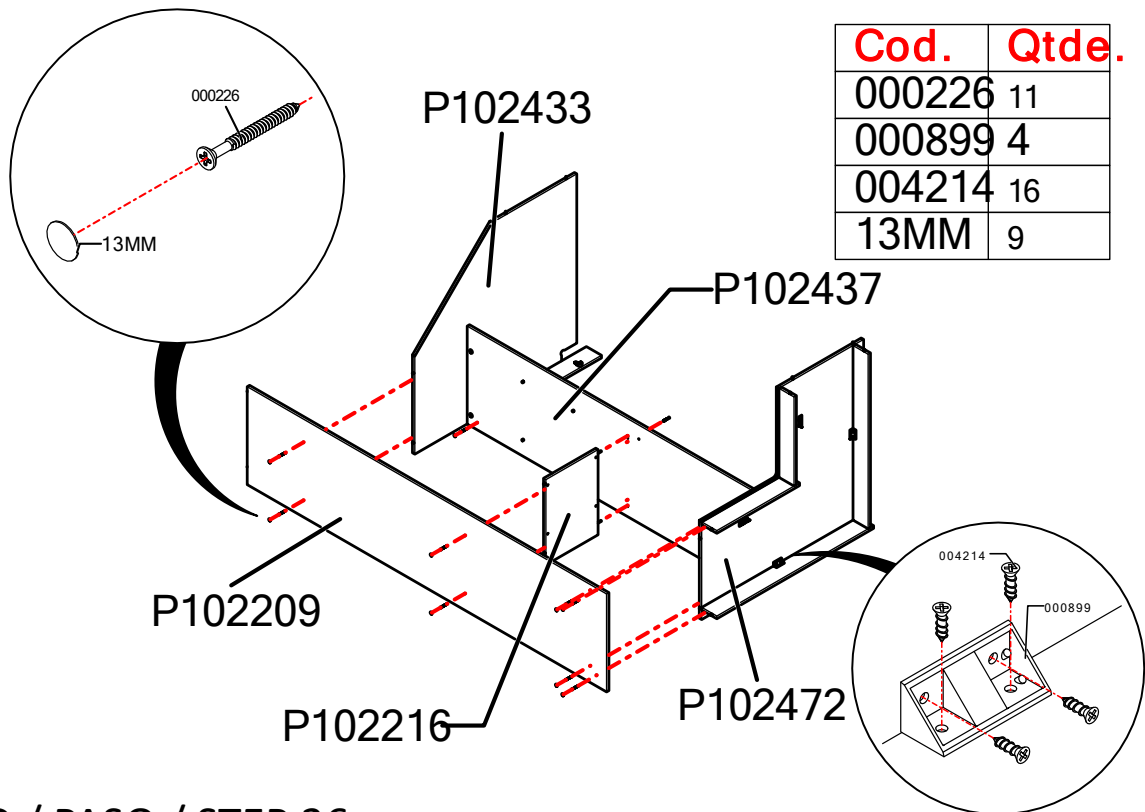

Cod.	Qtde.
000226	11
000899	4
004214	16
13MM	9

PASSO / PASO / STEP 26

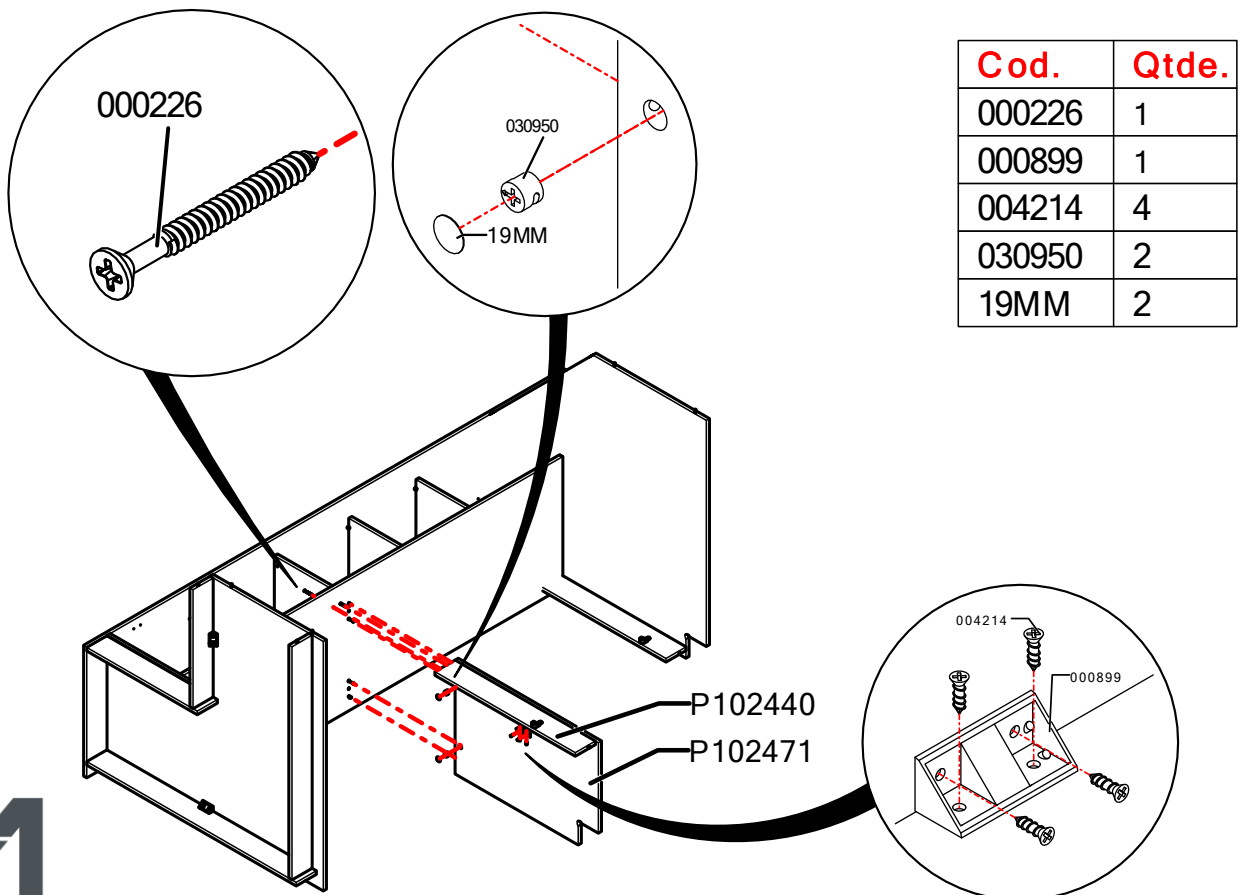

Cod.	Qtde.
000226	1
000899	1
004214	4
030950	2
19MM	2

PASSO / PASO / STEP 27

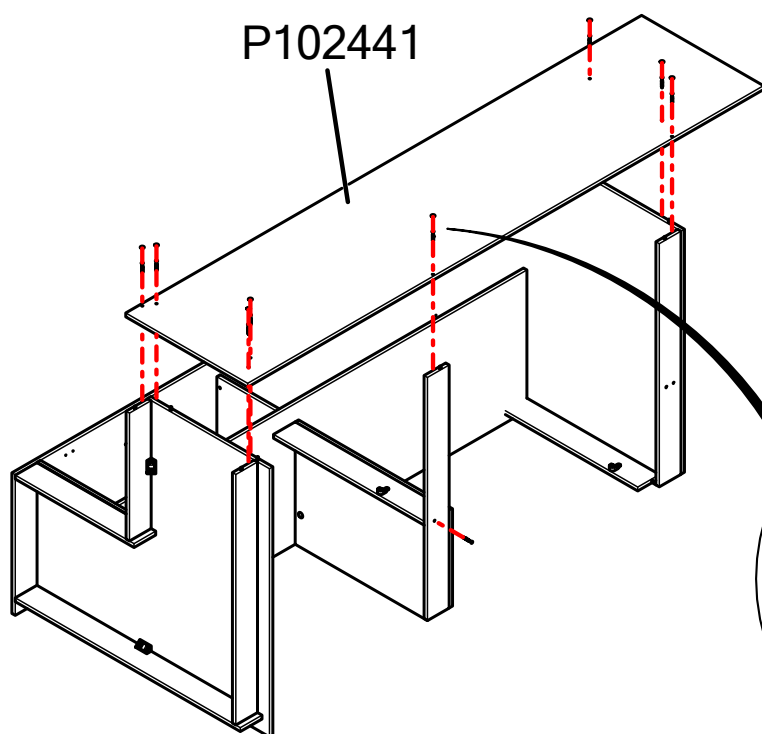

Cod.	Qtde.
000226	9
13MM	8

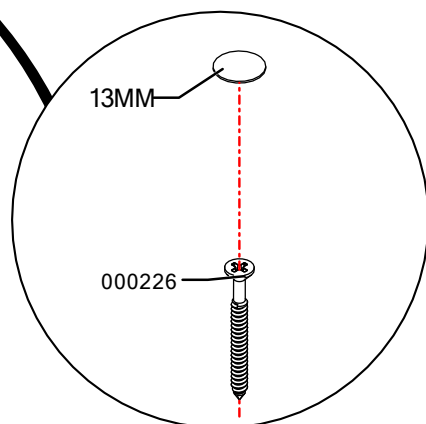

PASSO / PASO / STEP 28

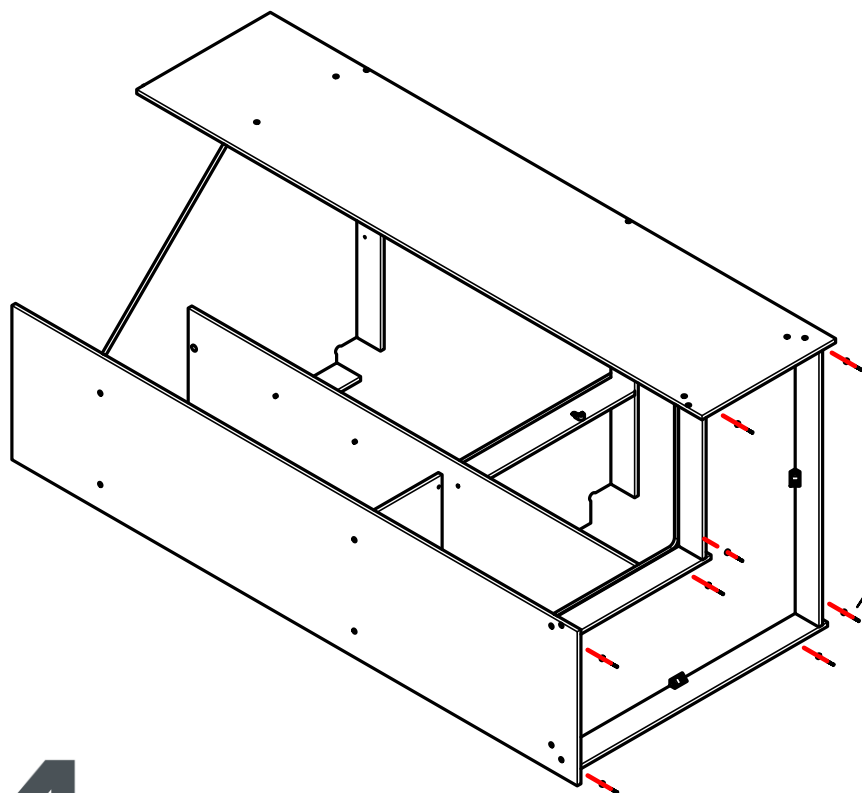

Cod.	Qtde.
000108	8
001901	8

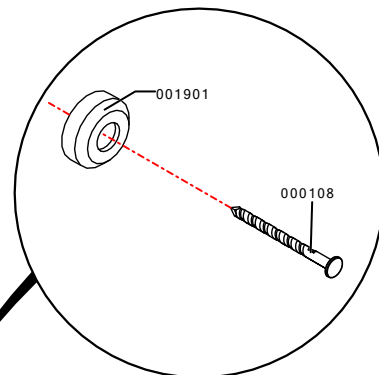

PASSO / PASO / STEP 29

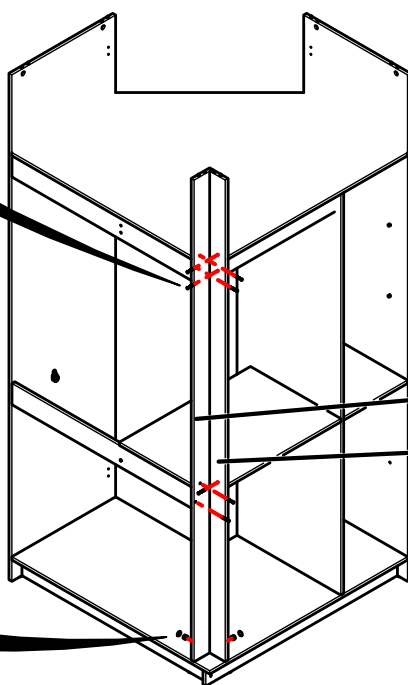
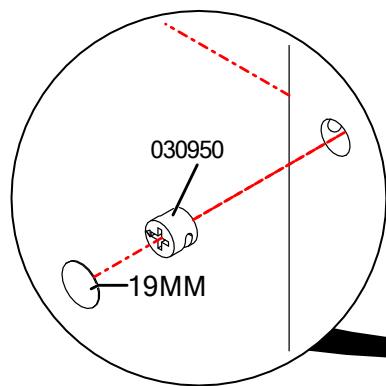
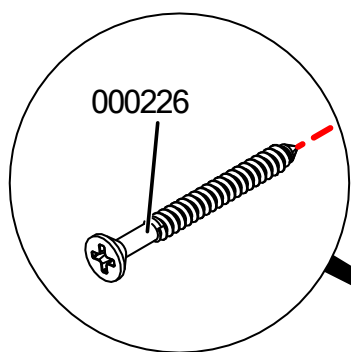

Cod.	Qtde.
000226	7
030950	2
19MM	2

P102418
P102420

PASSO / PASO / STEP 30

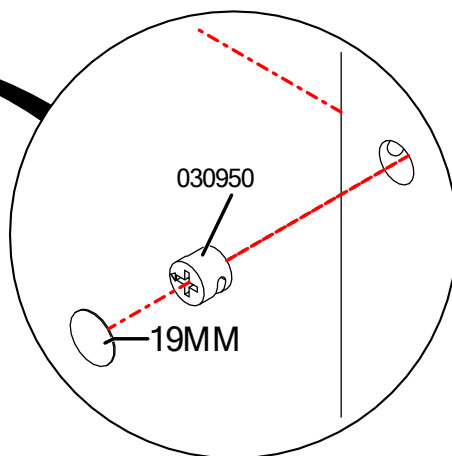
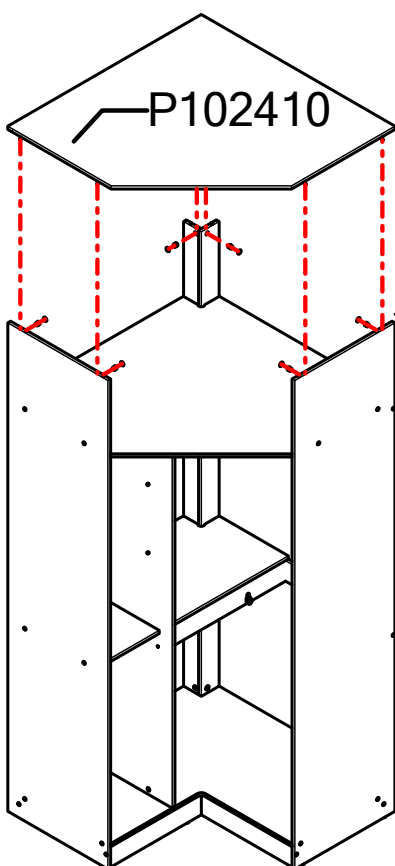

Cod.	Qtde.
030950	6
19MM	6

PASSO / PASO / STEP 31

Cod.	Qtde.
004214	8
038305	2

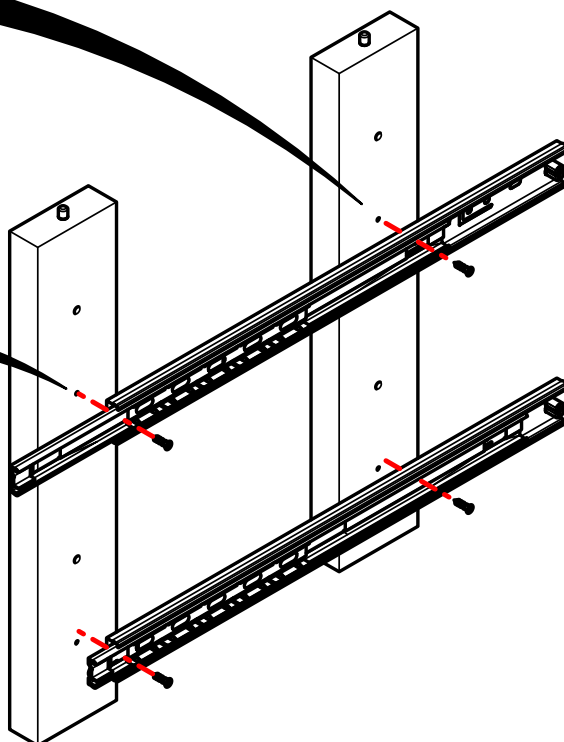
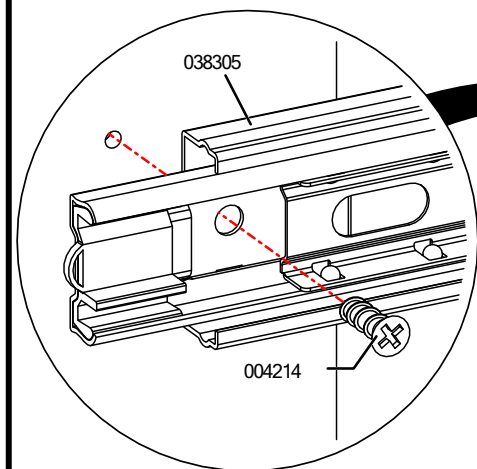
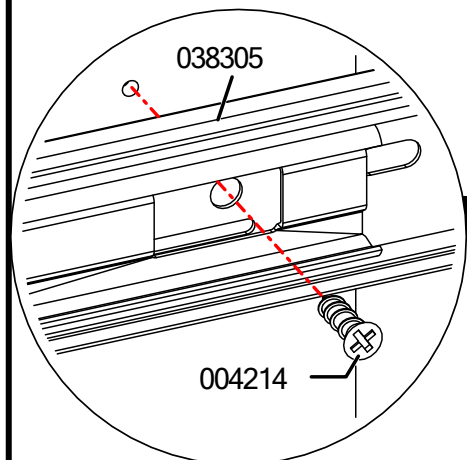

PASSO / PASO / STEP 31

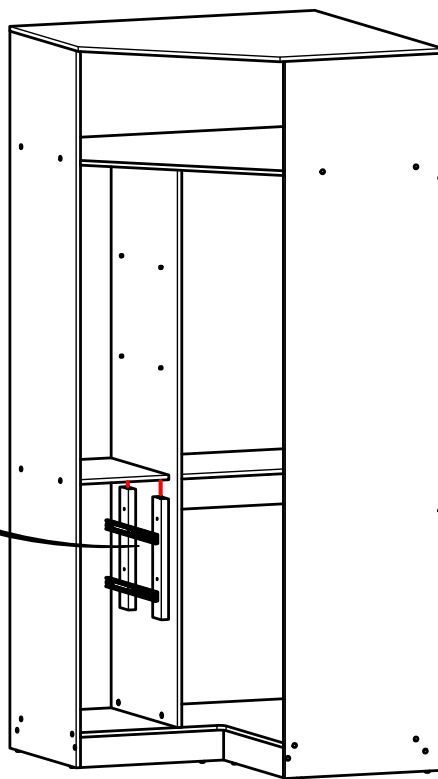
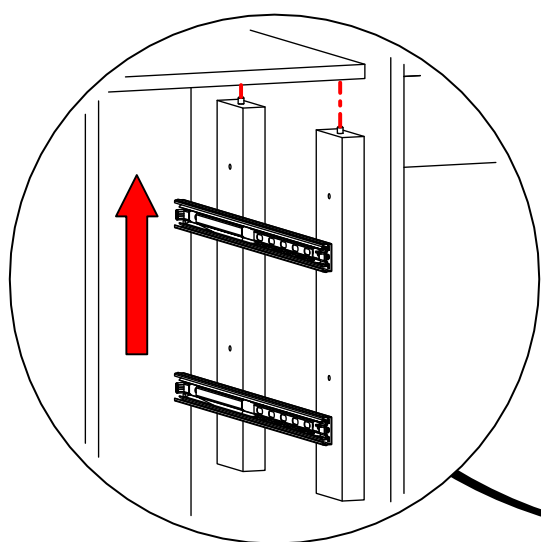

PASSO / PASO / STEP 32

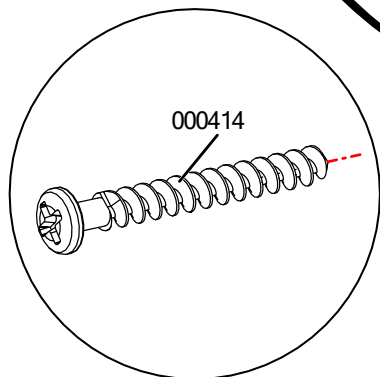
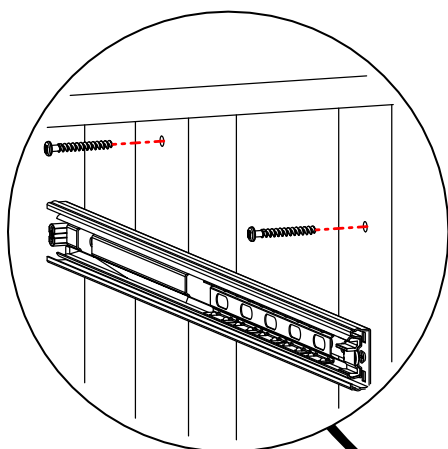

Cod.	Qtde.
000414	8

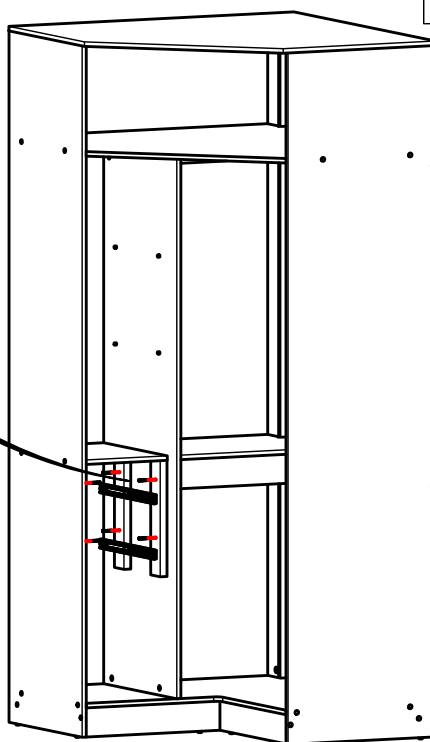

PASSO / PASO / STEP 33

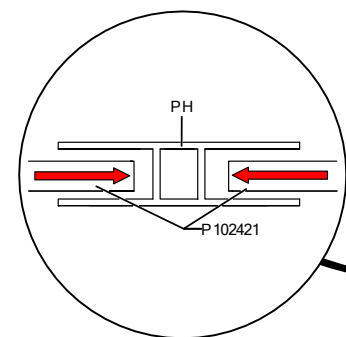

Cod.	Qtde.
000107	168
PH	2

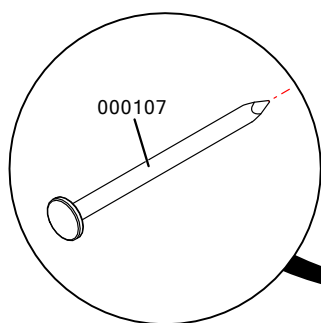

P102421

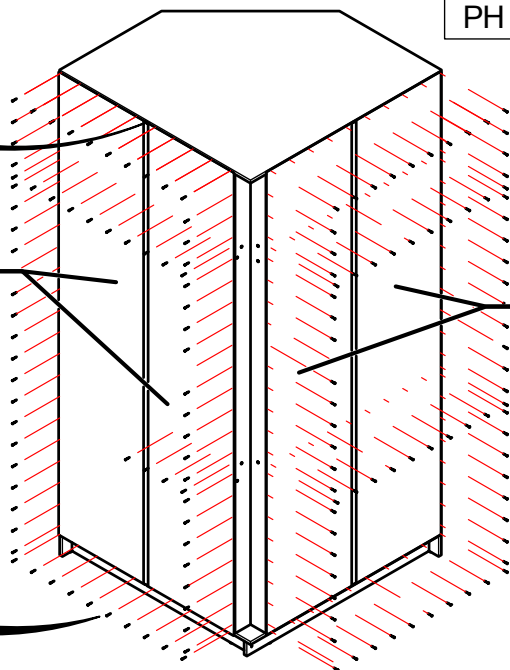

P102421

PASSO / PASO / STEP 34

P102213

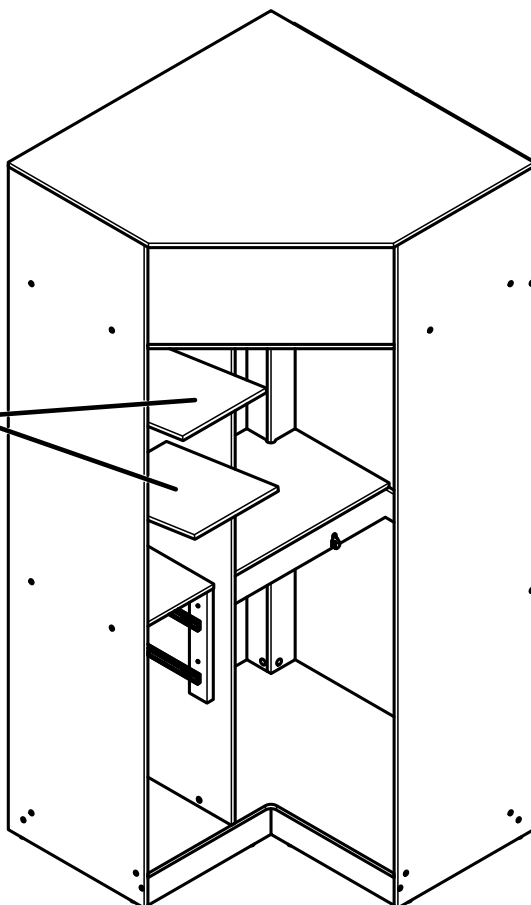

PASSO / PASO / STEP 35

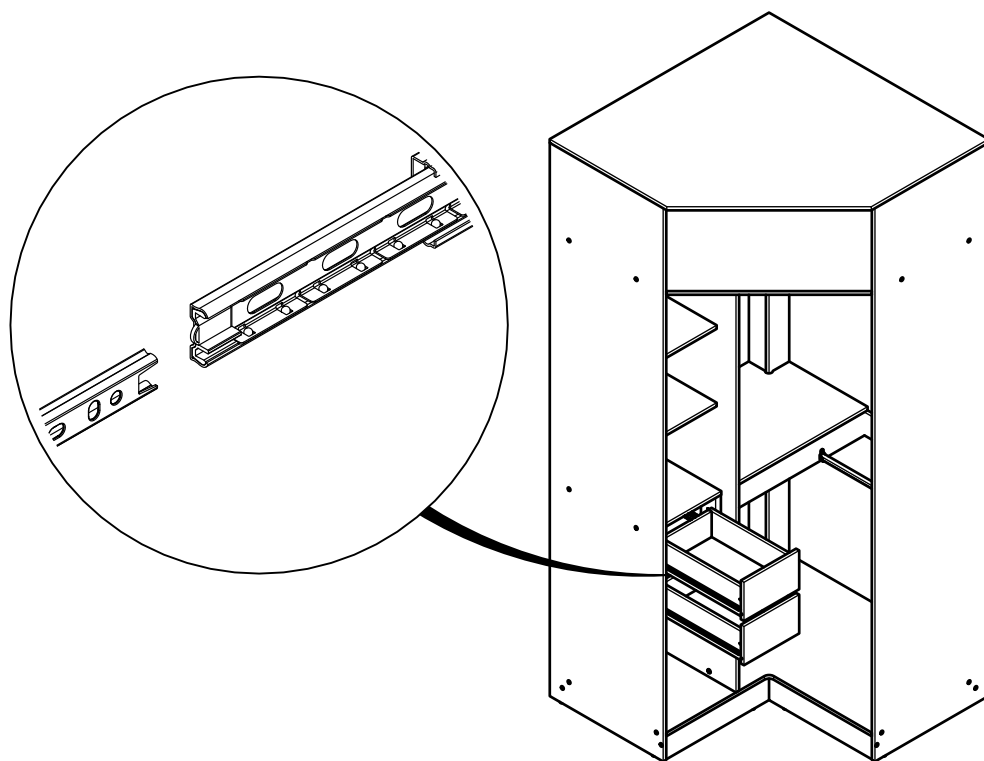

PASSO / PASO / STEP 36

Cod.	Qtde.
054117	4

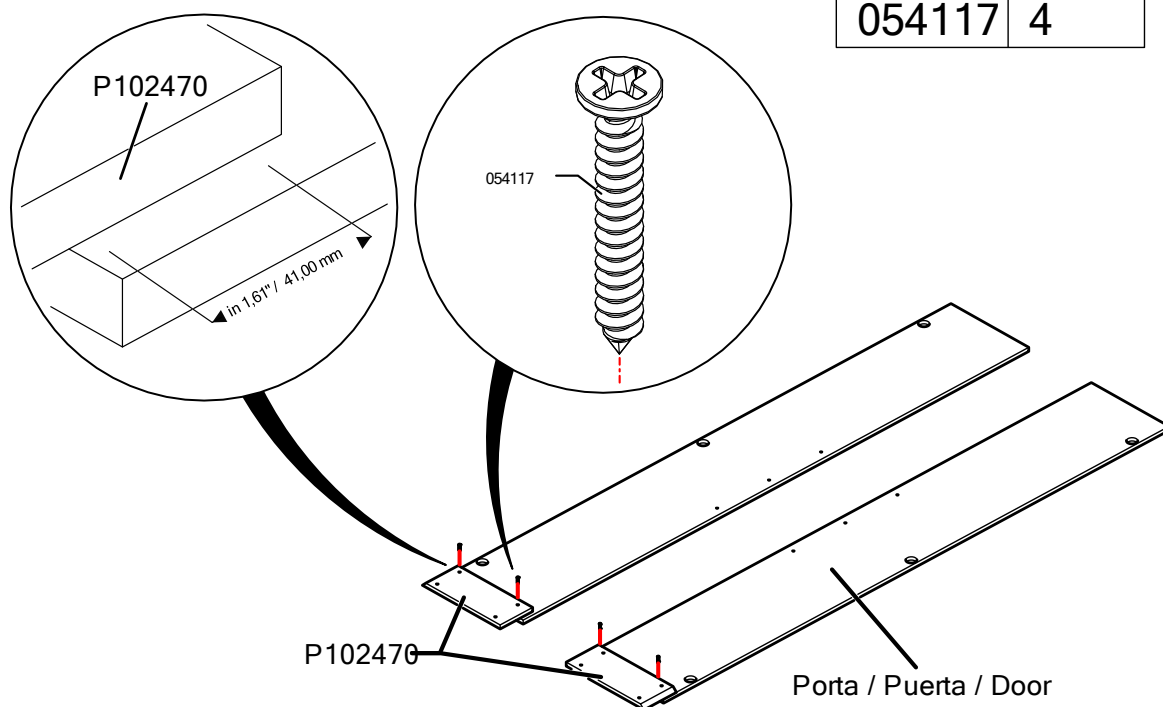

PASSO / PASO / STEP 37

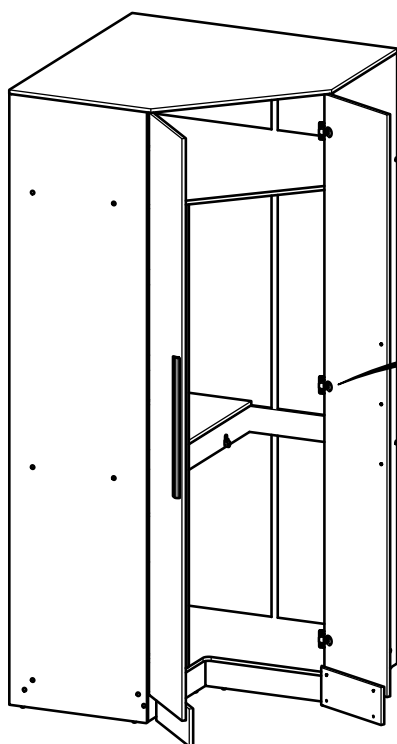

Cod.	Qtde.
015021	6
061971	24

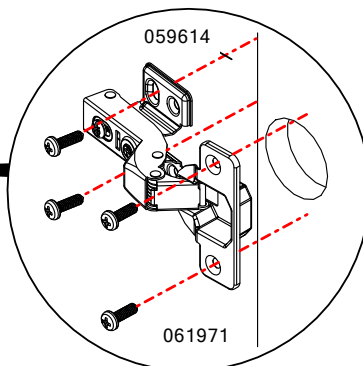

PASSO / PASO / STEP 38

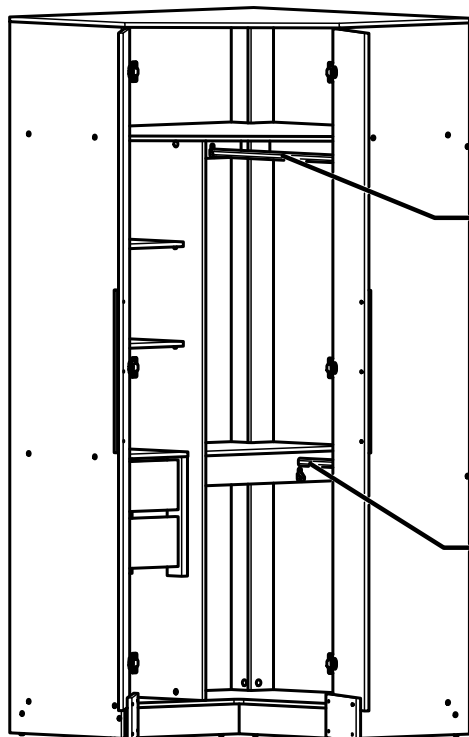

Cod.	Qtde.
076864	1
076865	1

076864

076865

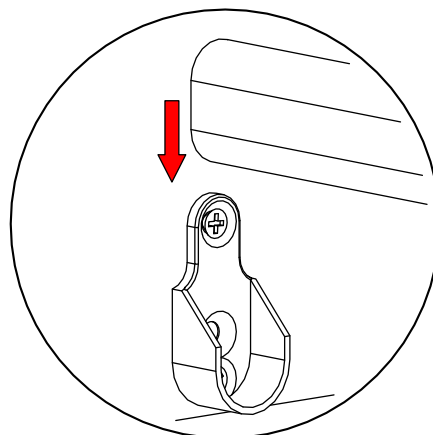

Manual de montagem

Instrucciones de montaje Assembly instructions

PA2AMDP342

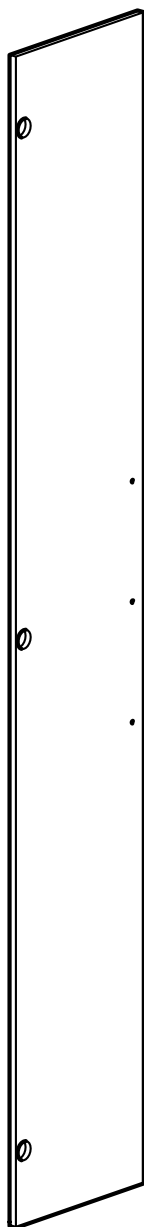

! Imagens meramente ilustrativas !
Imágenes ilustrativas/Images merely illustrative.

Dúvidas? Entre em contato:
Dudas? Ponerse em contacto:
Doubts? Get in touch:
(51) 3635-8839

A montagem deve ser efetuada por 2 pessoas.

El montaje debe ser efectuada por 2 personas.

The assembly must be done by 2 people.

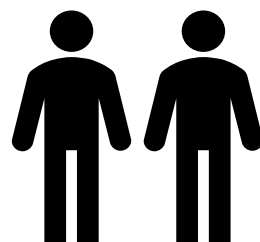

Ferramentas necessárias para montar o móvel.

Herramientas necesarias para armar el mueble
Tools needed to assemble the furniture.



Dúvidas? Entrar em contato:

Dudas? Ponerse en contacto:

Doubts? Get in touch:

Fone: (51) 3635-8839

www.kappesberg.com.br



Montar o móvel sobre uma superfície limpa e plana.

Armar el mueble sobre una superficie limpia y plana.

Assemble the furniture on a clean, flat surface.

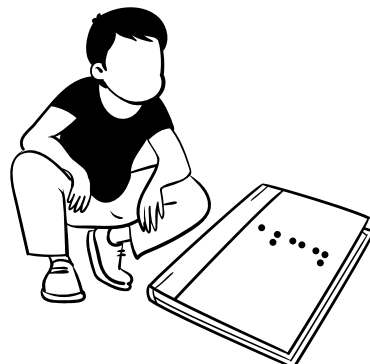

**IDENTIFICAÇÃO DAS PEÇAS / IDENTIFICACIÓN DE LAS PIEZAS PARTS
IDENTIFICATION**

Quantidade Cantidad Amount	Código Code	Descrição	Descripción	Description	C x L x E	L x W x T
2	P102486	PORTA	PUERTA	DOOR	2177 x 342 x 15 mm	85.71 x 13.46 x 0.59 in

IDENTIFICAÇÃO DAS PEÇAS / IDENTIFICACIÓN DE LAS PIEZAS PARTS
IDENTIFICATION

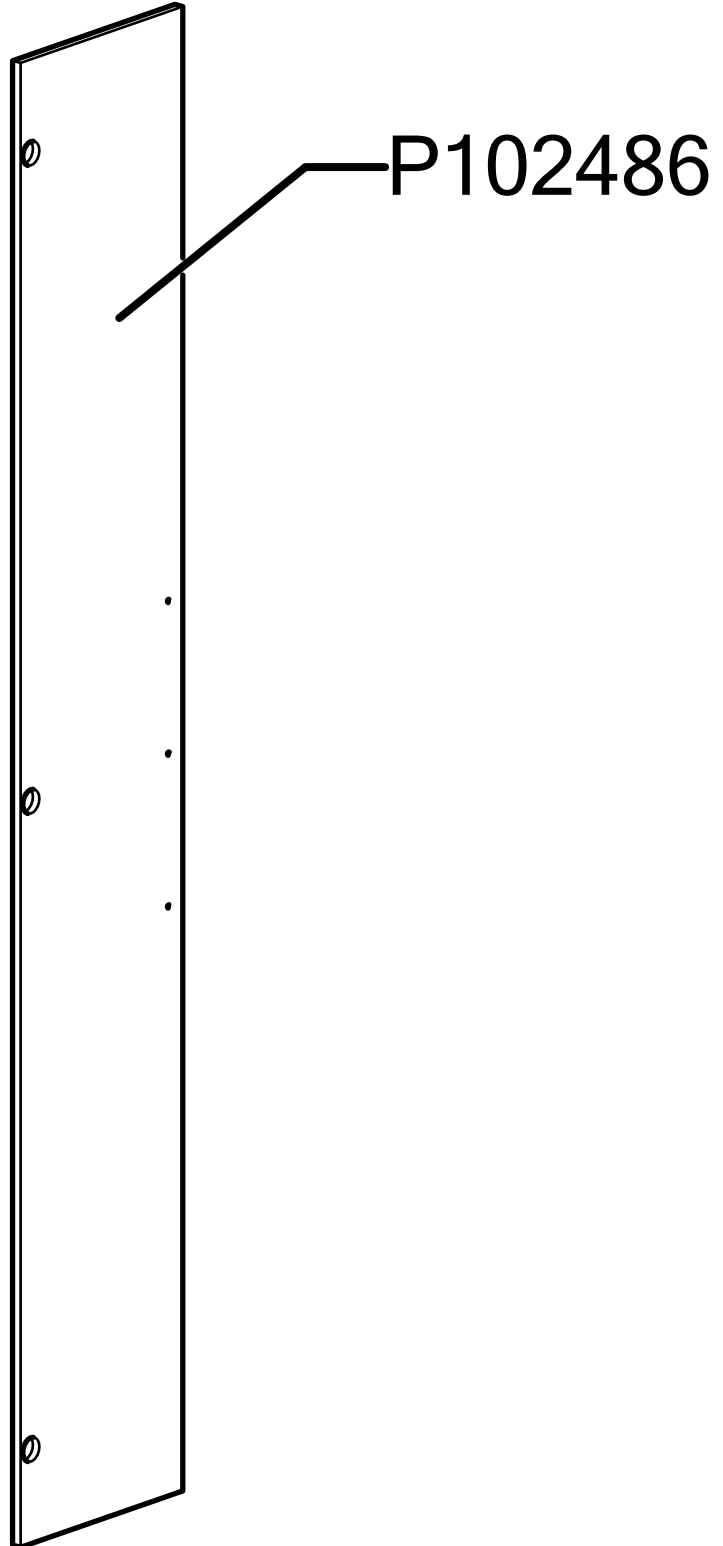

Cod.	Qtde.
P102486	2

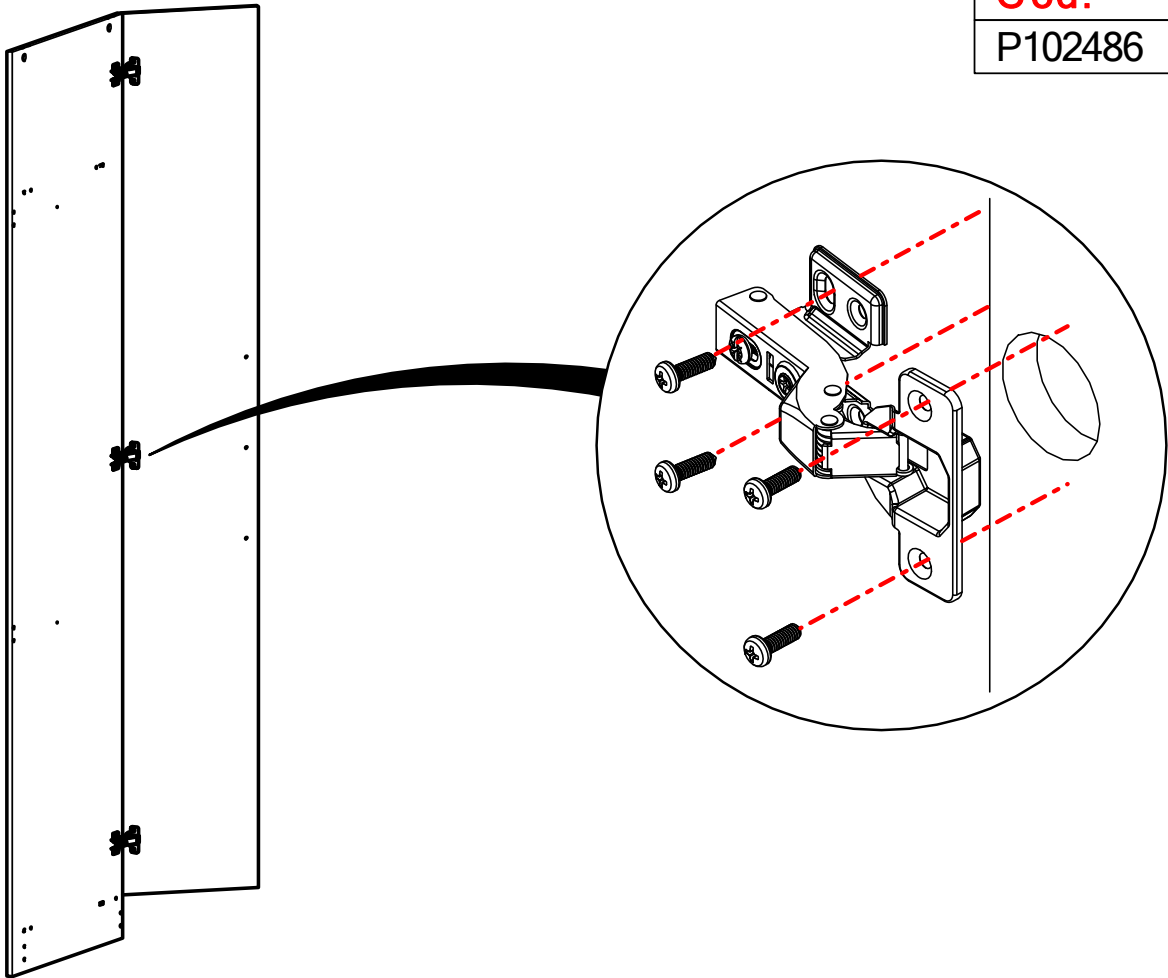

Ajuste de portas
Ajuste de puerta
Doors Adjustment

Ajuste de altura
Height Adjustment

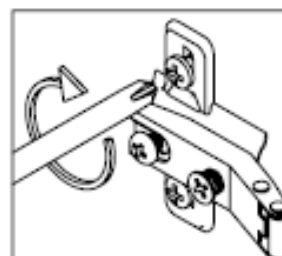
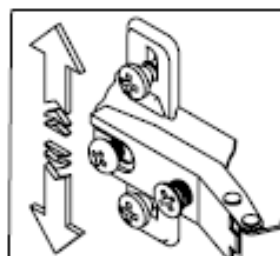
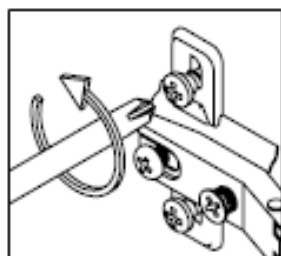
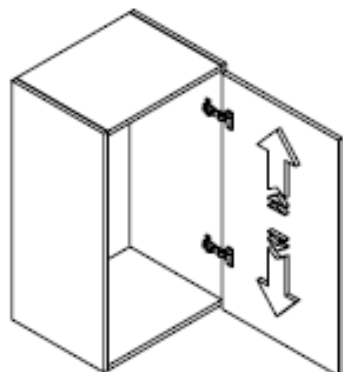

Ajuste Interno
Internal Adjustment

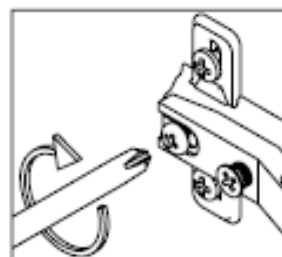
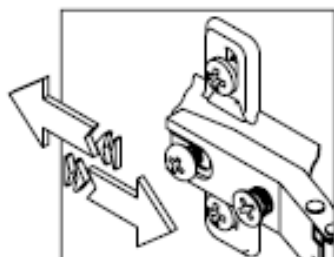
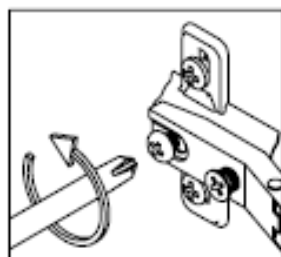
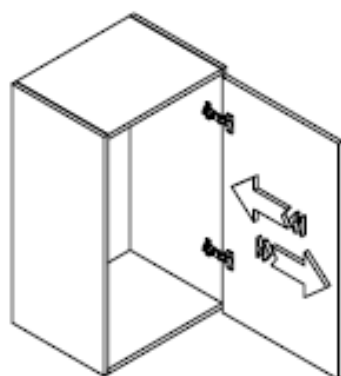

Ajuste de Profundidade
Ajuste de profundidad
Depth Adjustment

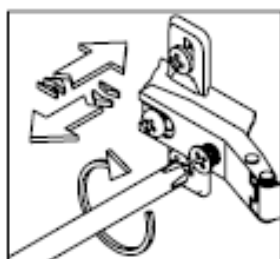
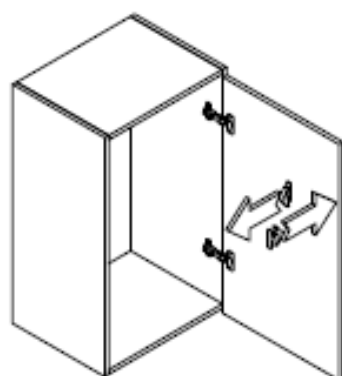

Manual de montagem

Instrucciones de montaje Assembly instructions

2PUX522A-DR

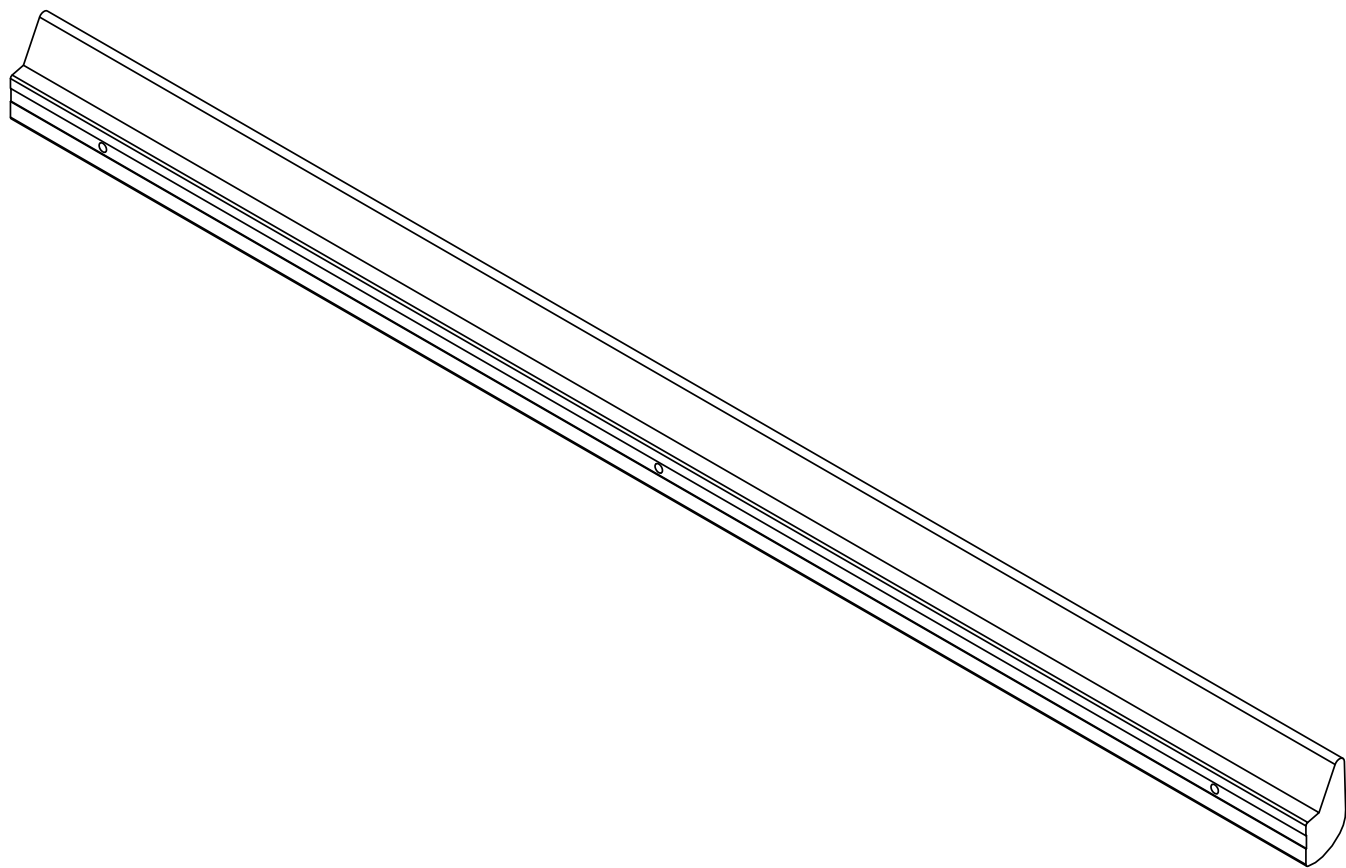

! Imagens meramente ilustrativas !
Imágenes ilustrativas/Images merely illustrative.

Dúvidas? Entre em contato:
Dudas? Ponerse em contacto:
Doubts? Get in touch:
(51) 3635-8839

A montagem deve ser efetuada por 2 pessoas.

El montaje debe ser efectuada por 2 personas.

The assembly must be done by 2 people.

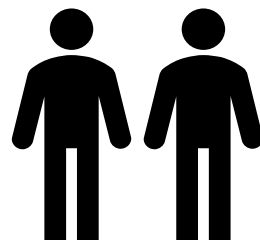

Ferramentas necessárias para montar o móvel.

Herramientas necesarias para armar el mueble.

Tools needed to assemble the furniture.



Dúvidas? Entrar em contato:

Dudas? Ponerse en contacto:

Doubts? Get in touch:

Fone: (51) 3635-8839

www.kappesberg.com.br



Montar o móvel sobre uma superfície limpa e plana.

Armar el mueble sobre una superficie limpia y plana.

Assemble the furniture on a clean, flat surface.

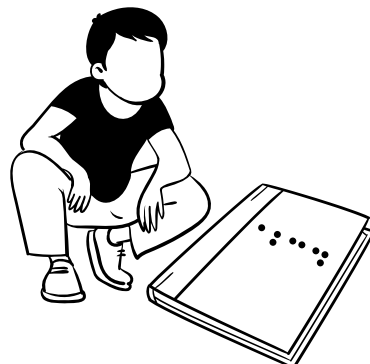

IDENTIFICAÇÃO DOS ACESSÓRIOS / IDENTIFICACIÓN DE ACCESORIOS
IDENTIFICATION OF ACCESSORIES

	Quantidade Cantidad Amount	Código / Code	Descrição	Descripción	Description
	2	076068	PUX. REVESTIDO DOURADO FX120 522MM (224MM EF)	MANILLA DE PUERTA 522MM	PULLER 522MM

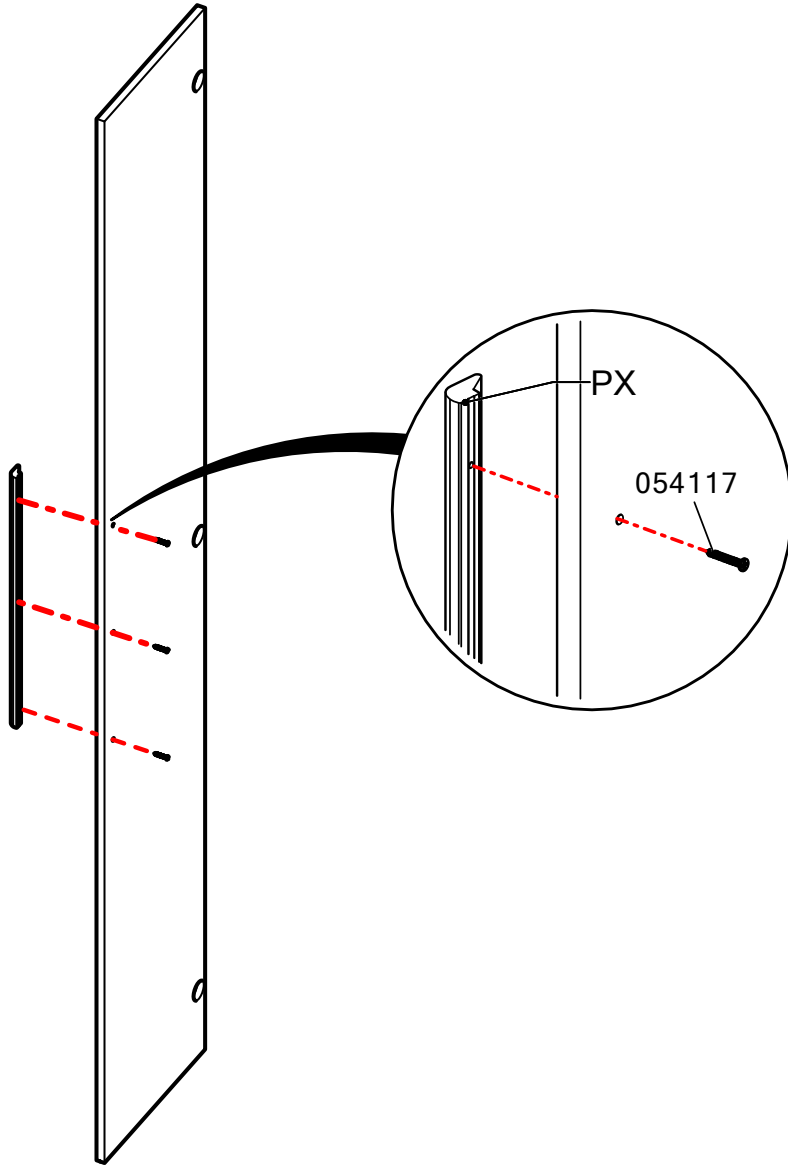

Cod.	Qtde.
054117	6
PX	2