

Manual de montagem

Instrucciones de montaje Assembly instructions

ARM80AMDP

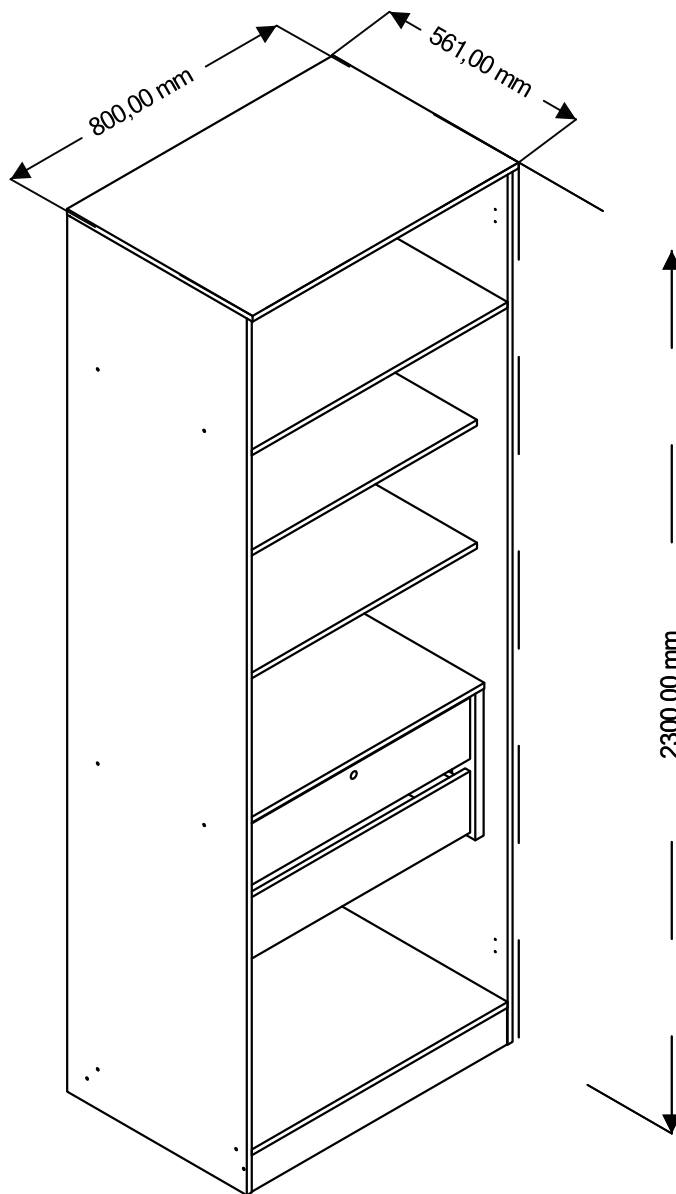

! Imagens meramente ilustrativas !
Imágenes ilustrativas/Images merely illustrative.

Dúvidas? Entre em contato:
Dudas? Ponerse em contacto:
Doubts? Get in touch:
(51) 3635-8839

A montagem deve ser efetuada por 2 pessoas.

El montaje debe ser efectuada por 2 personas.

The assembly must be done by 2 people.

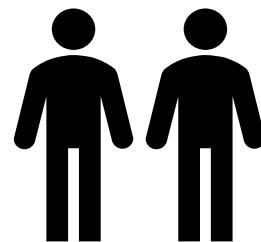

Ferramentas necessárias para montar o móvel.

Tools needed to assemble the furniture.

Herramientas necesarias para armar el mueble.



Dúvidas? Entrar em contato:

Dudas? Ponerse en contacto:

Doubts? Get in touch:

Fone: (51) 3635-8839

www.kappesberg.com.br



Montar o móvel sobre uma superfície limpa e plana.

Armar el mueble sobre una superficie limpia y plana.

Assemble the furniture on a clean, flat surface.

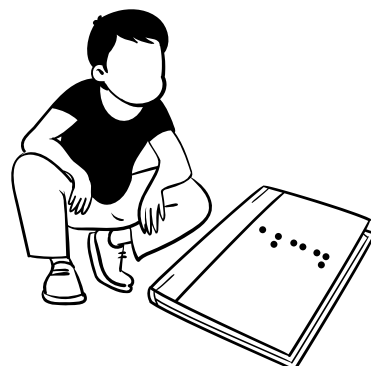

**IDENTIFICAÇÃO DAS PEÇAS / IDENTIFICACIÓN DE LAS PIEZAS PARTS
IDENTIFICATION**

Quantidade Cantidad Amount	Código Code	Descrição	Descripción	Description	C x L x E	L x W x T
1	P102190	LATERAL DIREITA	LADO DIRECTO	RIGHT SIDE	2285 x 540 x 15 mm	89.96 x 21.26 x 0.59 in
2	P102219	BASE	BASE	BASE	769 x 540 x 15 mm	30.28 x 21.26 x 0.59 in
1	P102221	TAMPO DE GAVETA	TAPA DEL CAJON	TOP OF DRAWERS	769 x 470 x 15 mm	30.28 x 18.50 x 0.59 in
2	P102220	PRATELEIRA	ESTANTE	SHELF	769 x 448 x 15 mm	30.28 x 17.64 x 0.59 in
1	P102218	CHAPÉU	SOMBRERO	HAT	800 x 558 x 15 mm	31.50 x 21.97 x 0.59 in
1	P102209	LATERAL ESQUERDA	LADO IZQUERDA	LEFT SIDE	2285 x 540 x 15 mm	89.96 x 21.26 x 0.59 in
2	P102222	RODAPE	ZOCALO	BASEBOARD	769 x 96 x 15 mm	30.28 x 3.78 x 0.59 in
2	P102231	COSTA	COSTA	COAST	2194 x 390 x 3 mm	86.38 x 15.35 x 0.12 in
4	P102202	LATERAL DE GAVETA	LADO DEL CAJÓN	DRAWER SIDE	400 x 120 x 15 mm	15.75 x 4.72 x 0.59 in
2	P102254	FUNDO DE GAVETA	FONDO DEL CAJÓN	DRAWER BOTTOM	678 x 398 x 3 mm	26.69 x 15.67 x 0.12 in
2	P102253	CABECEIRA DE GAVETA	CABEZAL DEL CAJÓN	DRAWER HEAD	665 x 120 x 15 mm	26.18 x 4.72 x 0.59 in
1	P102553	FRENTE DE GAVETA	FRENTE DEL CAJÓN	DRAWER FRONT	700 x 160 x 15 mm	27.56 x 6.30 x 0.59 in
4	P102206	AFASTADOR	RETRACTOR	SEPARADOR	384 x 70 x 25 mm	15.12 x 2.76 x 0.98 in
1	P102256	FRENTE DE GAVETA	FRENTE DEL CAJÓN	DRAWER FRONT	700 x 160 x 15 mm	27.56 x 6.30 x 0.59 in

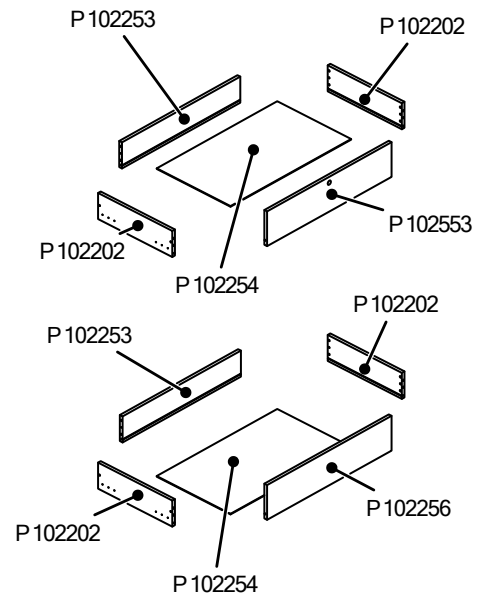
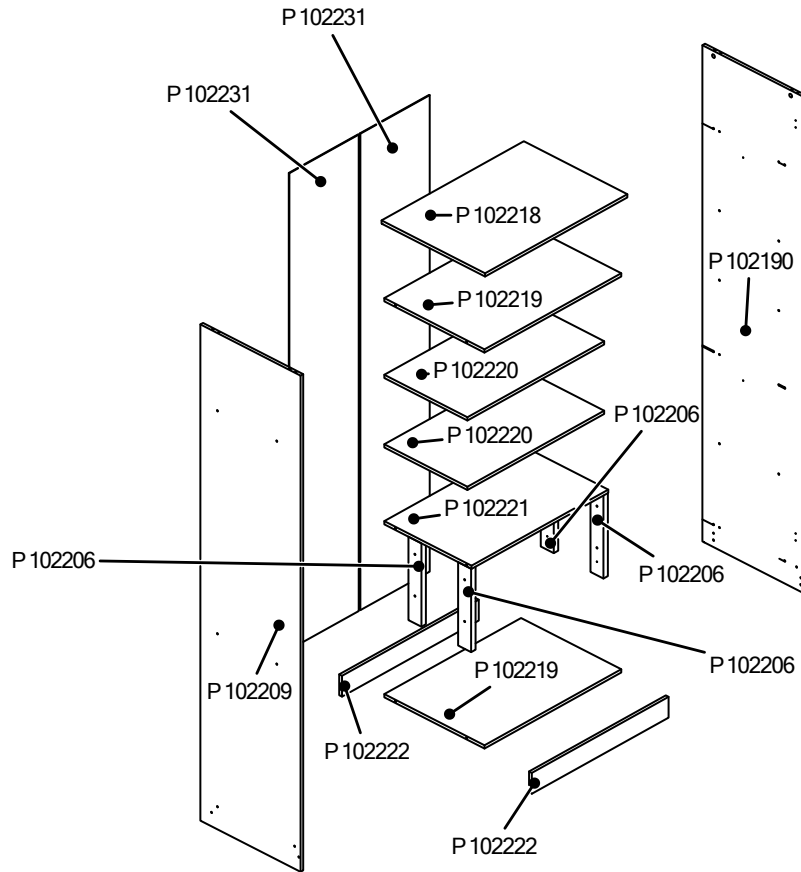

IDENTIFICAÇÃO DOS ACESSÓRIOS / IDENTIFICACIÓN DE ACCESORIOS
IDENTIFICATION OF ACCESSORIES

NOTAS: A separação dos acessórios antes de iniciar a montagem facilitará a mesma. Em caso de dúvida na identificação, coloque o acessório sobre a régua.

Nota: Separar los accesorios antes de iniciar el montaje facilitará el mismo. En caso de duda en la identificación, coloque el accesorio en la regla.

NOTE: Separating the accessories before starting assembly will make it easier. In case of doubt in the identification, place the accessory on the ruler.

	Quantidade / Cantidad / Amount	Código / Code	Descrição	Descripción	Description
	6	054117	P.CHATO 3,5 X 25 CAB. PHILLIPS ZB/BC (IDELLI)	TORNILLO 3,5 X 25	SCREW 3,5 X 25
	40	001802	CAVILHAS DE MADEIRA 6X30 PINUS	TARUGO 6X30MM	DOWEL 6X30MM
	20	000226	P.CHATO 4,0 X 40MM	TORNILLO 4,0 X 40MM	SCREW 4,0 X 40MM
	4	030950	TAMBOR P/ MINIFIX 15MM ZAMAQ 09.11.007	CILINDRO 15MM	BARREL 15MM
	4	030945	PARAFUSO DE ACO P/ MINIFIX	TORNILLO DE ACERO PARA MINIFIX	STEEL SCREW FOR MINIFIX
	8	000118	SUP. P/ PRAT. 6 X 8MM BEGE (COR 004)	SOPORTE DE ESTANTE 6 X 8	SHELF SUPPORT 6 X 8
	16	TAPA FURO 13MM	TAPA FURO 13MM	TAPA DEL AGUJERO 13MM	SCREW CAP COVER 13MM
	4	TAPA FURO 19MM	TAPA FURO 19MM	TAPA DEL AGUJERO 19MM	SCREW CAP COVER 19MM
	36	061971	P.PANELA 4,0 X 14 ZB P/DOBRADICA	TORNILLO 4,0 X 14	SCREW 4,0 X 14

IDENTIFICAÇÃO DOS ACESSÓRIOS / IDENTIFICACIÓN DE ACCESORIOS IDENTIFICATION OF ACCESSORIES

	6	059614	DOBRAD. CURVA 35MM C/ CALCO FIXO E AMORTECEDOR	BISAGRA DE CALCE	HINGE AND SHIM
	4	001901	SAPATA DESLIZADORA PRETA 15 X 6 (02.02.026)	ZAPATO 15 X 6	SHOE 15 X 6
	4	000108	PREGO 12 X 12 (0,6127G) ARDOX	CLAVO 12 X 12	NAIL 12 X 12
	70	000107	PREGO 10 X 10 (0,308G) LISO	CLAVO 10 X 10	NAIL 10 X 10
	54	004214	P.CHATO 3,5 X 14 CAB. PHILLIPS REBAIXADA ZB	TORNILLO 3,5 X 14MM	SCREW 3,5 X 14MM
	6	000899	CANTONEIRA PLASTICA PRETA	CANTONERA	PLASTIC HANDLE
	1	001622	L DE ENGATE 04.08.027	ENGANCHE L	L HITCH
	2	038305	CORREDICA TELESCOPICO MINI LIGHT (H32/30) 400MM	CORREDERA METÁLICA 400MM	METAL SLIDE 400MM
	8	000414	P.PANELA 4,0 X 35 CAB. PHILLIPS ZB/BC	TORNILLO 4,0 X 35	SCREW 4,0 X 35
	1	001620	FECHAD. P/ GAVETA 65020861-01 CHAVE CAPA	CERRADURA DE CAJÓN	DRAWER LOCK
	4	018458	SUPORTE TRIANGULAR PRETO	SOPORTE TRIANGULO NEGRO	BLACK TRIANGLE SUPPORT
	4	005256	PARAFUSO CHATO 4,0 X 20 BC	TORNILLO PLANO 4,0 X 20 BC	FLAT SCREW 4,0 X 20 BC
	1	PH	PERF. H26 2190MM CARVALLE	PERFIL H 2190MM	PROFILE H 2190MM

INSTALAÇÃO MINIFIX

Identificar seta no corpo do tambor de minifix. A seta DEVE apontar para o buraco na borda do painel. Empurrar o tambor até o buraco.

INSTALACIÓN DE LA LEVA

Identifique la flecha en los muertos de la leva. La flecha debe apuntar hacia el agujero en el borde del panel. Empuje la leva hasta el fondo del orificio.

INSTALLING CAM

Identify arrow on head of cam. Arrow MUST point toward hole in edge of panel. Push cam all the way down into hole.

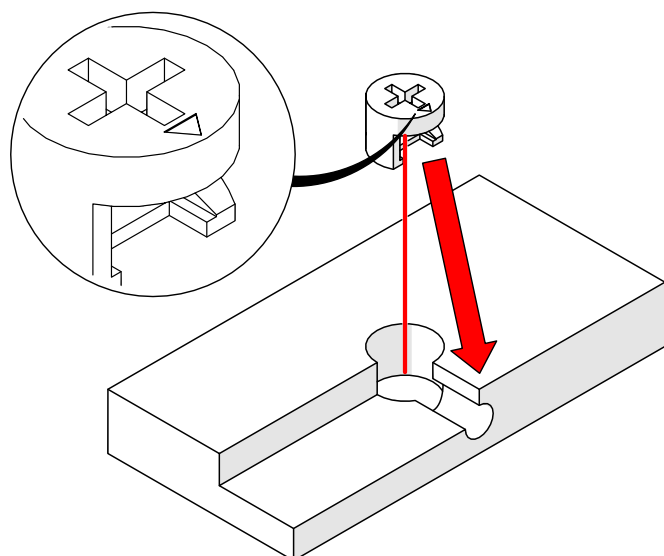

ALINHAMENTO DO TAMBOR E PARAFUSO

A seta do tambor de minifix deve ser aponta para o buraco e inserir o parafuso do minifix do tambor contido no buraco. Certifique-se de que as peças se unam.

ALINEACIÓN DE LA LEVA Y EL PASADOR

Asegúrese de que la flecha de la leva apunte hacia el orificio e inserte la clavija de la leva en el orificio. Asegúrese de que las piezas se unen.

CAM AND DOWEL ALIGNMENT

Ensure the arrow on the cam points toward hole and insert cam dowel into hole. Make sure pieces join together.

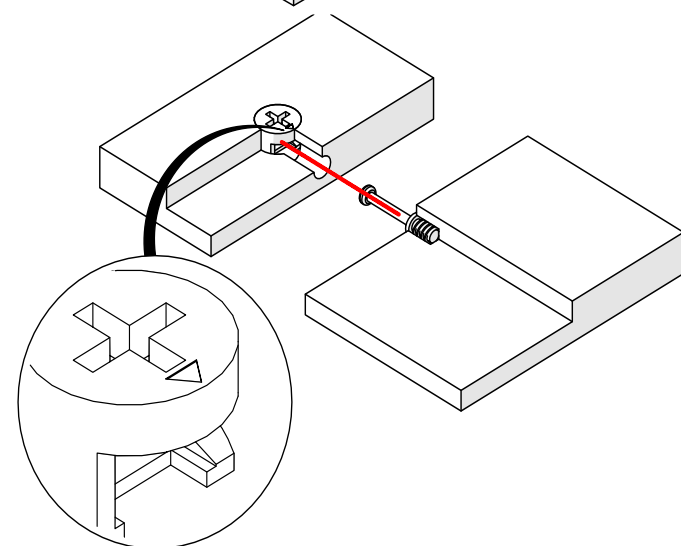

CÂMARA DE COMPENSAÇÃO DE TENSÃO

Use uma chave de fenda para girar a came. Girar o tambor minifix (no sentido horário) até que esteja totalmente apertado. Ligeiramente mais de meia volta.

APRIETE DE LA LEVA

Utilice un destornillador para girar la leva. Gire la leva (en el sentido de las agujas del reloj) hasta que esté completamente apretada. Un poco más de media vuelta.

TIGHTENING CAM

Use screwdriver to turn cam. Turn cam (clockwise) until fully tightened. Slightly more than half a turn.

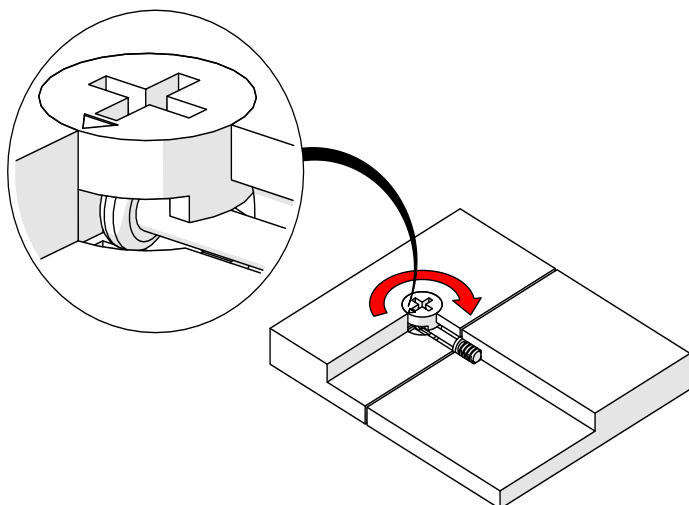

PASSO / PASO / STEP 1

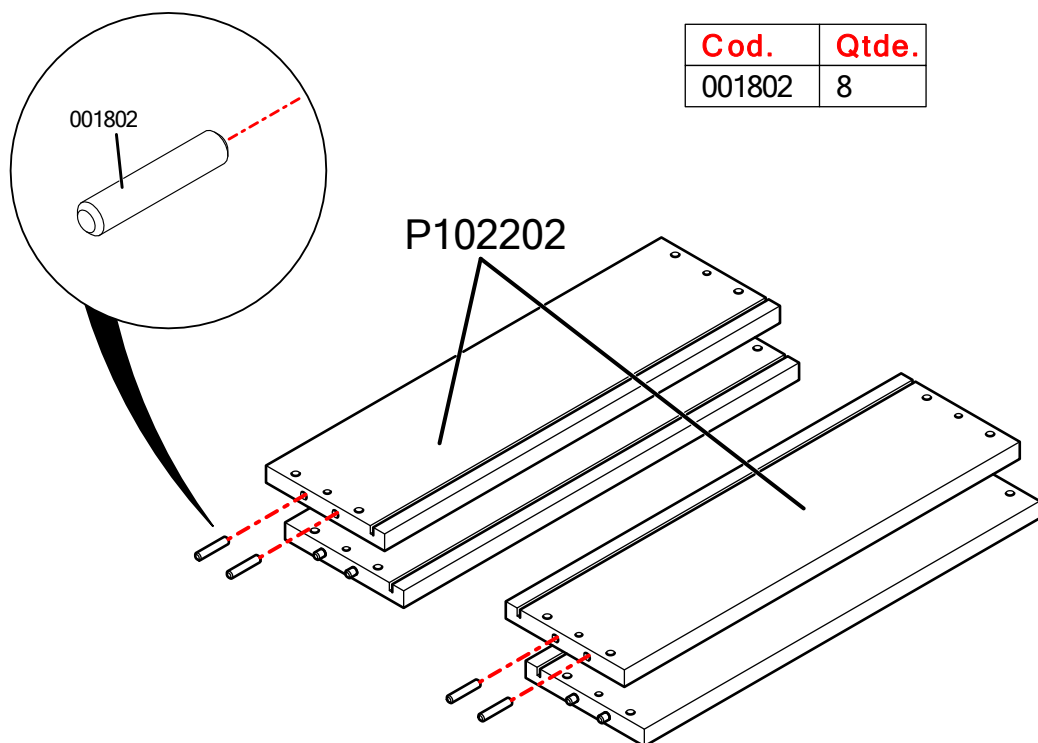

Cod.	Qtde.
001802	8

PASSO / PASO / STEP 2

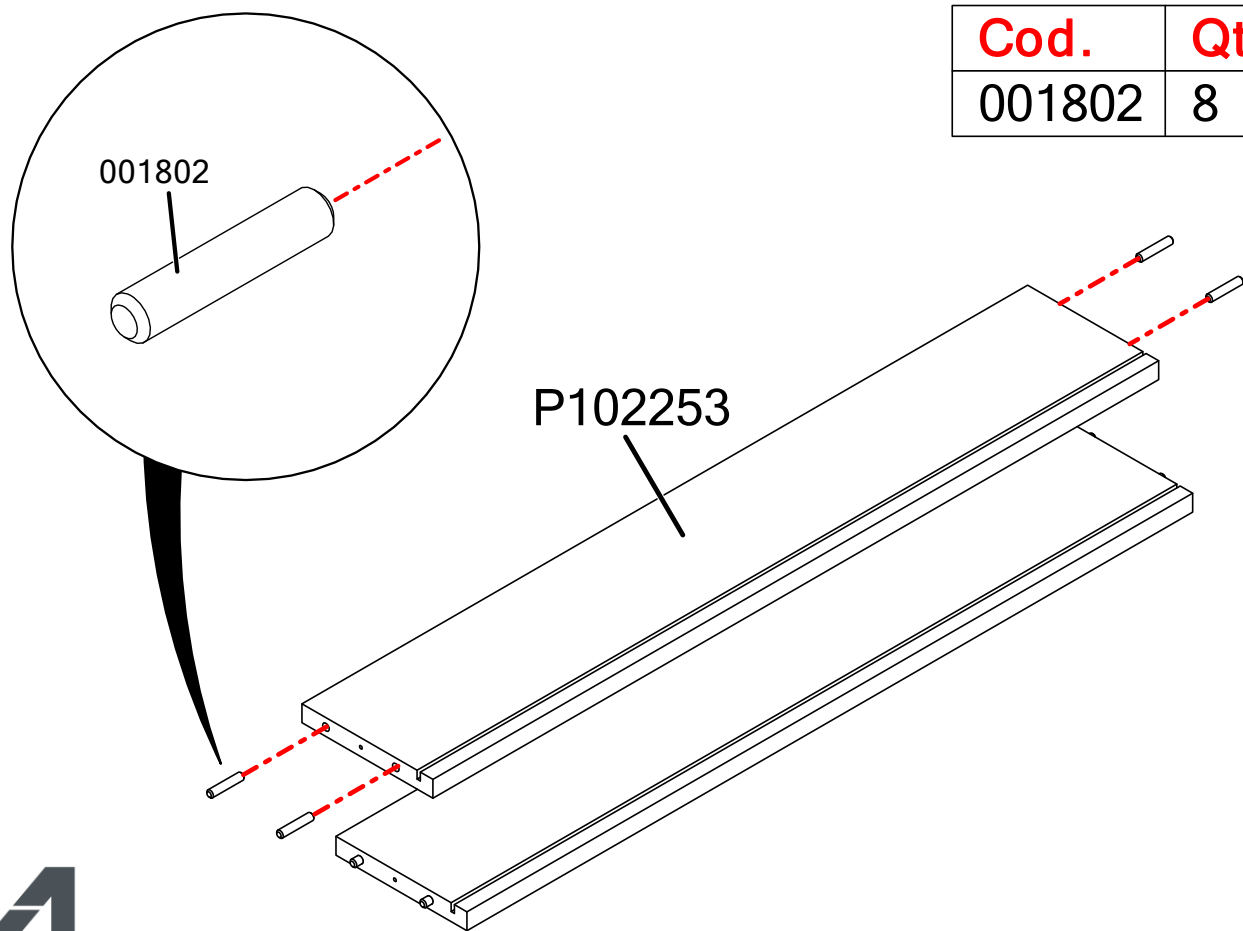

Cod.	Qtde.
001802	8

ARM80AMDP

PASSO / PASO / STEP 3

Cod.	Qtde.
000226	4

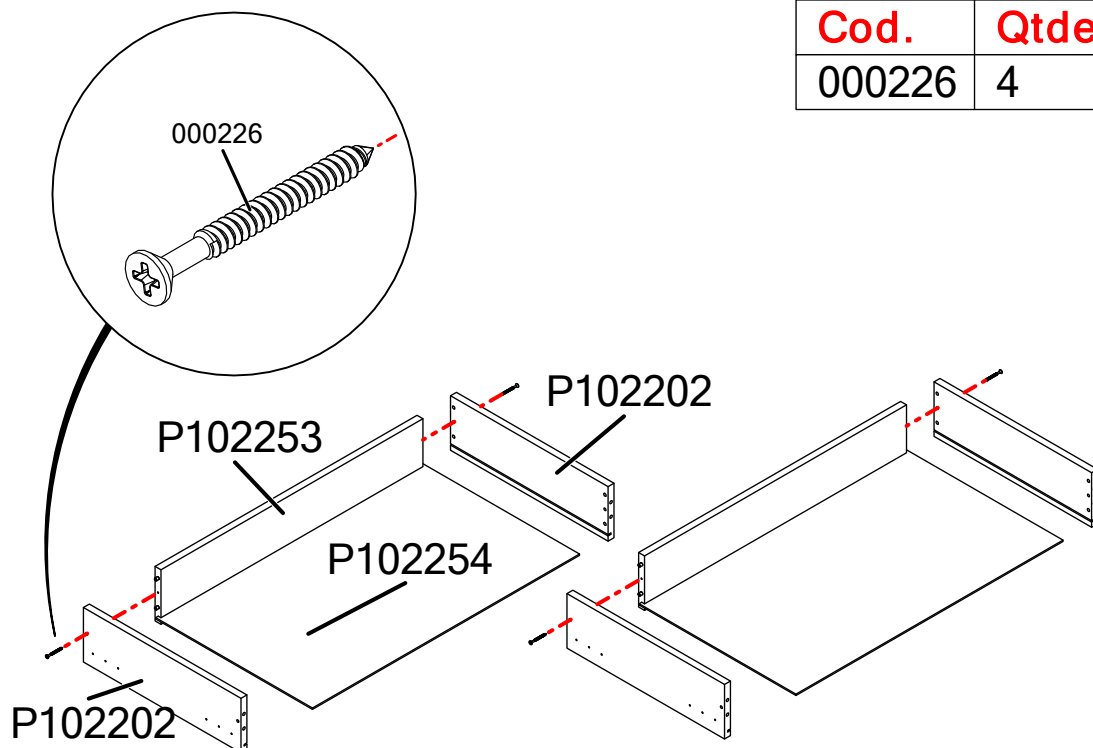

PASSO / PASO / STEP 4

Cod.	Qtde.
004214	16
000899	4

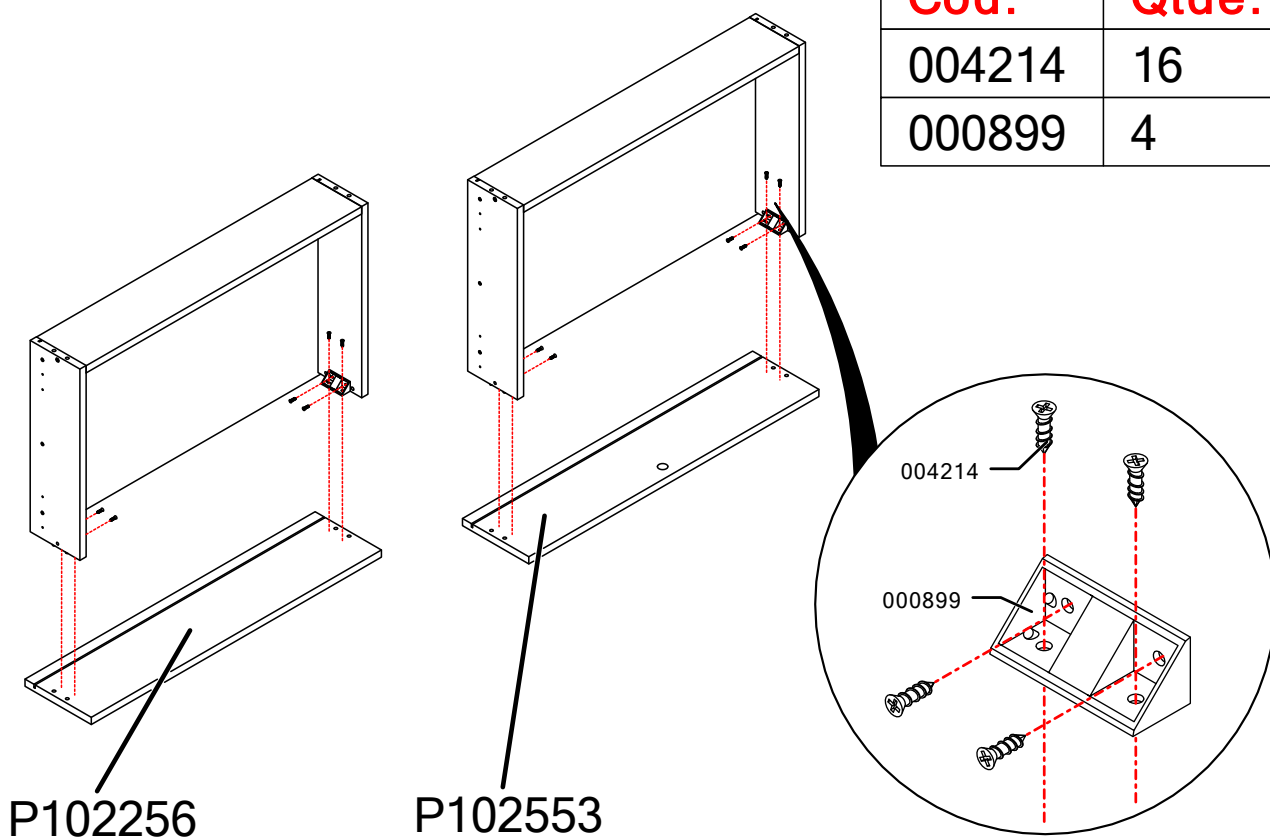

PASSO / PASO / STEP 5

Cod.	Qtde.
004214	2
001620	1

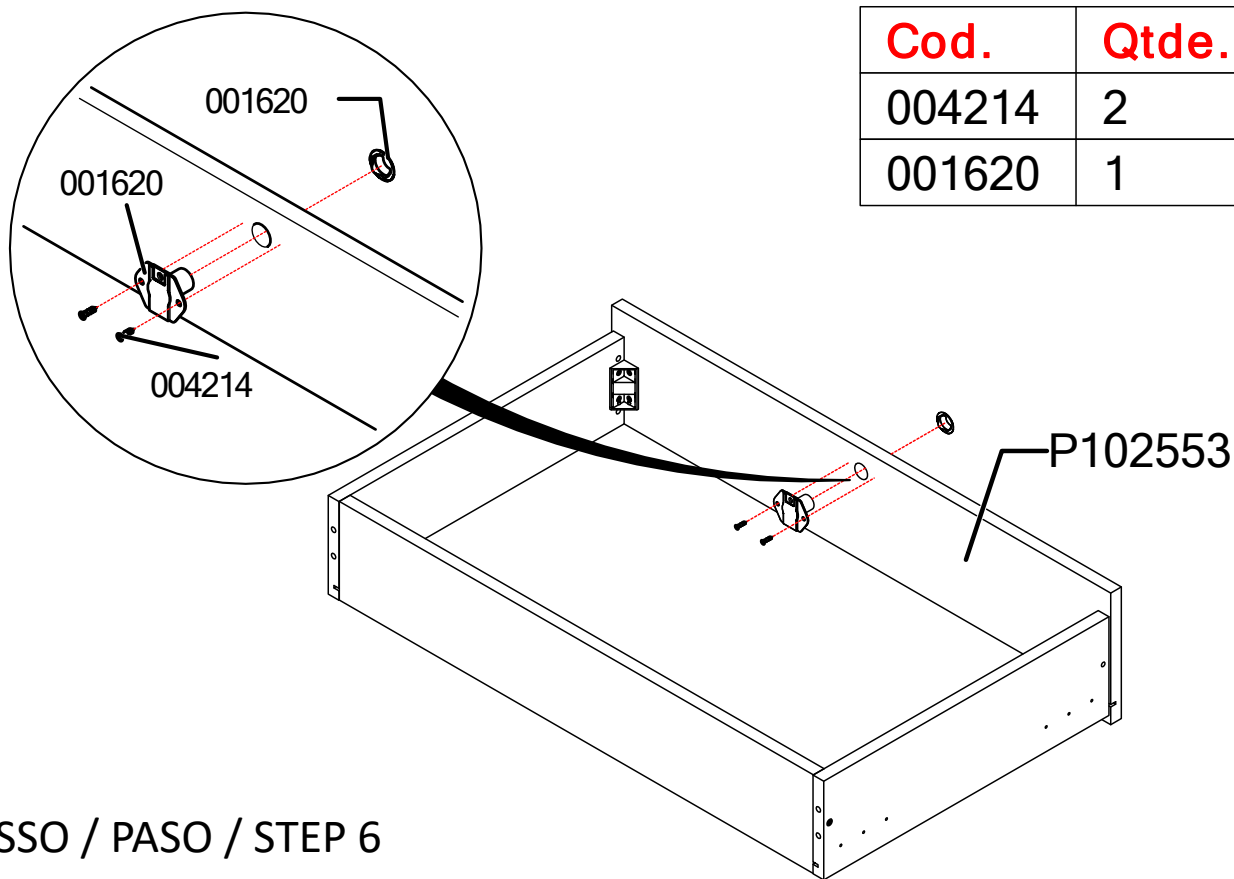

PASSO / PASO / STEP 6

Cod.	Qtde.
018458	4
005256	4

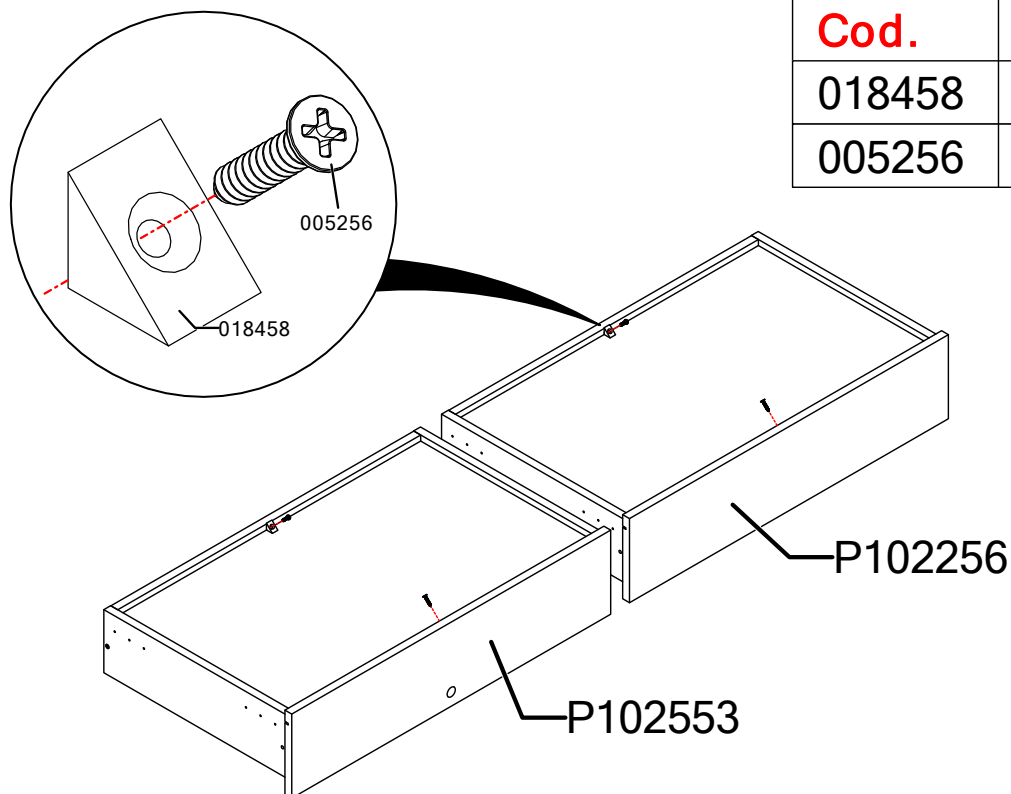

PASSO / PASO / STEP 7

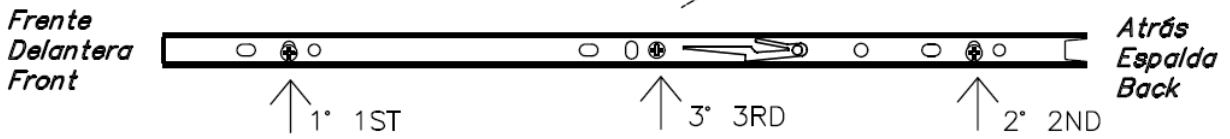
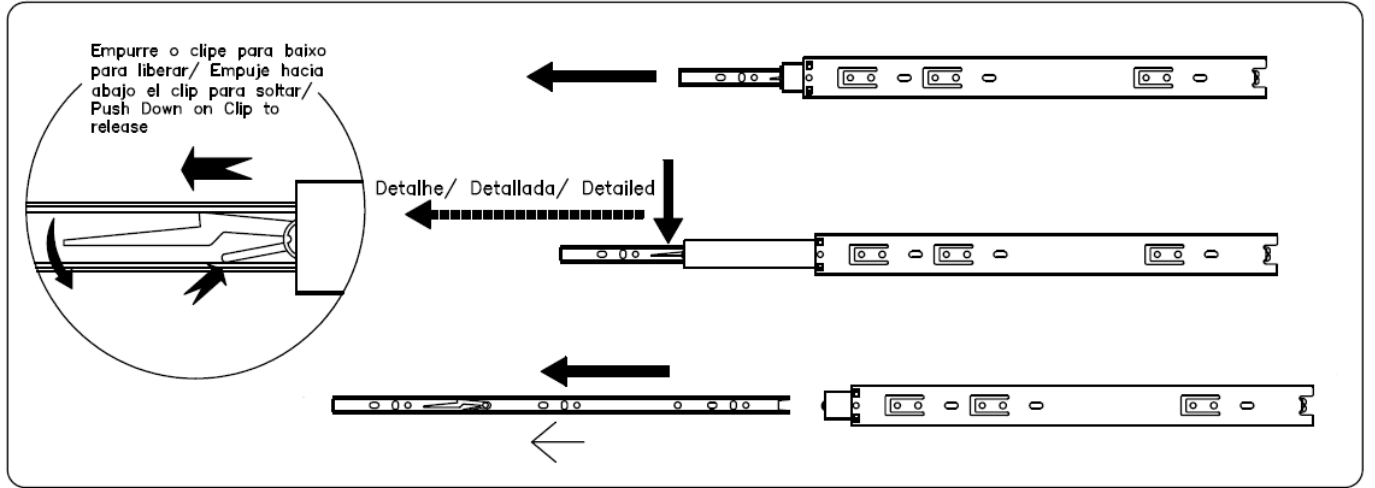

PASSO / PASO / STEP 8

Cod.	Qtde.
004214	12
038305	2

Atrás / Espalda /

Central / Centro /

Frente / Delantera

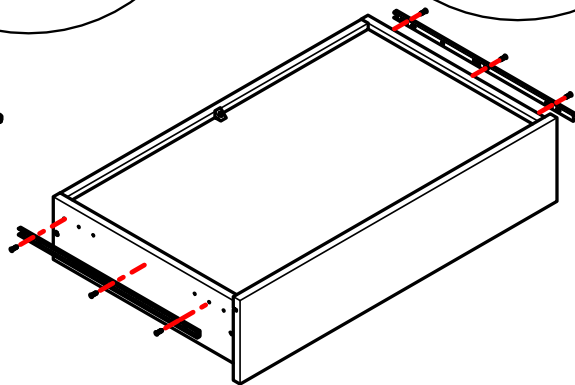
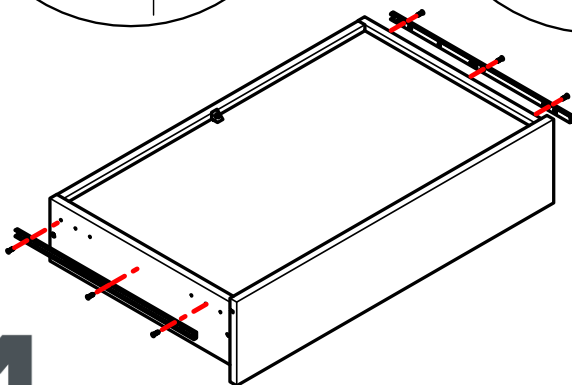
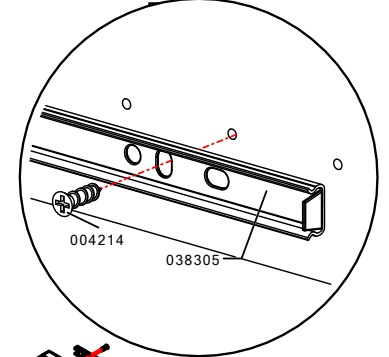
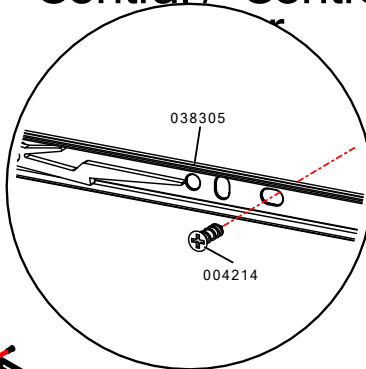
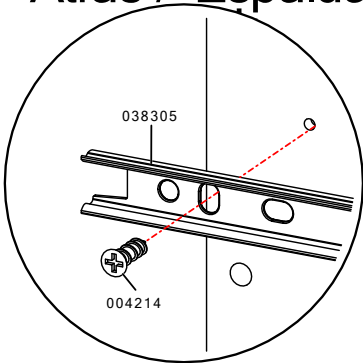

ARM80AMDP

PASSO / PASO / STEP 9

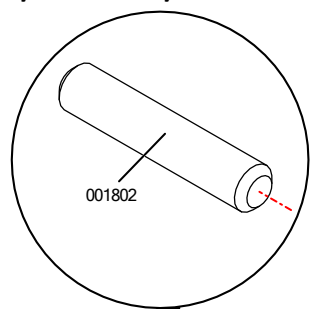

Cod.	Qtde.
001802	2
000118	4

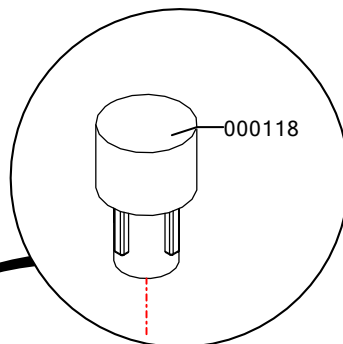

P102190

PASSO / PASO / STEP 10

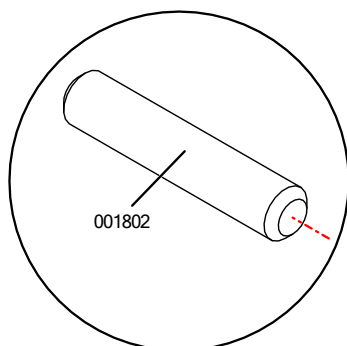

Cod.	Qtde.
001802	2
000118	4

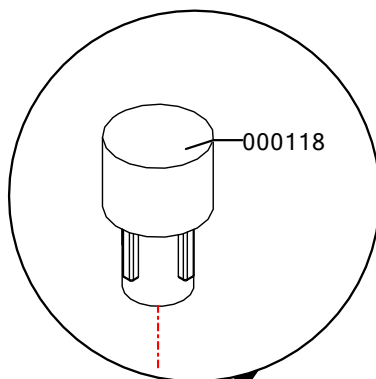

P102209

ARM80AMDP

PASSO / PASO / STEP 11

Cod.	Qtde.
001802	4

P102222

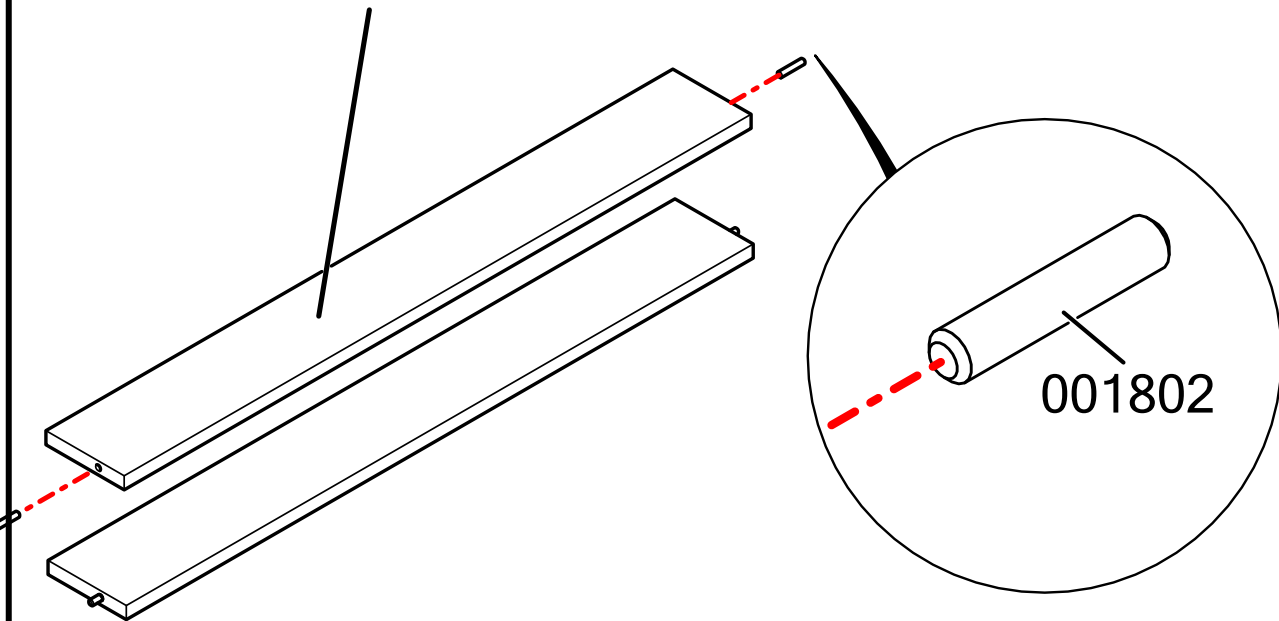

PASSO / PASO / STEP 12

Cod.	Qtde.
001802	8

P102219

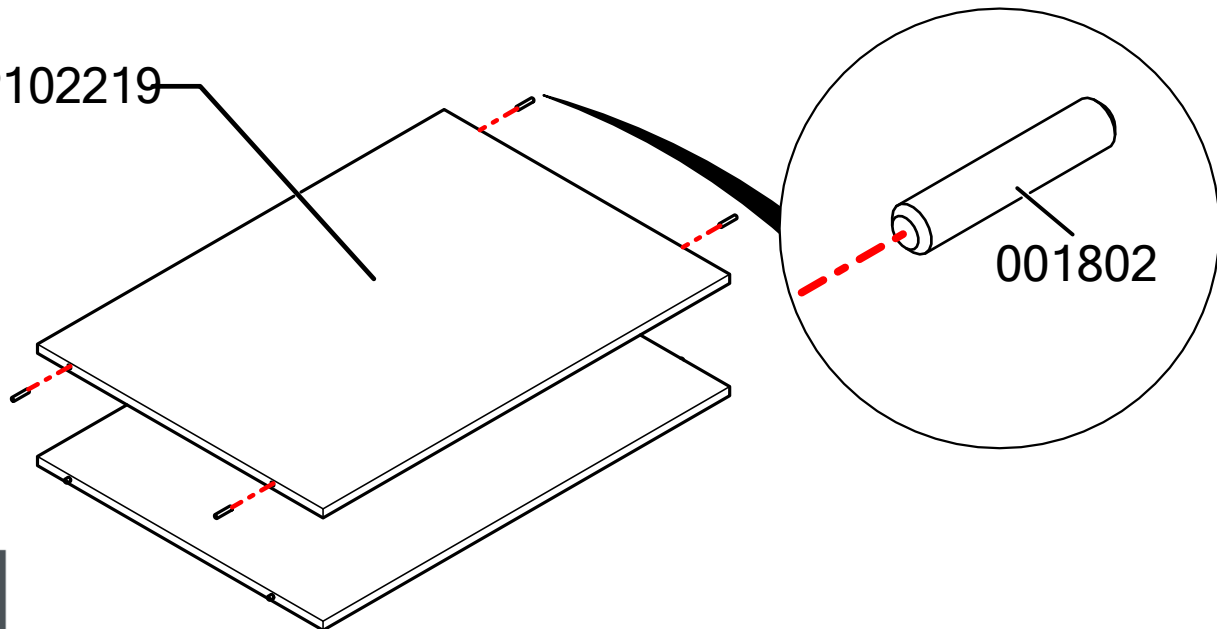

ARM80AMDP

PASSO / PASO / STEP 13

Cod.	Qtde.
030945	4

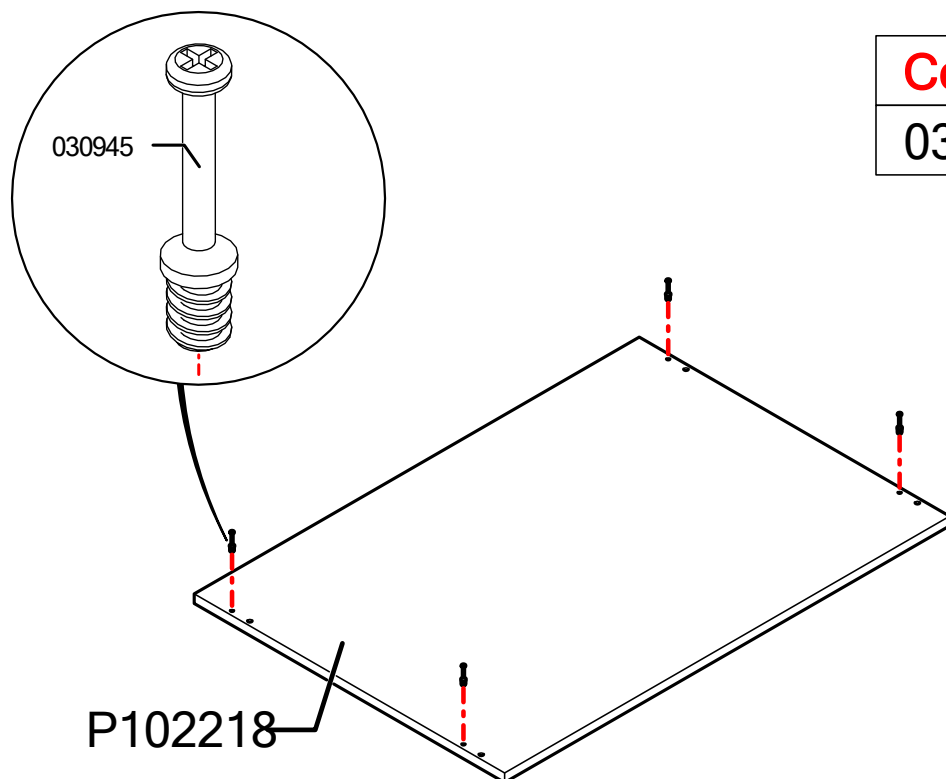

PASSO / PASO / STEP 14

Cod.	Qtde.
001802	4

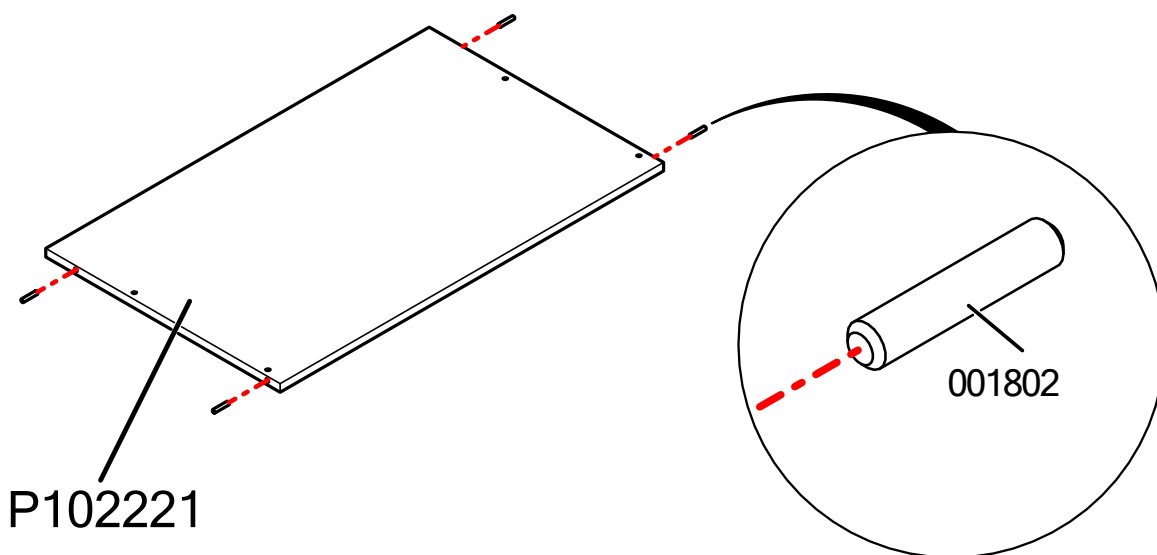

PASSO / PASO / STEP 15

Cod.	Qtde.
001802	4

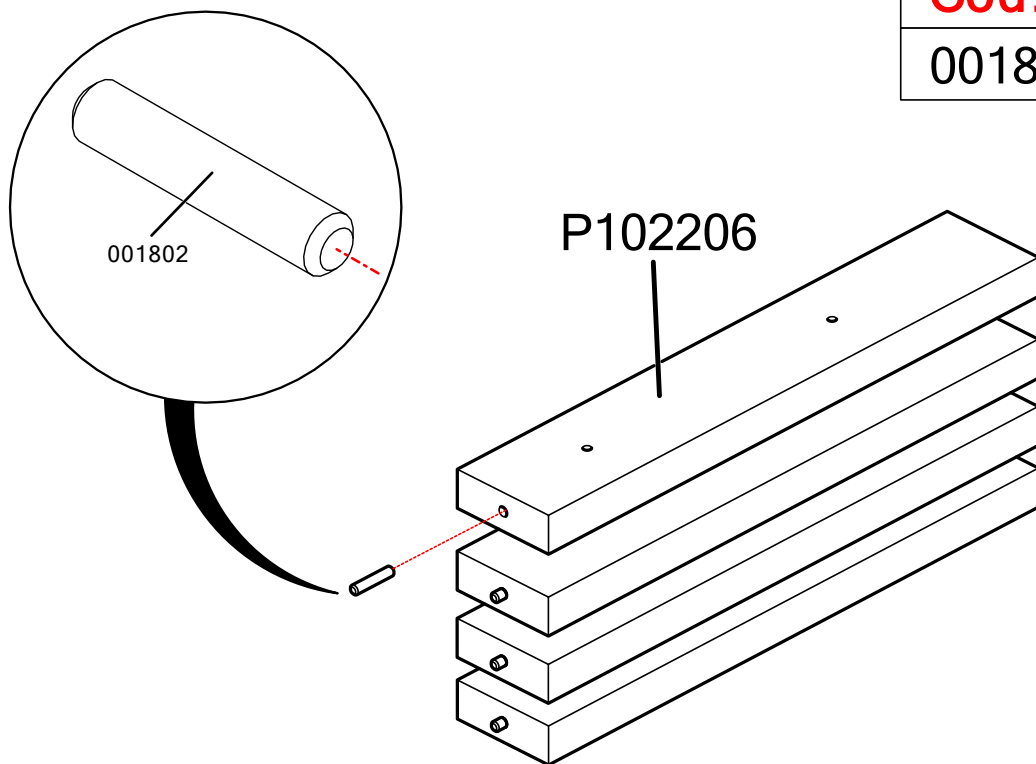

PASSO / PASO / STEP 16

Cod.	Qtde.
TAPA FURO 13MM	16
004214	8
000899	2
000226	16

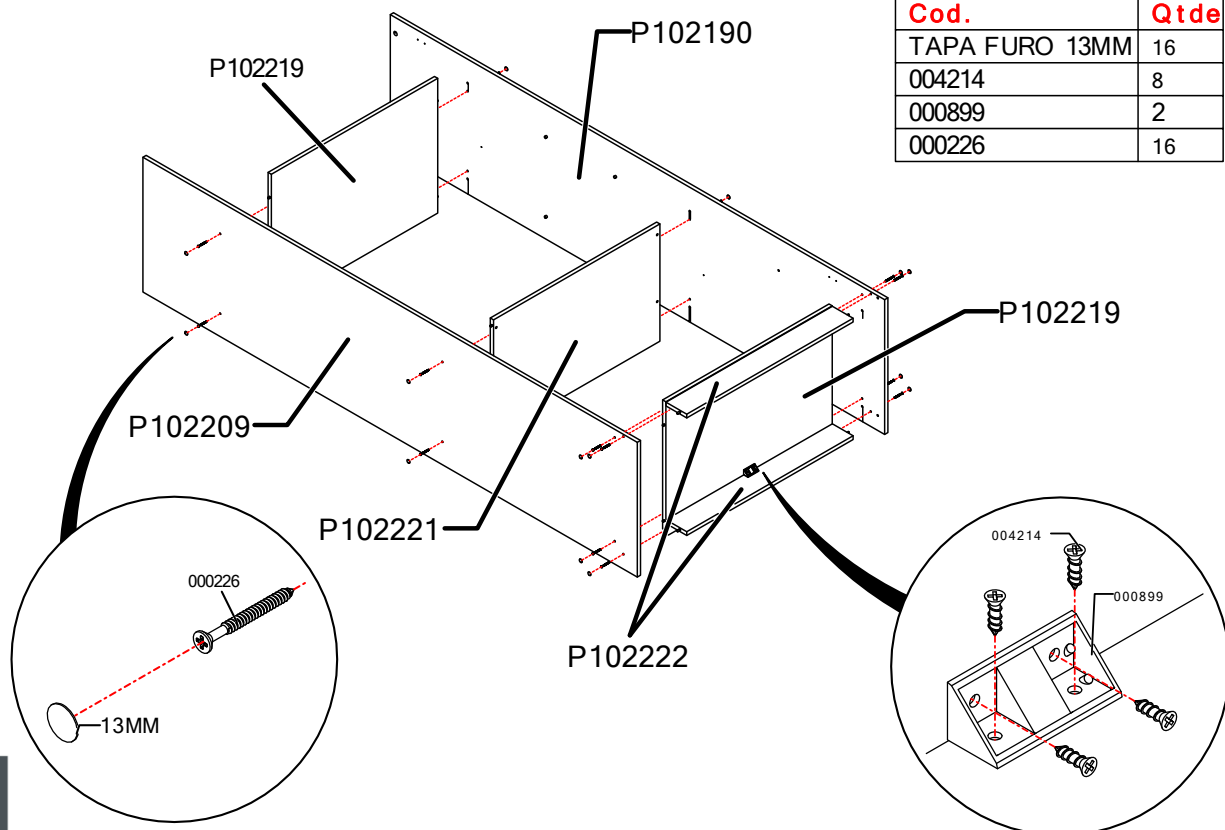

ARM80AMDP

PASSO / PASO / STEP 17

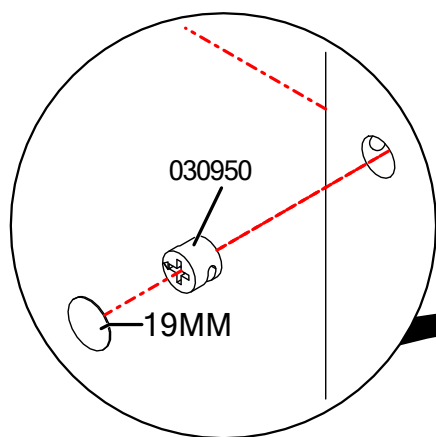

P102218

Cod.	Qtde.
TAPA FURO 19MM	4
030950	4

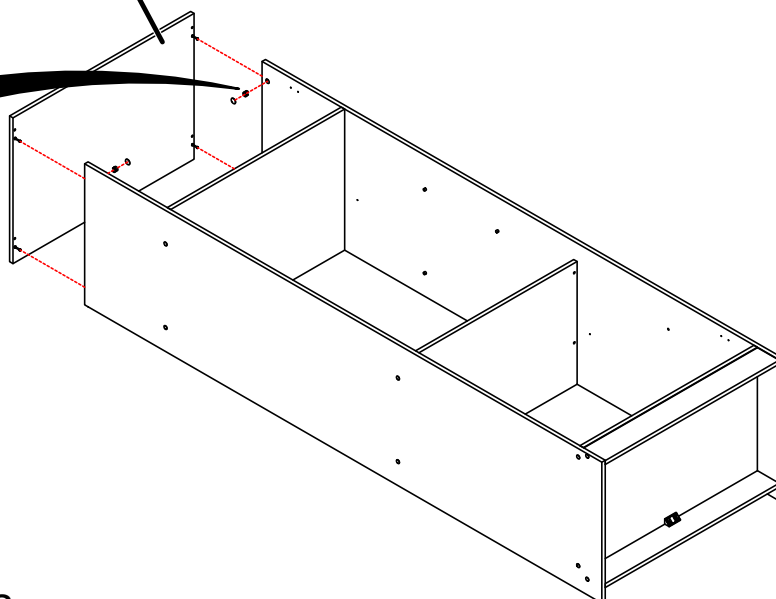

PASSO / PASO / STEP 18

Cod.	Qtde.
001901	4
000108	4

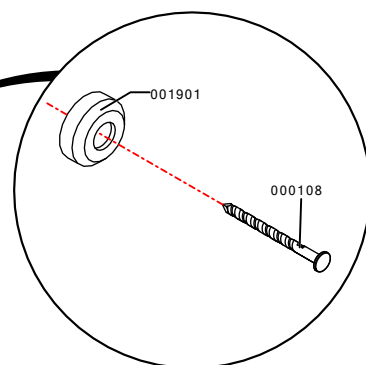
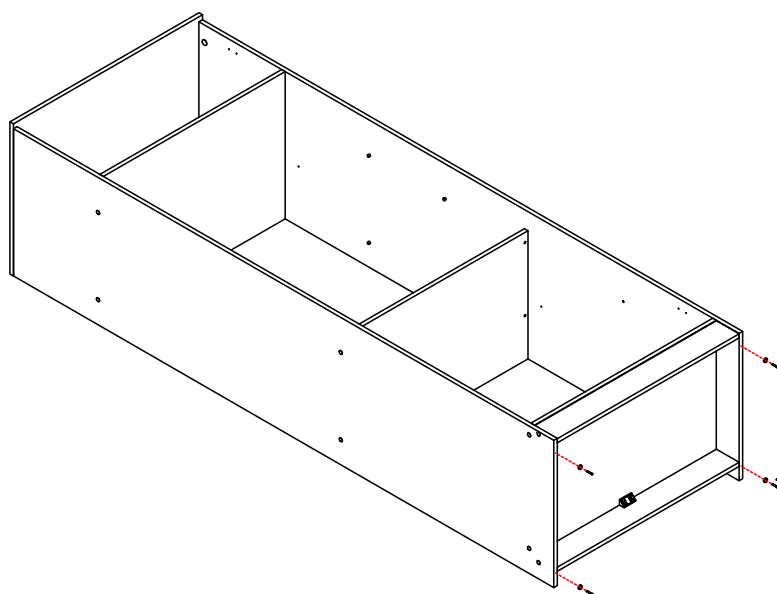

PASSO / PASO / STEP 19

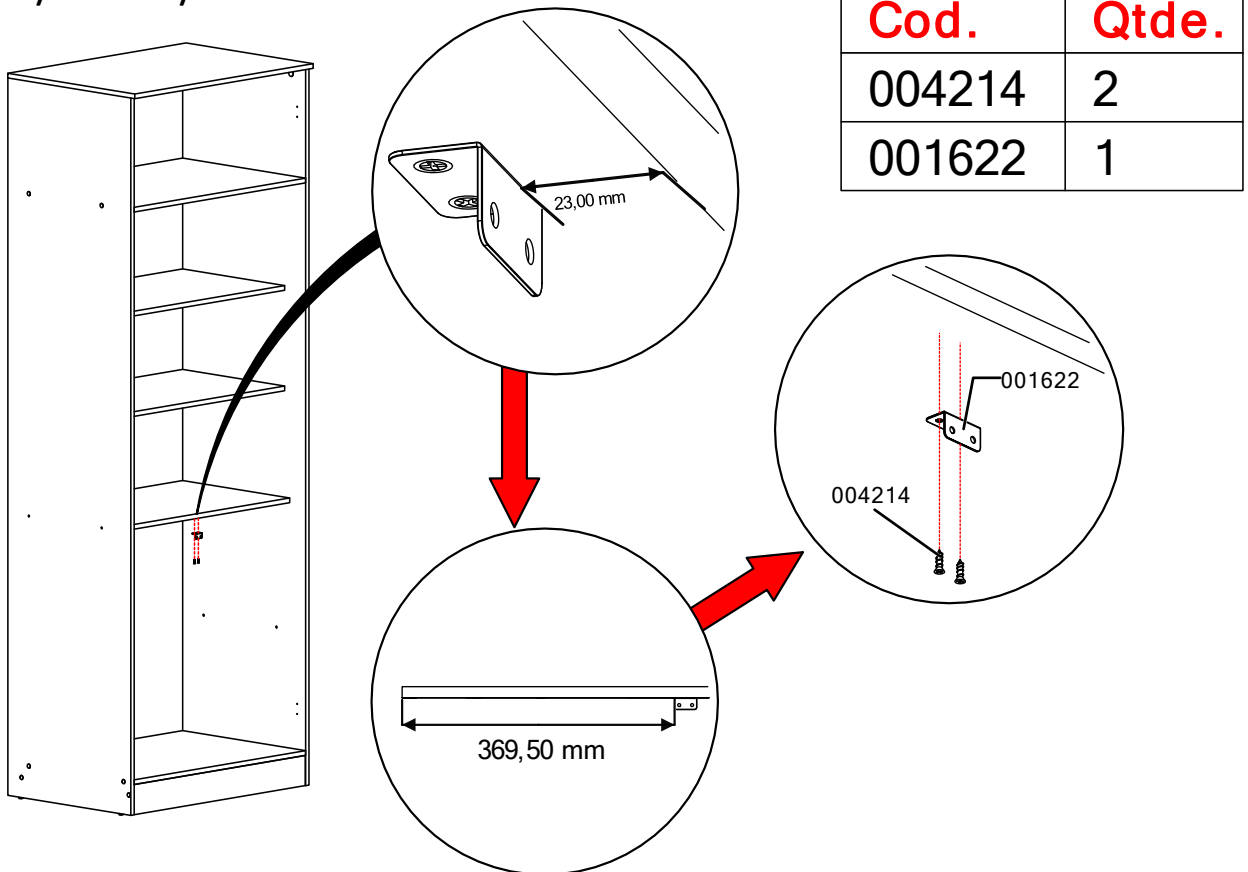

PASSO / PASO / STEP 20

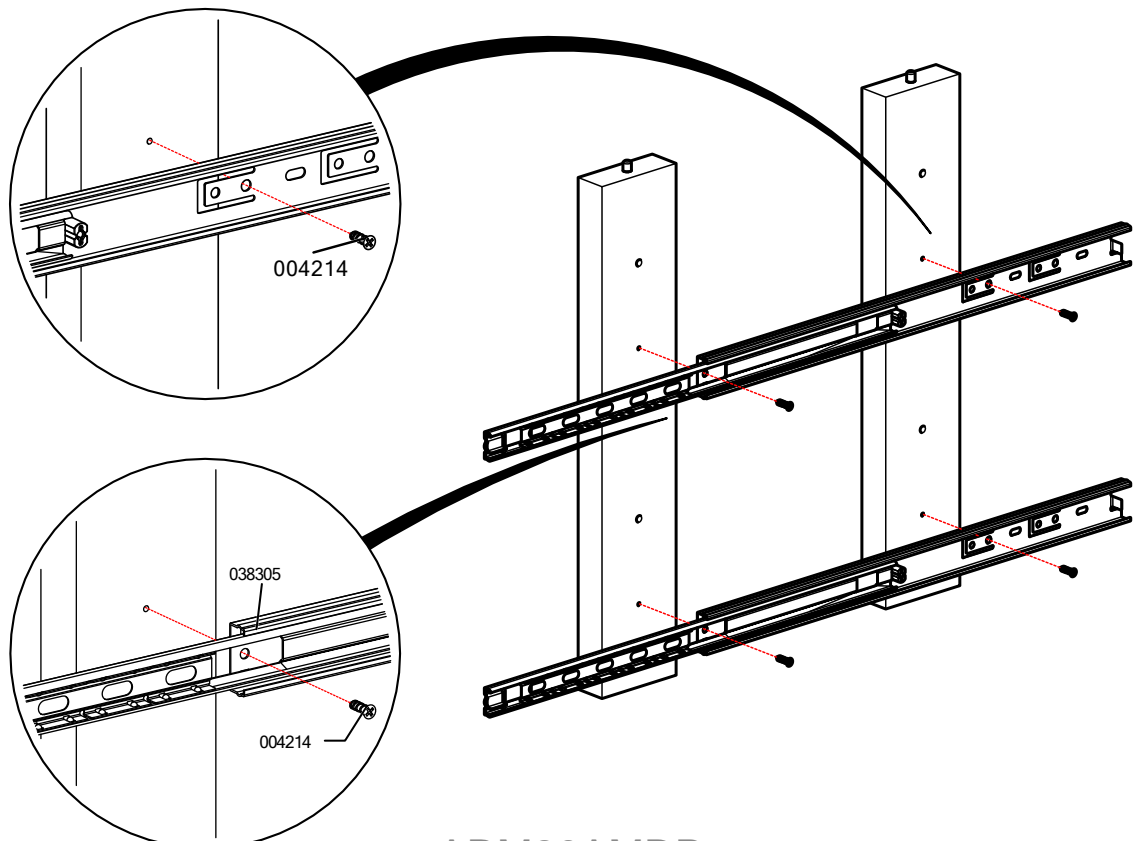

ARM80AMDP

PASSO / PASO / STEP 21

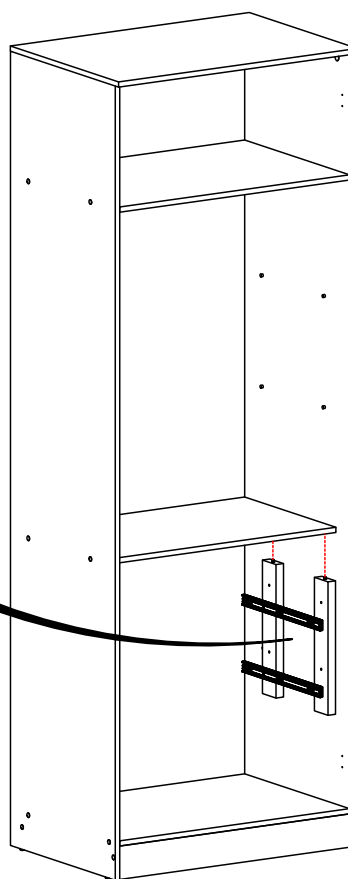
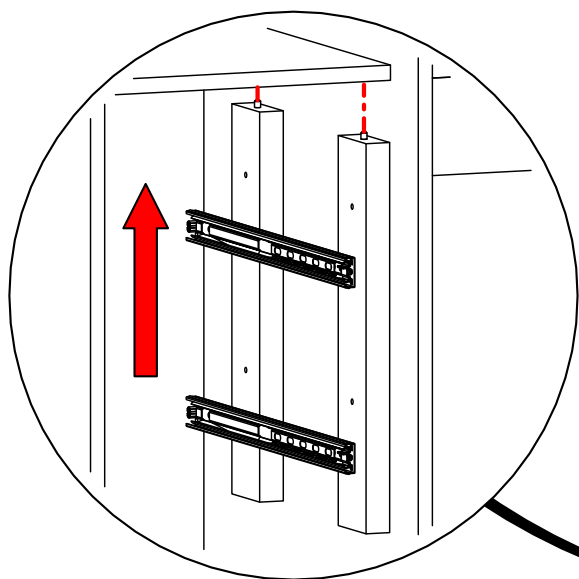

PASSO / PASO / STEP 22

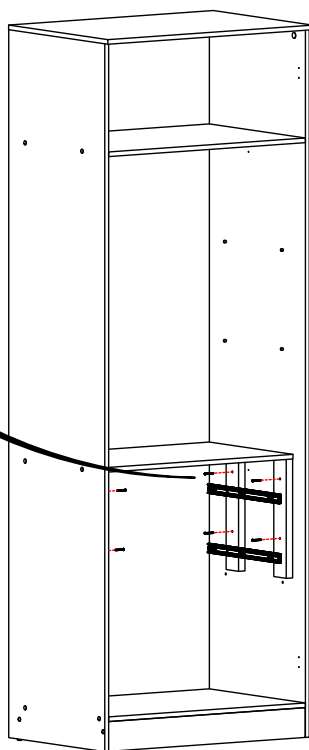
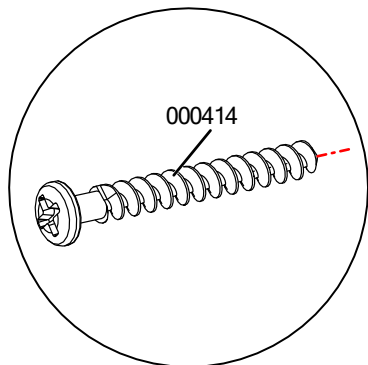
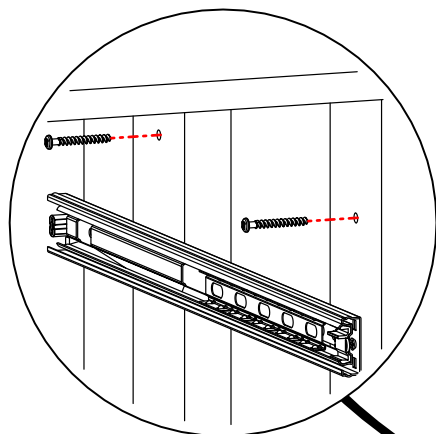

Cod.	Qtde.
000414	8

ARM80AMDP

PASSO / PASO / STEP 23

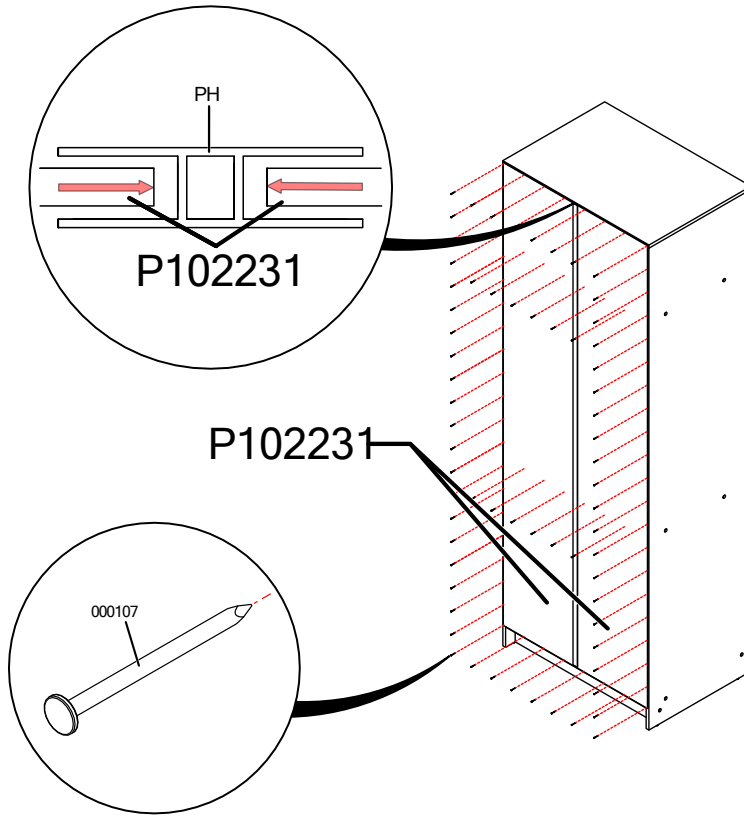

Cod.	Qtde.
PH	1
000107	70

PASSO / PASO / STEP 24

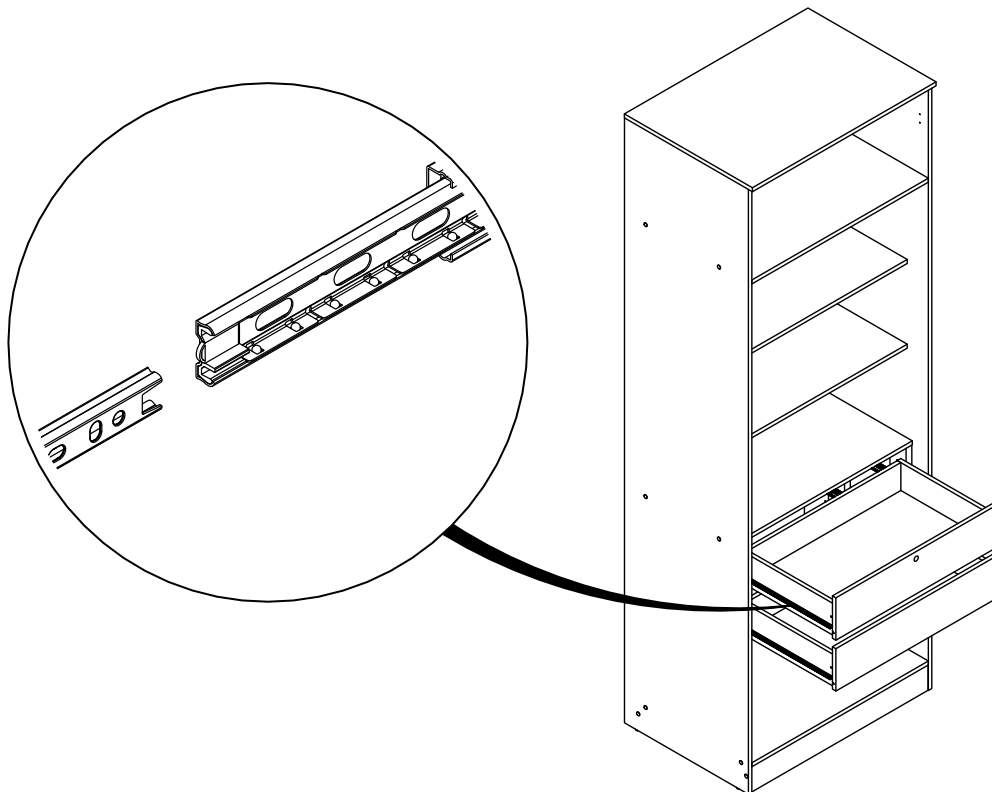

PASSO / PASO / STEP 25

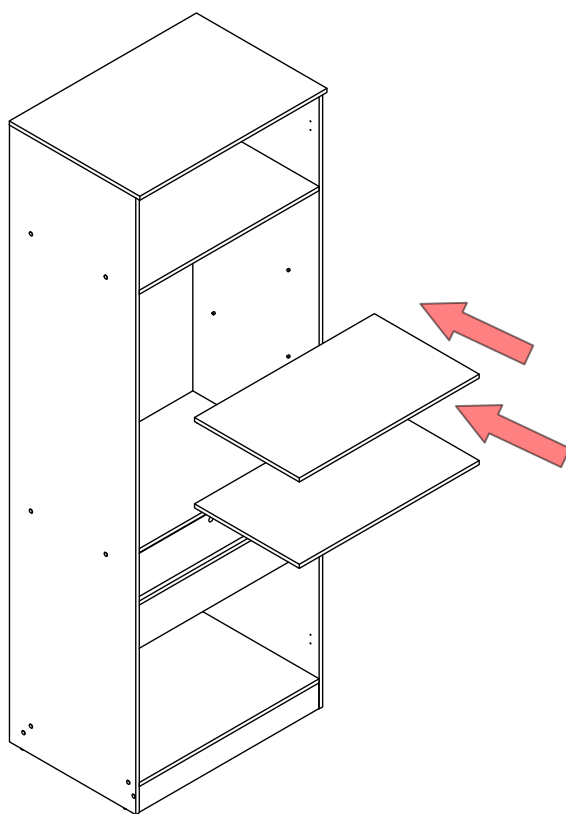

PASSO / PASO / STEP 26

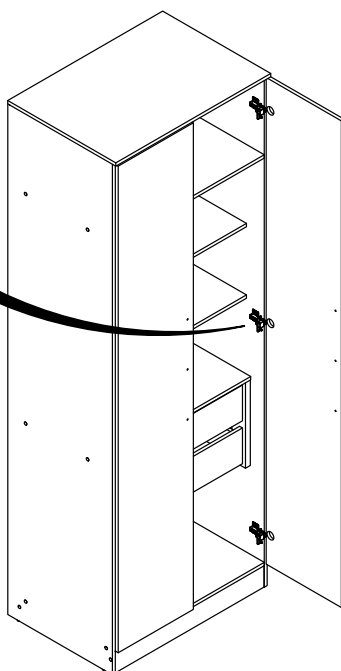
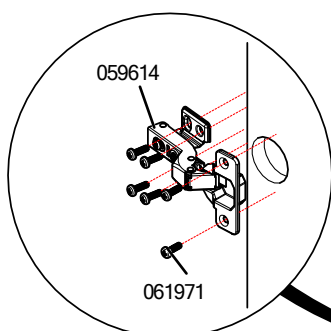

Cod.	Qtde.
061971	36
059614	6

ARM80AMDP