

# Manual de montagem

Instrucciones de montaje Assembly instructions

## ARM71AMDP

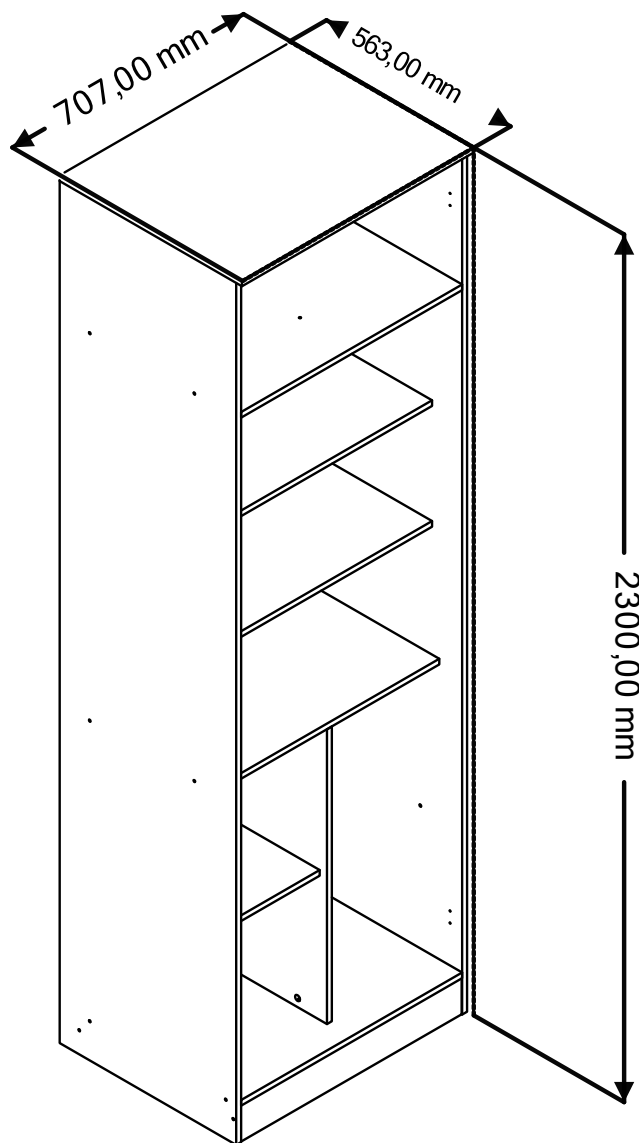

**! Imagens meramente ilustrativas !**  
Imágenes ilustrativas/Images merely illustrative.

Dúvidas? Entre em contato:  
Dudas? Ponerse em contacto:  
Doubts? Get in touch:  
(51) 3635-8839

## A montagem deve ser efetuada por 2 pessoas.

El montaje debe ser efectuada por 2 personas.

The assembly must be done by 2 people.

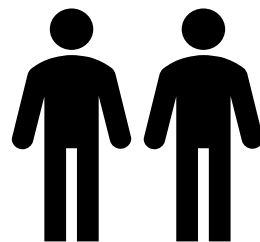

## Ferramentas necessárias para montar o móvel.

Tools needed to assemble the furniture.

Herramientas necesarias para armar el mueble.



## Dúvidas? Entrar em contato:

Dudas? Ponerse en contacto:

Doubts? Get in touch:

Fone: (51) 3635-8839

[www.kappesberg.com.br](http://www.kappesberg.com.br)



## Montar o móvel sobre uma superfície limpa e plana.

Armar el mueble sobre una superficie limpia y plana.

Assemble the furniture on a clean, flat surface.

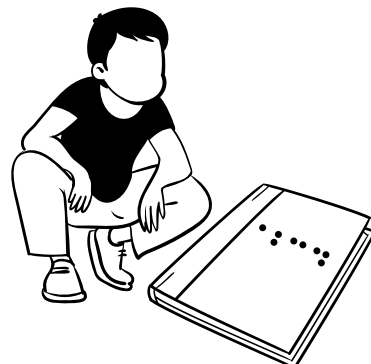

**IDENTIFICAÇÃO DAS PEÇAS / IDENTIFICACIÓN DE LAS PIEZAS PARTS  
IDENTIFICATION**

Quantidade Cantidad Amount	Código Code	Descrição	Descripción	Description	C x L x E	L x W x T
2	P102259	BASE	BASE	BASE	676 x 540 x 15 mm	26.61 x 21.26 x 0.59 in
1	P102190	LATERAL DIREITA	LADO DIRECTO	RIGHT SIDE	2285 x 540 x 15 mm	89.96 x 21.26 x 0.59 in
1	P102251	TAMPO DE GAVETA	TAPA DEL CAJON	TOP OF DRAWERS	676 x 470 x 15 mm	26.61 x 18.50 x 0.59 in
2	P102260	PRATELEIRA	ESTANTE	SHELF	676 x 448 x 15 mm	26.61 x 17.64 x 0.59 in
1	P102258	CHAPÉU	SOMBRERO	HAT	707 x 558 x 15 mm	27.83 x 21.97 x 0.59 in
1	P102209	LATERAL ESQUERDA	LADO IZQUERDA	LEFT SIDE	2285 x 540 x 15 mm	89.96 x 21.26 x 0.59 in
2	P102248	RODAPE	ZOCALO	BASEBOARD	676 x 96 x 15 mm	26.61 x 3.78 x 0.59 in
2	P102261	COSTA	COSTA	COAST	2194 x 345 x 3 mm	86.38 x 13.58 x 0.12 in
1	P102250	DIVISORIA	DIVISION	DIVISION	781 x 470 x 15 mm	30.75 x 18.50 x 0.59 in
1	P102213	PRATELEIRA	ESTANTE	SHELF	332 x 448 x 15 mm	13.07 x 17.64 x 0.59 in

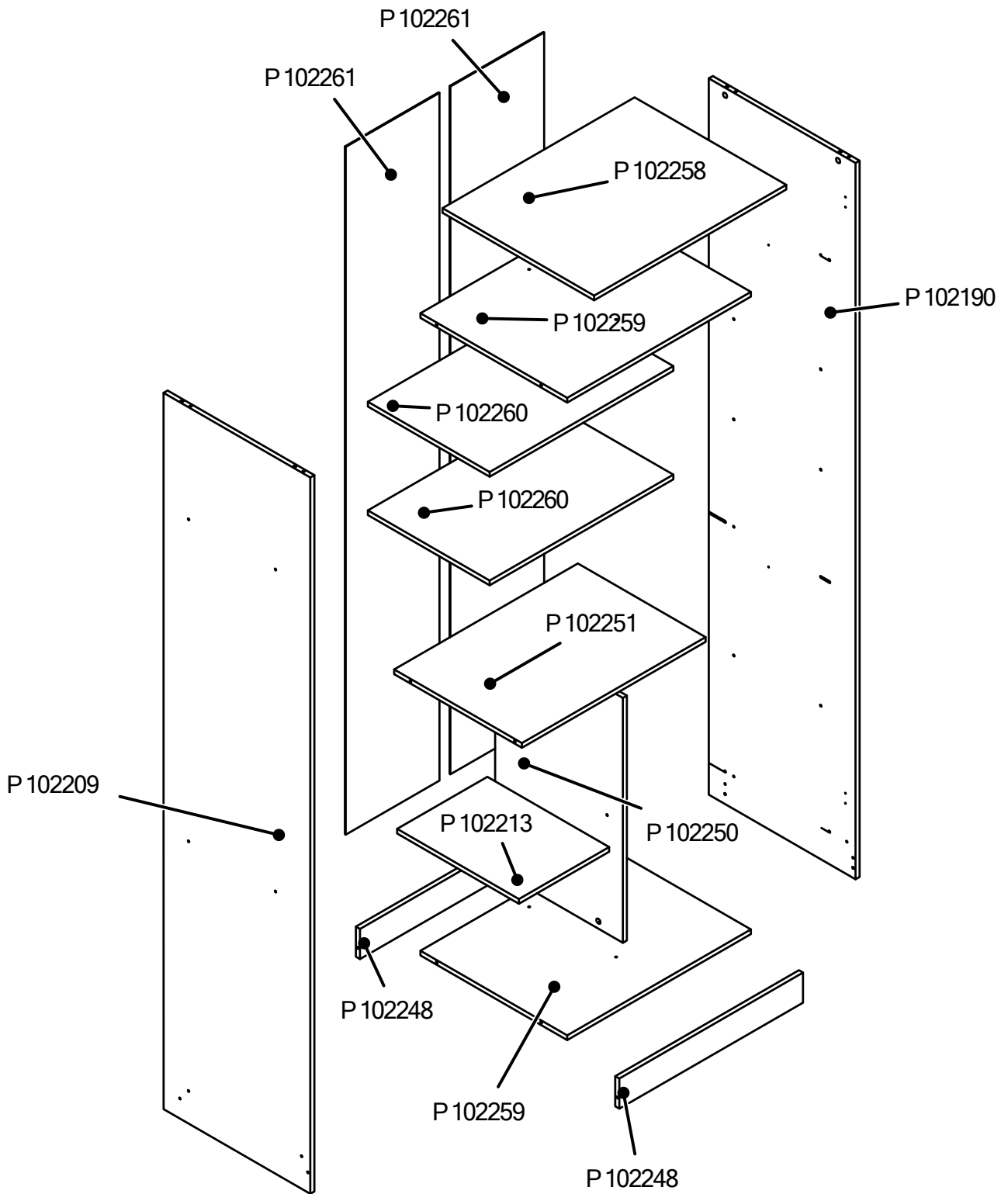







## IDENTIFICAÇÃO DOS ACESSÓRIOS / IDENTIFICACIÓN DE ACCESORIOS IDENTIFICATION OF ACCESSORIES

**NOTAS: A separação dos acessórios antes de iniciar a montagem facilitará a mesma. Em caso de dúvida na identificação, coloque o acessório sobre a régua.**

Nota: Separar los accesorios antes de iniciar el montaje facilitará el mismo. En caso de duda en la identificación, coloque el accesorio en la regla.

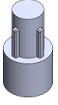
NOTE: Separating the accessories before starting assembly will make it easier. In case of doubt in the identification, place the accessory on the ruler.

	Quantidade e Cantidad Amount	Código / Code	Descrição	Descripción	Description
	8	054117	P.CHATO 3,5 X 25 CAB. PHILLIPS ZB/BC (IDELLI)	TORNILLO 3,5 X 25	SCREW 3,5 X 25
	20	001802	CAVILHAS DE MADEIRA 6X30	TARUGO 6X30MM	DOWEL 6X30MM
	16	000226	P.CHATO 4,0 X 40MM	TORNILLO 4,0 X 40MM	SCREW 4,0 X 40MM
	8	030950	TAMBOR P/ MINIFIX 15MM ZAMAQ	CILINDRO 15MM	BARREL 15MM
	8	030945	PARAFUSO DE ACO P/ MINIFIX	TORNILLO DE ACERO PARA MINIFIX	STEEL SCREW FOR MINIFIX
	12	000118	SUP. P/ PRAT. 6 X 8MM	SOPORTE DE ESTANTE 6 X 8	SHELF SUPPORT 6 X 8
	16	13MM	TAPA FURO 13MM	TAPA DEL AGUJERO 13MM	SCREW CAP COVER 13MM

## IDENTIFICAÇÃO DOS ACESSÓRIOS / IDENTIFICACIÓN DE ACCESORIOS IDENTIFICATION OF ACCESSORIES

	8	19MM	TAPA FURO 19MM	TAPA DEL AGUJERO 19MM	SCREW CAP COVER 19MM
	36	061971	P.PANELA 4,0 X 14 ZB P/DOBRADICA	TORNILLO 4,0 X 14	SCREW 4,0 X 14
	6	059614	DOBRAD. CURVA 35MM C/ CALCO FIXO E AMORTECEDOR	BISAGRA DE CALCE	HINGE AND SHIM
	4	001901	SAPATA DESLIZADORA PRETA	ZAPATO 15 X 6	SHOE 15 X 6
	4	000108	PREGO 12 X 12	CLAVO 12 X 12	NAIL 12 X 12
	71	000107	PREGO 10 X 10	CLAVO 10 X 10	NAIL 10 X 10
	12	004214	P.CHATO 3,5 X 14	TORNILLO 3,5 X 14MM	SCREW 3,5 X 14MM
	2	000899	CANTONEIRA PLASTICA PRETA	CANTONERA	PLASTIC HANDLE
	2	041921	SUP. P/ CABIDEIRO OBLONGO	SOPORTE PERCHA	CLOTHES RACK
	1	076866	ROLICO OBLONGO 15X25MM ALUMINIO NATURAL FRISADO	PERCHA	RACK
	1	PH	PERF. H26	PERFIL H	PROFILE H

## INSTALAÇÃO MINIFIX

Identificar seta no corpo do tambor de minifix. A seta DEVE apontar para o buraco na borda do painel. Empurrar o tambor até o buraco.

## INSTALACIÓN DE LA LEVA

Identifique la flecha en los muertos de la leva. La flecha debe apuntar hacia el agujero en el borde del panel. Empuje la leva hasta el fondo del orificio.

## INSTALLING CAM

Identify arrow on head of cam. Arrow MUST point toward hole in edge of panel. Push cam all the way down into hole.

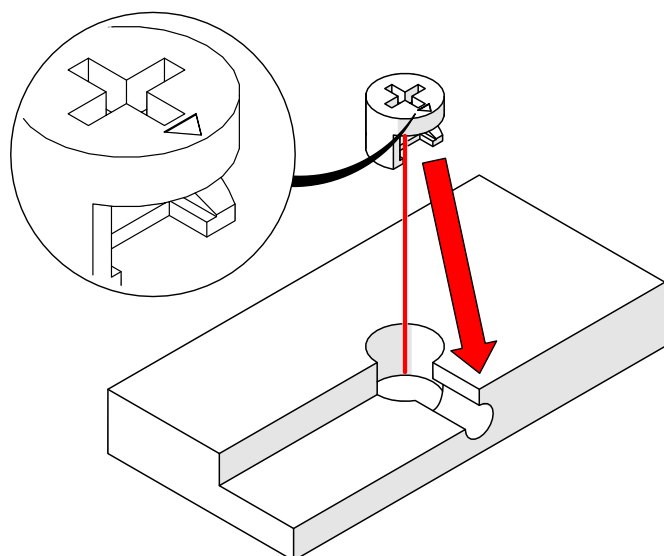

## ALINHAMENTO DO TAMBOR E PARAFUSO

A seta do tambor de minifix deve ser aponta para o buraco e inserir o parafuso do minifix do tambor contido no buraco. Certifique-se de que as peças se unam.

## ALINEACIÓN DE LA LEVA Y EL PASADOR

Asegúrese de que la flecha de la leva apunte hacia el orificio e inserte la clavija de la leva en el orificio. Asegúrese de que las piezas se unen.

## CAM AND DOWEL ALIGNMENT

Ensure the arrow on the cam points toward hole and insert cam dowel into hole. Make sure pieces join together.

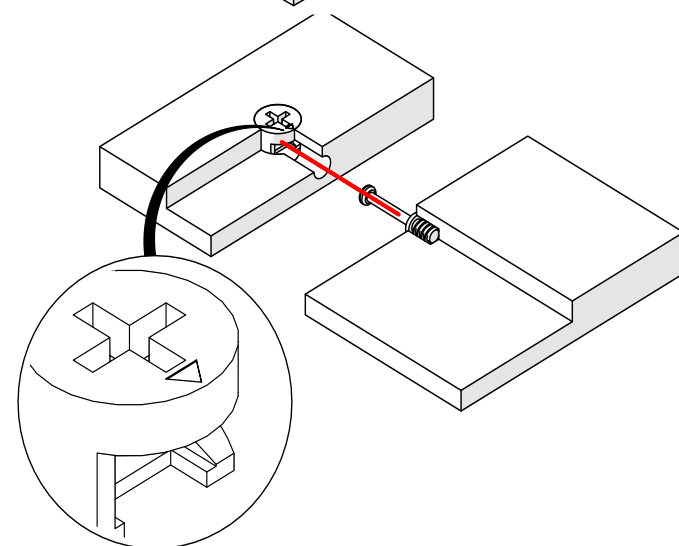

## CÂMARA DE COMPENSAÇÃO DE TENSÃO

Use uma chave de fenda para girar a came. Girar o tambor minifix (no sentido horário) até que esteja totalmente apertado. Ligeiramente mais de meia volta.

## APRIETE DE LA LEVA

Utilice un destornillador para girar la leva. Gire la leva (en el sentido de las agujas del reloj) hasta que esté completamente apretada. Un poco más de media vuelta.

## TIGHTENING CAM

Use screwdriver to turn cam. Turn cam (clockwise) until fully tightened. Slightly more than half a turn.

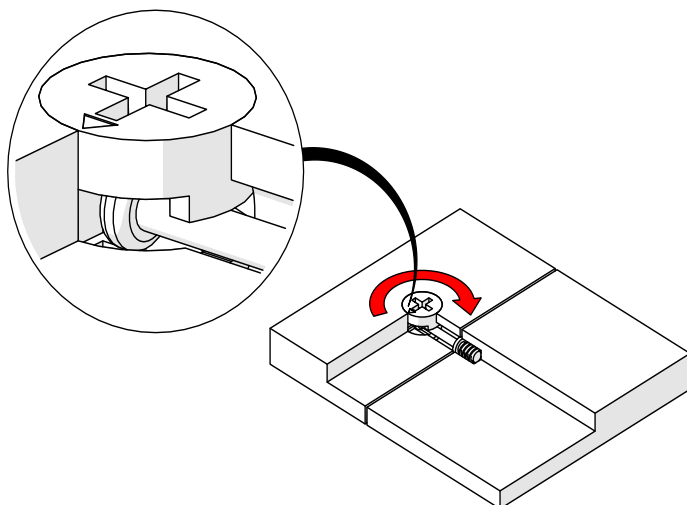

## PASSO / PASO / STEP 1

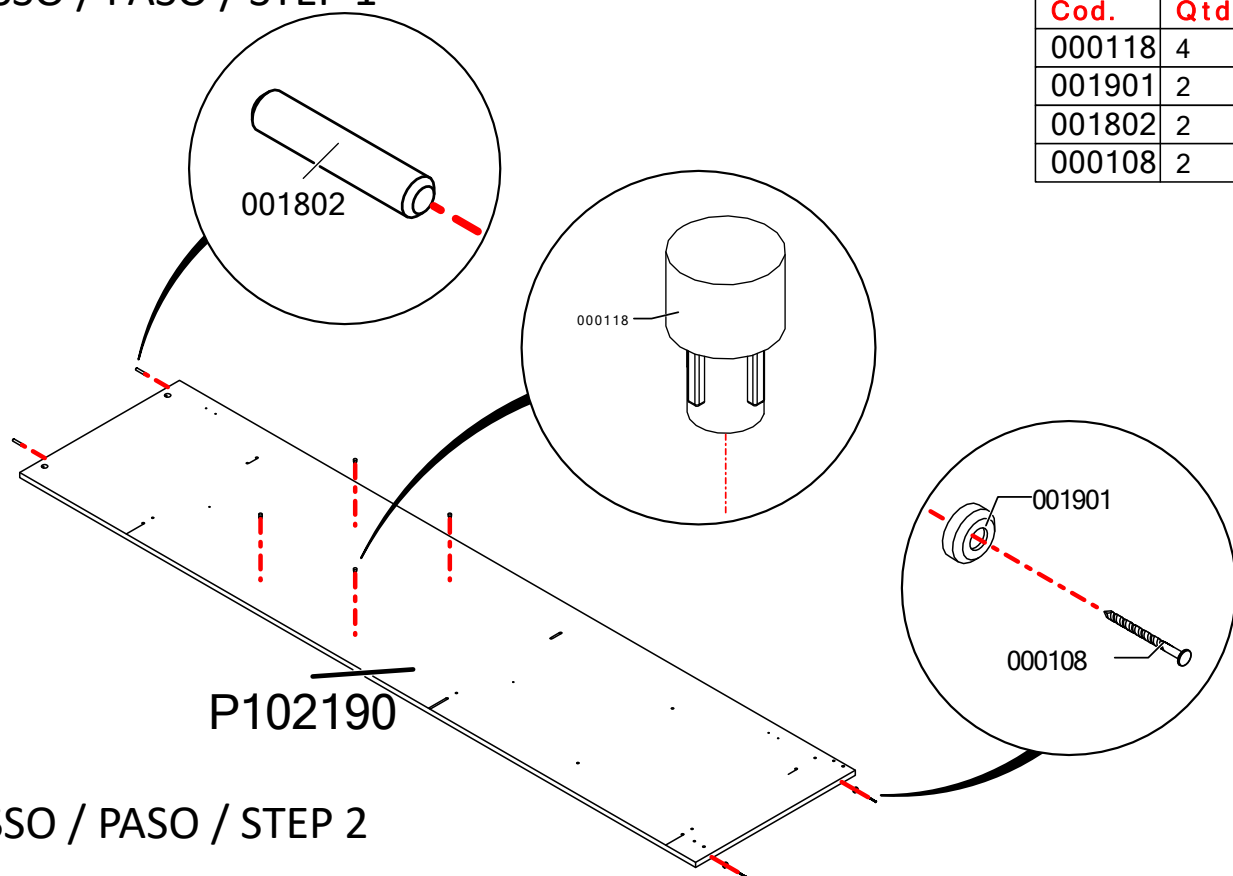

Cod.	Qtde.
000118	4
001901	2
001802	2
000108	2

## PASSO / PASO / STEP 2

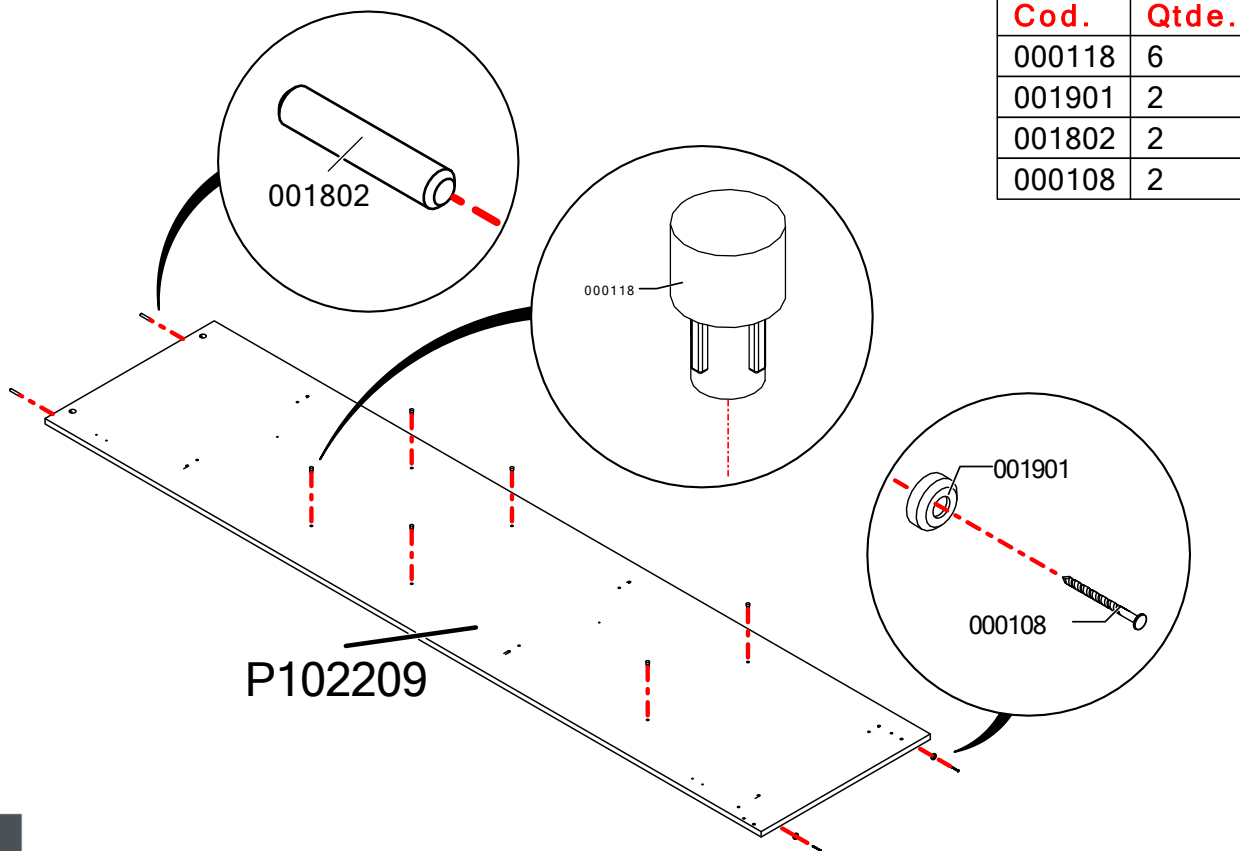

Cod.	Qtde.
000118	6
001901	2
001802	2
000108	2

ARM71AMDP



Cod.	Qtde.
001802	2

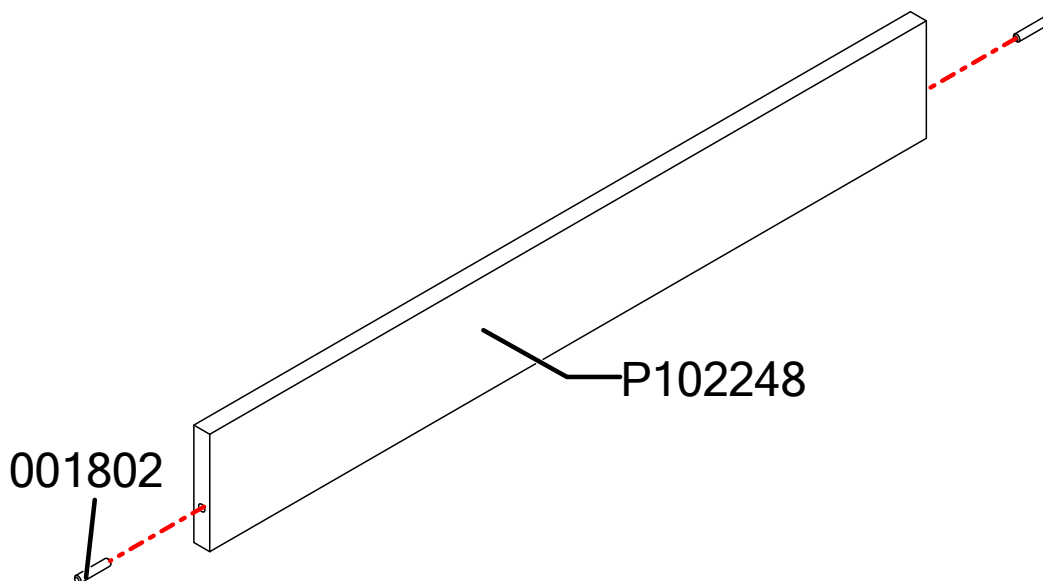

PASSO / PASO / STEP 4

Cod.	Qtde.
004214	2
000118	2
041921	1

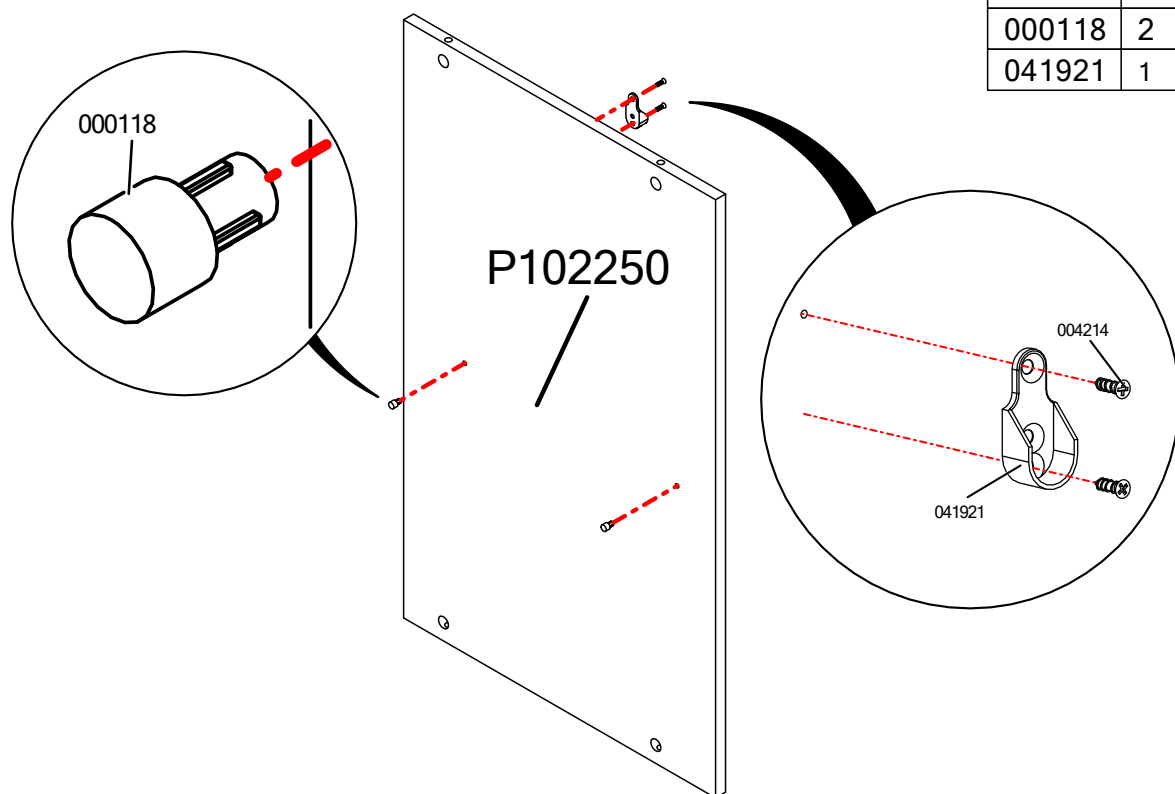

## PASSO / PASO / STEP 5

Cod.	Qtde.
001802	4
030945	2

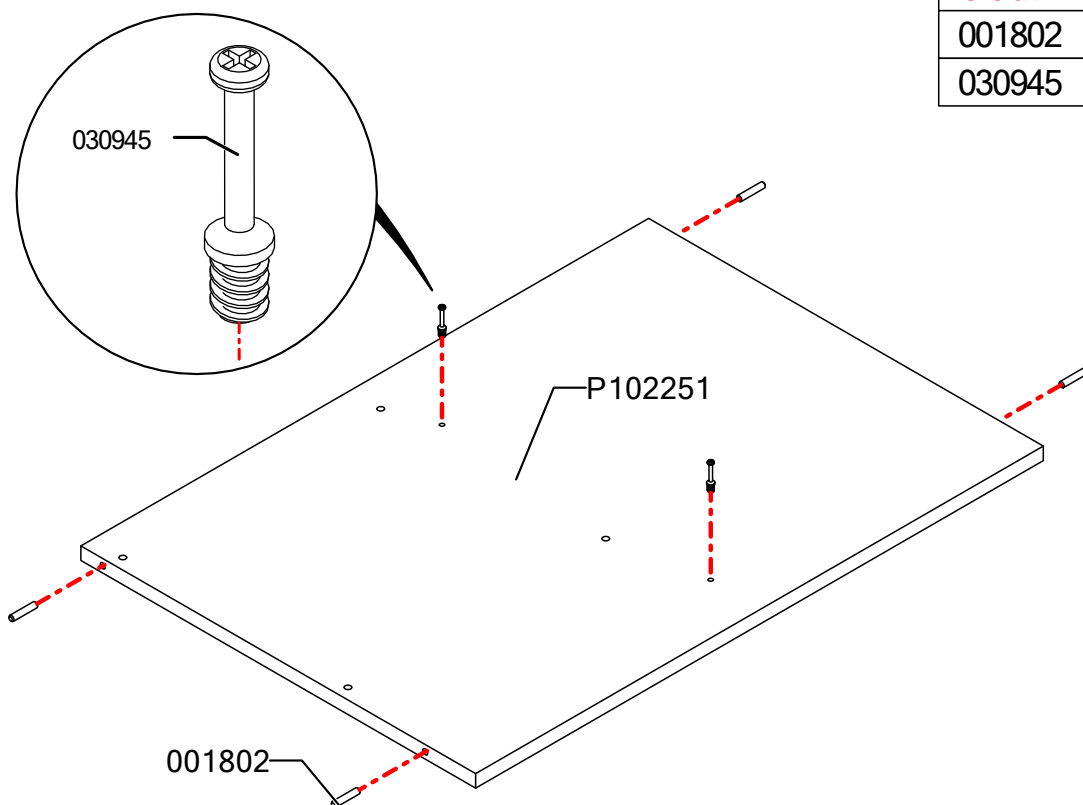

## PASSO / PASO / STEP 6

Cod.	Qtde.
030945	4

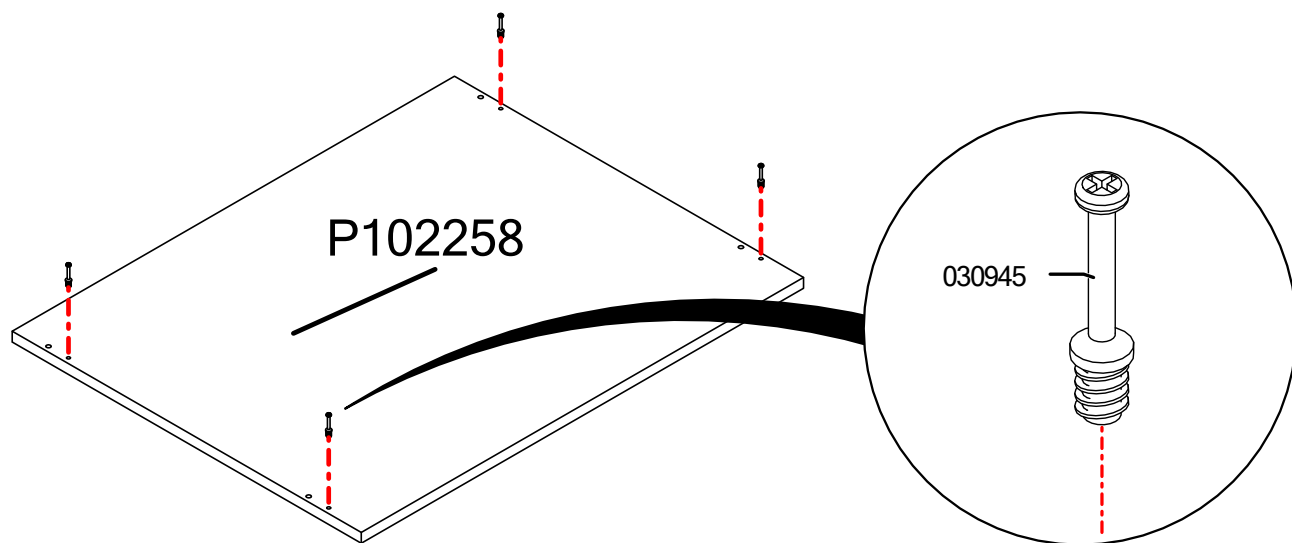

Cod.	Qtde.
001802	4

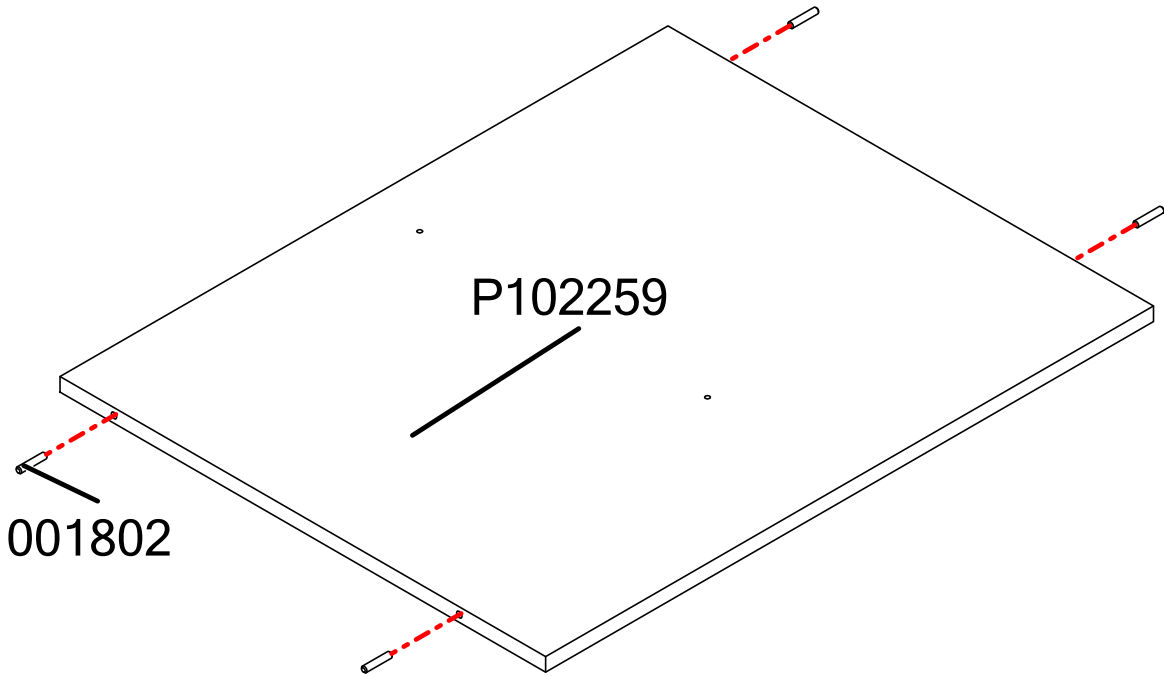

PASSO / PASO / STEP 8

Cod.	Qtde.
001802	4
030945	2

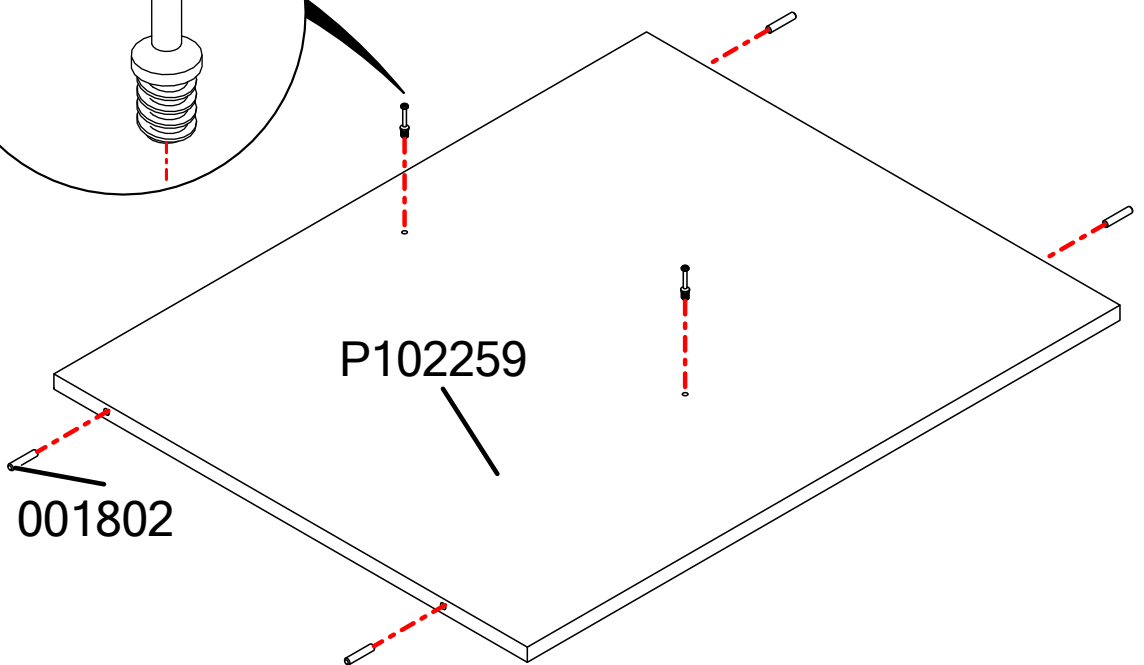
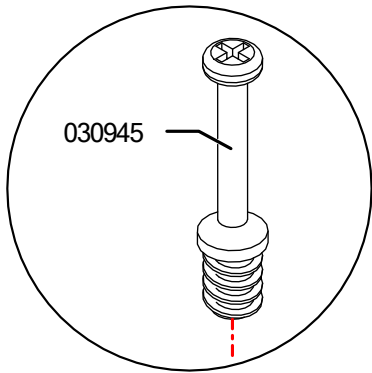

## PASSO / PASO / STEP 9

Cod.	Qtde.
19MM	4
030950	4

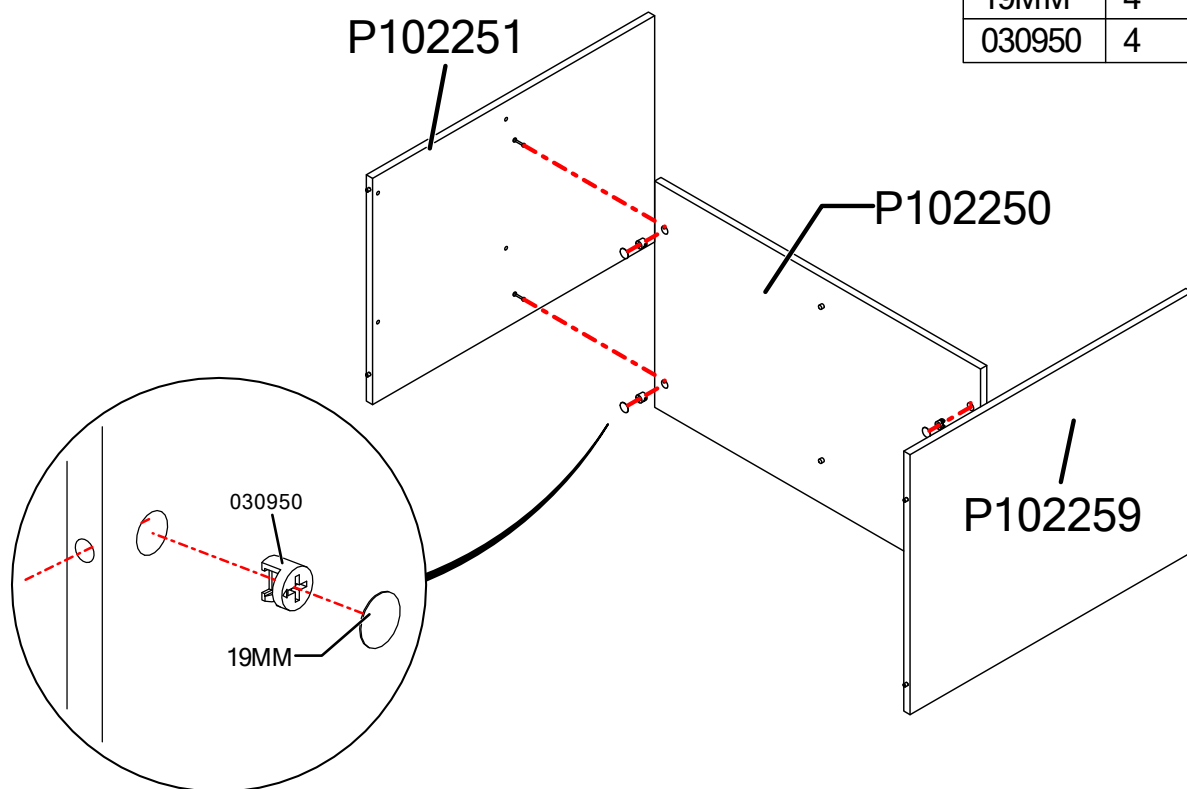

## PASSO / PASO / STEP 10

Cod.	Qtde.
13MM	16
000226	16
004214	8
000899	2

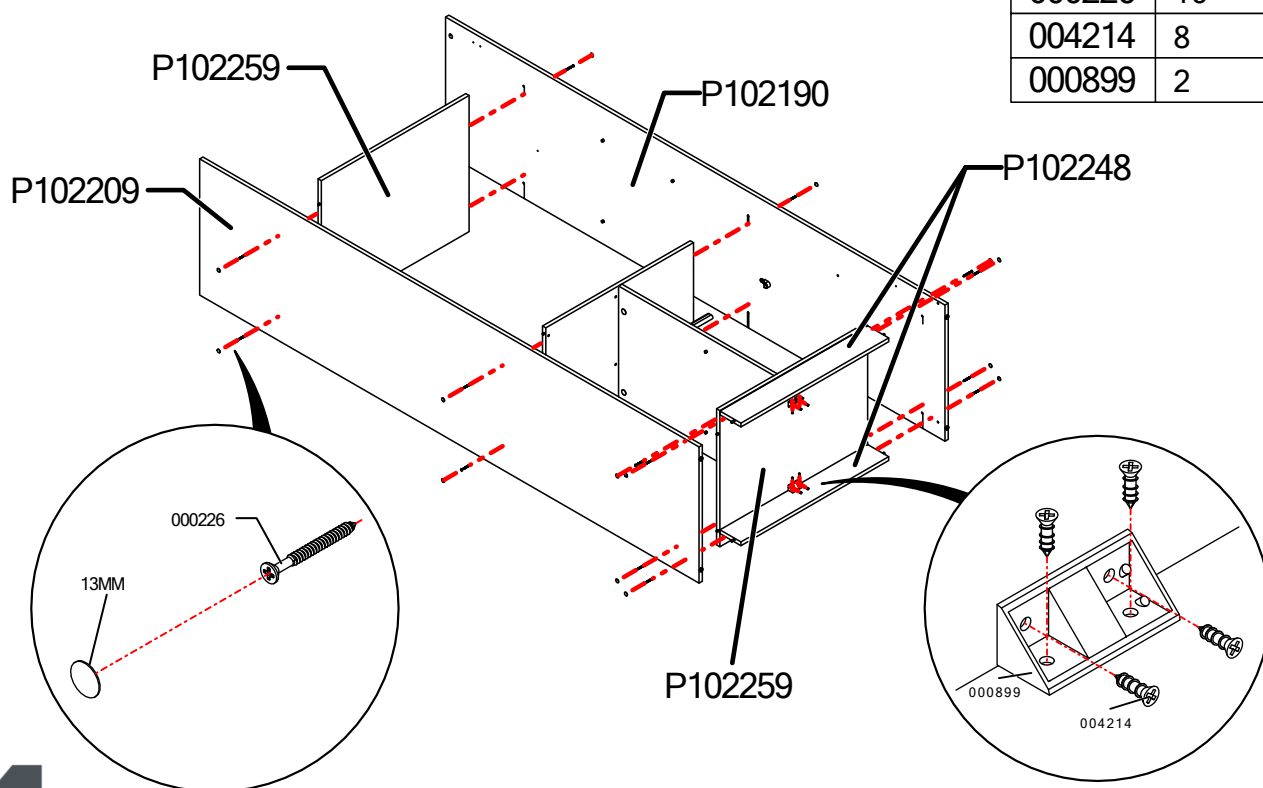

## PASSO / PASO / STEP 11

Cod.	Qtde.
19MM	4
<b>030950</b>	<b>4</b>

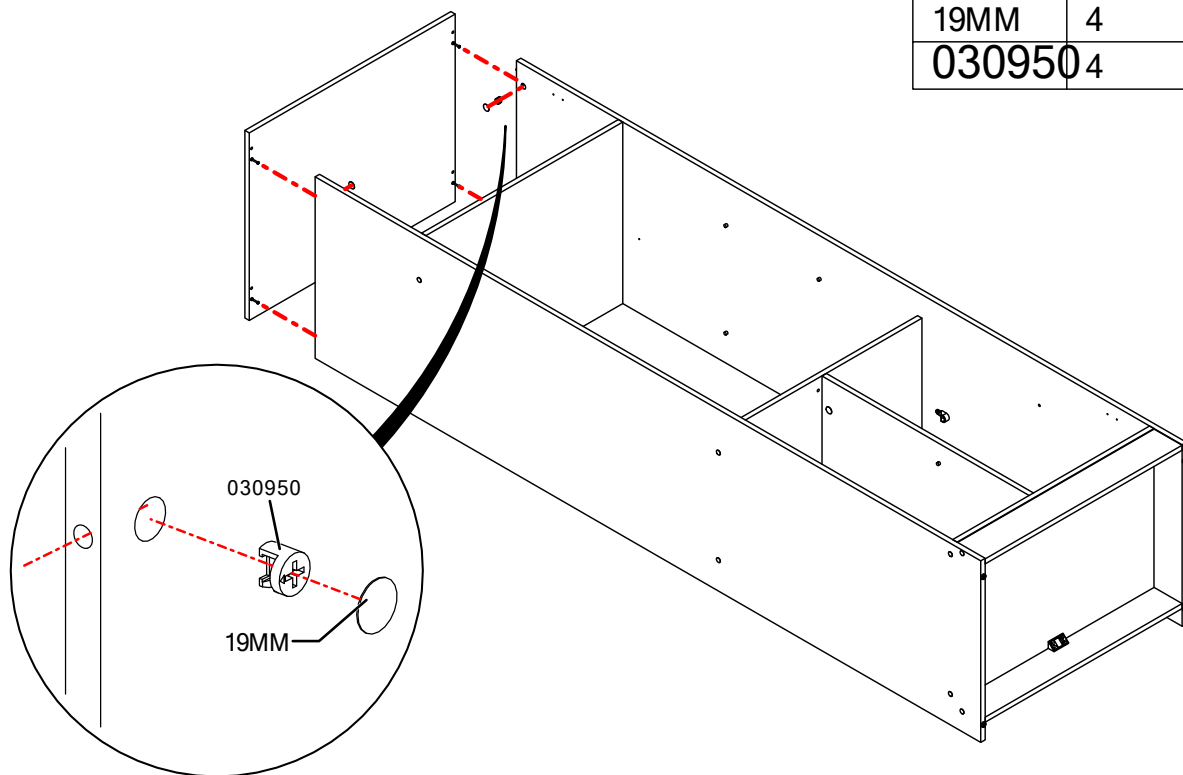

## PASSO / PASO / STEP 12

Cod.	Qtde.
000107	71
PH	1

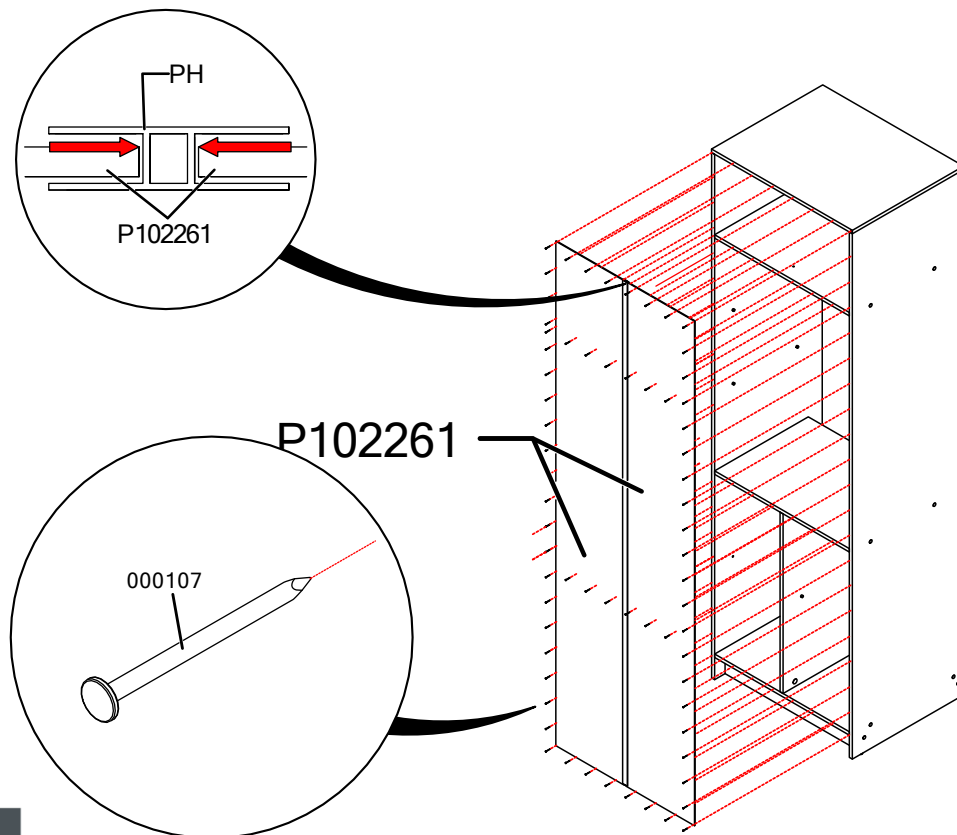

ARM71AMDP

## PASSO / PASO / STEP 13

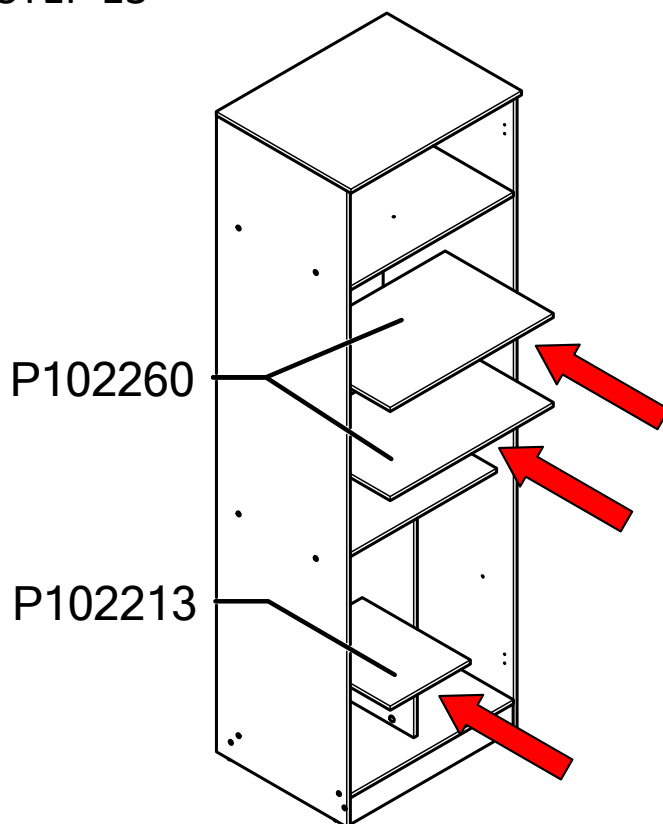

## PASSO / PASO / STEP 14

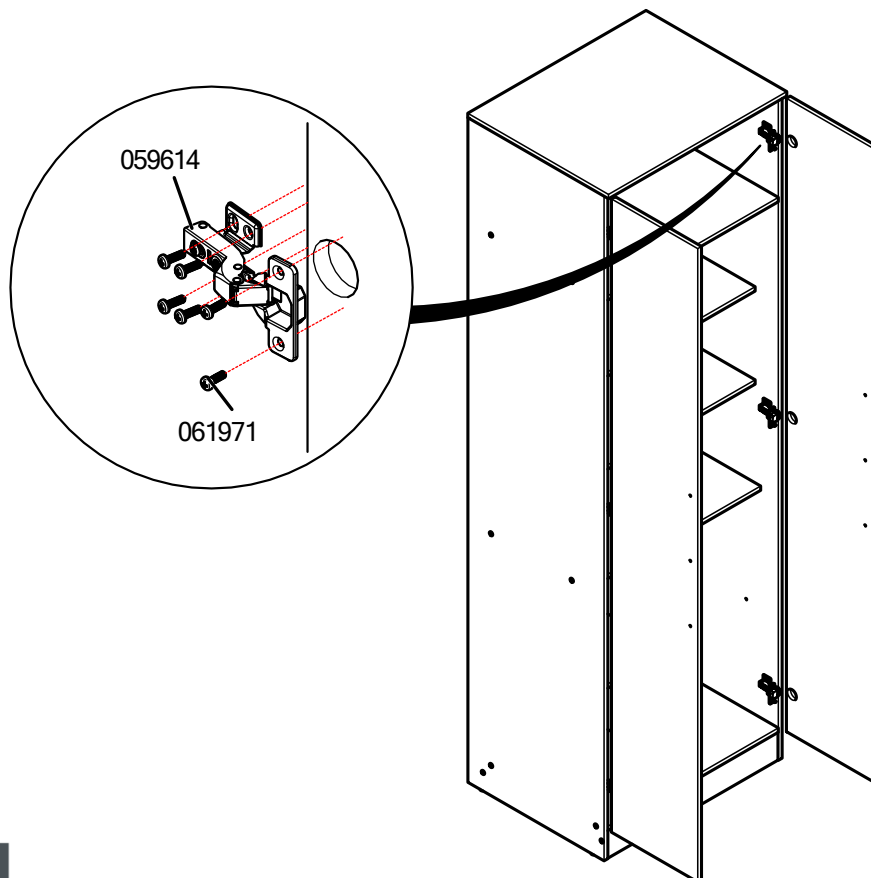

Cod.	Qtde.
061971	36
059614	6

ARM71AMDP

Cod.	Qtde.
076866	1

