

Manual de montagem

Instrucciones de montaje Assembly instructions

ARM36AMDP

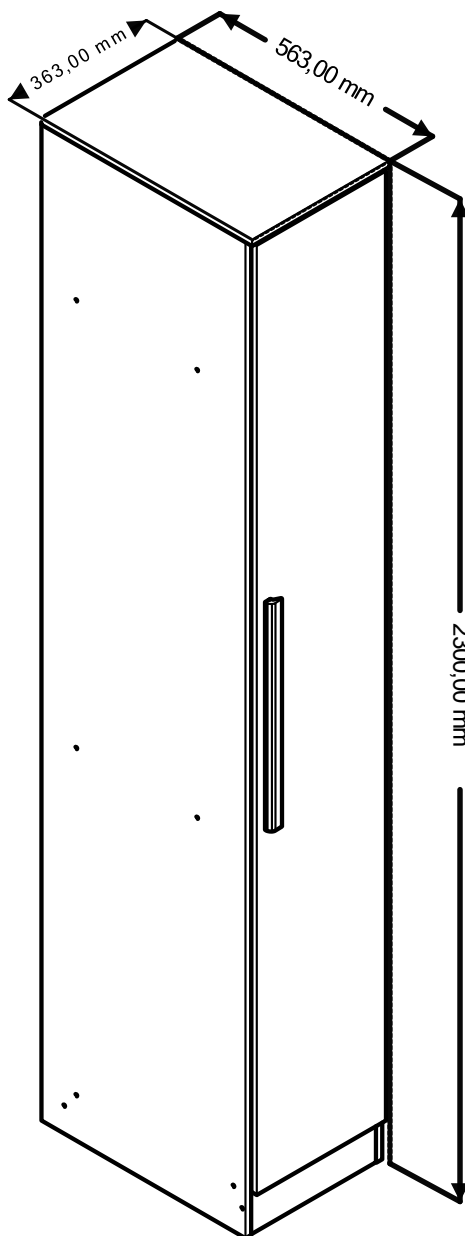

! Imagens meramente ilustrativas !
Imágenes ilustrativas/Images merely illustrative.

Dúvidas? Entre em contato:
Dudas? Ponerse em contacto:
Doubts? Get in touch:
(51) 3635-8839

A montagem deve ser efetuada por 2 pessoas.

El montaje debe ser efectuada por 2 personas.

The assembly must be done by 2 people.

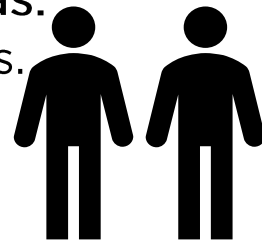

Ferramentas necessárias para montar o móvel.

Herramientas necesarias para armar el mueble.

Tools needed to assemble the furniture.



Dúvidas? Entrar em contato:

Dudas? Ponerse en
contacto:

Doubts? Get in touch:

Fone: (51) 3635-8839

www.kappesberg.com.br



Montar o móvel sobre uma superfície limpa e plana.

Armar el mueble sobre una superficie limpia y plana.

Assemble the furniture on a clean, flat surface.

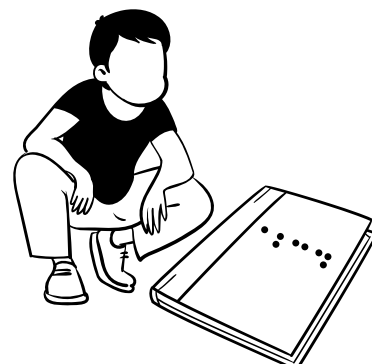

**IDENTIFICAÇÃO DAS PEÇAS / IDENTIFICACIÓN DE LAS PIEZAS
PARTS IDENTIFICATION**

Quantidade Cantidad Amount	Código Code	Descrição	Descripción	Description	C x L x E	L x W x T
1	P102190	LATERAL DIREITA	LADO DIRECTO	RIGHT SIDE	2285 x 540 x 15 mm	89.96 x 21.26 x 0.59 in
2	P102212	BASE	BASE	BASE	332 x 540 x 15 mm	13.07 x 21.26 x 0.59 in
3	P102213	PRATELEIRA	ESTANTE	SHELF	332 x 448 x 15 mm	13.07 x 17.64 x 0.59 in
1	P102216	TAMPO DE GAVETA	TAPA DEL CAJON	TOP OF DRAWERS	332 x 470 x 15 mm	13.07 x 18.50 x 0.59 in
1	P102211	CHAPÉU	SOMBRERO	HAT	363 x 558 x 15 mm	14.29 x 21.97 x 0.59 in
1	P102209	LATERAL ESQUERDA	LADO IZQUERDA	LEFT SIDE	2285 x 540 x 15 mm	89.96 x 21.26 x 0.59 in
2	P102215	RODAPE	ZOCALO	BASEBOARD	332 x 96 x 15 mm	13.07 x 3.78 x 0.59 in
1	P102214	COSTA	COSTA	COAST	2194 x 352 x 3 mm	86.38 x 13.86 x 0.12 in

IDENTIFICAÇÃO DAS PEÇAS / IDENTIFICACIÓN DE LAS PIEZAS PARTS IDENTIFICATION

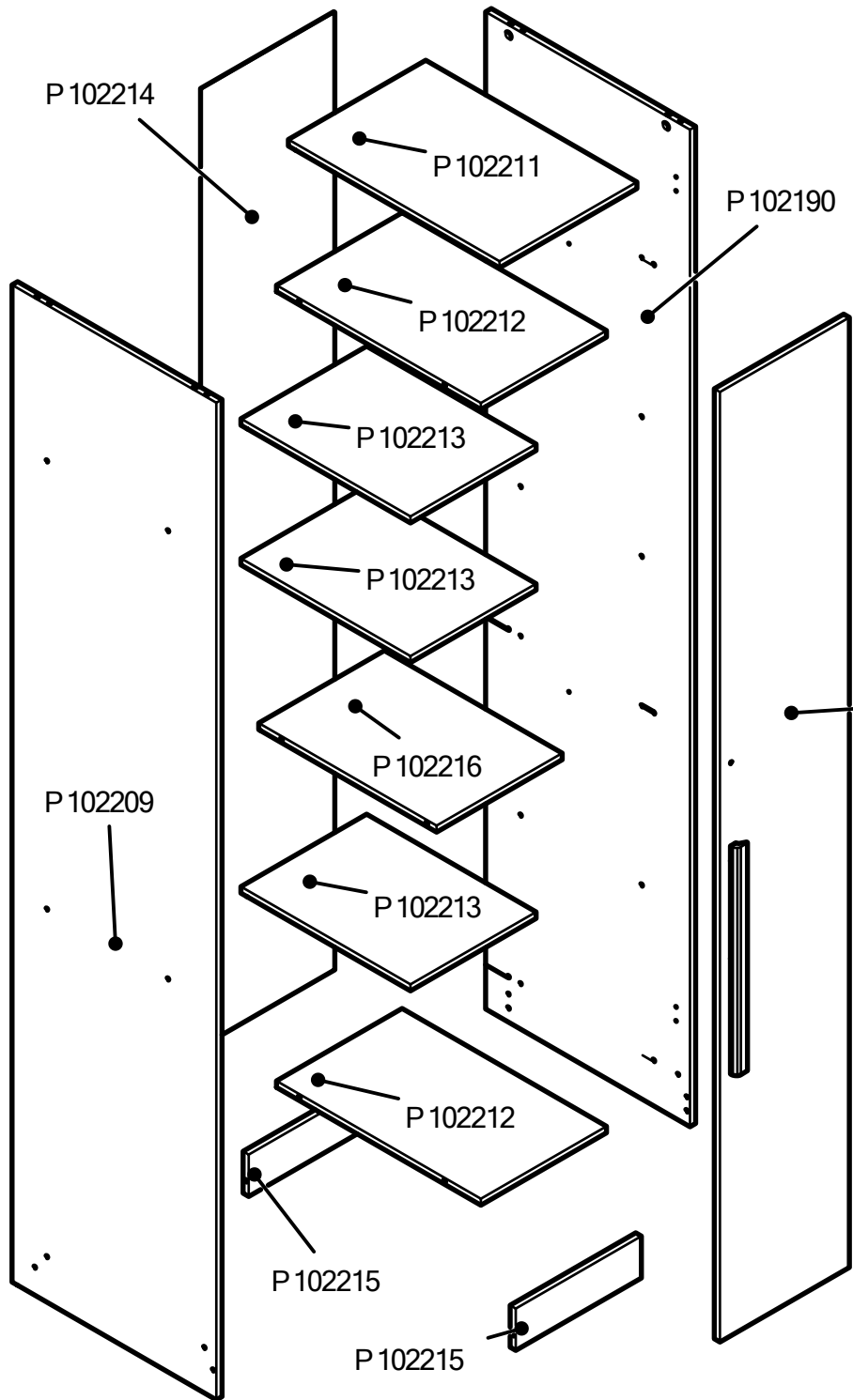









IDENTIFICAÇÃO DOS ACESSÓRIOS / IDENTIFICACIÓN DE ACCESORIOS IDENTIFICATION OF ACCESSORIES







NOTAS: A separação dos acessórios antes de iniciar a montagem facilitará a mesma. Em caso de dúvida na identificação, coloque o acessório sobre a régua.

Nota: Separar los accesorios antes de iniciar el montaje facilitará el mismo. En caso de duda en la identificación, coloque el accesorio en la regla.

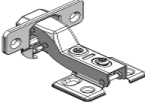
NOTE: Separating the accessories before starting assembly will make it easier. In case of doubt in the identification, place the accessory on the ruler.

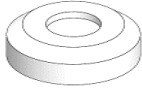
	Quantidade Cantidad Amount	Código Code	Descrição	Descripción	Description
	20	001802	CAVILHAS DE MADEIRA 6X30 PINUS	TARUGO 6X30MM	DOWEL 6X30MM
	16	000226	P.CHATO 4,0 X 40MM	TORNILLO 4,0 X 40MM	SCREW 4,0 X 40MM
	4	030950	TAMBOR P/ MINIFIX 15MM ZAMAQ	CILINDRO 15MM	BARREL 15MM
	4	030945	PARAFUSO DE ACO P/ MINIFIX	TORNILLO DE ACERO PARA MINIFIX	STEEL SCREW FOR MINIFIX
	12	000118	SUP. P/ PRAT. 6 X 8MM BEGE	SOPORTE DE ESTANTE 6 X 8	SHELF SUPPORT 6 X 8
	16	13MM	TAPA FURO 13MM	TAPA DEL AGUJERO 13MM	SCREW CAP COVER 13MM
	4	19MM	TAPA FURO 19MM	TAPA DEL AGUJERO 19MM	SCREW CAP COVER 19MM
	53	000107	PREGO 10 X 10	CLAVO 10 X 10	NAIL 10 X 10

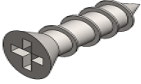
IDENTIFICAÇÃO DOS ACESSÓRIOS / IDENTIFICACIÓN DE ACCESORIOS IDENTIFICATION OF ACCESSORIES

	18	061971	P.PANELA 4,0 X 14 ZB P/DOBRADICA	TORNILLO 4,0 X 14	SCREW 4,0 X 14
	3	059614	DOBRAD. CURVA 35MM C/ CALCO FIXO E AMORTECEDOR	BISAGRA DE CALCE	HINGE AND SHIM
	8	054117	P.CHATO 3,5 X 25	TORNILLO 3,5 X 25	SCREW 3,5 X 25
	4	001901	SAPATA DESLIZADORA PRETA 15 X 6	ZAPATO 15 X 6	SHOE 15 X 6
	4	000108	PREGO 12 X 12	CLAVO 12 X 12	NAIL 12 X 12
	8	004214	P.CHATO 3,5 X 14	TORNILLO 3,5 X 14MM	SCREW 3,5 X 14MM
	2	000899	CANTONEIRA PLASTICA PRETA	CANTONERA	PLASTIC HANDLE

INSTALAÇÃO MINIFIX

Identificar seta no corpo do tambor de minifix. A seta DEVE apontar para o buraco na borda do painel. Empurrar o tambor até o buraco.

INSTALACIÓN DE LA LEVA

Identifique la flecha en los muertos de la leva. La flecha debe apuntar hacia el agujero en el borde del panel. Empuje la leva hasta el fondo del orificio.

INSTALLING CAM

Identify arrow on head of cam. Arrow MUST point toward hole in edge of panel. Push cam all the way down into hole.

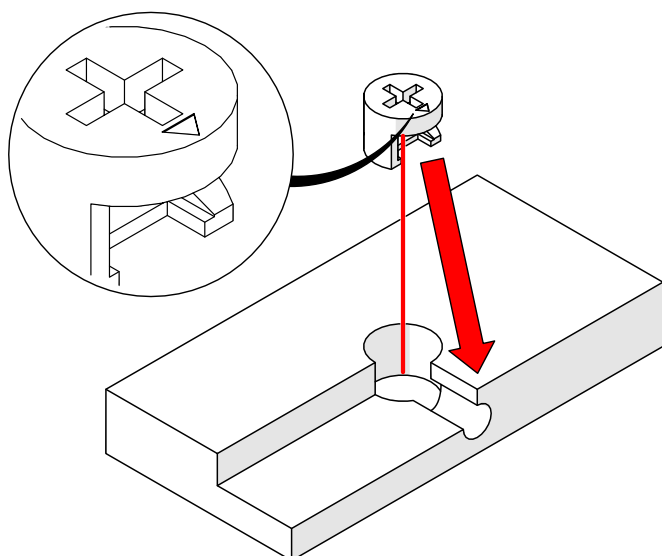

ALINHAMENTO DO TAMBOR E PARAFUSO

A seta do tambor de minifix deve ser apontada para o buraco e inserir o parafuso do minifix do tambor contido no buraco. Certifique-se de que as peças se unam.

ALINEACIÓN DE LA LEVA Y EL PASADOR

Asegúrese de que la flecha de la leva apunte hacia el orificio e inserte la clavija de la leva en el orificio. Asegúrese de que las piezas se unen.

CAM AND DOWEL ALIGNMENT

Ensure the arrow on the cam points toward hole and insert cam dowel into hole. Make sure pieces join together.

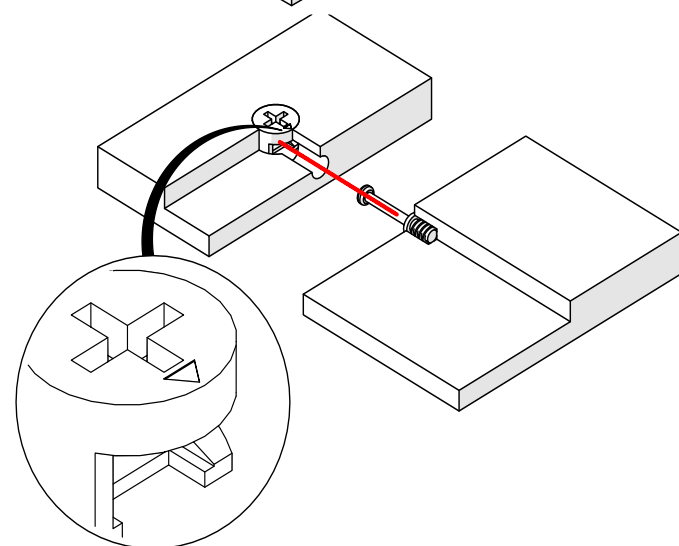

CÂMARA DE COMPENSAÇÃO DE TENSÃO

Use uma chave de fenda para girar a came. Girar o tambor minifix (no sentido horário) até que esteja totalmente apertado. Ligeiramente mais de meia volta.

APRIETE DE LA LEVA

Utilice un destornillador para girar la leva. Gire la leva (en el sentido de las agujas del reloj) hasta que esté completamente apretada. Un poco más de media vuelta.

TIGHTENING CAM

Use screwdriver to turn cam. Turn cam (clockwise) until fully tightened. Slightly more than half a turn.

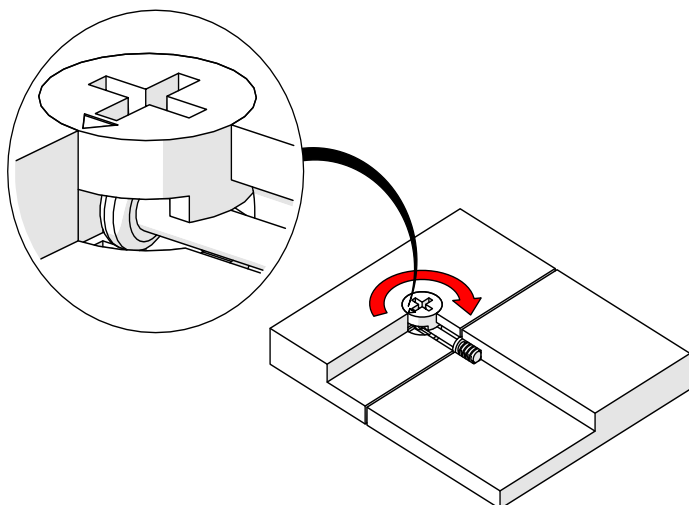

PASSO / PASO / STEP 1

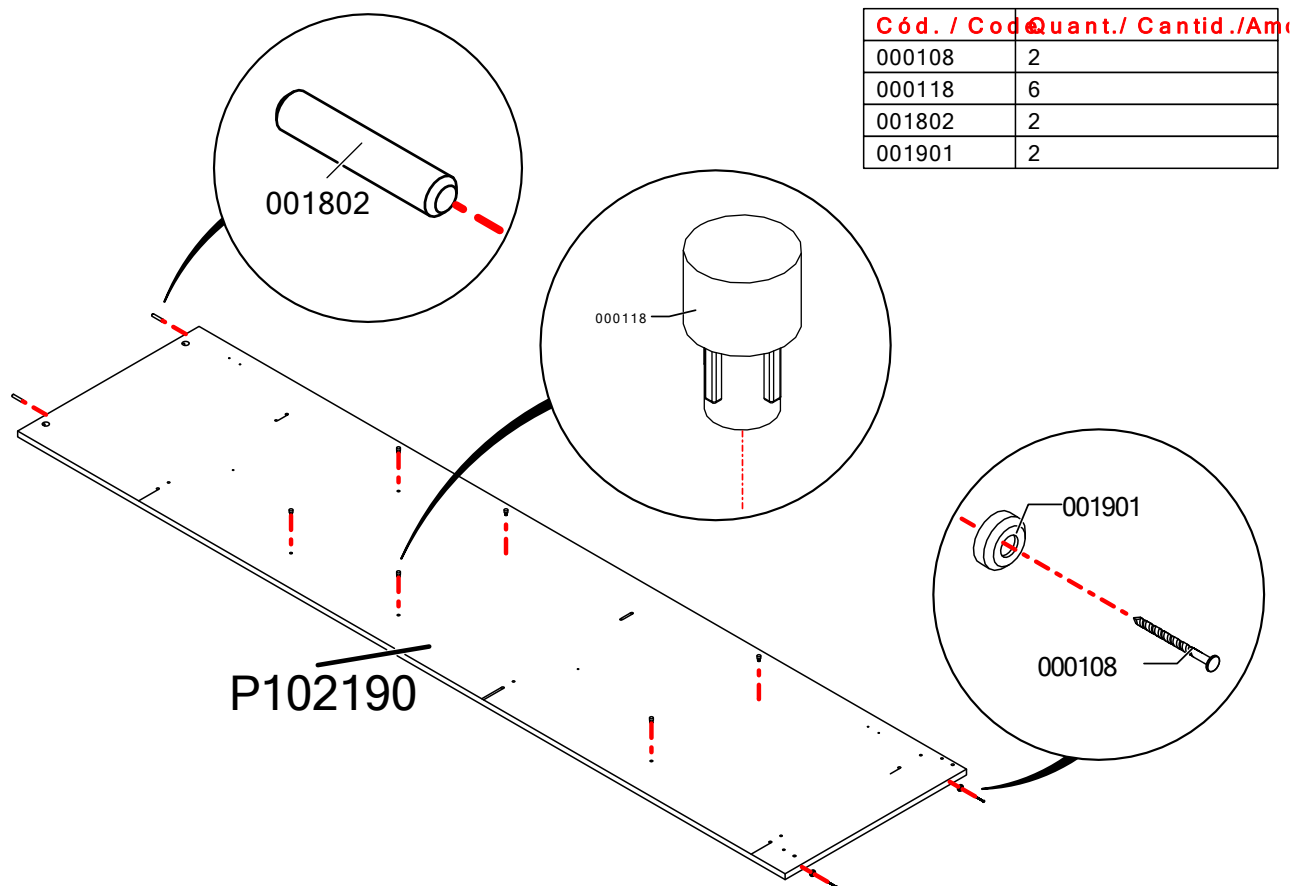

PASSO / PASO / STEP 2

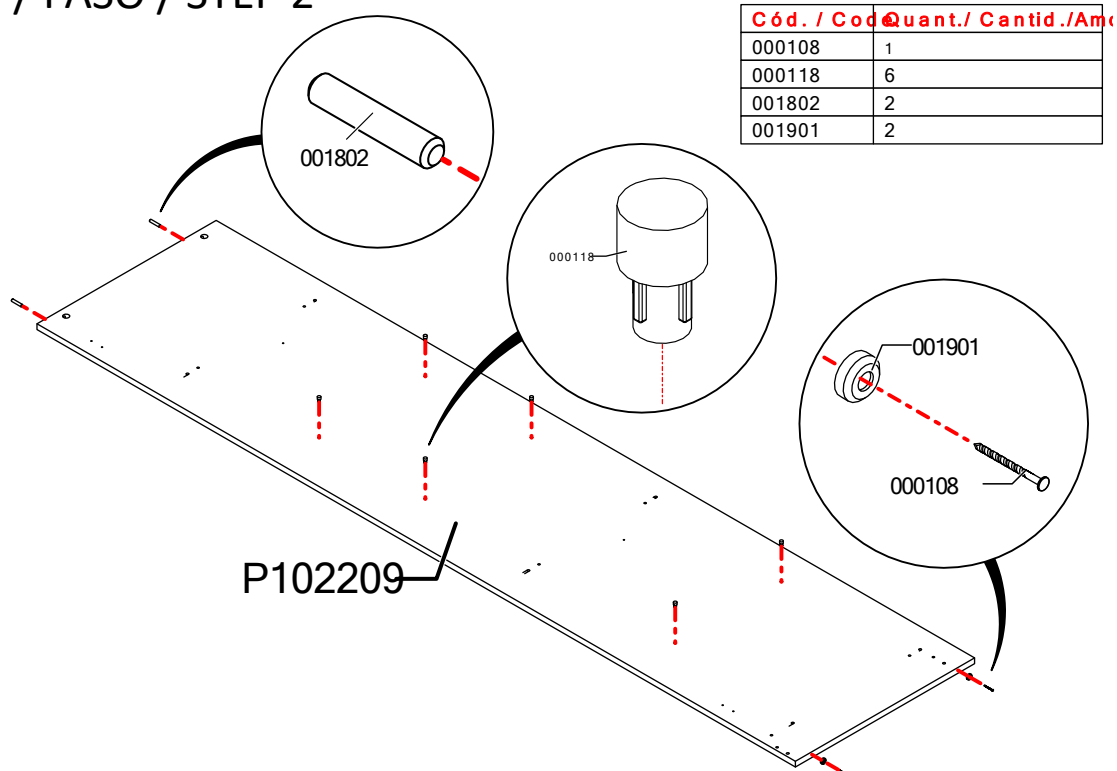

PASSO / PASO / STEP 3

Cód. / Cod	Quant. / Cantid. / A
030945	4

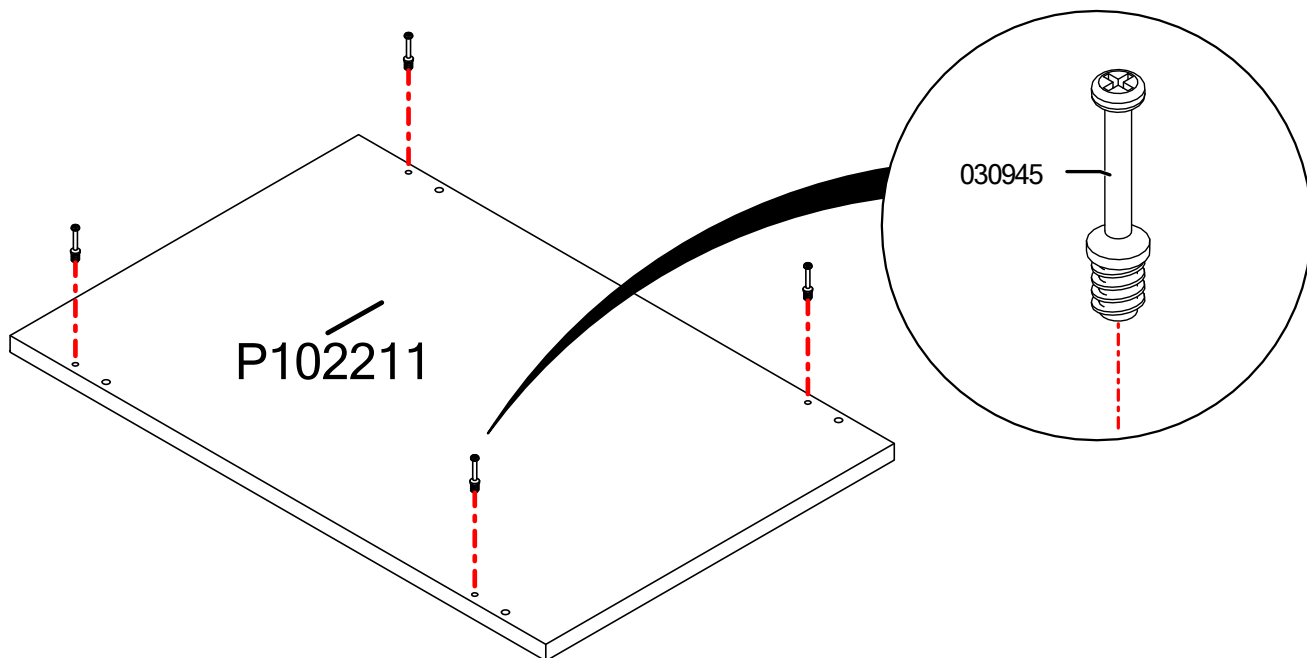

PASSO / PASO / STEP 4

Cód. / Cod	Quant. / Cantid. / A
001802	8

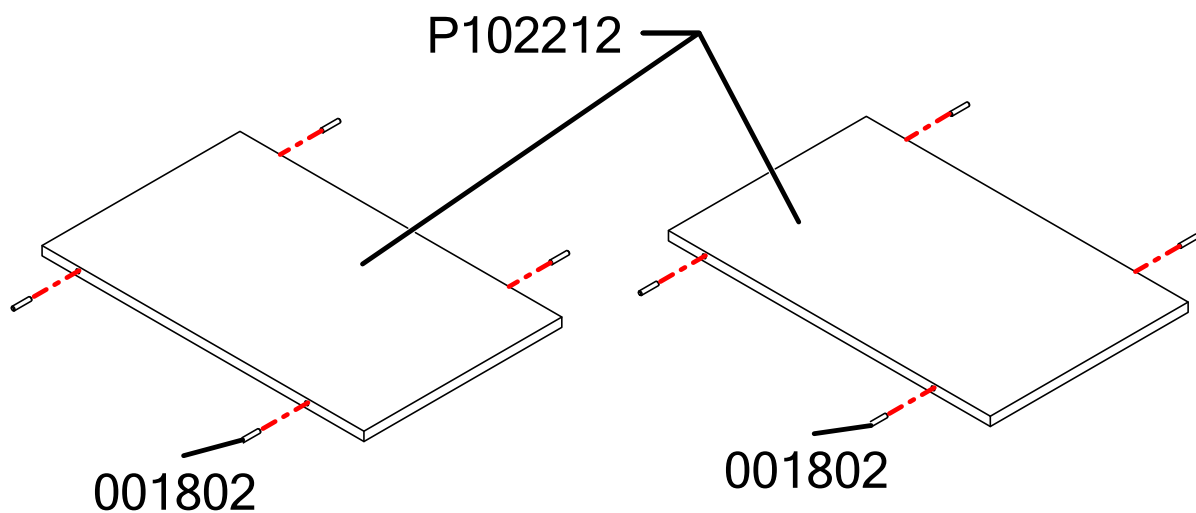

PASSO / PASO / STEP 5

Cód. / Code	Quant. / Cantid. / Am
001802	4

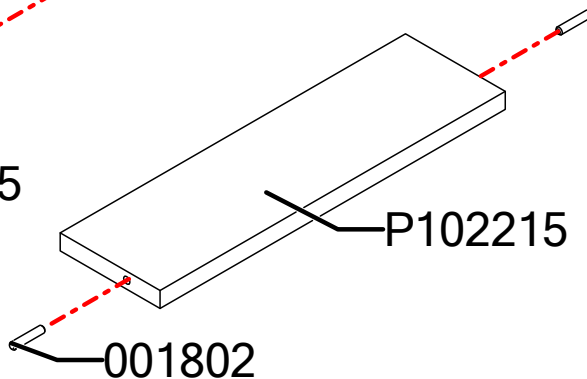
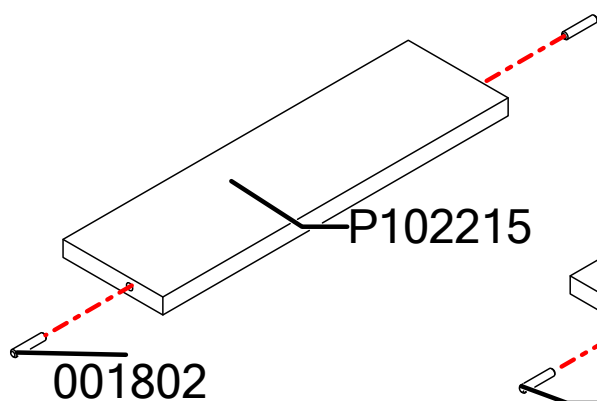

PASSO / PASO / STEP 6

Cód. / Code	Quant. / Cantid. / Am
001802	4

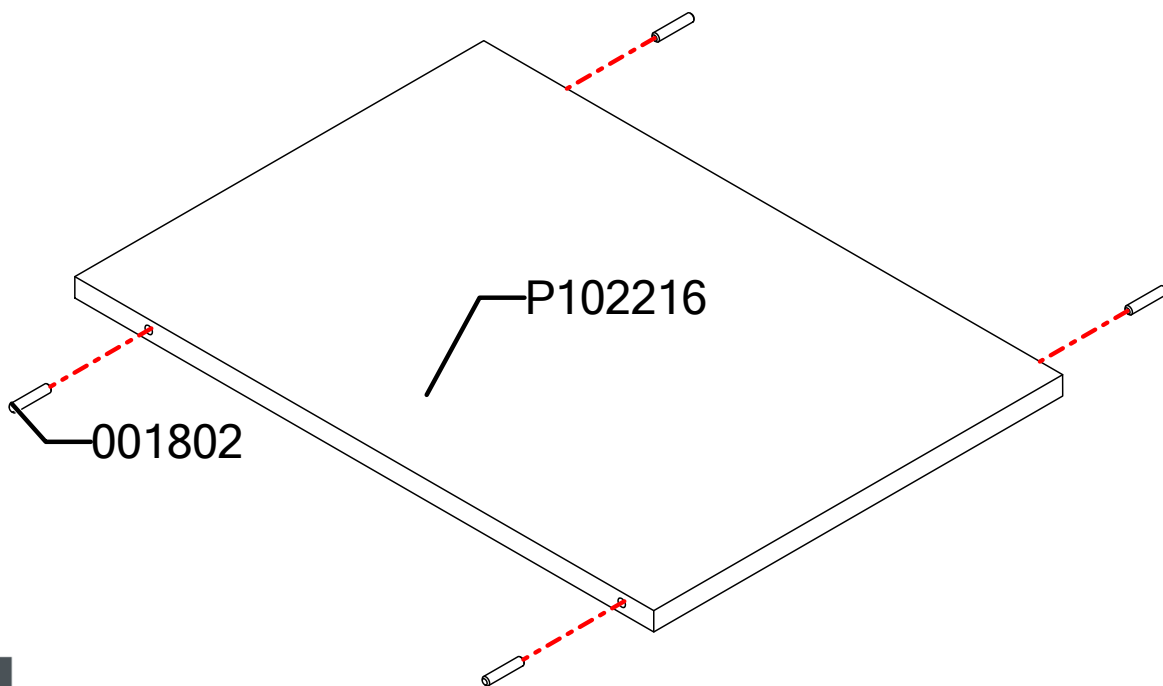

PASSO / PASO / STEP 7

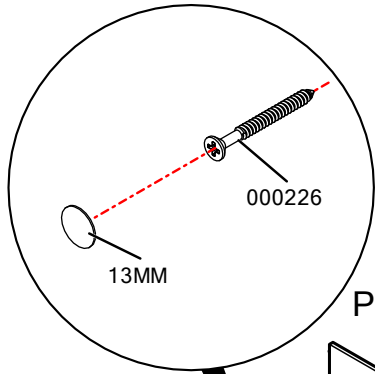

Cód. / Code	Quant. / Cantid. / Ar
13MM	16
000226	16

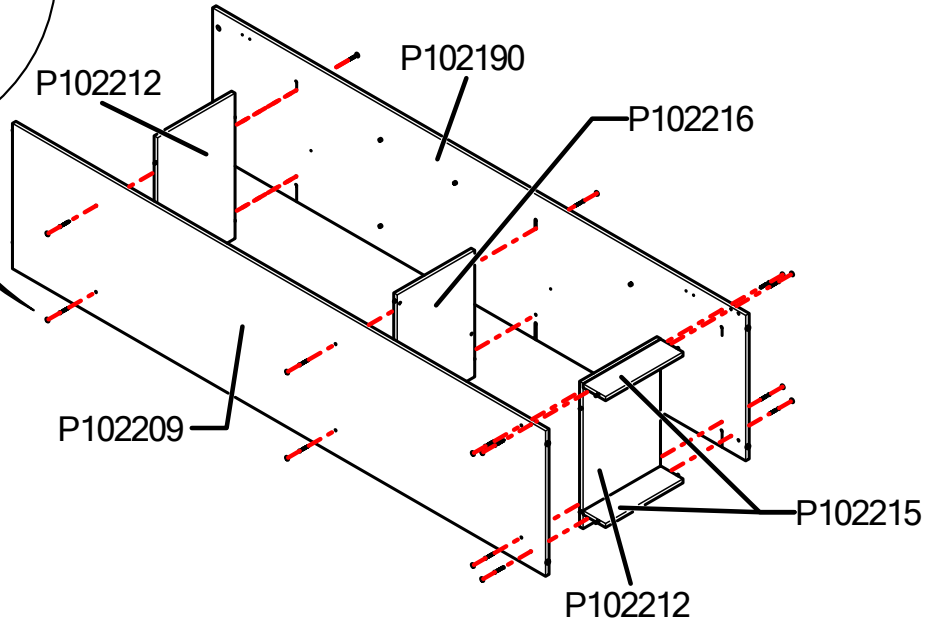

PASSO / PASO / STEP 8

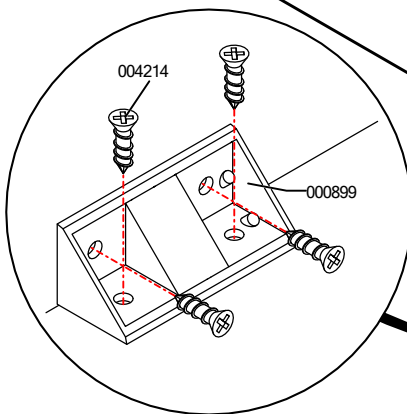

Cód. / Code	Quant. / Cantid. / Amo
000899	2
004214	8

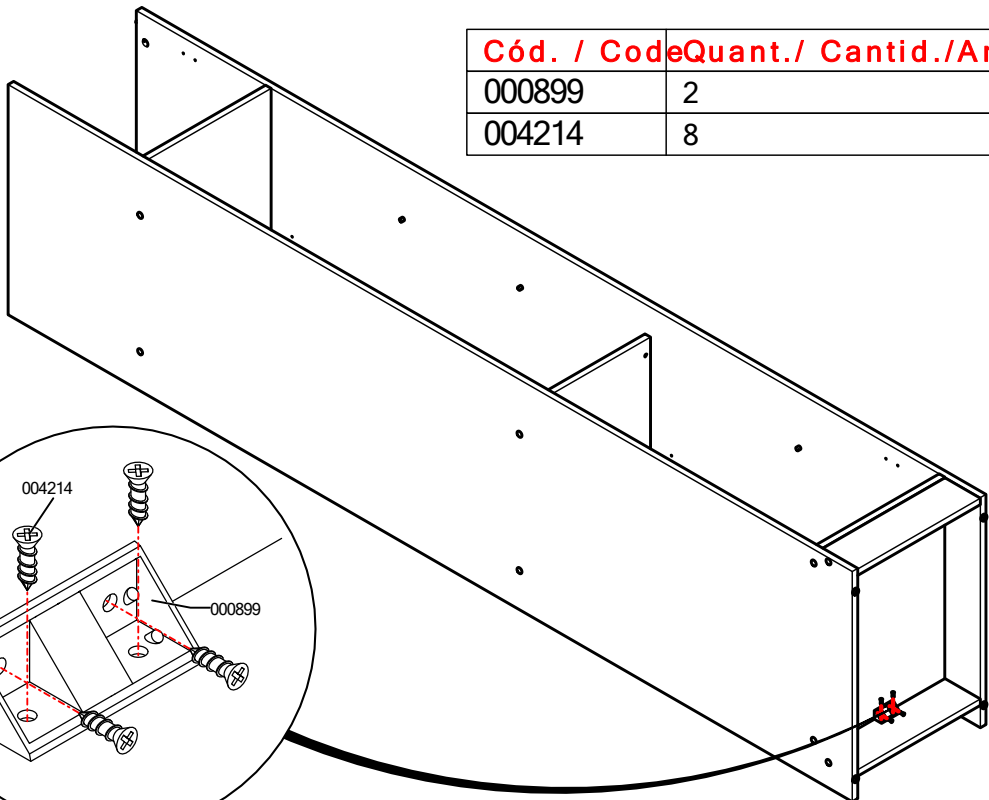

PASSO / PASO / STEP 9

Cód. / Cod	Quant. / Cantid.	Ar
19MM	4	
030950	4	

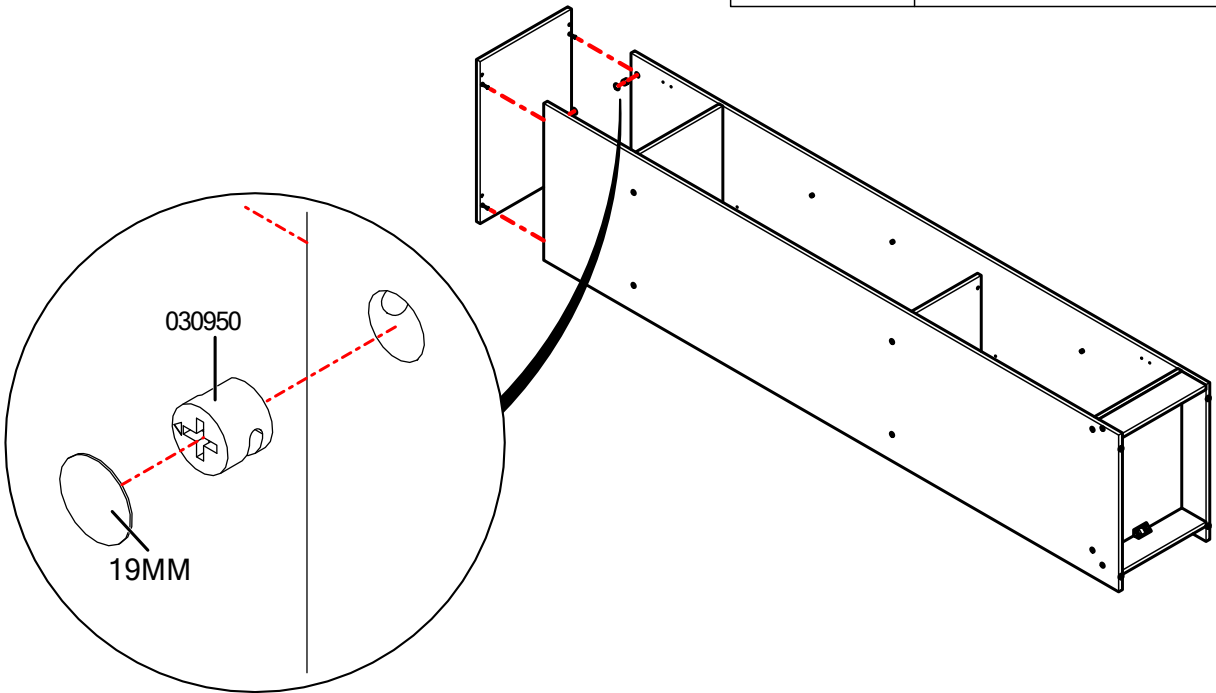

PASSO / PASO / STEP 10

Cód. / Cod	Quant. / Cantid.	Ar
000107	53	

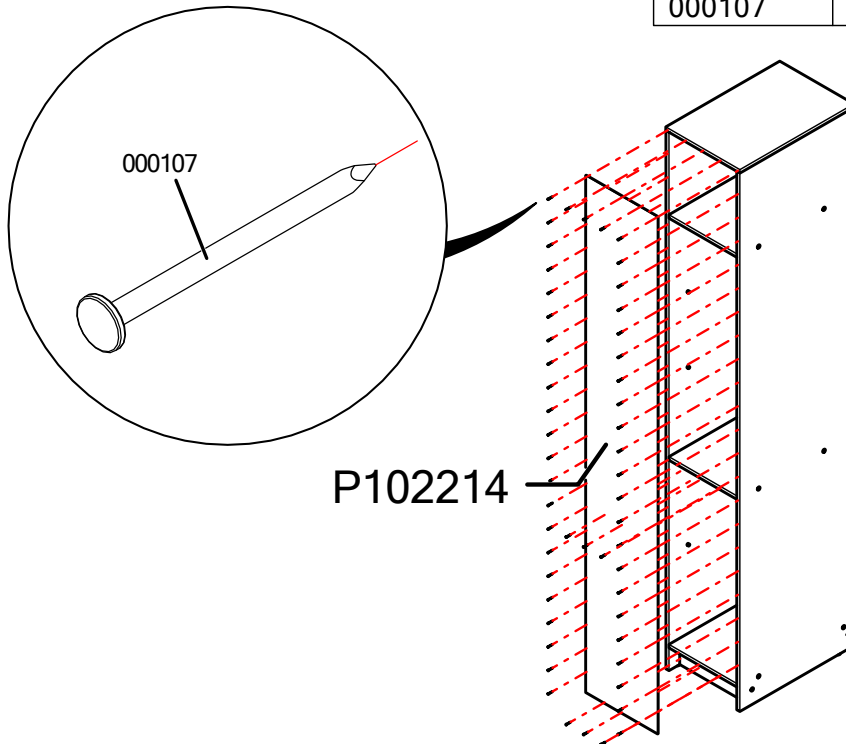

PASSO / PASO / STEP 11

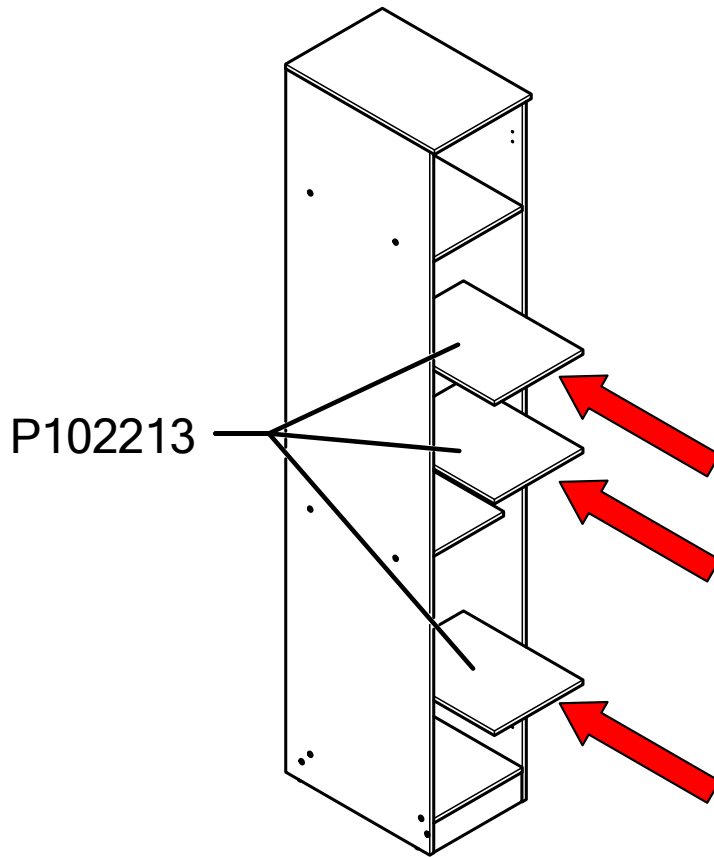

PASSO / PASO / STEP 12

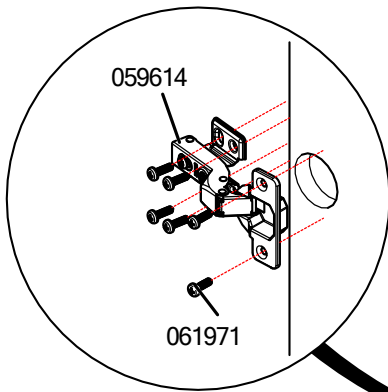

Cod.	Qtde.
059614	3
061971	18

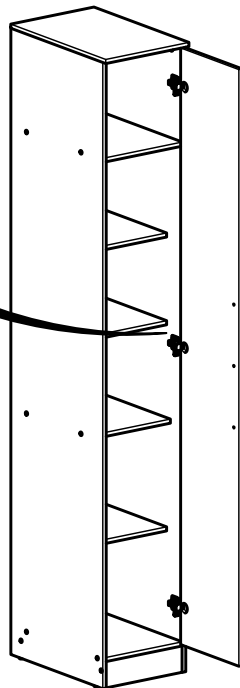

ARM36AMDP