

Manual de montagem

Instrucciones de montaje Assembly instructions

AER36AMDP

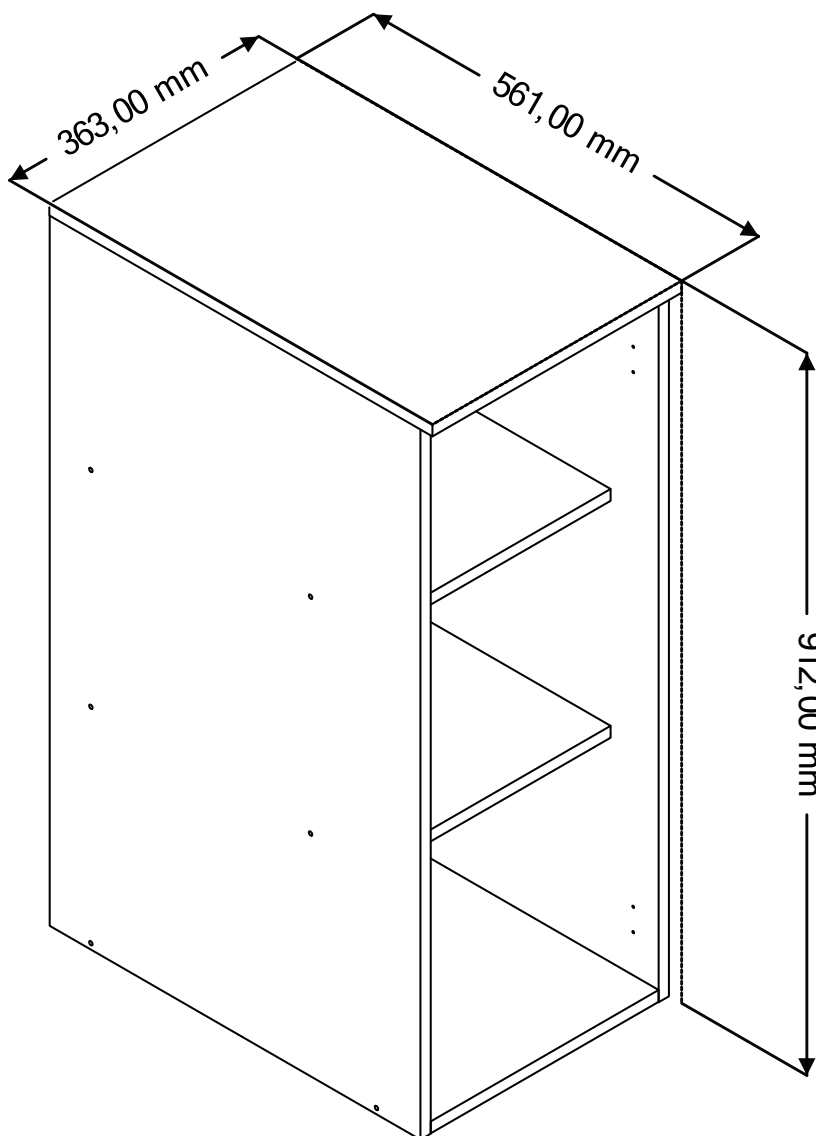

! Imagens meramente ilustrativas !
Imágenes ilustrativas/Images merely illustrative.

Dúvidas? Entre em contato:
Dudas? Ponerse em contacto:
Doubts? Get in touch:
(51) 3635-8839

A montagem deve ser efetuada por 2 pessoas.

El montaje debe ser efectuada por 2 personas.

The assembly must be done by 2 people.

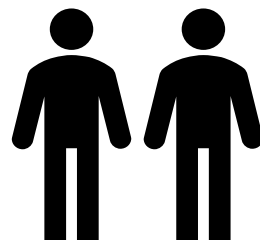

Ferramentas necessárias para montar o móvel.

Herramientas necesarias para armar el mueble.

Tools needed to assemble the furniture.



Dúvidas? Entrar em contato:

Dudas? Ponerse en contacto:

Doubts? Get in touch:

Fone: (51) 3635-8839

www.kappesberg.com.br



Montar o móvel sobre uma superfície limpa e plana.

Armar el mueble sobre una superficie limpia y plana.

Assemble the furniture on a clean, flat surface.

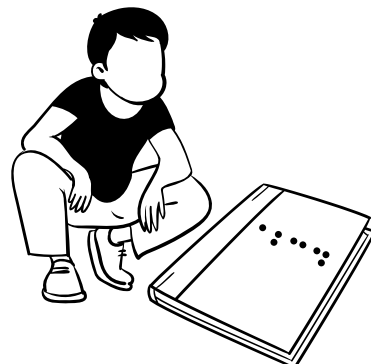

**IDENTIFICAÇÃO DAS PEÇAS / IDENTIFICACIÓN DE LAS PIEZAS PARTS
IDENTIFICATION**

Quantidade / Cantidad / Amount	Código / Code	Descrição	Descripción	Description	C x L x E	L x W x T
1	P102384	LATERAL DIREITA	LADO DIRECTO	RIGHT SIDE	897 x 540 x 15 mm	35.31 x 21.26 x 0.59 in
1	P102385	BASE	BASE	BASE	332 x 540 x 15 mm	13.07 x 21.26 x 0.59 in
1	P102387	LATERAL ESQUERDA	LADO EZQUIERDO	LEFT SIDE	897 x 540 x 15 mm	35.31 x 21.26 x 0.59 in
1	P102211	CHAPÉU	SOMBRERO	HAT	363 x 558 x 15 mm	14.29 x 21.97 x 0.59 in
1	P102386	COSTA	COSTA	COAST	902 x 352 x 3 mm	35.51 x 13.86 x 0.12 in
2	P102455	PRATELEIRA	PRATELEIRA	PRATELEIRA	332 x 470 x 15 mm	13.07 x 18.50 x 0.59 in

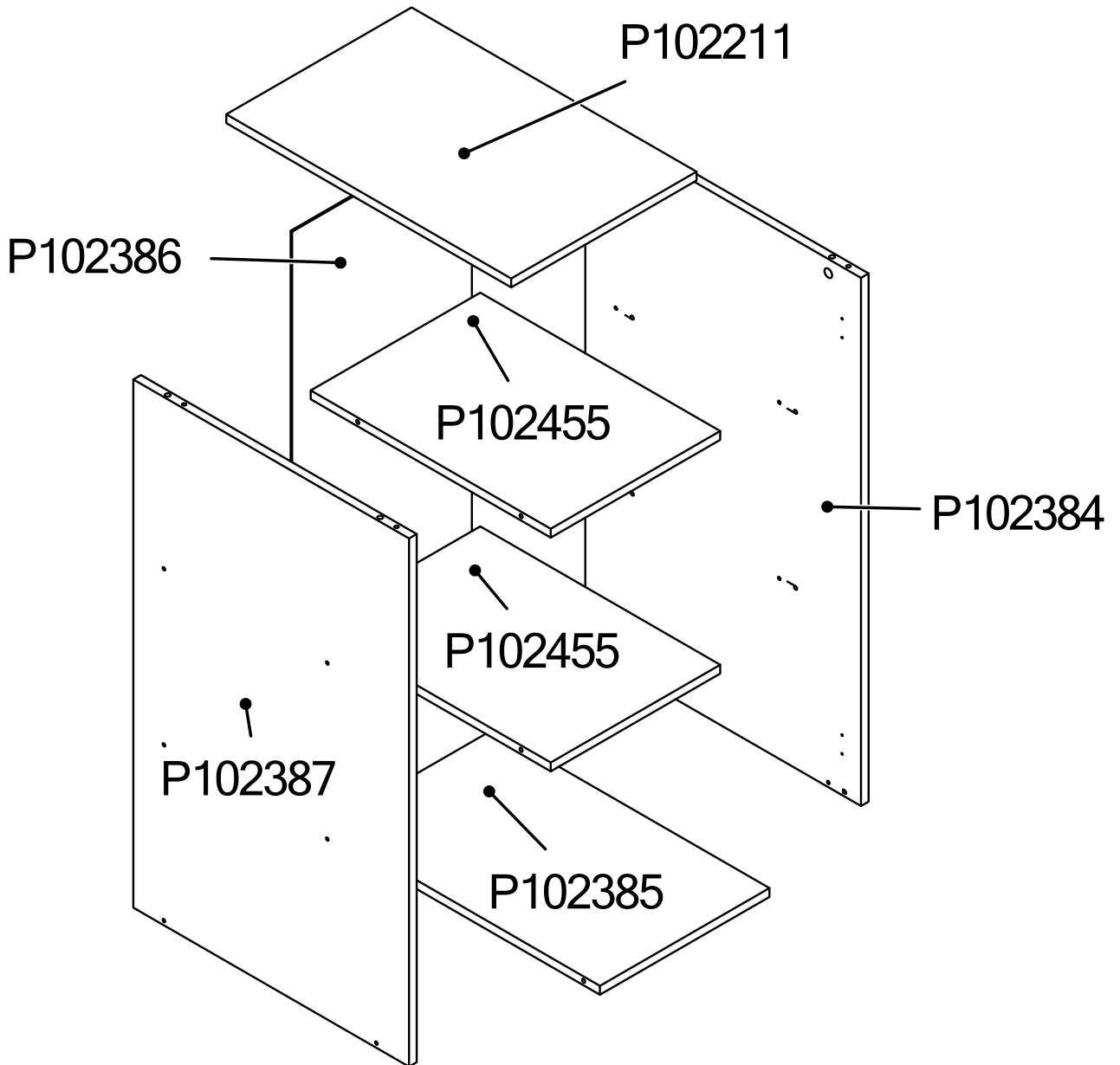

IDENTIFICAÇÃO DOS ACESSÓRIOS / IDENTIFICACIÓN DE ACCESORIOS
IDENTIFICATION OF ACCESSORIES

NOTAS: A separação dos acessórios antes de iniciar a montagem facilitará a mesma. Em caso de dúvida na identificação, coloque o acessório sobre a régua.

Nota: Separar los accesorios antes de iniciar el montaje facilitará el mismo. En caso de duda en la identificación, coloque el accesorio en la regla.

NOTE: Separating the accessories before starting assembly will make it easier. In case of doubt in the identification, place the accessory on the ruler.

	Quantidade / Cantidad / Amount	Código / Code	Descrição	Descripción	Description
	16	001802	CAVILHAS DE MADEIRA 6X30 PINUS	TARUGO 6X30MM	DOWEL 6X30MM
	4	030950	TAMBOR P/ MINIFIX 15MM ZAMAQ 09.11.007	CILINDRO 15MM	BARREL 15MM
	4	030945	PARAFUSO DE ACO P/ MINIFIX	TORNILLO DE ACERO PARA MINIFIX	STEEL SCREW FOR MINIFIX
	12	000226	P.CHATO 4,0 X 40MM	TORNILLO 4,0 X 40MM	SCREW 4,0 X 40MM
	12	TAPA FURO 13MM	TAPA FURO 13MM	TAPA DEL AGUJERO 13MM	SCREW CAP COVER 13MM
	4	TAPA FURO 19MM	TAPA FURO 19MM	TAPA DEL AGUJERO 19MM	SCREW CAP COVER 19MM

IDENTIFICAÇÃO DOS ACESSÓRIOS / IDENTIFICACIÓN DE ACCESORIOS IDENTIFICATION OF ACCESSORIES

	30	000107	PREGO 10 X 10 (0,308G) LISO	CLAVO 10 X 10	NAIL 10 X 10
	2	017024	SUP. AEREO METALICO ZINCADO BRANCO (04.08.150)	SUP. AEREO METALICO ZINCADO BRANCO (04.08.150)	SUP. AEREO METALICO ZINCADO BRANCO (04.08.150)
	4	004214	P.CHATO 3,5 X 14 CAB. PHILLIPS REBAIXADA ZB	TORNILLO 3,5 X 14MM	SCREW 3,5 X 14MM
	2	050311	P.FLANGE 5,0 X 65 CAB. PHILLIPS ZB/BC	TORNILLO 5,0 X 65	SCREW 5,0 X 65
	2	000529	BUCHAS NYLON MU 8 CINZA (2001003279)	CASQUILLO DE FIJACIÓN DE NYLON	NYLON FIXING BUSHING
	2	006959	CAPA P/SUP. AEREO METAL BRANCA 10.05.042 (005)	CUBIERTA DE SOPORTE	SUPPORT COVER
	5	054117	P.CHATO 3,5 X 25 CAB. PHILLIPS ZB/BC (IDELLI)	TORNILLO 3,5 X 25	SCREW 3,5 X 25
	2	051322	DOBRAD. RETA 35MM C/ CALCO FIXO E AMORTECEDOR	BISAGRA DE CALCE	SHIMS AND HINGES
	12	061971	P.PANELA 4,0 X 14 ZB P/DOBRADICA	TORNILLO 4,0 X 14	SCREW 4,0 X 14

INSTALAÇÃO MINIFIX

Identificar seta no corpo do tambor de minifix. A seta DEVE apontar para o buraco na borda do painel. Empurrar o tambor até o buraco.

INSTALACIÓN DE LA LEVA

Identifique la flecha en los muertos de la leva. La flecha debe apuntar hacia el agujero en el borde del panel. Empuje la leva hasta el fondo del orificio.

INSTALLING CAM

Identify arrow on head of cam. Arrow MUST point toward hole in edge of panel. Push cam all the way down into hole.

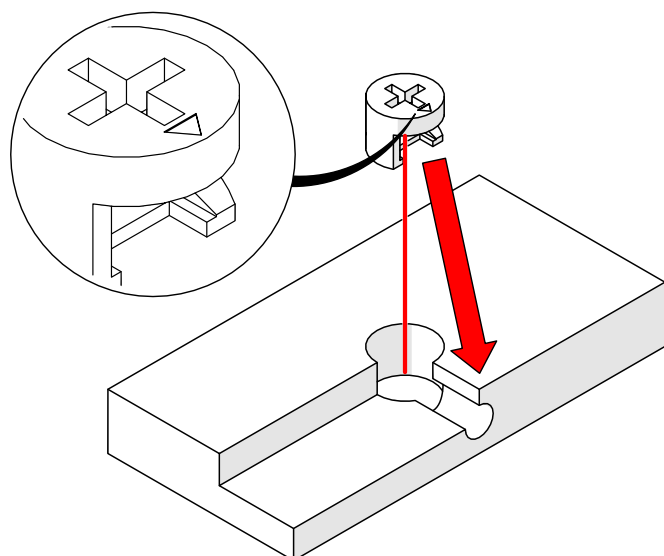

ALINHAMENTO DO TAMBOR E PARAFUSO

A seta do tambor de minifix deve ser aponta para o buraco e inserir o parafuso do minifix do tambor contido no buraco. Certifique-se de que as peças se unam.

ALINEACIÓN DE LA LEVA Y EL PASADOR

Asegúrese de que la flecha de la leva apunte hacia el orificio e inserte la clavija de la leva en el orificio. Asegúrese de que las piezas se unen.

CAM AND DOWEL ALIGNMENT

Ensure the arrow on the cam points toward hole and insert cam dowel into hole. Make sure pieces join together.

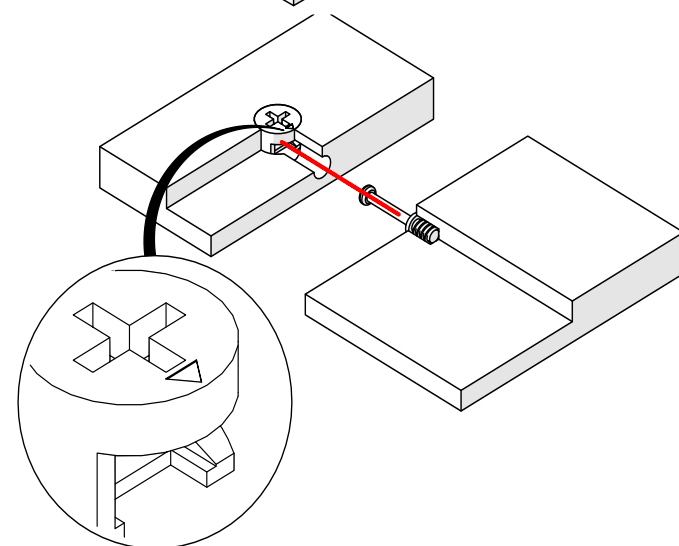

CÂMARA DE COMPENSAÇÃO DE TENSÃO

Use uma chave de fenda para girar a came. Girar o tambor minifix (no sentido horário) até que esteja totalmente apertado. Ligeiramente mais de meia volta.

APRIETE DE LA LEVA

Utilice un destornillador para girar la leva. Gire la leva (en el sentido de las agujas del reloj) hasta que esté completamente apretada. Un poco más de media vuelta.

TIGHTENING CAM

Use screwdriver to turn cam. Turn cam (clockwise) until fully tightened. Slightly more than half a turn.

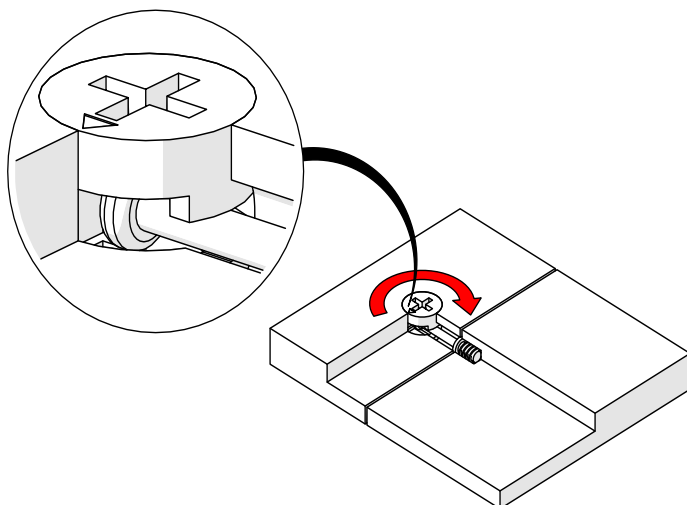

PASSO / PASO / STEP 1

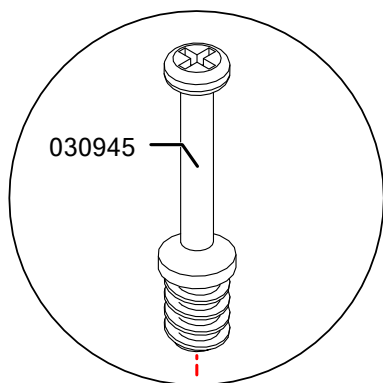

Cod.	Qtde.
030945	4

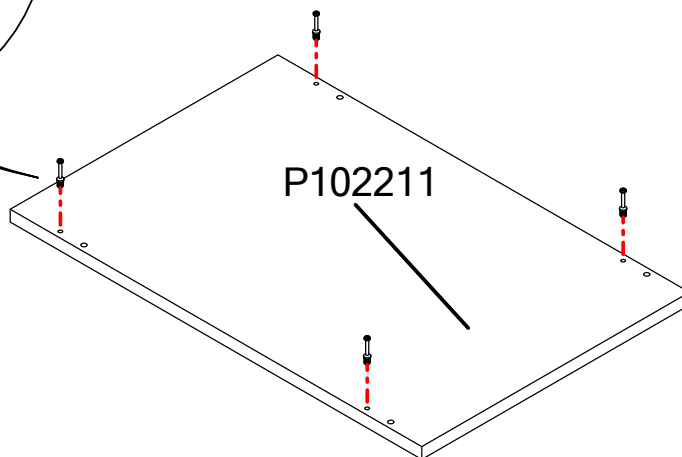

PASSO / PASO / STEP 2

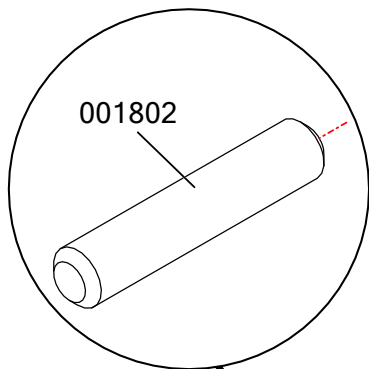

Cod.	Qtde.
001802	2

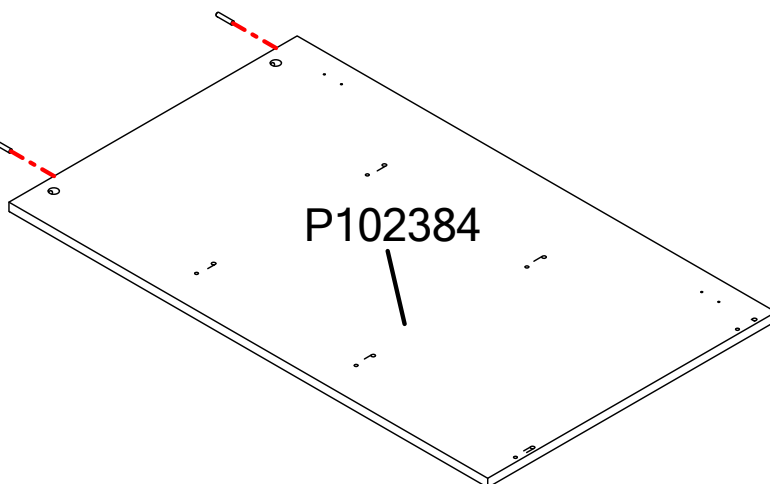

PASSO / PASO / STEP 3

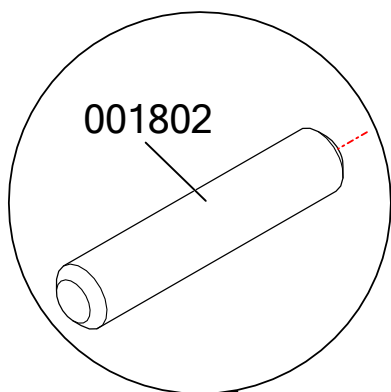

Cod.	Qtde.
001802	4

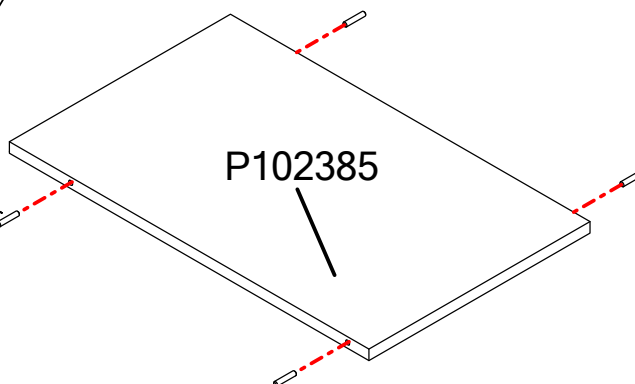

PASSO / PASO / STEP 4

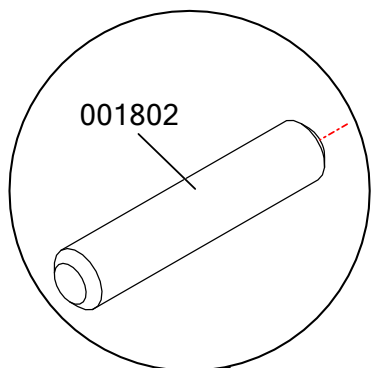

Cod.	Qtde.
001802	2

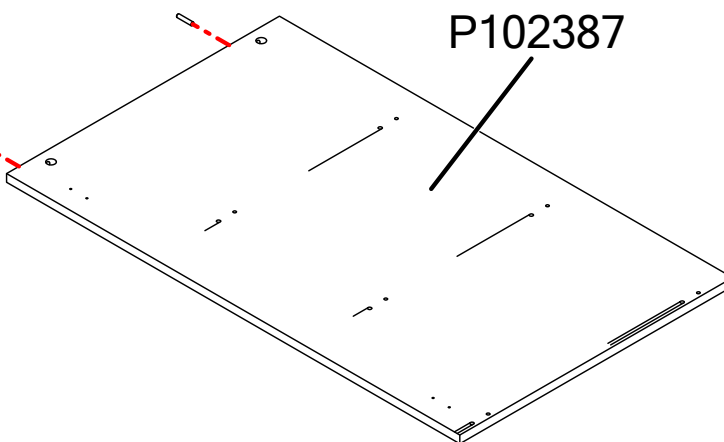

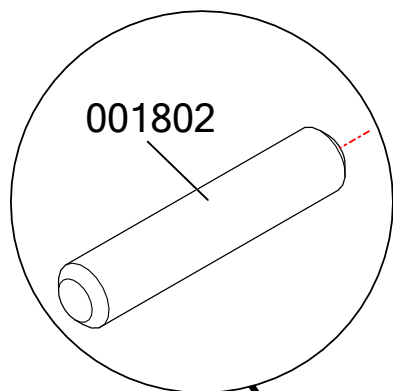

Cod.	Qtde.
001802	8

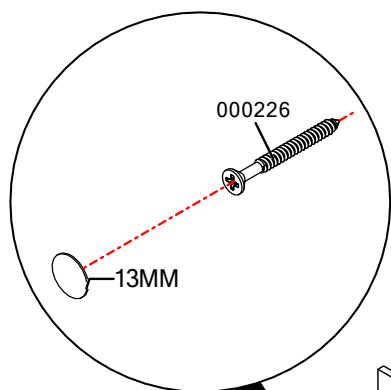
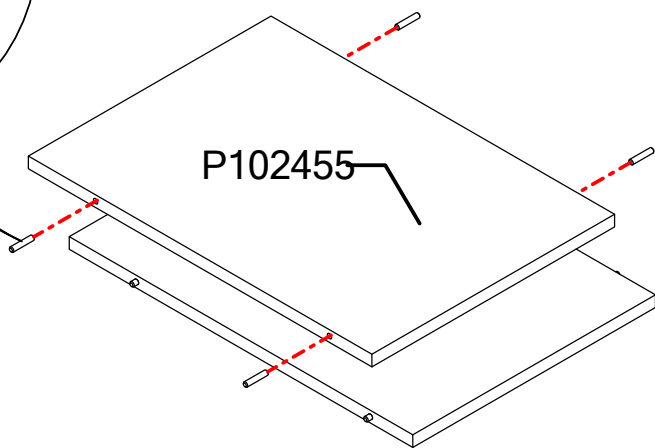

Cod.	Qtde.
000226	12
13MM	12

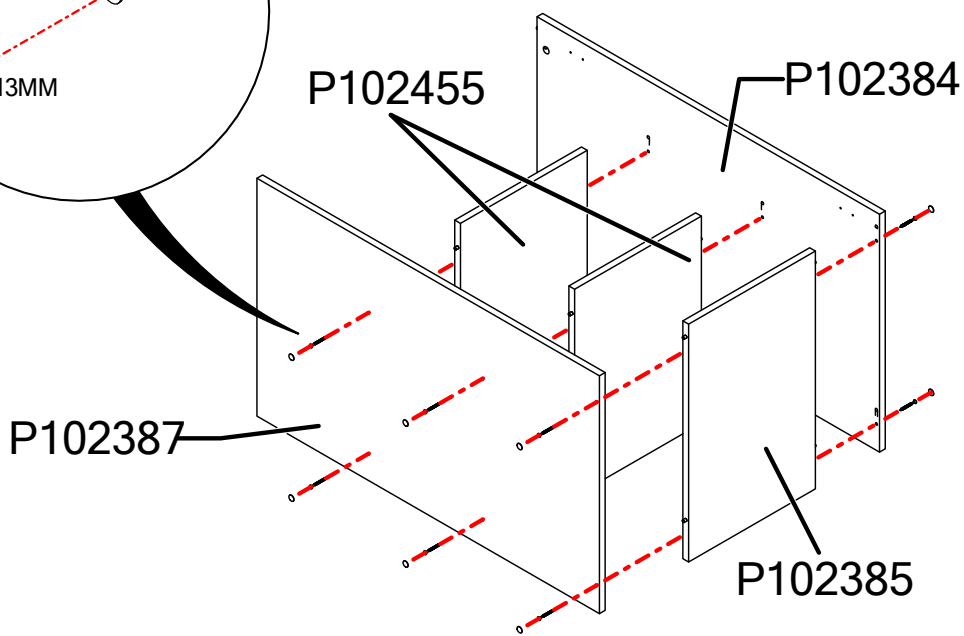

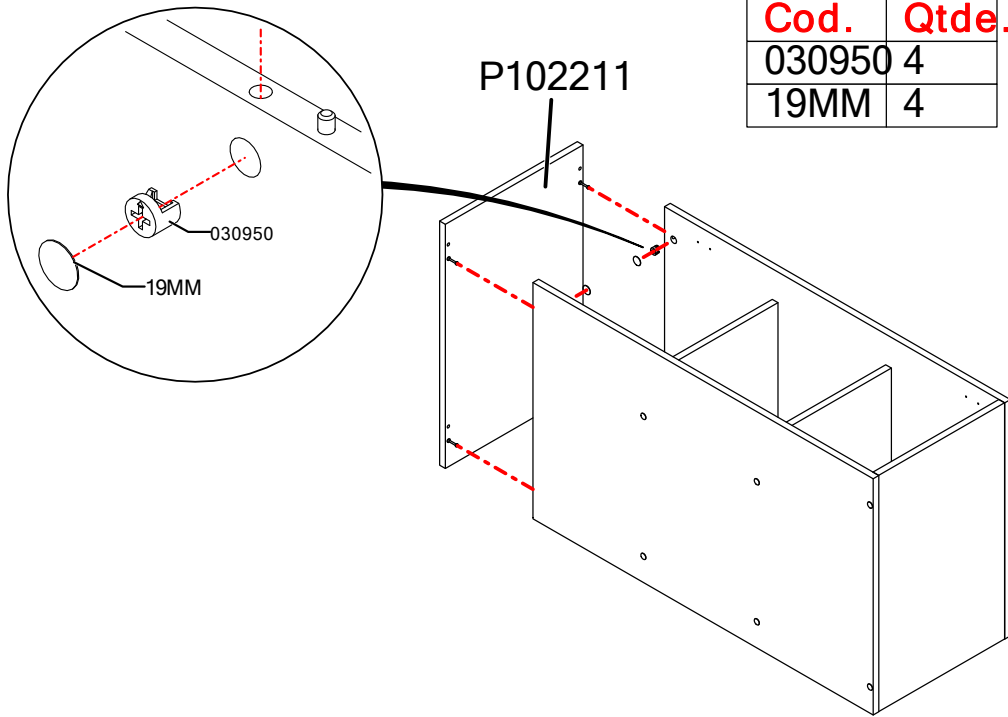

PASSO / PASO / STEP 6

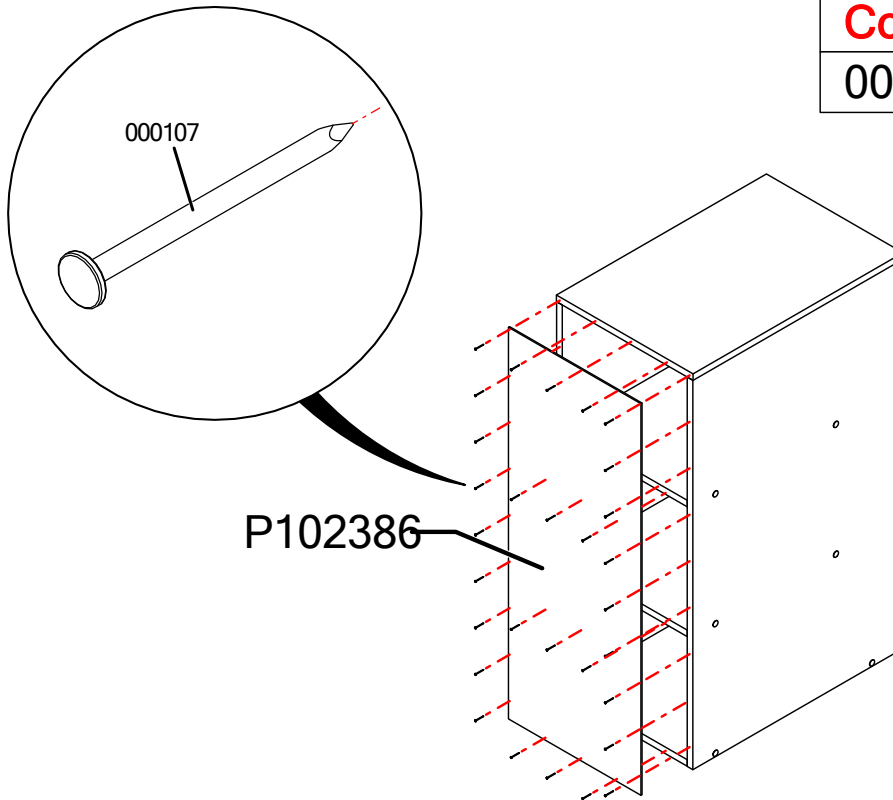

PASSO / PASO / STEP 7

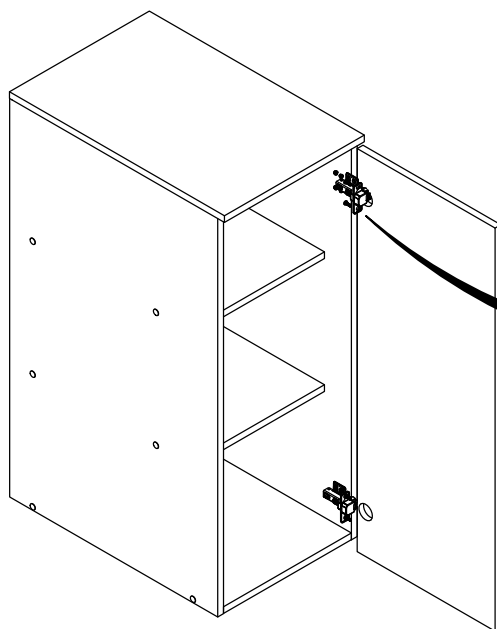

Cod.	Qtde.
051322	1
061971	12

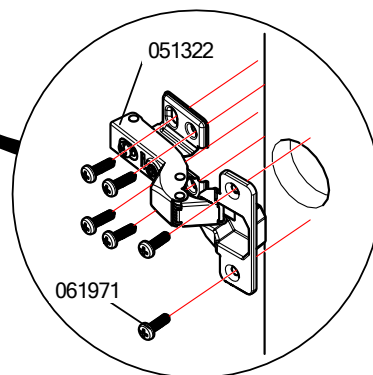

PASSO / PASO / STEP 8

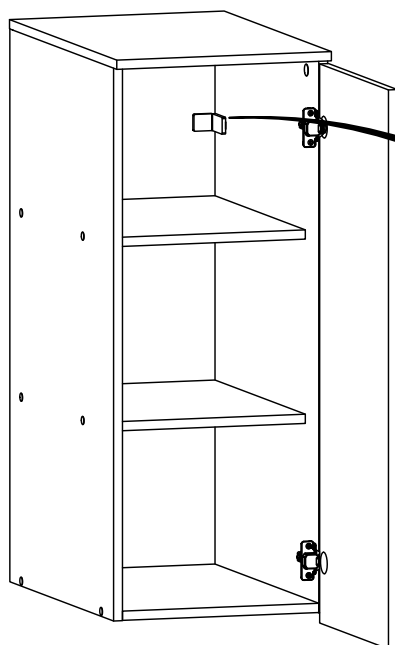

Cod.	Qtde.
000529	2
004214	4
006959	2
017024	2
050311	2

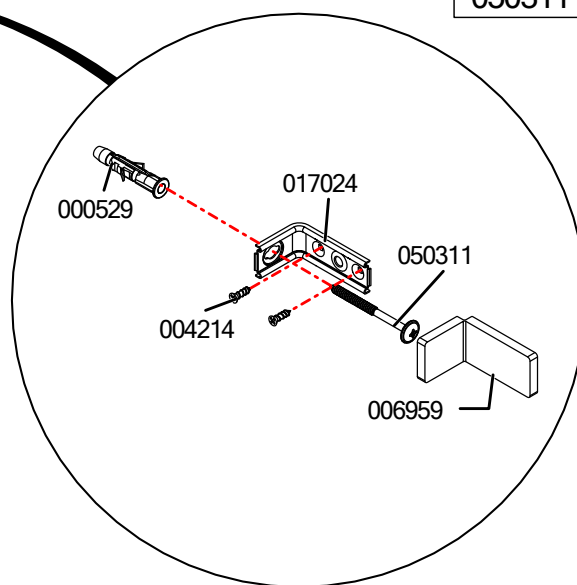

Manual de montagem

Instrucciones de montaje Assembly instructions

PA1AMDF358

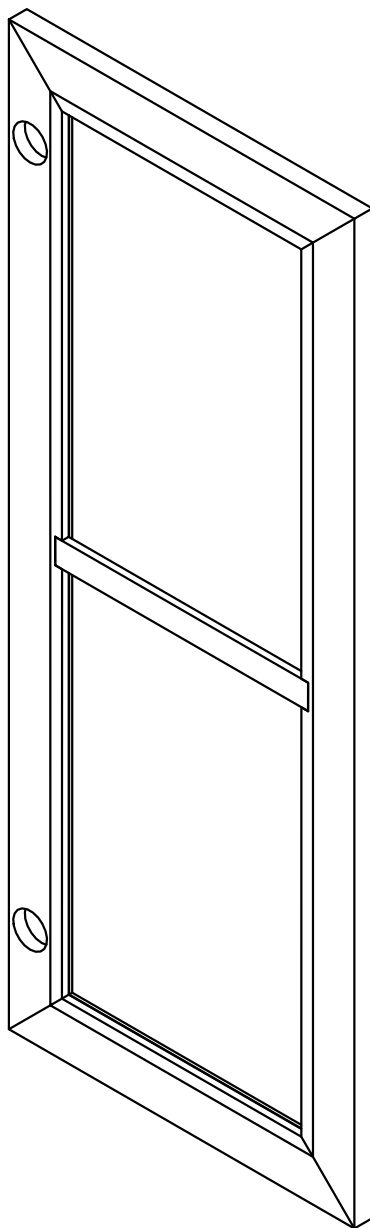

! Imagens meramente ilustrativas !
Imágenes ilustrativas/Images merely illustrative.

Dúvidas? Entre em contato:
Dudas? Ponerse em contacto:
Doubts? Get in touch:
(51) 3635-8839

A montagem deve ser efetuada por 2 pessoas.

El montaje debe ser efectuada por 2 personas.

The assembly must be done by 2 people.

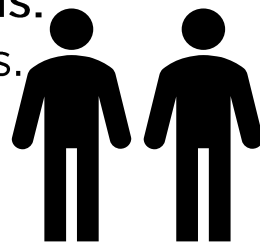

Ferramentas necessárias para montar o móvel.

Herramientas necesarias para armar el

mueble Tools needed to assemble the furniture.



Dúvidas? Entrar em contato:

Dudas? Ponerse en
contacto:

Doubts? Get in touch:

Fone: (51) 3635-8839

www.kappesberg.com.br



Montar o móvel sobre uma superfície limpa e plana.

Armar el mueble sobre una superficie limpia y plana.

Assemble the furniture on a clean, flat surface.

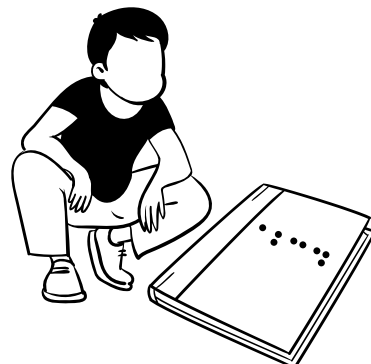

IDENTIFICAÇÃO DAS PEÇAS / IDENTIFICACIÓN DE LAS PIEZAS PARTS IDENTIFICATION

Quantidade / Cantidad / Amount	Código / Code	Descrição	Descripción	Description
1	076184	PORTA 907 X 358 X 18MM	PUERTA 907 X 35 X 18MM	DOOR 907 X 358 X 18MM

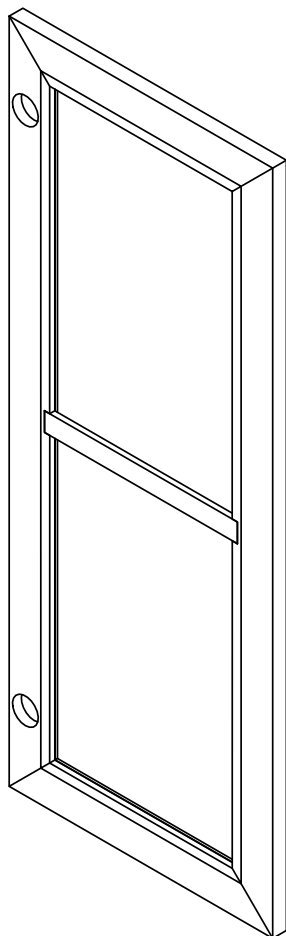

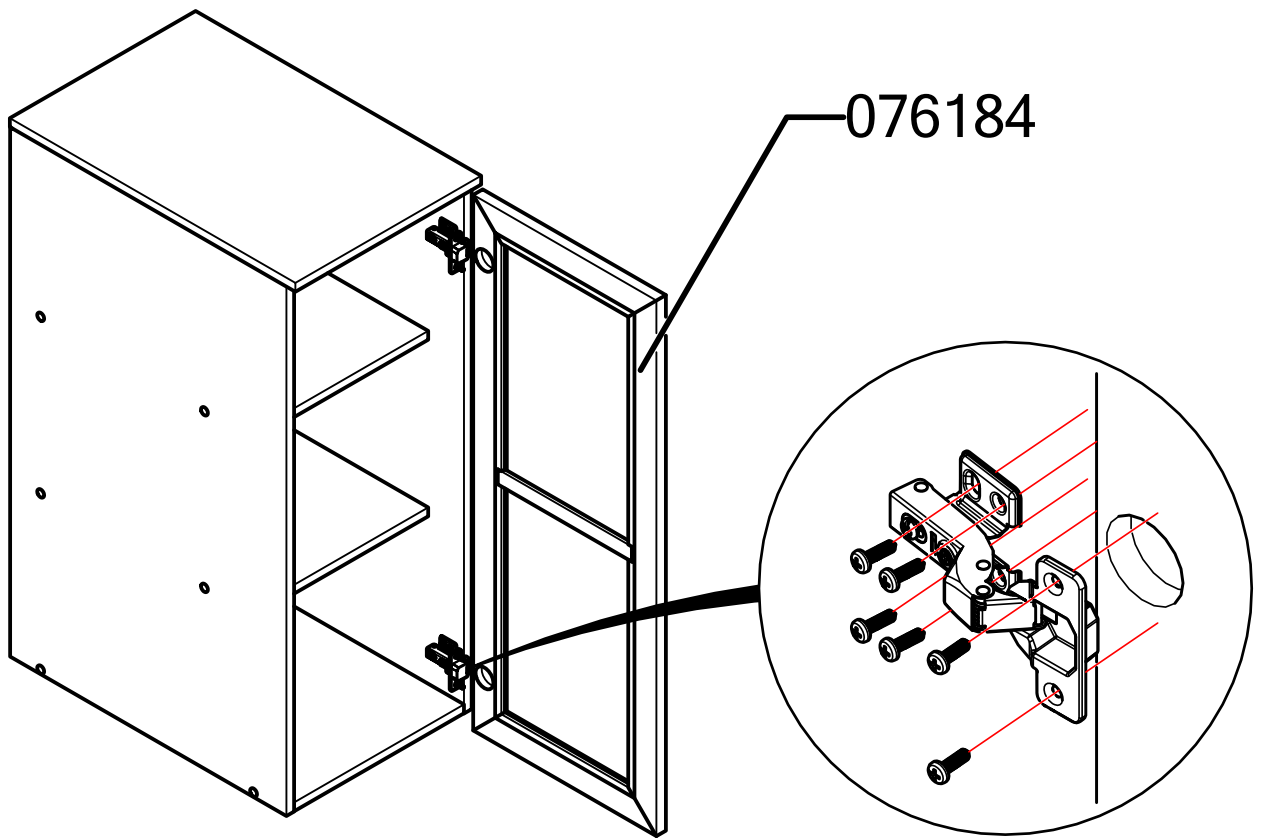

Ajuste de portas
Ajuste de puerto
Doors Adjustment

Ajuste de altura
Height Adjustment

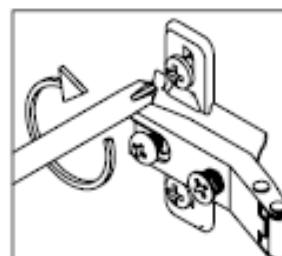
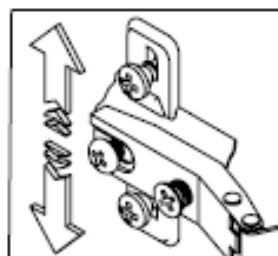
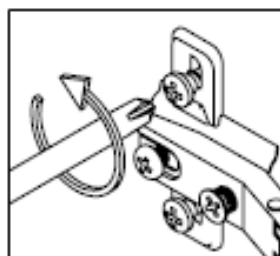
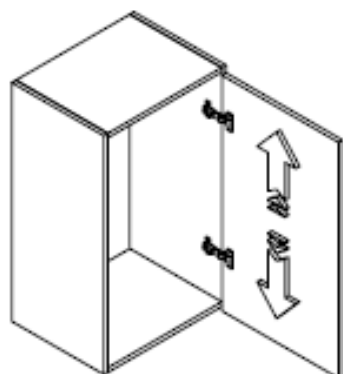

Ajuste Interno
Internal Adjustment

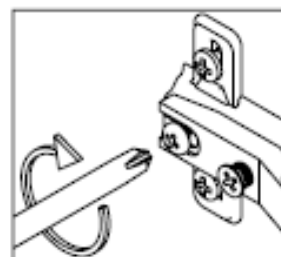
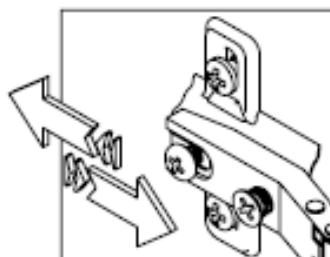
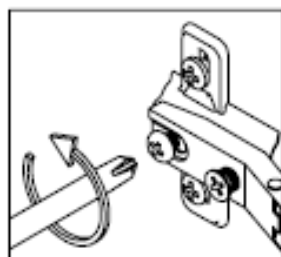
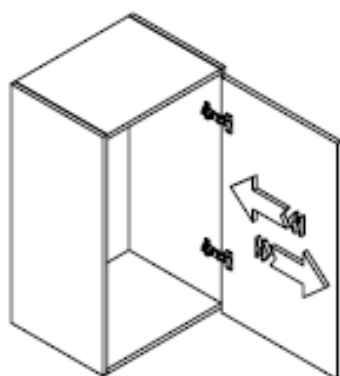

Ajuste de Profundidade
Ajuste de profundidad
Depth Adjustment

