



Incorplac
Rua Jurutau 3150 | Parque Industrial II
CEP 86703-070 | Arapongas | PR | Brasil
www.Incorplac.com.br

COZINHA PRÁTICA LARISSA (2200mm)

ESQUEMA DE MONTAGEM | ASSEMBLY INSTRUCTIONS | ESQUEMA DE MONTAJE



ATENDIMENTO AO CONSUMIDOR
Attendance to the consumer | Asistencia al consumidor
Whatsapp: +55 (43) 3172-4150

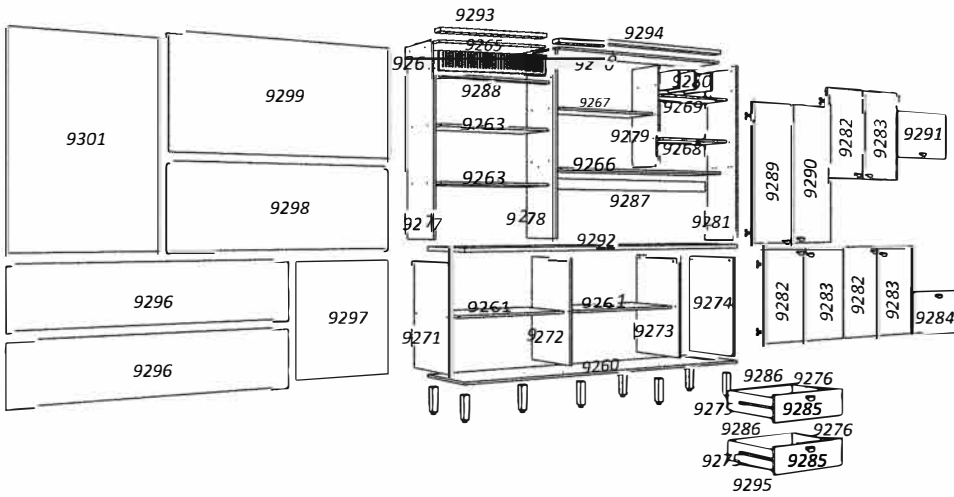

REF.:	PEÇAS PIECE PIEZA	QUANT.	DIMENSÕES* DIMENSIONS DIMENSIONES	MATÉRIA PRIMA
9260	Base Balcão	1	2202 x 450 x 15	MDP
9261	Prateleira do Balcão	2	772 x 432 x 15	MDP
9263	Prateleira Superior Esquerda	2	781 x 312 x 15	MDP
9264	Vista Detalhe a Laser	1	781 x 70 x 15	MDP
9265	Chapéu Esquerdo	1	781 x 312 x 15	MDP
9266	Base Superior Direita	1	1370 x 300 x 15	MDP
9267	Prateleira Direita	1	773 x 282 x 15	MDP
9268	Prateleira / Base Direita	1	582 x 282 x 15	MDP
9269	Base Nicho Garrafeira	1	582 x 282 x 15	MDP
9270	Chapéu (carimbar n° do lote)	1	1370 x 282 x 15	MDP
9271	Lateral Esquerda do Balcão	1	680 x 450 x 15	MDP
9272	Divisória da Prateleira do Balcão	1	680 x 432 x 15	MDP
9273	Divisória do Balcão Direita	1	680 x 450 x 15	MDP
9274	Lateral Direita do Balcão	1	680 x 450 x 15	MDP
9275	Lateral de Gaveta Esquerda	2	400 x 120 x 15	MDP
9276	Lateral de Gaveta Direita	2	400 x 120 x 15	MDP
9277	Lateral Esquerda Superior	1	1210 x 330 x 15	MDP
9278	Divisória Central Superior	1	1210 x 330 x 15	MDP
9279	Divisória Superior Direita	1	665 x 282 x 15	MDP
9280	Divisória Nicho Garrafeira	3	282 x 125 x 15	MDP
9281	Lateral Direita Superior	1	1210 x 300 x 15	MDP
9282	Porta Esquerda	3	674 x 387 x 15	MDP
9283	Porta Direita	3	674 x 387 x 15	MDP
9284	Porta Inferior Direita	1	585 x 336 x 15	MDP
9285	Frente de Gaveta	2	585 x 167 x 15	MDP
9286	Contra Fundo Gaveta	2	536 x 120 x 15	MDP
9287	Trava	1	1370 x 70 x 15	MDP
9288	Vista Aplique	1	781 x 120 x 15	MDP
9289	Porta Superior Maior Esquerda	1	1029 x 387 x 15	MDP
9290	Porta Superior Maior Direita	1	1029 x 387 x 15	MDP
9291	Porta Superior Menor Direita	1	585 x 362 x 15	MDP
9292	Tampo Balcão	1	2202 x 450 x 25	MDP
9293	Engrosso Chapéu Esquerdo	1	781 x 70 x 25	MDP
9294	Engrosso Chapéu Direito	1	1370 x 70 x 25	MDP
9295	Fundo Gaveta	2	566 x 405 x 3	MDP
9296	Traseiro Inferior Esquerdo	2	1580 x 350 x 3	MDP
9297	Traseiro Inferior Direito	1	700 x 611 x 3	MDP
9298	Traseiro Superior Esquerdo - Menor	1	802 x 350 x 3	MDP
9299	Traseiro Superior Esquerdo - Maior	1	802 x 485 x 3	MDP
9300	Traseiro Central / Superior Direito	1	1390 x 505 x 3	MDP
9301	Traseiro Superior Porta	2	787 x 340 x 3	MDP
9302	Traseiro Superior Porta/Nicho	1	680 x 603 x 3	MDP
9304	Aplique Laser	1	771 x 134 x 3	MDP

INSTRUÇÕES | INSTRUCTIONS | INSTRUCCIONES

- * Prepare a montagem do móvel próximo ao local que ele ficará definitivamente e evite deslocá-lo depois de montado;
- * Forre o chão com papelão ou similar e utilize a isomanta que vem entre as peças para evitar o contato entre elas durante a montagem;
- * Monte o móvel obedecendo a ordem numérica da sequência de montagem (S.M.), identificando as peças pelo código de peça (C.P.) carimbado na mesma, de acordo com a tabela.
- * Prepare the assembly of the close piece of furniture to the place that it will be definitively and avoid to move after done. Will be definitively and avoid to move after done;
- * Cover the ground with cardboard or similar and use the isomanta that it comes among the pieces to avoid the contact among them during the assembly;
- * Set up the piece of furniture obeying the numeric order of the assembly sequence (S.M.), identifying the pieces by code of piece (C.P.) stamped in the same, in agreement with the table.
- * Prepare la montaje del mobiliario proximo al lugar que estará definitivamente y evite mover después de hecho;
- * Tape la suelo con cartón o similar y use la "isomanta" que viene entre las piezas para evitar el contacto entre ellos durante la montaje;
- * Monte el mobiliario obedeciendo el orden numérico de la sucesión de montaje (S.M.), identificando las piezas por el código de piezas (C.P.) de la misma estampado en esta, de acuerdo con la tabla .



Pessoas necessárias para montagem



Ferramentas necessárias para montagem (não fornecidas)



Parafusadeira ou chave de fenda e philips

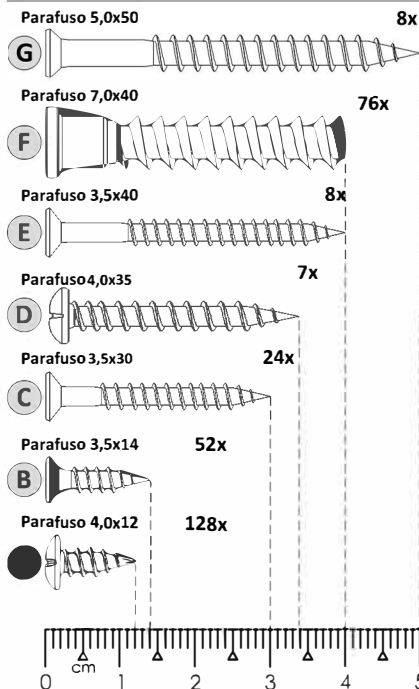

ACESSÓRIOS

H 4x Parafuso M4x25	I 200x Prego 1,0x10	J 18x Pino Gi rofi x	K 51x Cavi lha 8x30	L 4x Cavi lha 8x60	M 18x Tambor Gi rofi x
N 4x Porca M4	O 6x Fi ta dupla face	P 2x Cantoneira de Metal	Q 75x Fi xador Trasei ro	R 3x Gi zp/ correção	S 1x Eti queta Resi rada
T 6x Dobradi ça 35mm Curva	U 16x Dobradi ça 35mm Super Curva Slow Motion	V 12x Si li cone Batente 10mm	X 51x Tapa Furo Adesivo	W 2x Corrediça Telescópica Mini Ligh 350/30 mm	Y 8x Pé Belga 170mm
Z 12x Puxador Ni rbus	a 1x Batente Metáli ø				

1º PASSO / STEP / PASO

PEÇAS
PIECE
PIEZAS

S.M.	C.P.
01	9261
02	9271
03	9272

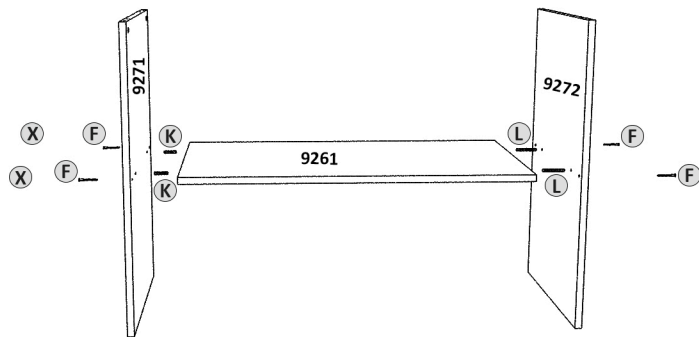
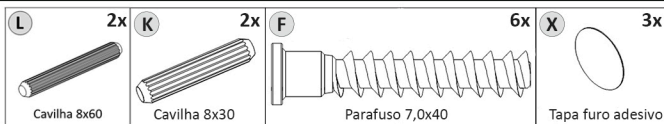

2º PASSO / STEP / PASO

PEÇAS
PIECES
PIEZAS

S.M.	C.P.
01	9261
02	9273

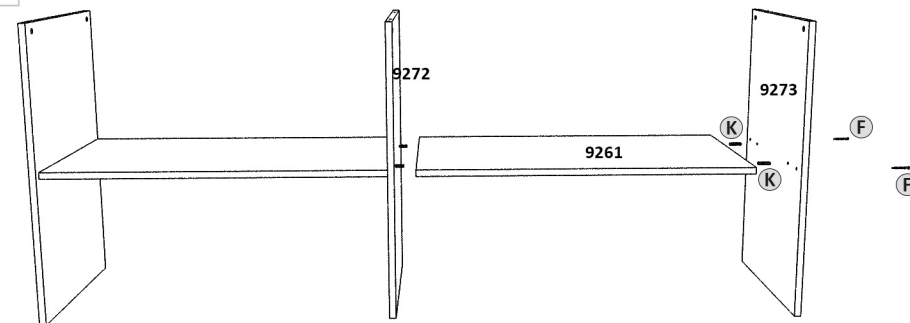
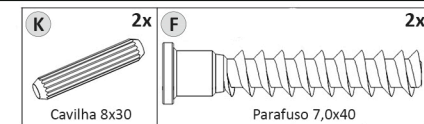

3º PASSO / STEP / PASO

PEÇAS
PIECES
PIEZAS

S.M.	C.P.
01	9260

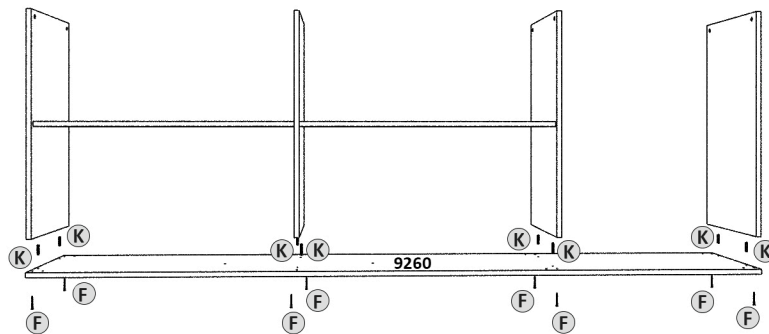
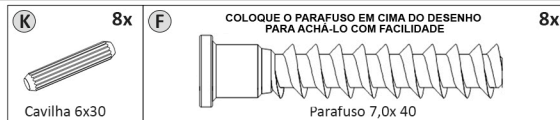

4º PASSO / STEP / PASO

PEÇAS
PIECES
PIEZAS

S.M.	C.P.
------	------

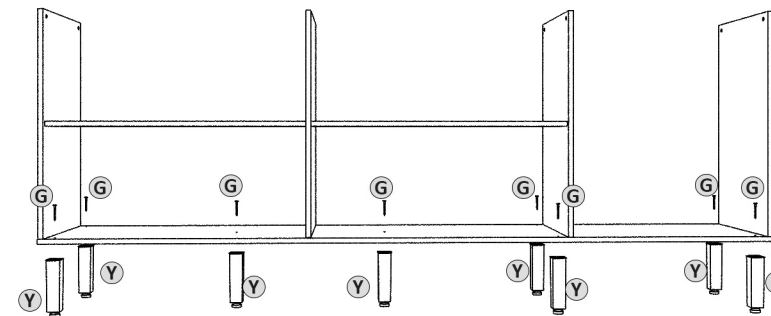
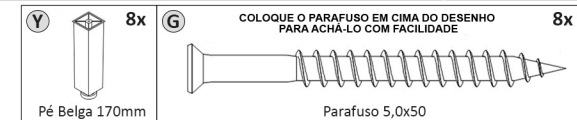

5º PASSO / STEP / PASO

PEÇAS
PIECES
PIEZAS

S.M.	C.P.
01	9264
02	9265
03	9288

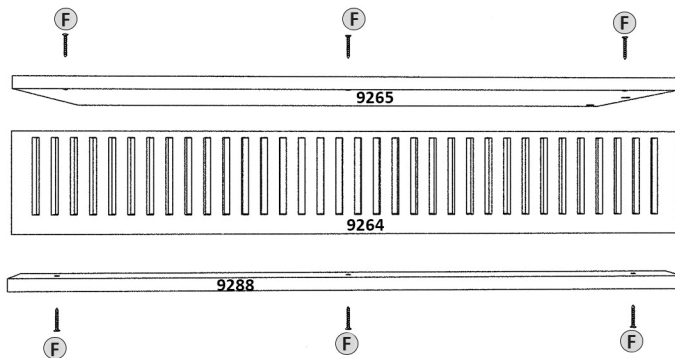

F COLOQUE O PARAFUSO EM CIMA DO DESENHO 6X
PARA ACHÁ-LO COM FACILIDADE



Parafuso 7,0x40

6º PASSO / STEP / PASO

PEÇAS
PIECES
PIEZAS

S.M.	C.P.
01	9263
02	9277

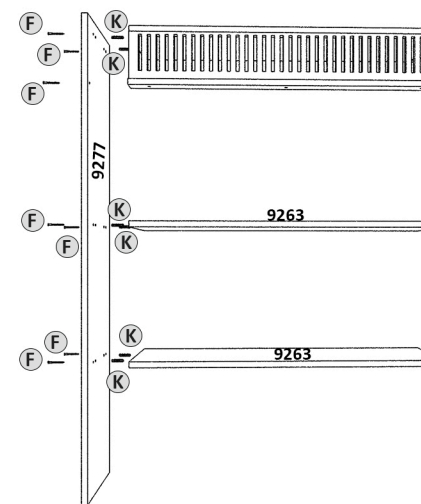

F COLOQUE O PARAFUSO EM CIMA DO DESENHO 6X
PARA ACHÁ-LO COM FACILIDADE



Parafuso 7,0x40

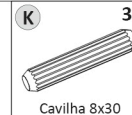

Cavilha 8x30

7º PASSO / STEP / PASO

PEÇAS
PIECES
PIEZAS

S.M.	C.P.
01	9269
02	9279
03	9280

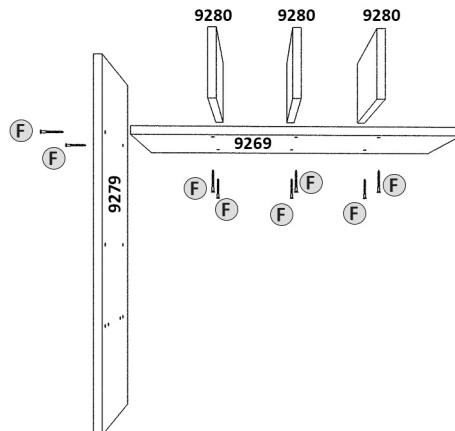

F COLOQUE O PARAFUSO EM CIMA DO DESENHO 8X
PARA ACHÁ-LO COM FACILIDADE



Parafuso 7,0x40

8º PASSO / STEP / PASO

PEÇAS
PIECES
PIEZAS

S.M.	C.P.
01	9266
02	9270

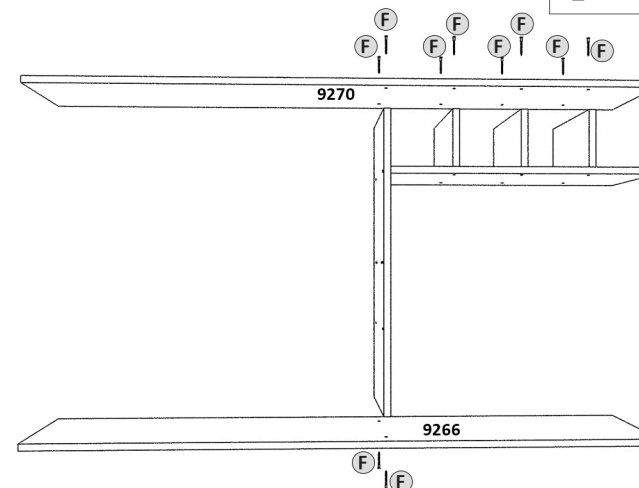

F COLOQUE O PARAFUSO EM CIMA DO DESENHO 8X
PARA ACHÁ-LO COM FACILIDADE



Parafuso 7,0x40

9º PASSO / STEP / PASO

PEÇAS
PIECES
PIEZAS

S.M.	C.P.
01	9267
02	9268
03	9278
04	9281
05	9287

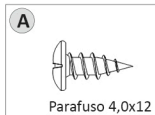
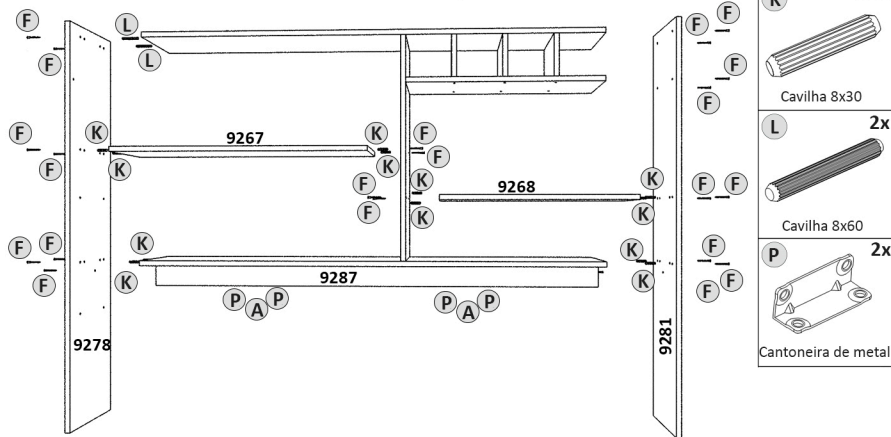

- K 12x
Cavilha 8x30
- L 2x
Cavilha 8x60
- P 2x
Cantoneira de metal

10º PASSO / STEP / PASO

PEÇAS
PIECES
PIEZAS

S.M.	C.P.
------	------

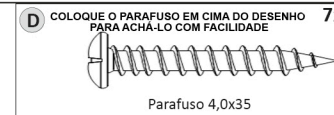
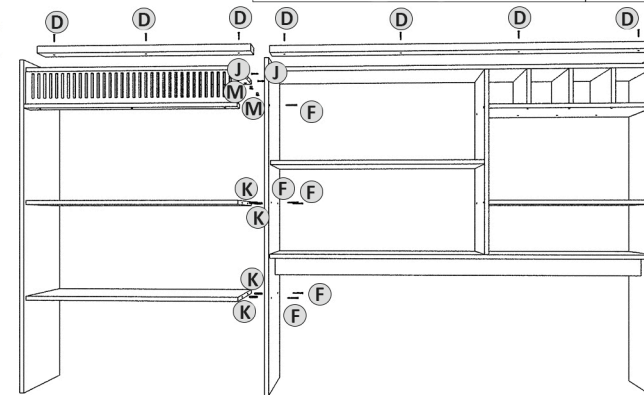

- K 3x
Cavilha 8x30
- J 6x
Pino minifix
- M 2x
Tambor minifix

11º PASSO / STEP / PASO

PEÇAS
PIECES
PIEZAS

S.M.	C.P.
01	9292

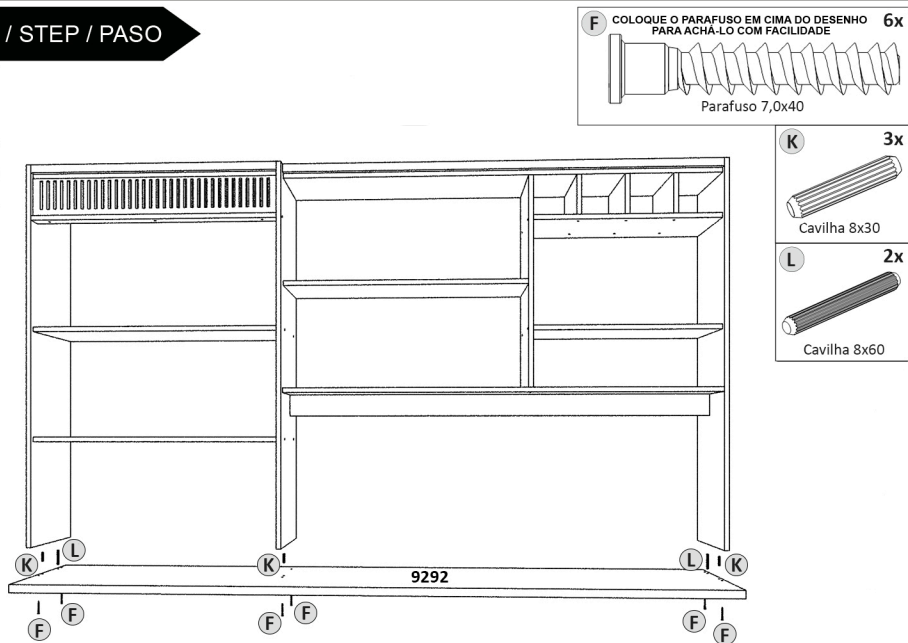

- K 3x
Cavilha 8x30
- L 2x
Cavilha 8x60

12º PASSO / STEP / PASO

PEÇAS
PIECES
PIEZAS

S.M.	C.P.
------	------

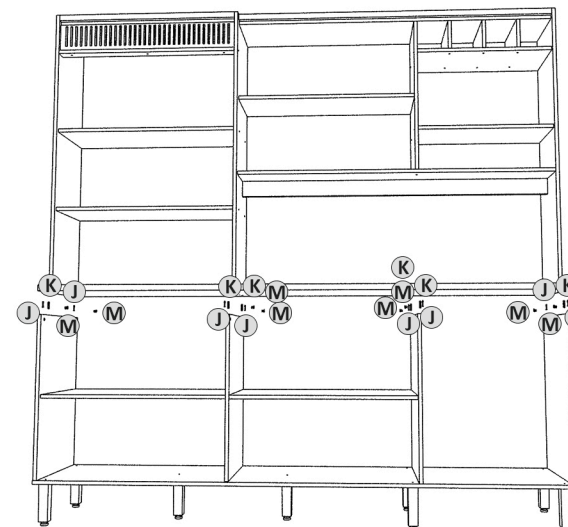

- J 8x
Pino minifix
- K 6x
Cavilha 6x30
- M 8x
Tambor minifix

13° PASSO / STEP / PASO

**PEÇAS
PIECES
PIEZAS**

S.M.	C.P.
01	9296
02	9297
03	9298
04	9299
05	9301

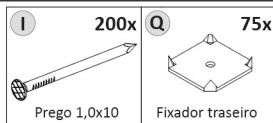
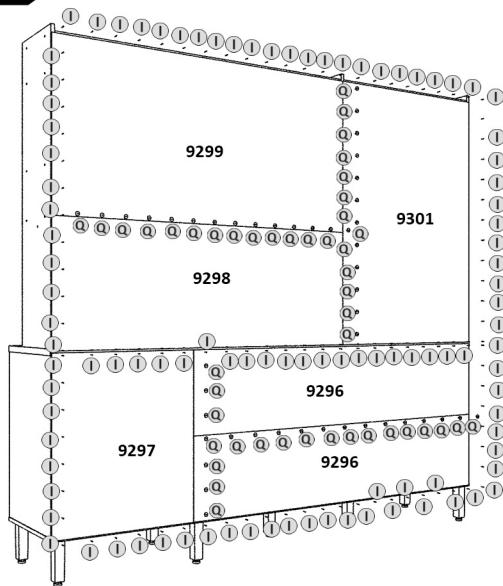

14° PASSO / STEP / PASO

**PEÇAS
PIECES
PIEZAS**

S.M.	C.P.
01	9282
02	9283
03	9284
04	9289
05	9290
06	9291

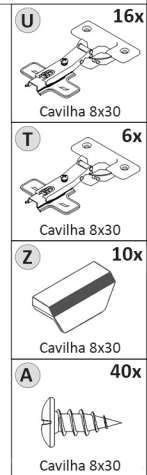
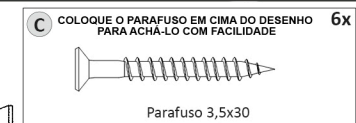
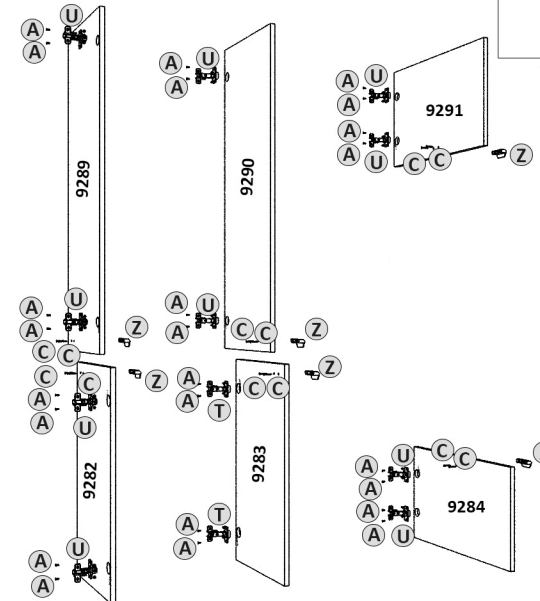

15° PASSO / STEP / PASO

**PEÇAS
PIECES
PIEZAS**

S.M.	C.P.
01	9275
02	9276
03	9285
04	9286
05	9295

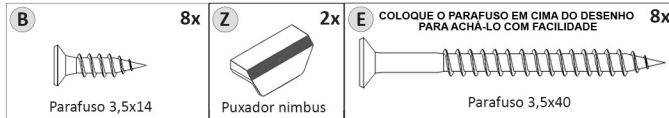
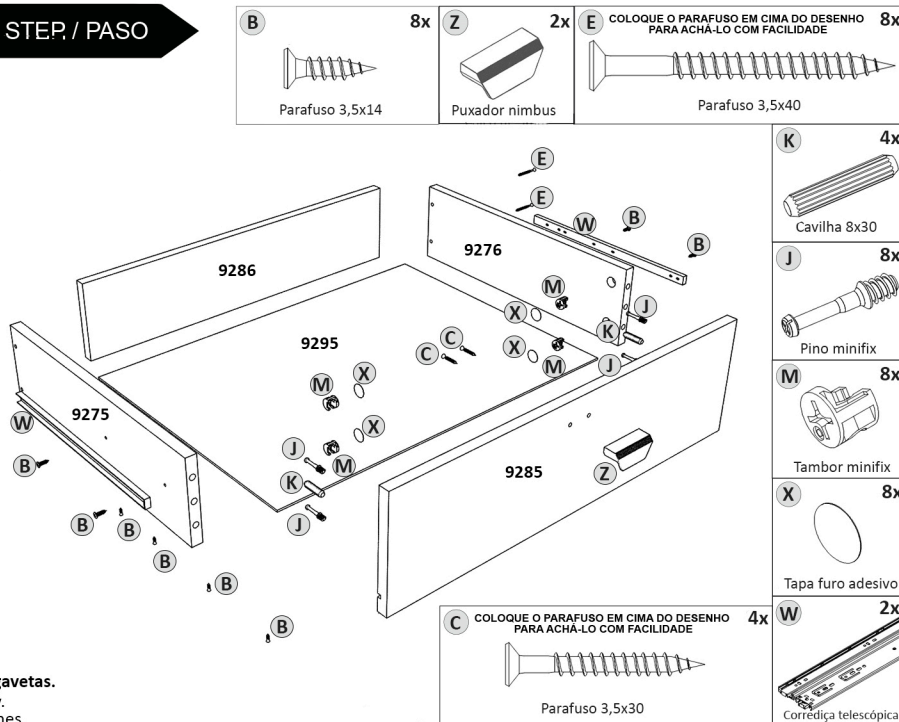

16° PASSO / STEP / PASO

**PEÇAS
PIECES
PIEZAS**

S.M.	C.P.
------	------

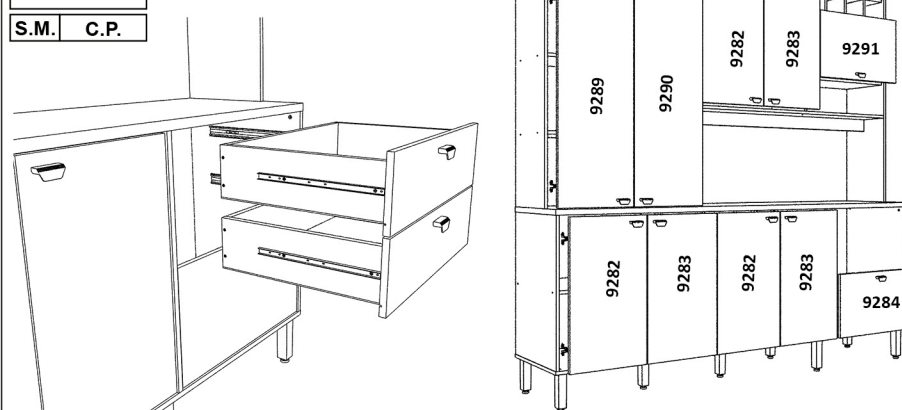

* Montagem das gavetas.
* Drawer assembly.
* Montaje de cajones.