

323 - GR SOLE

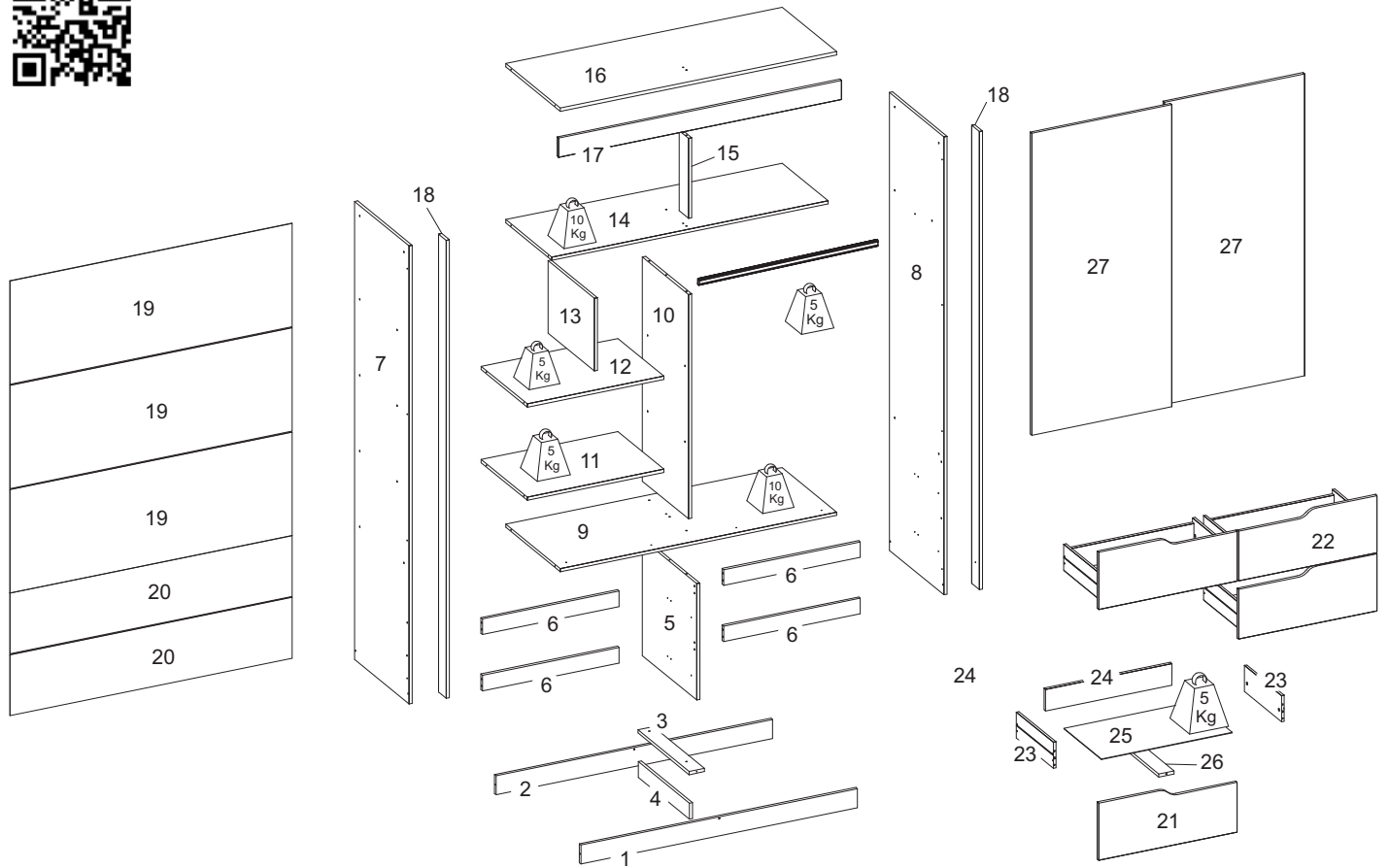

SEQ.	REF.	DESCRIÇÃO	DESCRIPTION	DESCRIPCIÓN	MAT.PRIMA	COMP.	LARG.	ESP.	QTD.
1	332969	Rodapé Frontal	Front skirting board	Zócalo delantero	MDP	1305	88	15	1
2	332970	Rodapé Traseiro	Rear skirting board	Zócalo trasero	MDP	1305	88	15	1
3	332971	Trava Divisória	Dividing board lock	Cerradura del divisor	MDP	483	72	15	1
4	332972	Trava Rodapé	Skirting board lock	Cerradura del zócalo	MDP	483	72	15	1
5	332973	Divisória Menor	Smaller Partition	Partición más pequeña	MDP	528	514	15	1
6	332974	Vista Gaveta	Drawer view	Vista del cajón	MDP	645	72	15	4
7	332975	Lateral Esquerda	Left side	Lado izquierdo	MDP	2120	515	15	1
8	332976	Lateral Direita	Right side	Lado derecho	MDP	2120	515	15	1
9	332977	Tampo Gaveteiro	Drawer top	Parte superior del cajón	MDP	1305	515	15	1
10	332978	Divisória Maior	Larger Partition	Divisor mayor	MDP	1048	435	15	1
11	332979	Prateleira	Shelf	Estante	MDP	645	435	15	1
12	332980	Prateleira Nicho	Niche Shelf	Nicho para estante	MDP	645	435	15	1
13	332981	Divisória Nicho	Niche Divider	Separador de nicho	MDP	435	336	15	1
14	332982	Base Maleiro	Hat Rack Base	Base de armario	MDP	1305	435	15	1
15	332983	Batente Frontal	Front Stopper	Tope frontal	MDP	371	88	15	1
16	332984	Chapéu	Hat	Sombrero	MDP	1305	515	15	1
17	332985	Vista Superior	Top view	Vista superior	MDP	1335	88	15	1
18	332986	Vista Lateral	Side view	Vista lateral	MDP	2120	72	15	2
19	332987	Fundo	Bottom	Parte inferior	HDF	1331	481	3	3
20	332988	Fundo Menor	Smaller Farm	Fondo Menor	HDF	1331	276	3	2
21	332989	Frente De Gaveta Esquerda	Left drawer front	Frente del cajón izquierdo	MDP	653	264	15	2
22	332990	Frente De Gaveta Direita	Right drawer front	Frente del cajón derecho	MDP	653	264	15	2
23	332991	Lateral De Gaveta	Drawer side	Lateral del cajón	MDP	350	120	12	8
24	332992	Contra Fundo	Countertop	Encimera	MDP	596	100	15	4
25	332993	Fundo Da Gaveta	Drawer bottom	Parte inferior del cajón	HDF	618	355	3	4
26	332994	Apoio De Gaveta	Drawer Support	Soporte para cajones	MDP	350	72	15	4
27	332995	Porta De Correr	Running Gate	Puerta corredera	MDP	1408	661	15	2

INSTRUÇÃO MONTAGEM PRODUTO

Instructions to Assembly / Instrucciones de montaje

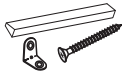

Separe as peças e acessórios de maneira organizada
Separate parts and accessories in way organized
Separe las piezas y accesorios de manera organizada

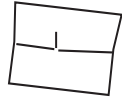

Forrar o chão com o papelão das embalagens.
Cover the floor with the cardboard
Cubra el suelo con la embalaje de cartón



É necessário 01 pessoa para montar o produto
01 people are required to assemble the product
Se requieren 01 persona para ensamblar el producto

O produto deve ser a montado por um profissional qualificado
The product must be assembly by a professional
El producto debe ser ensamblado por un profesional calificado

Ferramentas necessárias
(não fornecidas)
Not include tools / No herramientas



CUIDADO PARA CONSERVAÇÃO E LIMPEZA DO MÓVEL

Care to conservation and clean / Cuidados de limpieza

Peso máximo de carga informado refere-se a objetos distribuído de maneira uniforme sobre toda área de contato da peça



The maximum load weight informed refers to objects distributed evenly over the entire contact area of the part
Conjunto de carga máxima de peso se refere a objetos distribuídos uniformemente sobre toda el área de contacto de la pieza de trabajo.



Não molhar o móvel e não expor em lugar úmido
Do not wet the mobile and do not expose in a wet place
No moje el producto y no exponer en un lugar húmedo



Não expor o móvel próximo de fontes de calor.
Do not expose the mobile near heat sources
no exponga cercano de fuentes de calor



Não usar produtos abrasivos.
Do not use abrasive products.
No utilice productos abrasivos.



Limpe com flanela limpa e seca.
Clean with dry cloth
Limpieza con un paño limpio y seco



Para limpar os carimbos das peças utilize uma borracha escolar (item não fornecido)
Para clean the stamps on the pieces use a school eraser (item not provided)
Para limpiar los sellos de las piezas utilice un borrador escolar (artículo não incluido)

LISTA DE ACESSÓRIOS E FERRAGENS / ACCESSORIES AND HARDWARE / ACCESORIOS Y HARDWARE



A- 700542-Cavilha 6x30 (22x)
peg / cerrojo



B- 700543-Cavilha 6x60 (07x)
peg / cerrojo



C - 700137-Parafuso 4,5x45 (38x)
screw / tornillo



D- 700124-Parafuso 3,5x25 (28x)
screw / tornillo



E- 700121-Parafuso 3,5x12 (180x)
screw / tornillo



F- 700123-Parafuso 3,5x22 (4x)
screw / tornillo



G - 700539-Cantoneira metálica
4 furos (11x)
corner / esquina



H- 700446-Porca cilíndrica (08x)
Cylindrical Nut /
Tuerca cilíndrica



I- 700146 - Parafuso minifix (11x)
Minifix screw / Tornillo minifix



J- 700148 -Tambor Minifix (11x)
Minifix Drum / Tambor minifix



K- 700157-Prego (150x)
nail / clavo



L-700438-Suporte cabide (02X)
hook support / soporte gancho



M - 703785 - Bastão Alumínio (01x)
Coat Rack / Perchero



N- 700182-Puxador (2X)
sliding / manija

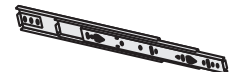

O- 700113-Corrediça (04x)
runners / corredera



P - 700490 - Kit com 6 Pes (1x)
foot / pie



Q - 700433-Suporte angular (6x)
Angled support / Soporte en ángulo



R - 703784 - Perfil H (03x)
Frame / Perfil



S - 703783 - Trilho superior (1x)
top rail / carril superior

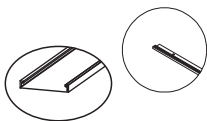

T - 703782 -Trilho inferior (1x)
Bottom rail / Riel inferior



U- 703781-Kit porta correr (02x)
bearing kit / kit de rodamientos



V- 700547-Junção (07x)
junction / junction



W - 700565-Gota Silicone (12x)
wood support / Bastón



X- 700419 - Tapa furo minifix (55x)
minifix cover / tapa minifix



Y - 700516 - Sache cola 20g (01x)
Glue / Goma

01° PASSO - Fazer a separação das corredeira

01° STEP - Separate the slides

01° PASO - Separar las diapositivas

O

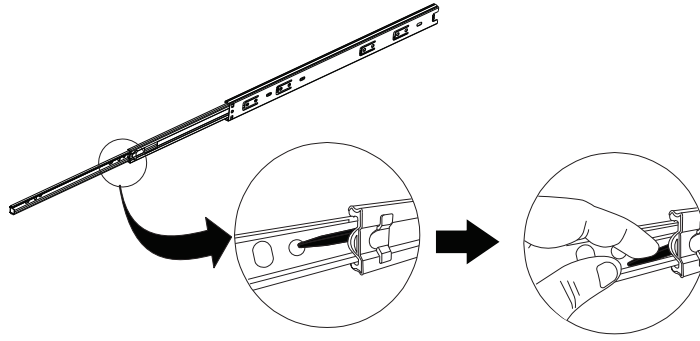

**Abaixe a alça preta e retire a peça conforme abaixo.
Push the black pin down to remove the D1 part.
Empujar para abajo la pieza negra para retirar la parte D1.**

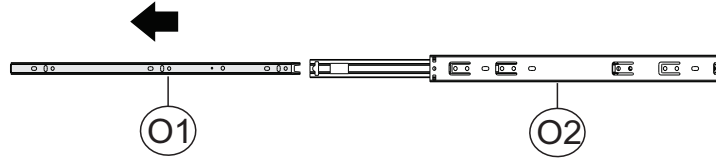

02° PASSO - Fixar os acessórios nas peças 5,7,8.

02° STEP - Fix the accessories to parts 5,7,8.

02° PASO - Fijar los accesorios a las piezas 5,7,8.

B



E



O2

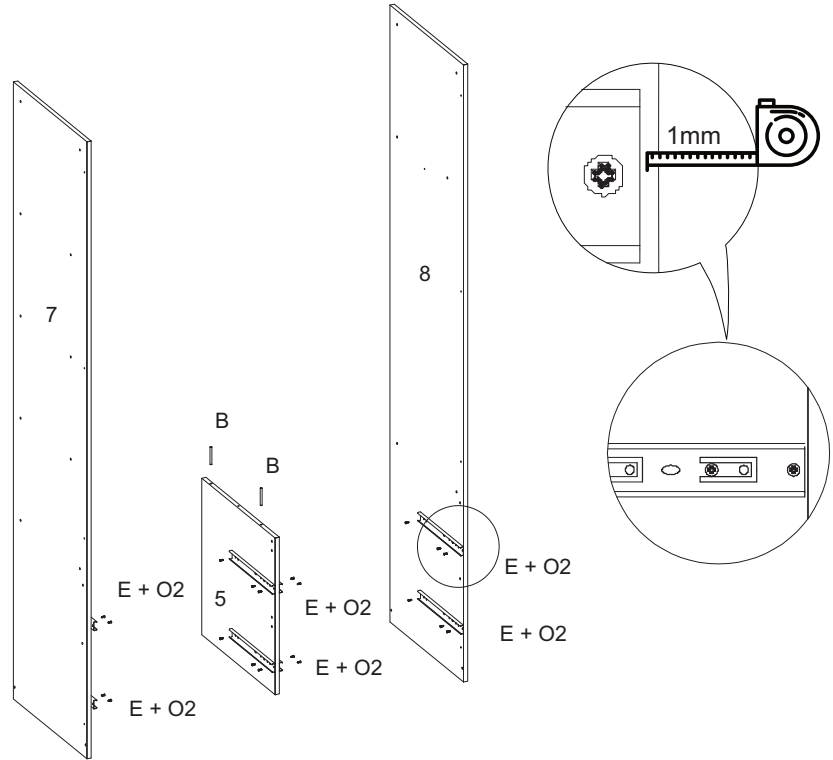
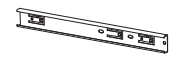

03° PASSO - Fixar peças 1 e 2 na peça 3.

03° STEP - Fix parts 1 and 2 to part 3.

03° PASO - Fijar las piezas 1 y 2 a la pieza 3.

C

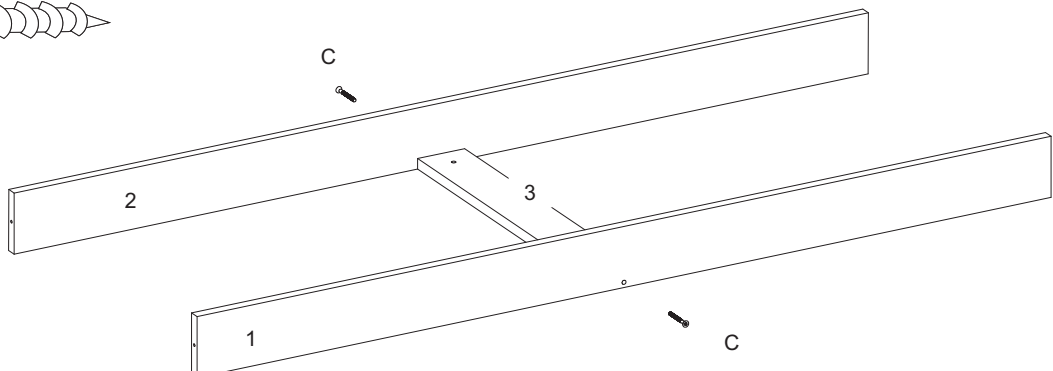
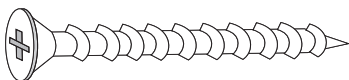

04° PASSO - Fixar peça 4 nas peças 1 e 2.

04° STEP - Fix part 4 to parts 1 and 2.

04° PASO - Fijar la pieza 4 a las piezas 1 y 2.

E



G

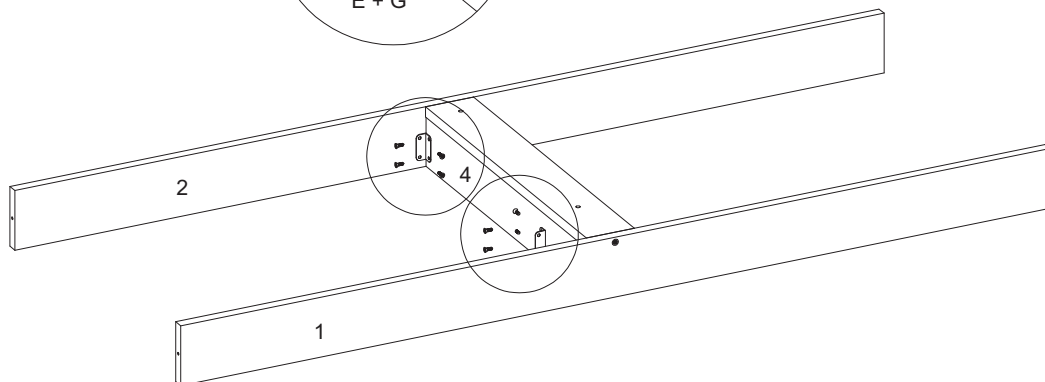
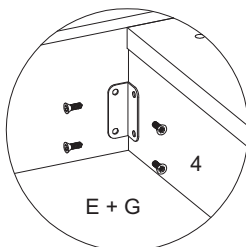

05° PASSO - Fixar os acessórios nas peças 1,2,3,4.

05° STEP - Fix the accessories to the parts 1,2,3,4.

05° PASO - Fijar los accesorios en las piezas 1,2,3,4.

E

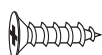

G



P

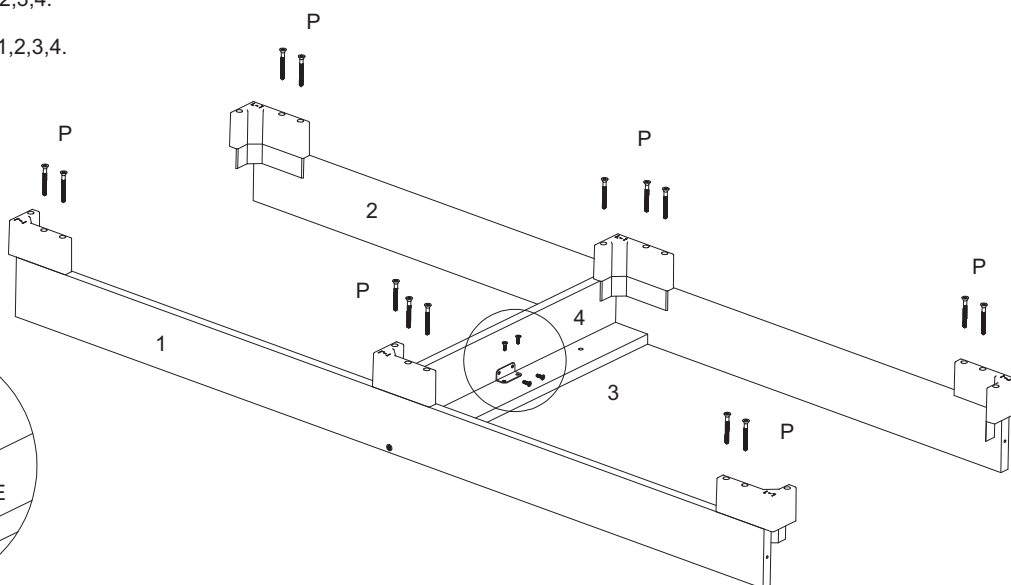
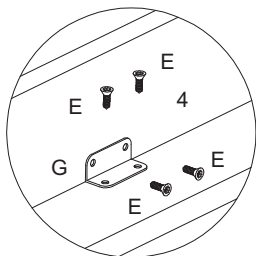

06° PASSO - Fixar a peça 5 na peça 3.

06° STEP - Fijar la pieza 5 a la pieza 3.

06° PASO - Fix part 5 to part 3.

C

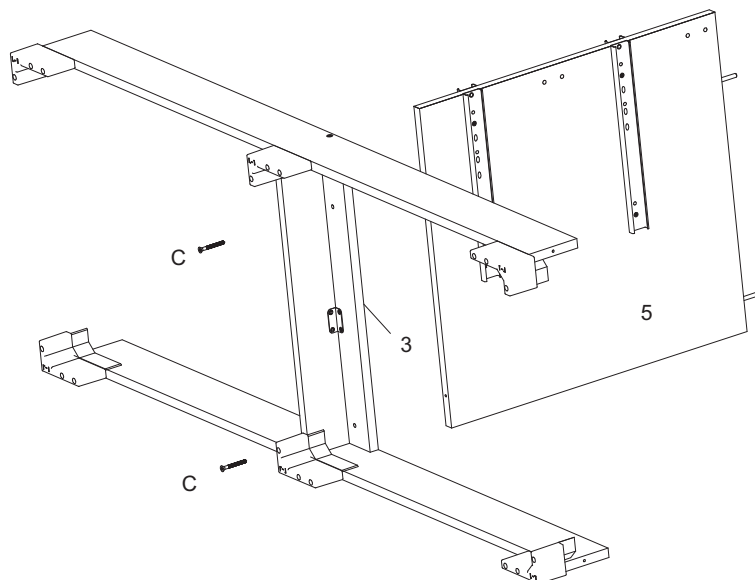

07° PASSO - Fixar peça 7 nas peças 1 e 2, e peça 6 nas peças 5 e 7.

07° STEP - Fix part 7 to parts 1 and 2, and part 6 to parts 5 and 7.

07° PASO - Fijar la pieza 7 a las piezas 1 y 2, y la pieza 6 a las piezas 5 y 7.

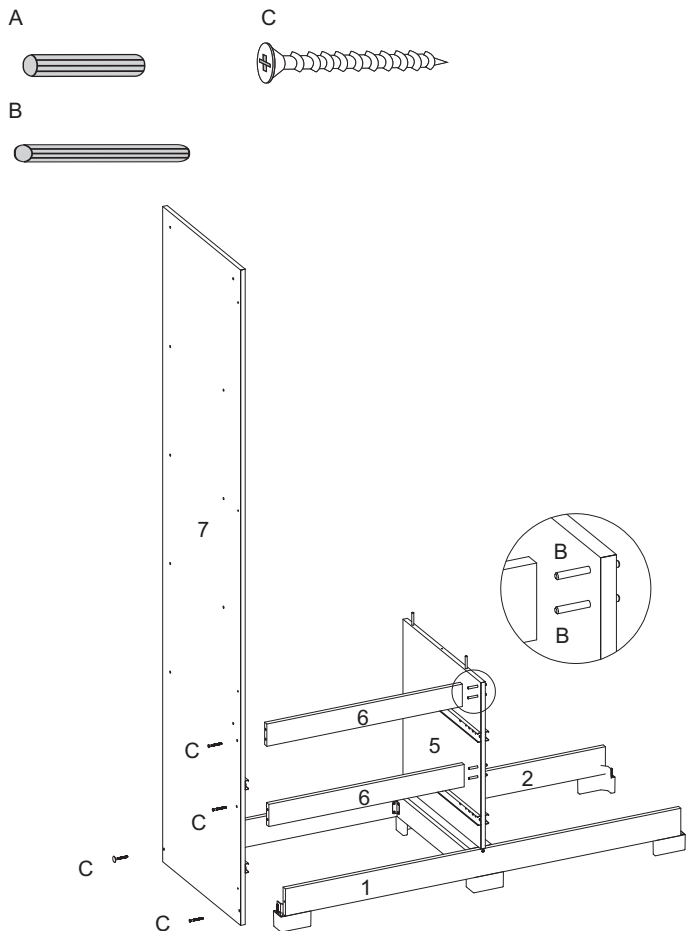

08° PASSO - Fixar peça 8 nas peças 1 e 2, e peça 6 nas peças 5 e 8.

08° STEP - Fix part 8 to parts 1 and 2, and part 6 to parts 5 and 8.

08° PASO - Fijar la pieza 8 a las piezas 1 y 2, y la pieza 6 a las piezas 5 y 8.

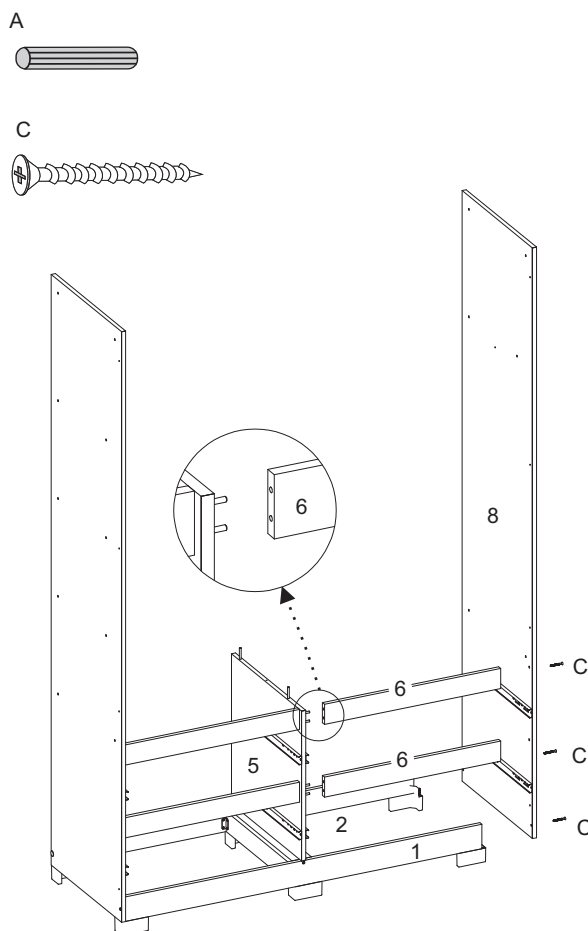

09° PASSO - Fixar os acessórios nas peças 5,6,7,8.

09° STEP - Fix the accessories to parts 5, 6, 7, and 8.

09° PASO - Fijar los accesorios en las piezas 5, 6, 7 y 8.

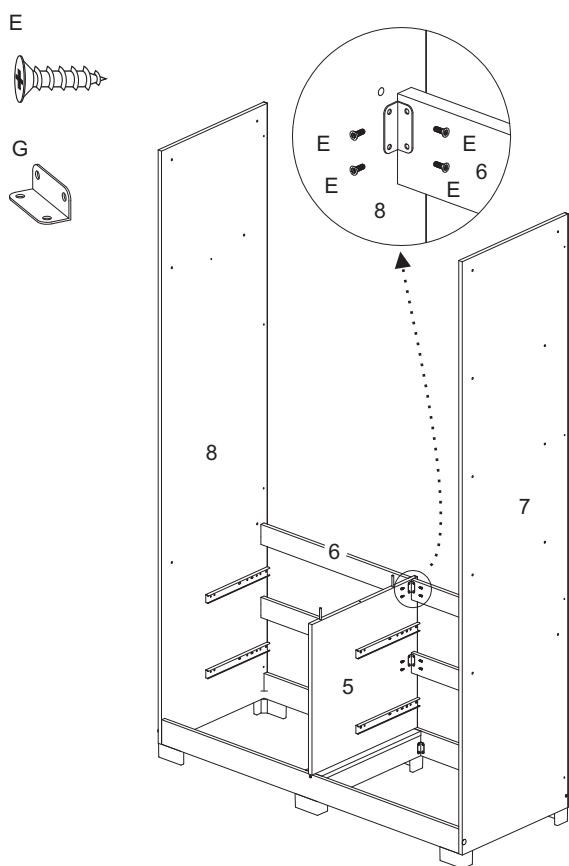

10° PASSO - Fixar peça 9 nas peças 5, 7 e 8.

10° STEP - Fix part 9 to parts 5, 7, and 8.

10° PASO - Fijar la pieza 9 a las piezas 5, 7 y 8.

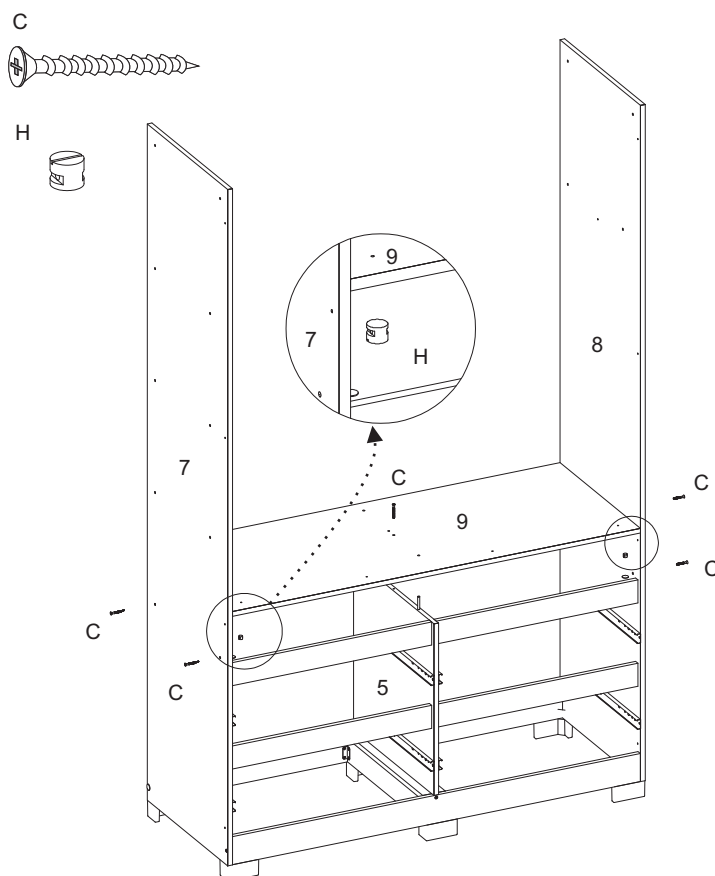

11° PASSO - Fixar peça 10 na peça 9.

11° STEP - Fix part 10 to part 9.

11° PASO - Fijar la pieza 10 a la pieza 9.

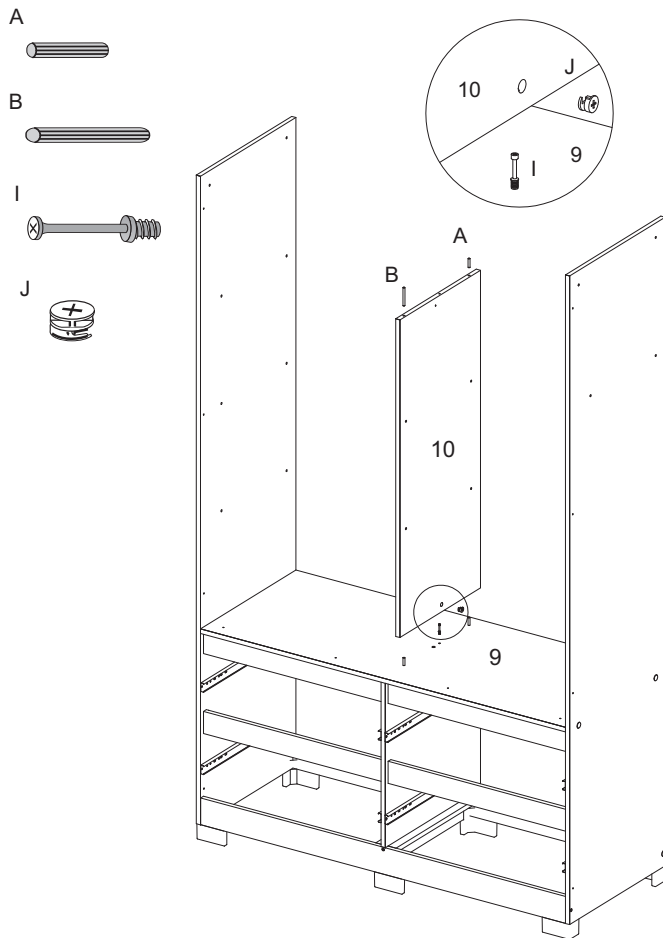

12° PASSO - Fixar as peças 11,12 nas peças 7 e 10.

12° STEP - Fix parts 11 and 12 to parts 7 and 10.

12° PASO - Fijar las piezas 11 y 12 a las piezas 7 y 10.

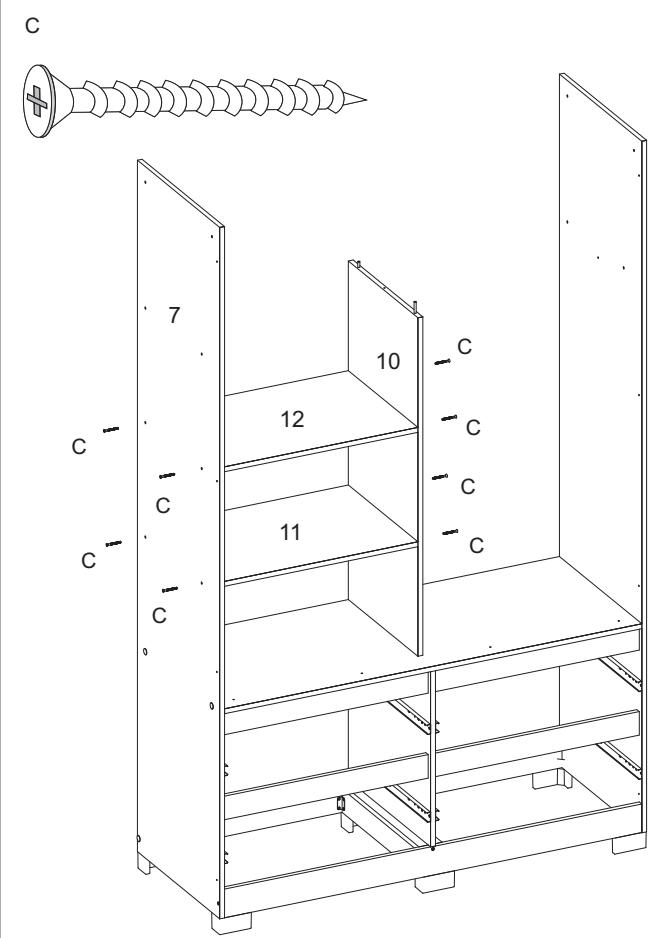

13° PASSO - Fixar peça 13 nas peças 7,8,10,13.

13° STEP - Fix part 13 to part 12.

13° PASO - Fijar la pieza 13 a la pieza 12.

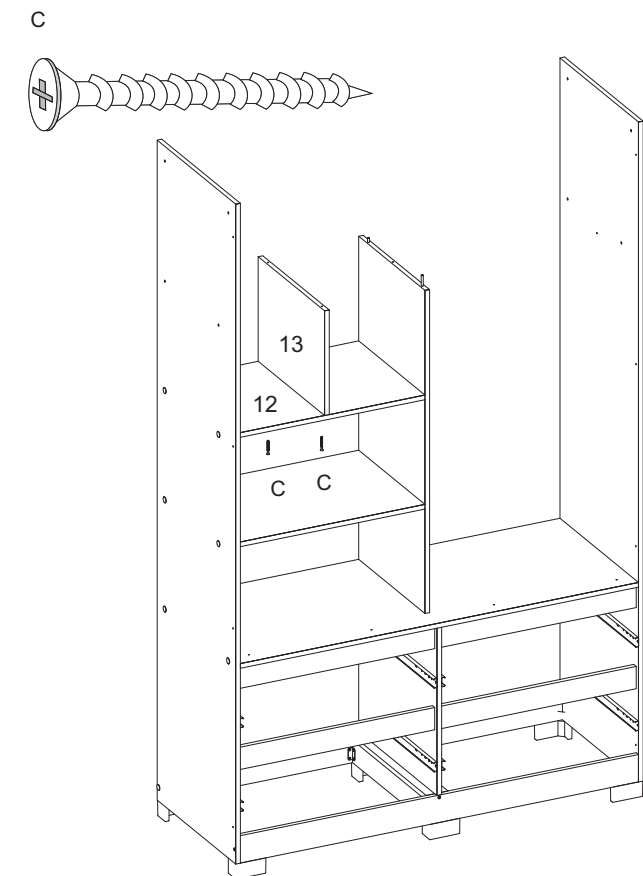

14° PASSO - Fixar peça 14 nas peças 7,8,10,13.

14° STEP - Fix part 14 to parts 7, 8, 10, and 13.

14° PASO - Fijar la pieza 14 a las piezas 7, 8, 10 y 13.

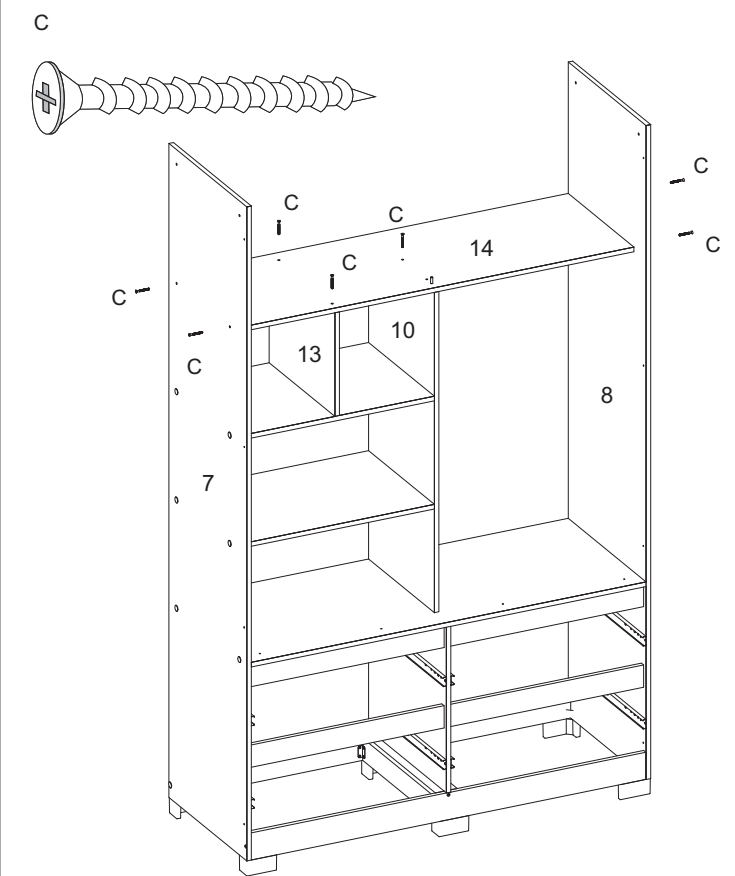

15° PASSO - Fixar peça 15 na peça 14.

15° STEP - Fix part 15 to part 14.

15° PASO - Fijar la pieza 15 a la pieza 14.

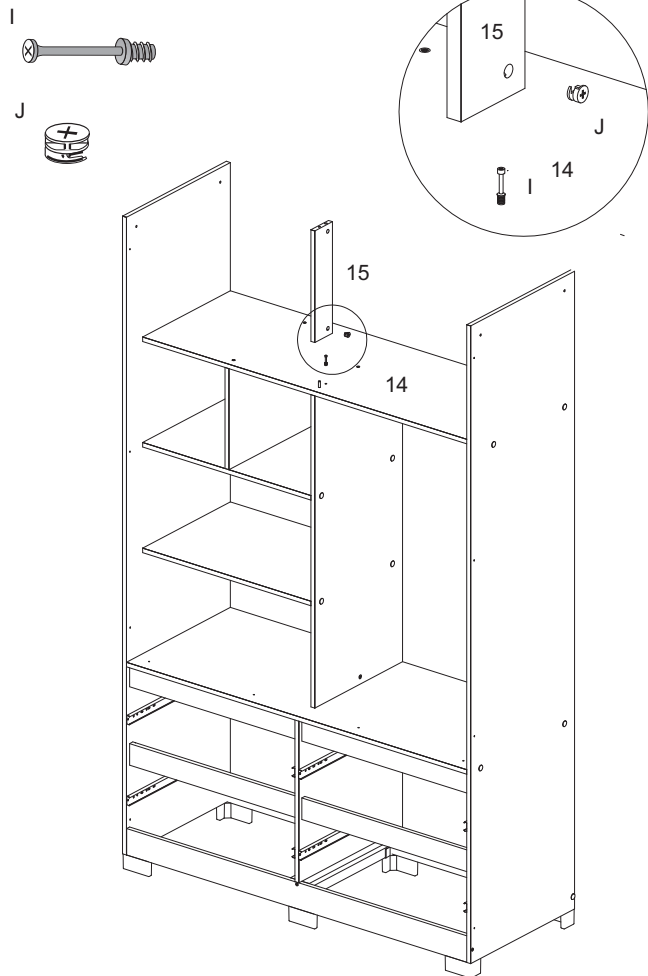

16° PASSO - Fixar peça 16 nas peças 7,8 e 15.

16° STEP - Fix part 16 to parts 7, 8, and 15.

16° PASO - Fijar la pieza 16 a las piezas 7, 8 y 15.

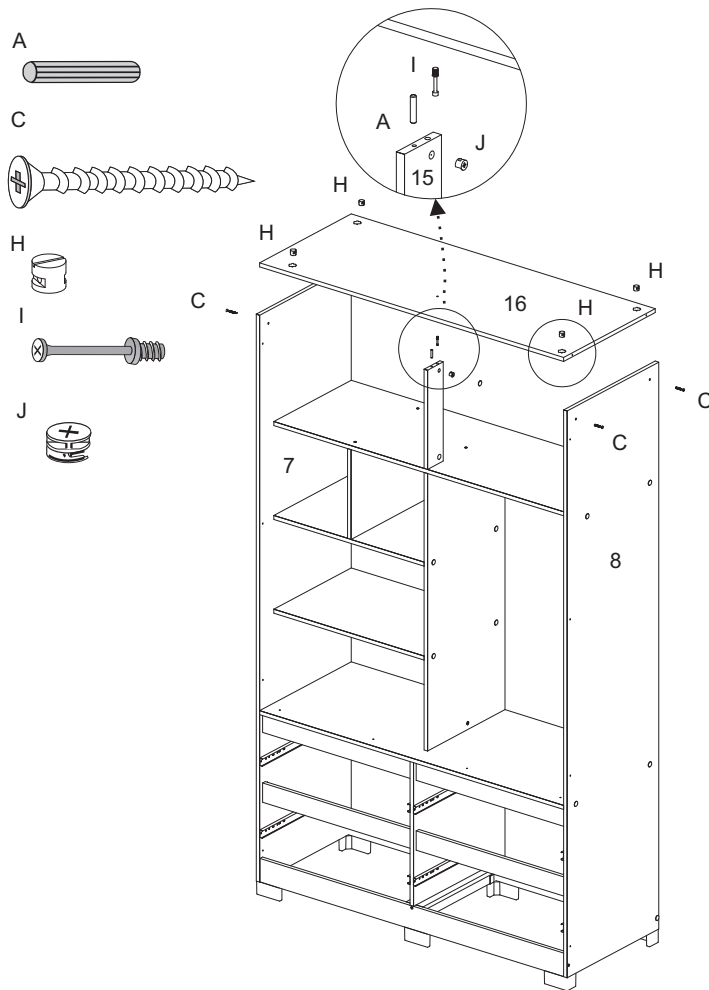

17° PASSO - Fixar peça 17 nas peças 7,8 e 16.

17° STEP - Fix part 17 to parts 7, 8, and 16.

17° PASO - Fijar la pieza 17 a las piezas 7, 8 y 16.

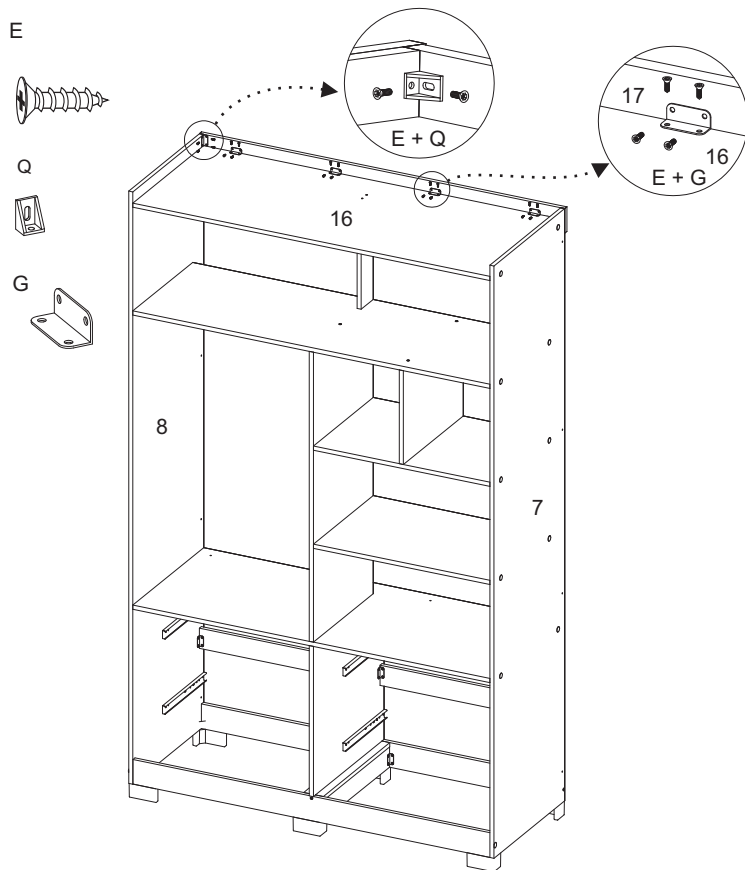

18° PASSO - Fixar peça 18 nas peças 7 e 8.

18° STEP - Fix part 18 to parts 7 and 8.

18° PASO - Fijar la pieza 13 a las piezas 8 y 12.

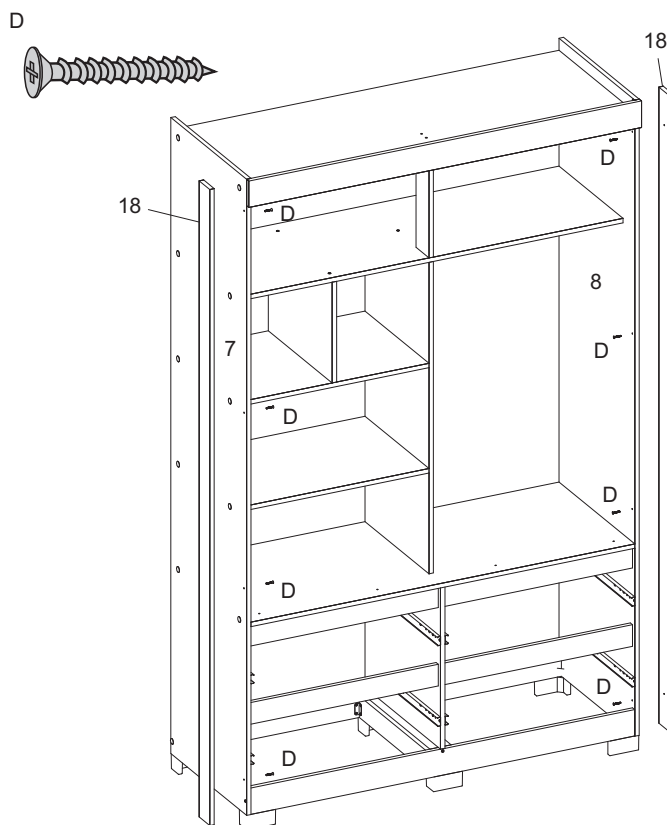

19° PASSO - Fixar as peças 19 e 20 atrás do produto.

19° STEP - Fix parts 19 and 20 to the back of the product.

19° PASO - Fijar las piezas 19 y 20 detrás del producto.

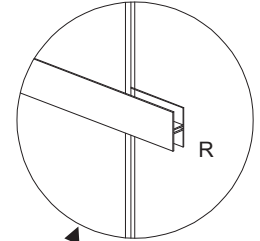
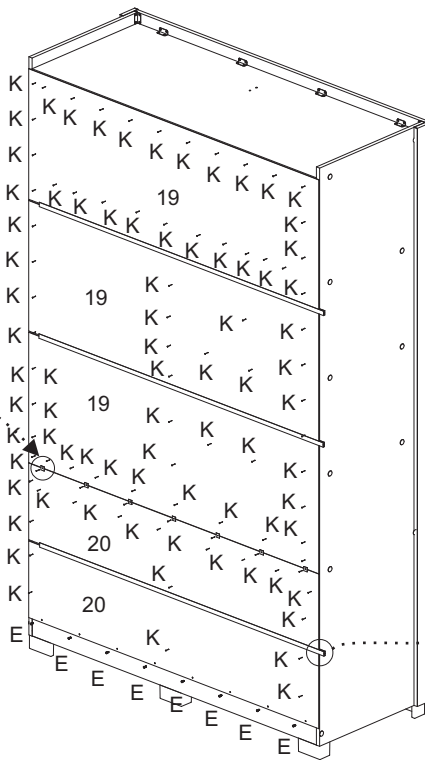
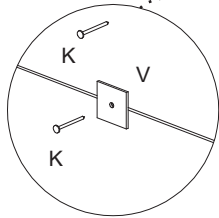

20° PASSO - Fixar os acessórios na peças 8 e 10.

20° STEP - Fix the accessories to parts 8 and 10.

20° PASO - Fijar los accesorios en las piezas 8 y 10.

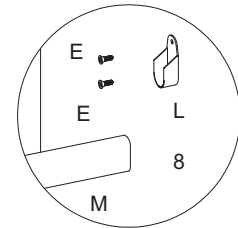
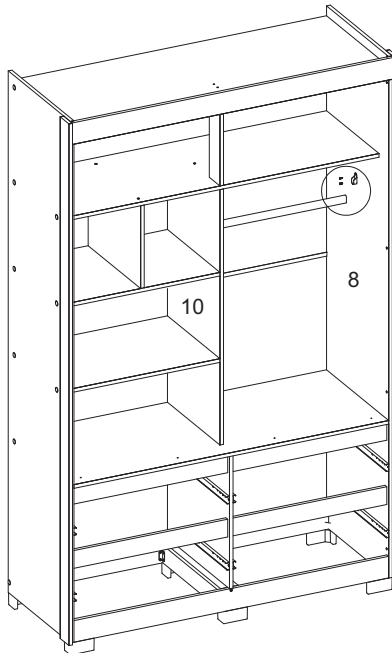
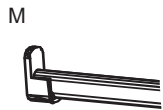

21° PASSO - Fixar peças 23 nas peças 21,22 e 24.

21° STEP - Fix parts 23 to parts 21,22 and 24.

21° PASO - Fijar las partes 23 con las partes 21,22 y 24.

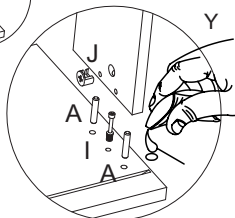
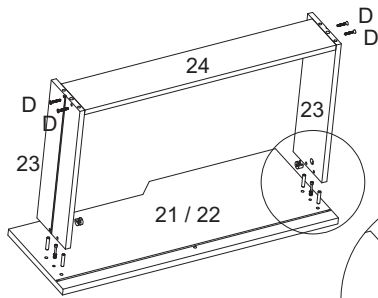
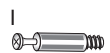

22° PASSO - Fixar peça 25 nas peças 23 e 24.

22° STEP - Fix part 25 to parts 23 and 24.

22° PASO - Fijar la pieza 25 a las piezas 23 y 24.

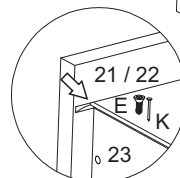
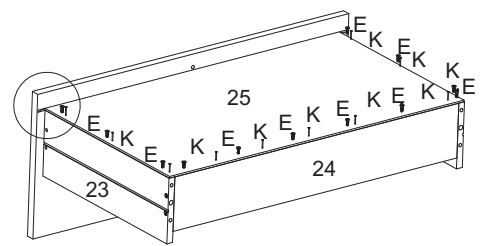

23° PASSO - Fixar peça 26 nas peças 21,22,24 e 25.

23° STEP - Fix part 26 to parts 21, 22, 24, and 25.

23° PASO - Fijar la pieza 26 a las piezas 21, 22, 24 y 25.

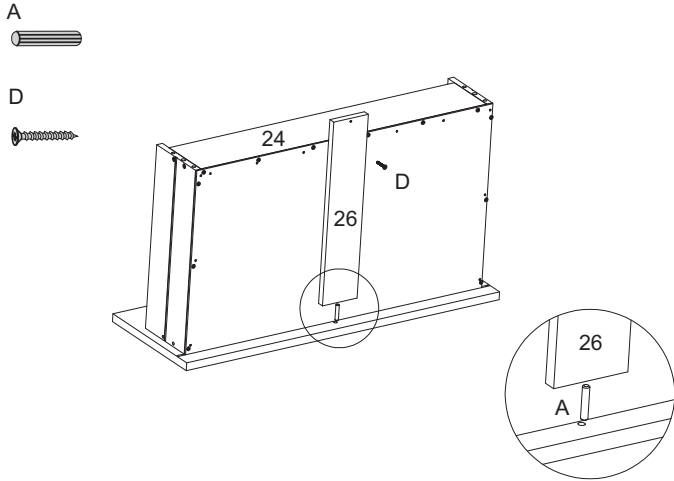

24° PASSO - Fixar o acessórios (E + O1) nas peças 23

24° STEP - Fix the accessories (E + O1) to the parts 23

24° PASO - Fijar los accesorios (E + O1) en las piezas 23

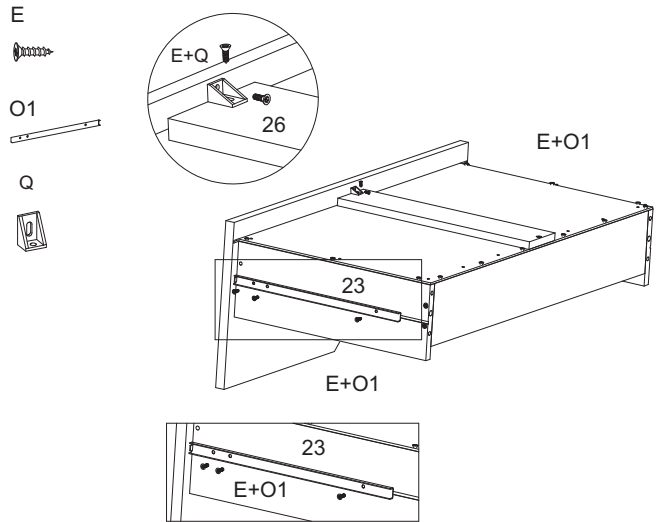

25° PASSO - Fixar os acessórios nas peças 9 e 16.

25° STEP - Fix the accessories to parts 9 and 16.

25° PASO - Fijar los accesorios en las piezas 9 y 16.

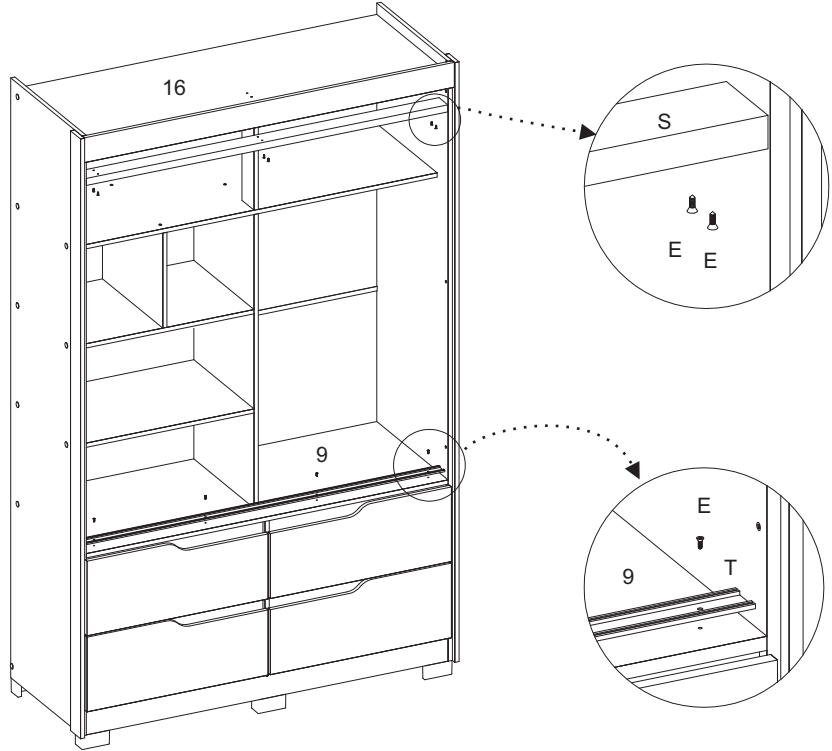
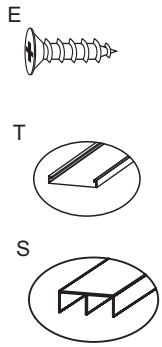

26° PASSO - Fixar os acessórios nas peças 27.

26° STEP - Fix the accessories to parts 27.

26° PASO - Fijar los accesorios en las piezas 27.

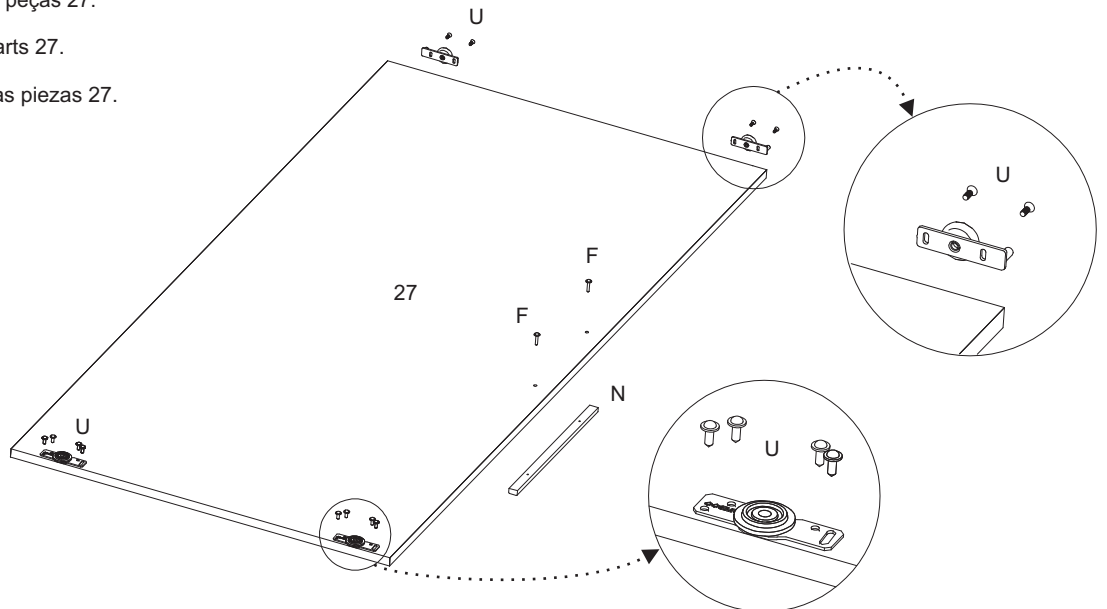
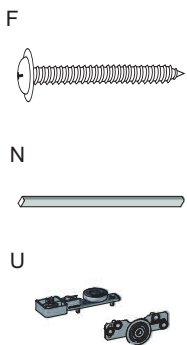

27° PASSO - Encaixar as peças 27 no produto.

27° STEP - Fit parts 27 into the product.

27° PASO - Encajar las piezas 27 en el producto.

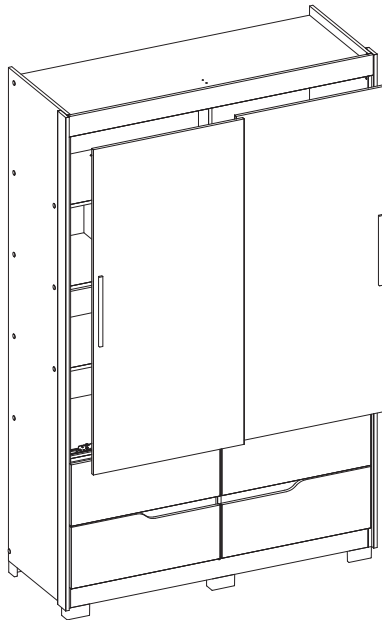

Montagem para o produto que coteem espelhos
Assembly for products with mirrors
Montaje para productos con espejos

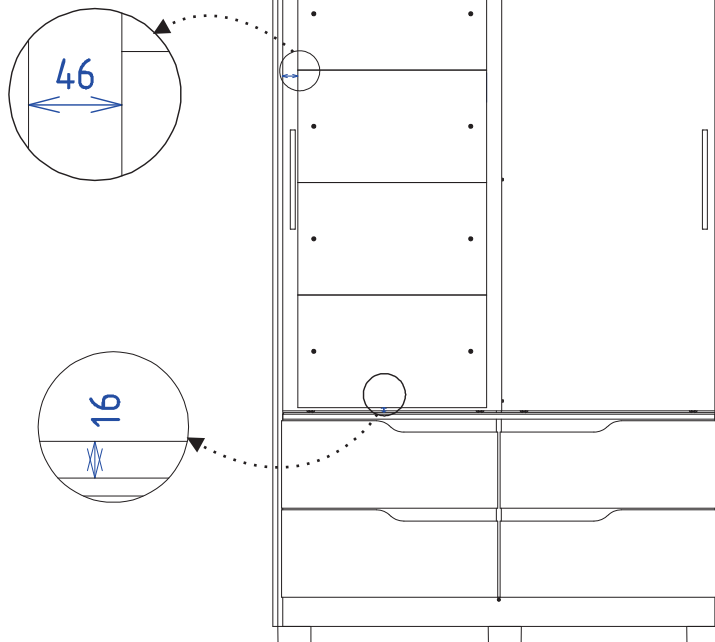

Aspecto final do produto

Final appearance of the product

Aspecto final del producto.

