

Manual de Instruções

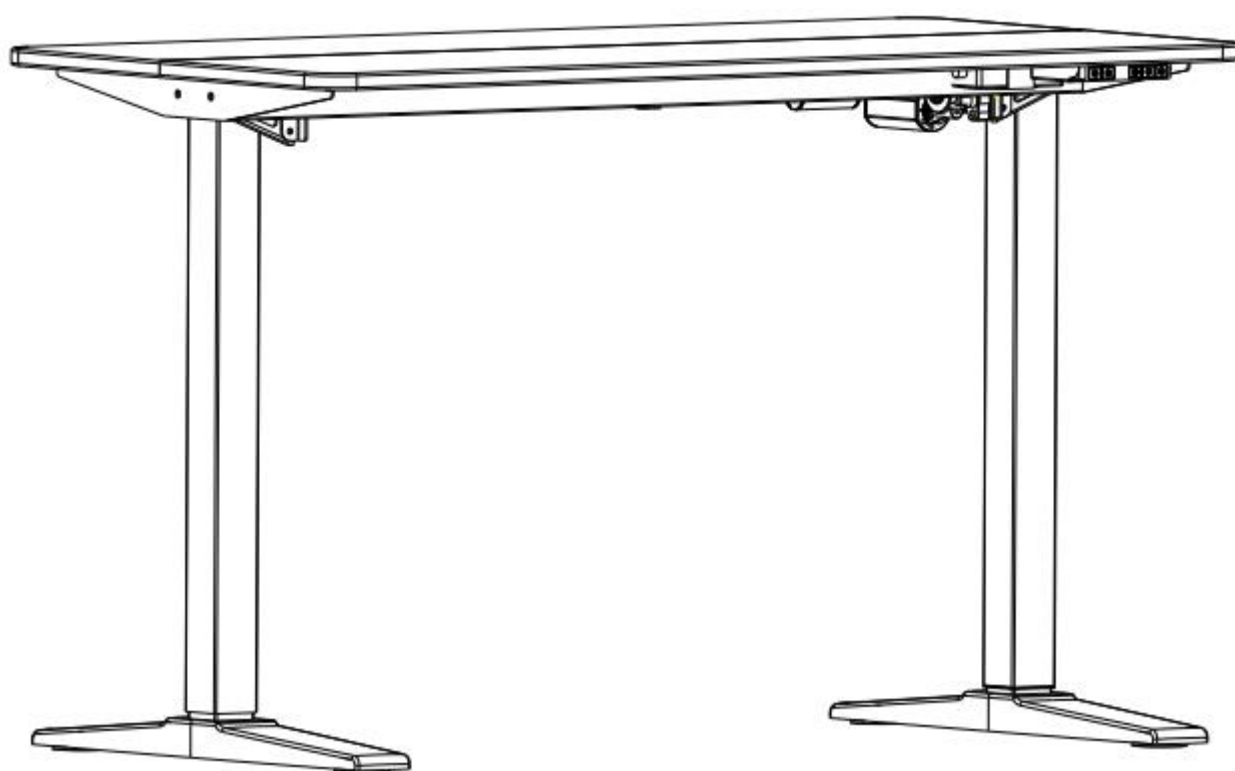

Two-person Assembly

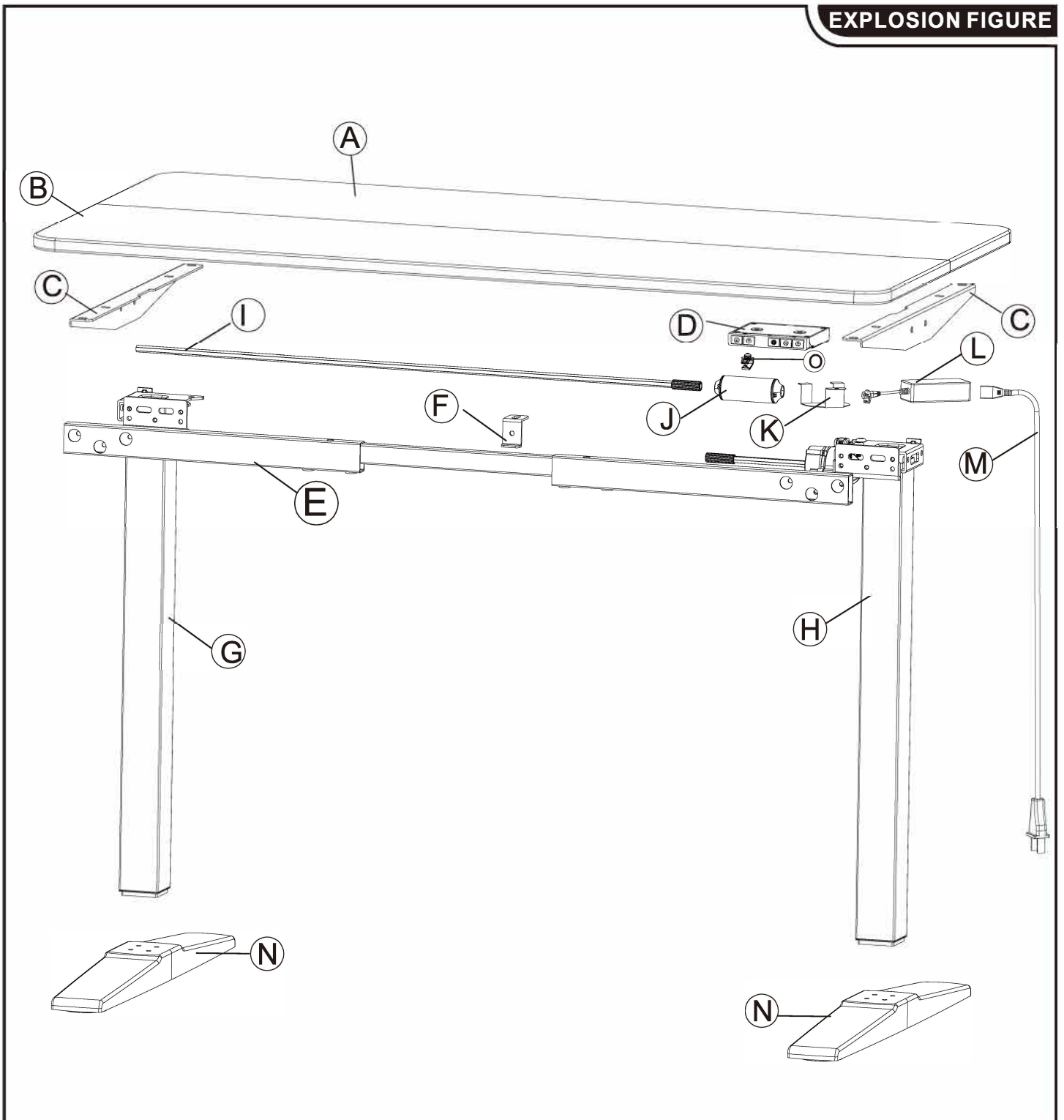

Voltagem de entrada	100-240	V
Voltagem AC de frequência	50/60	Hz
Voltagem de saída	DC29	V
Corrente de saída	1.8	A
Força de saída	52.2	W
Eficiência ativa média	30	%
Eficiência com carga baixa(10 %)	20	%
Consumo de energia sem carga	0.5	W

A x1



B x1

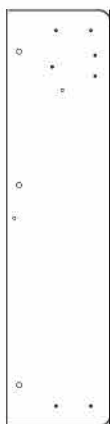

C x2



D x1

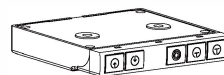

E x1



F x1

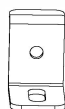

G x1



H x1

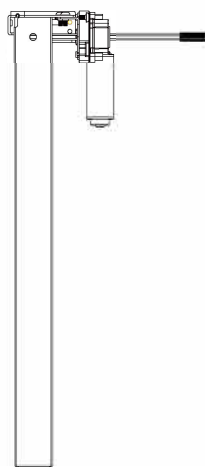

I x1



J x1



K x1

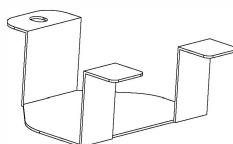

L x1

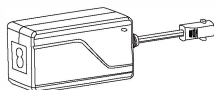

M x1

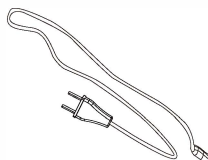

N x2



O x1

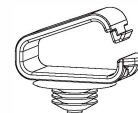

P x5



Q x3



R x6



S x33

+2 (spare)



T x1

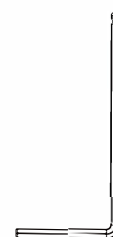

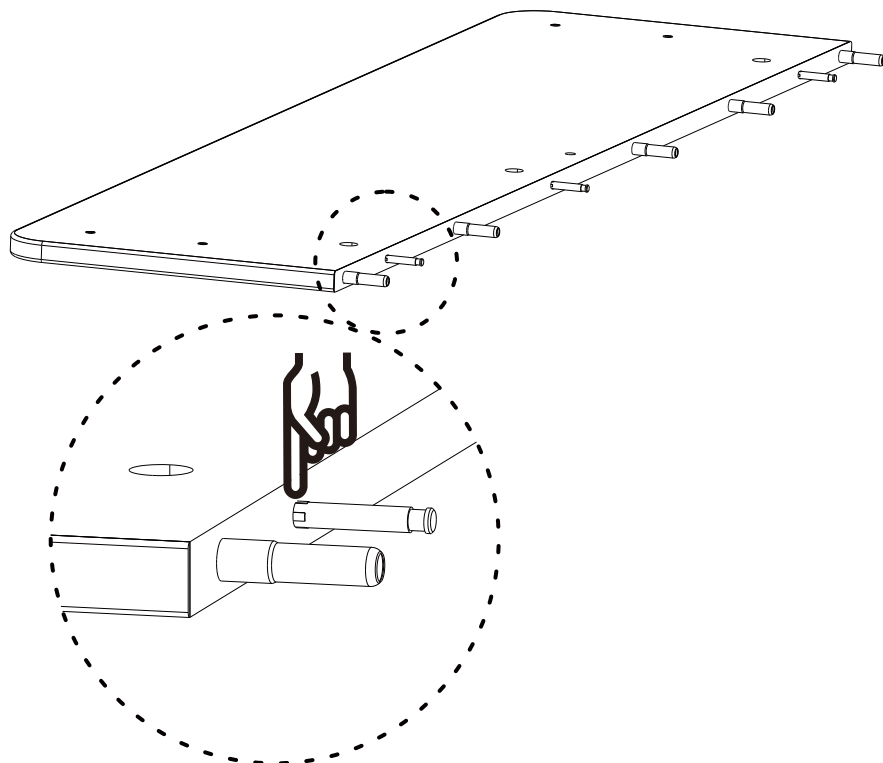
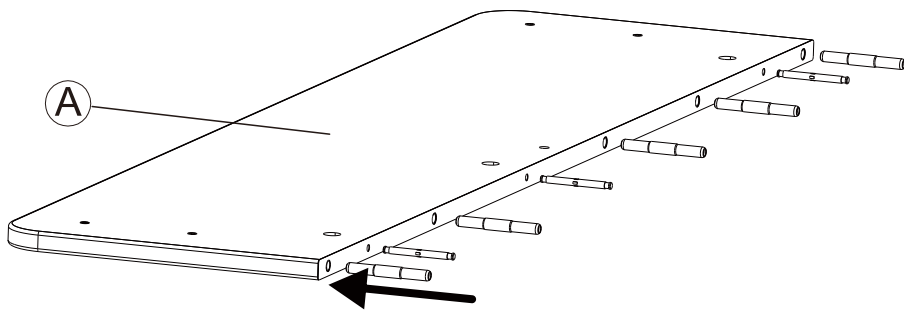
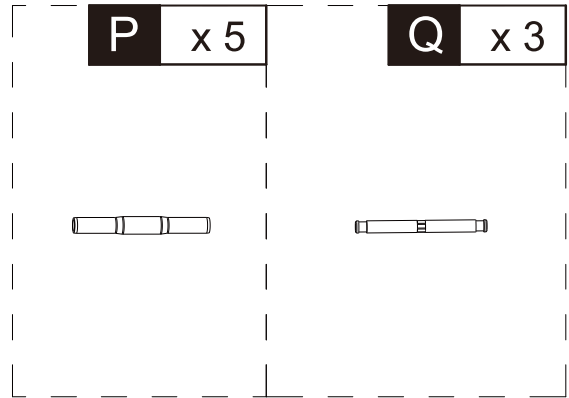

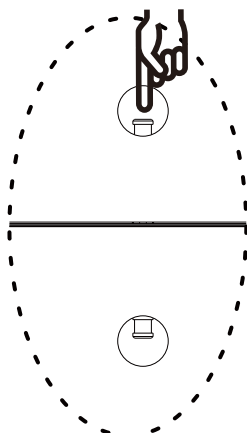
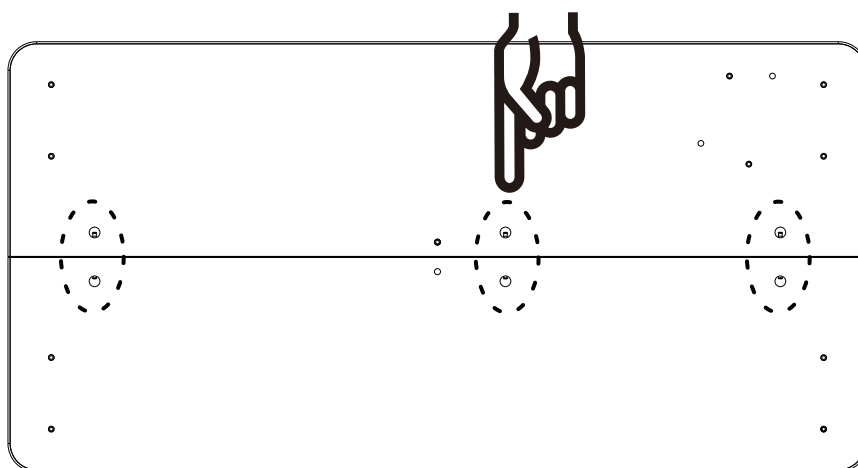
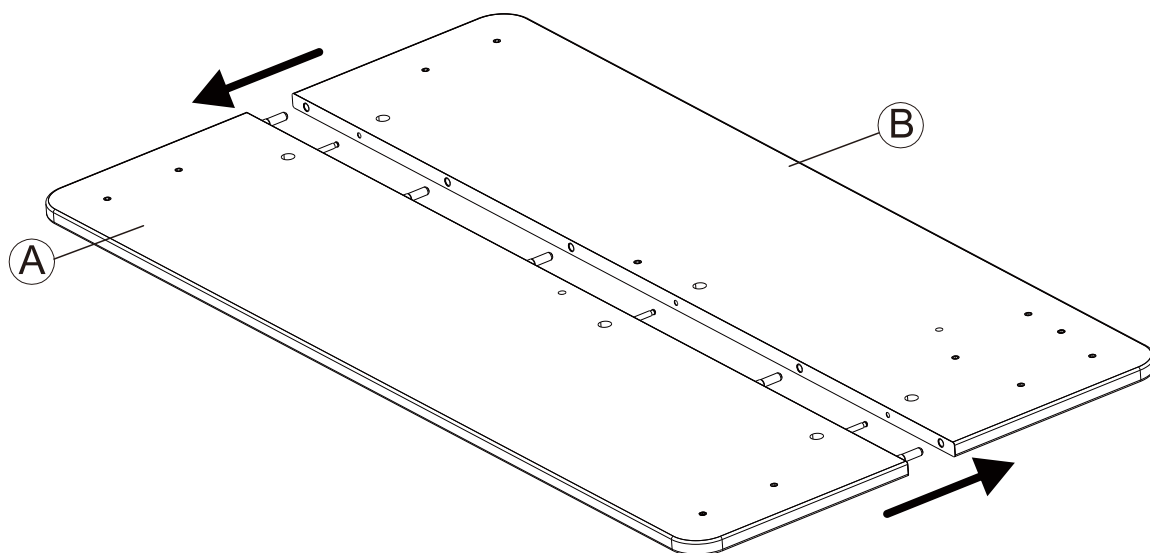

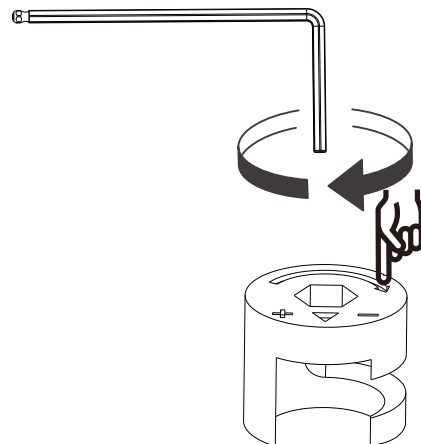
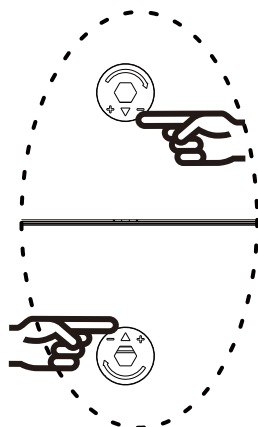
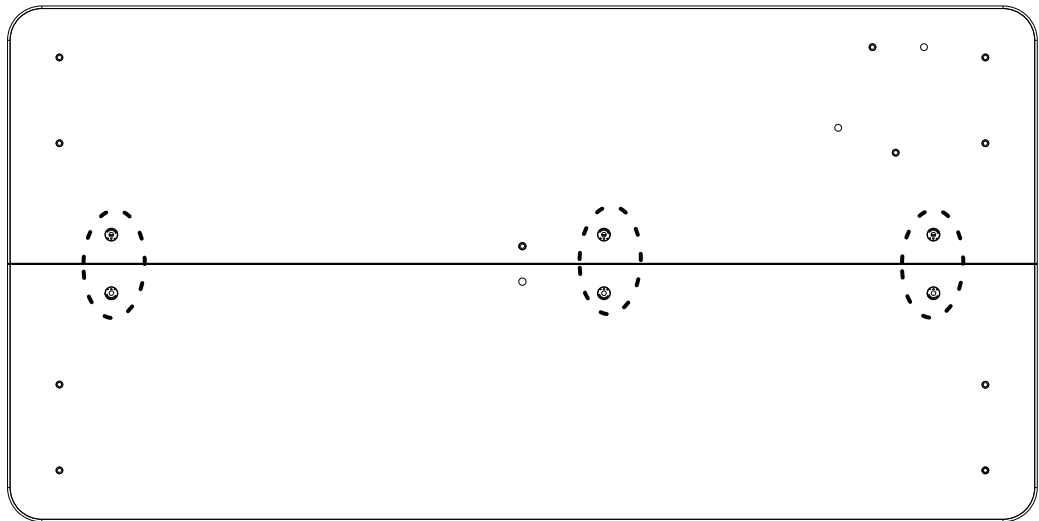
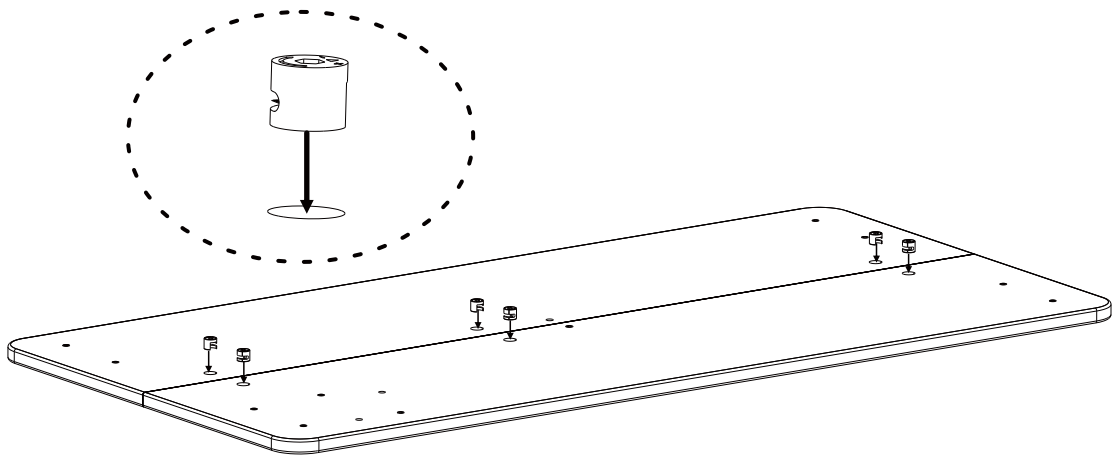
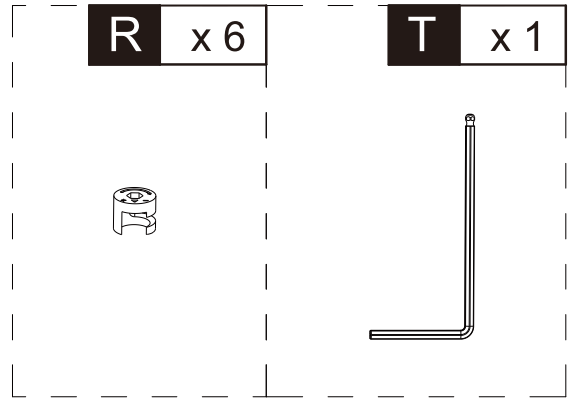

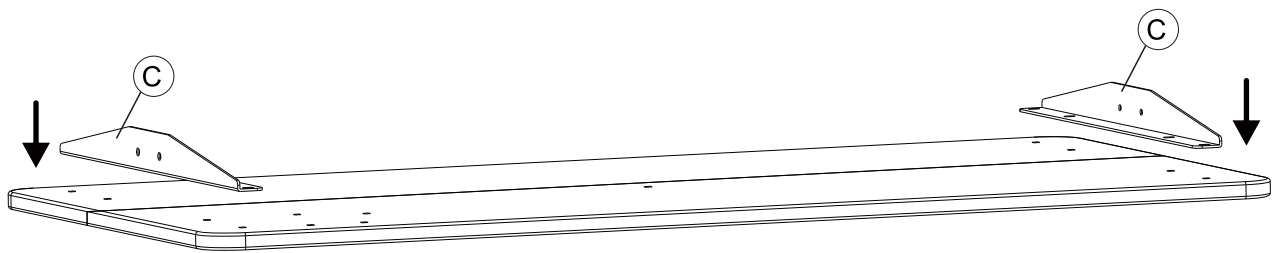
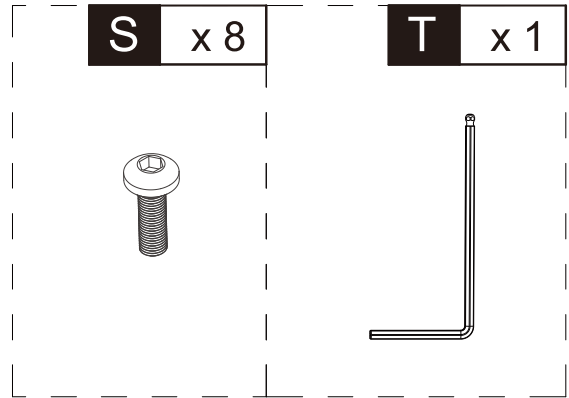

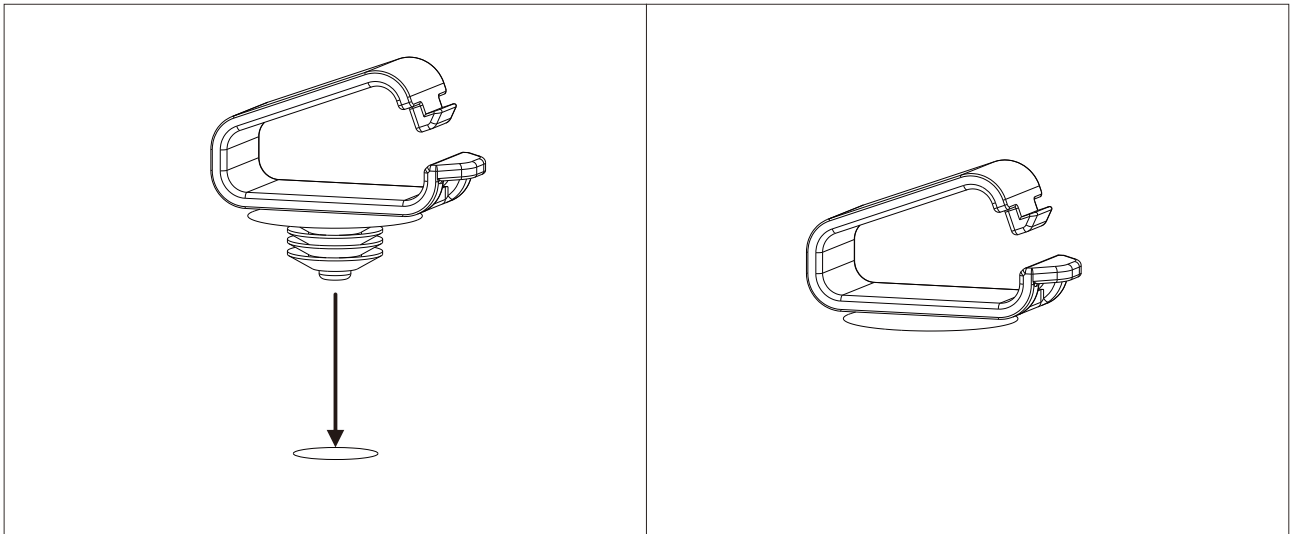
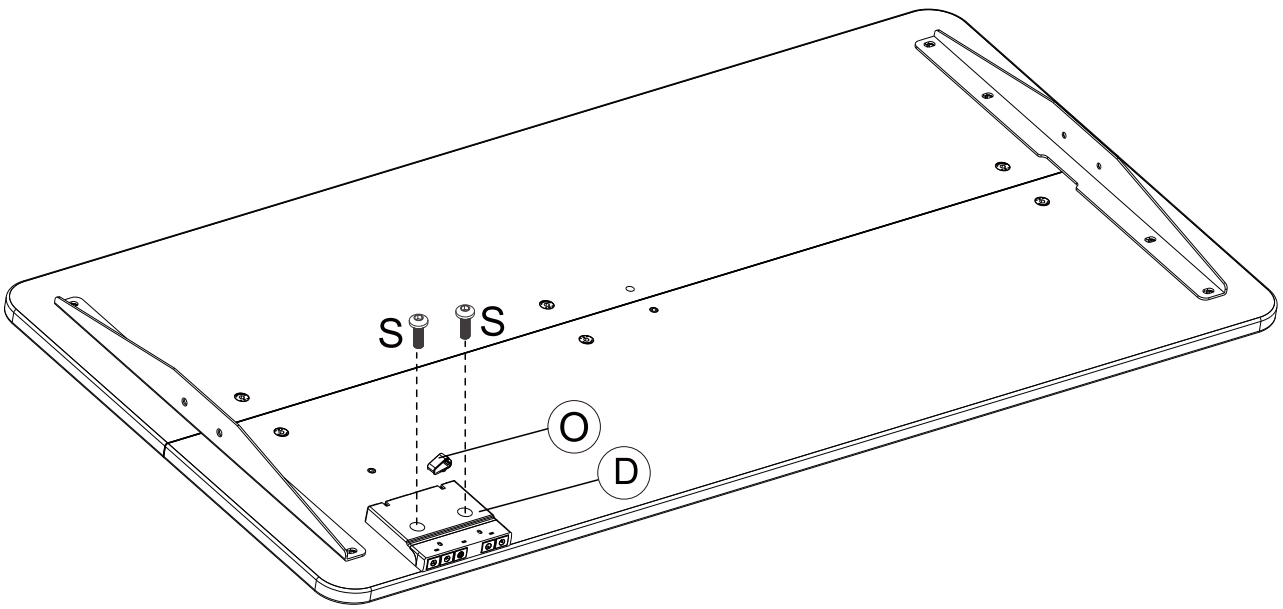
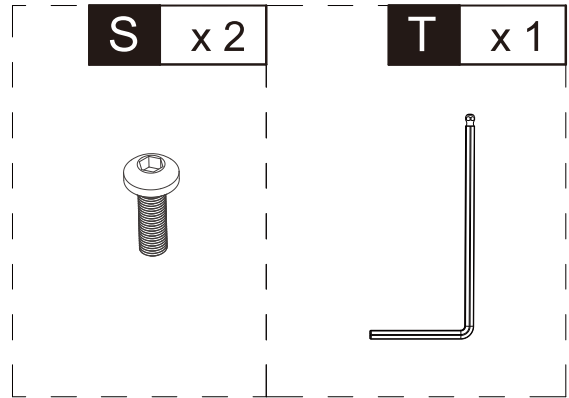

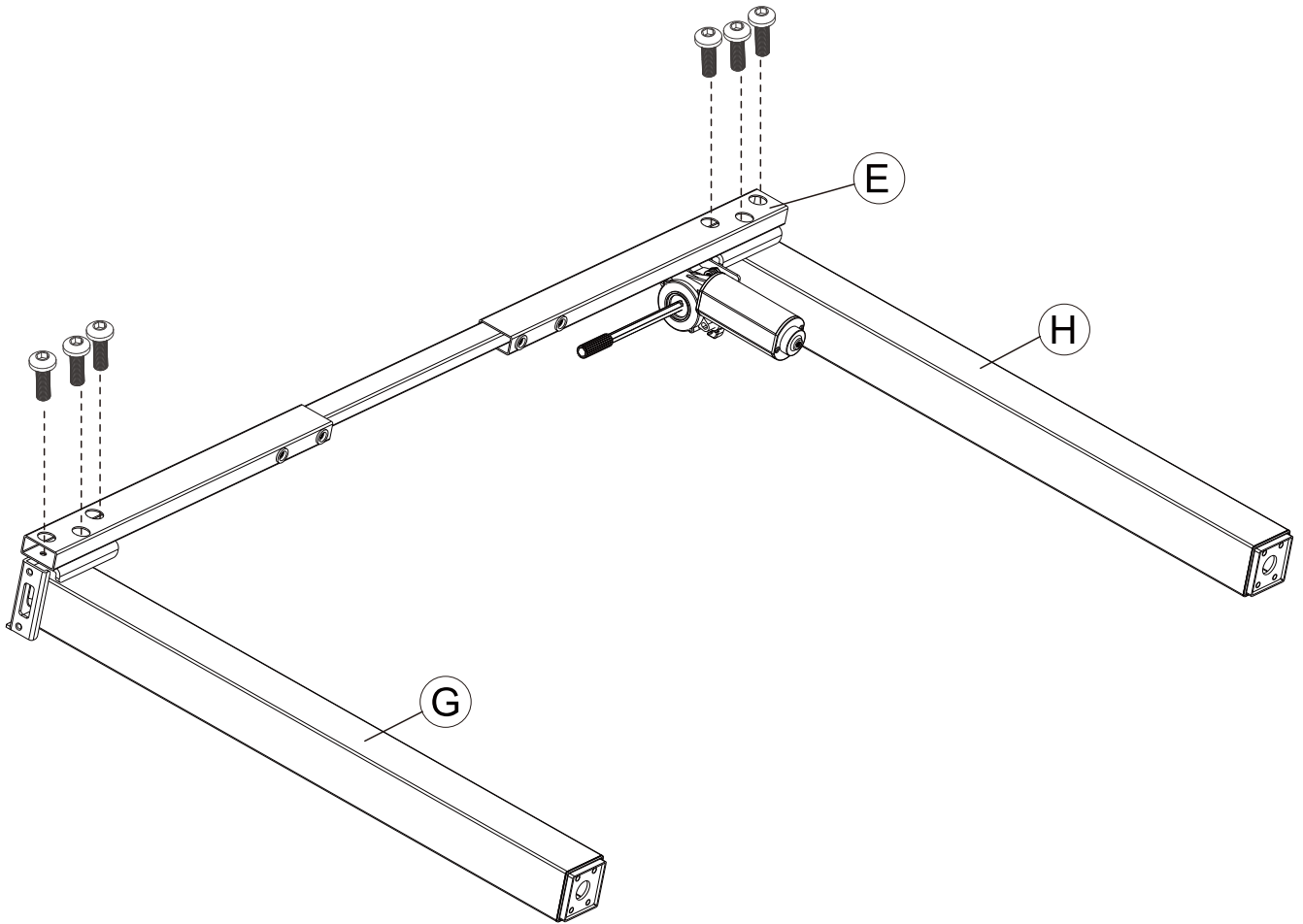
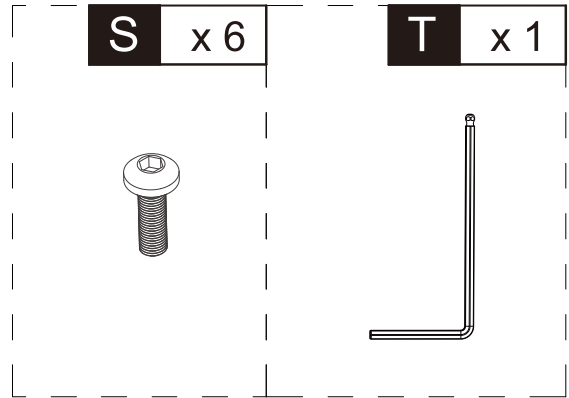

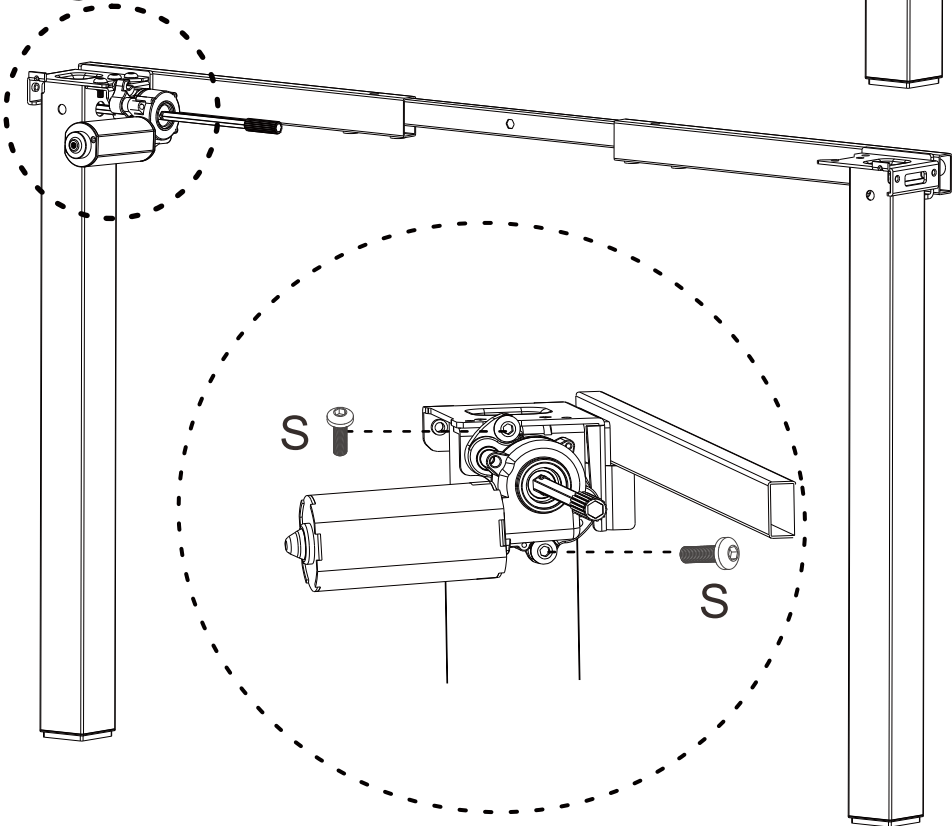
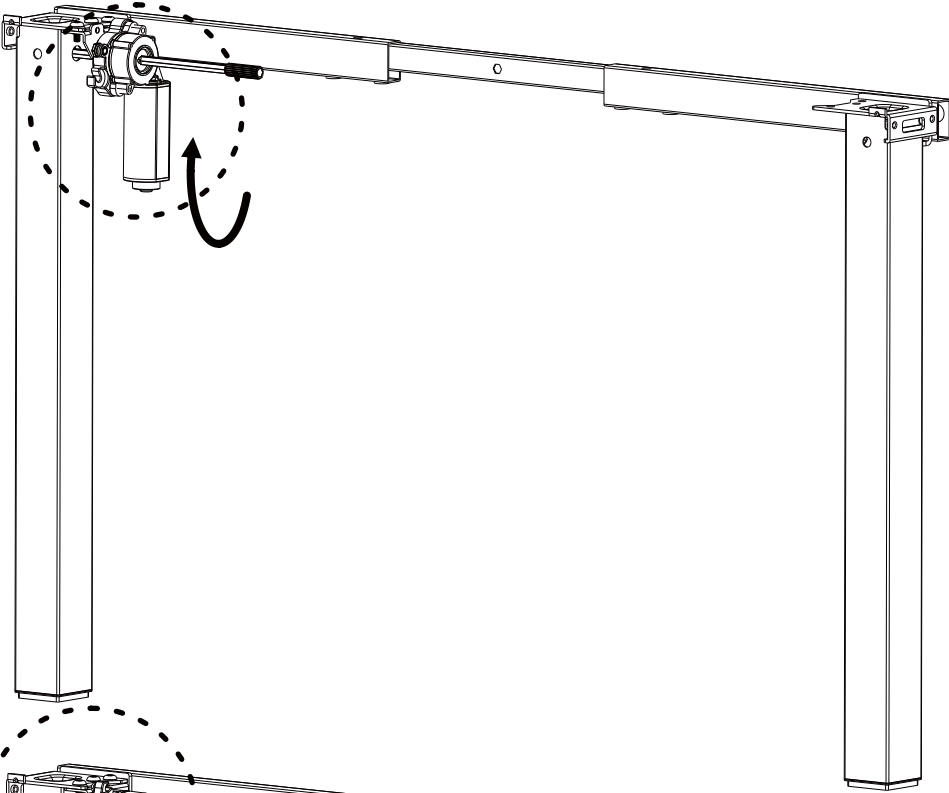
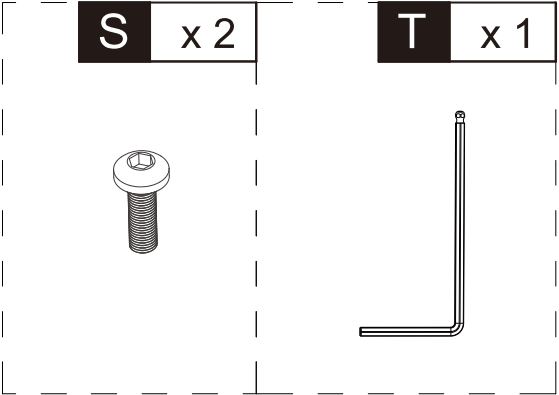

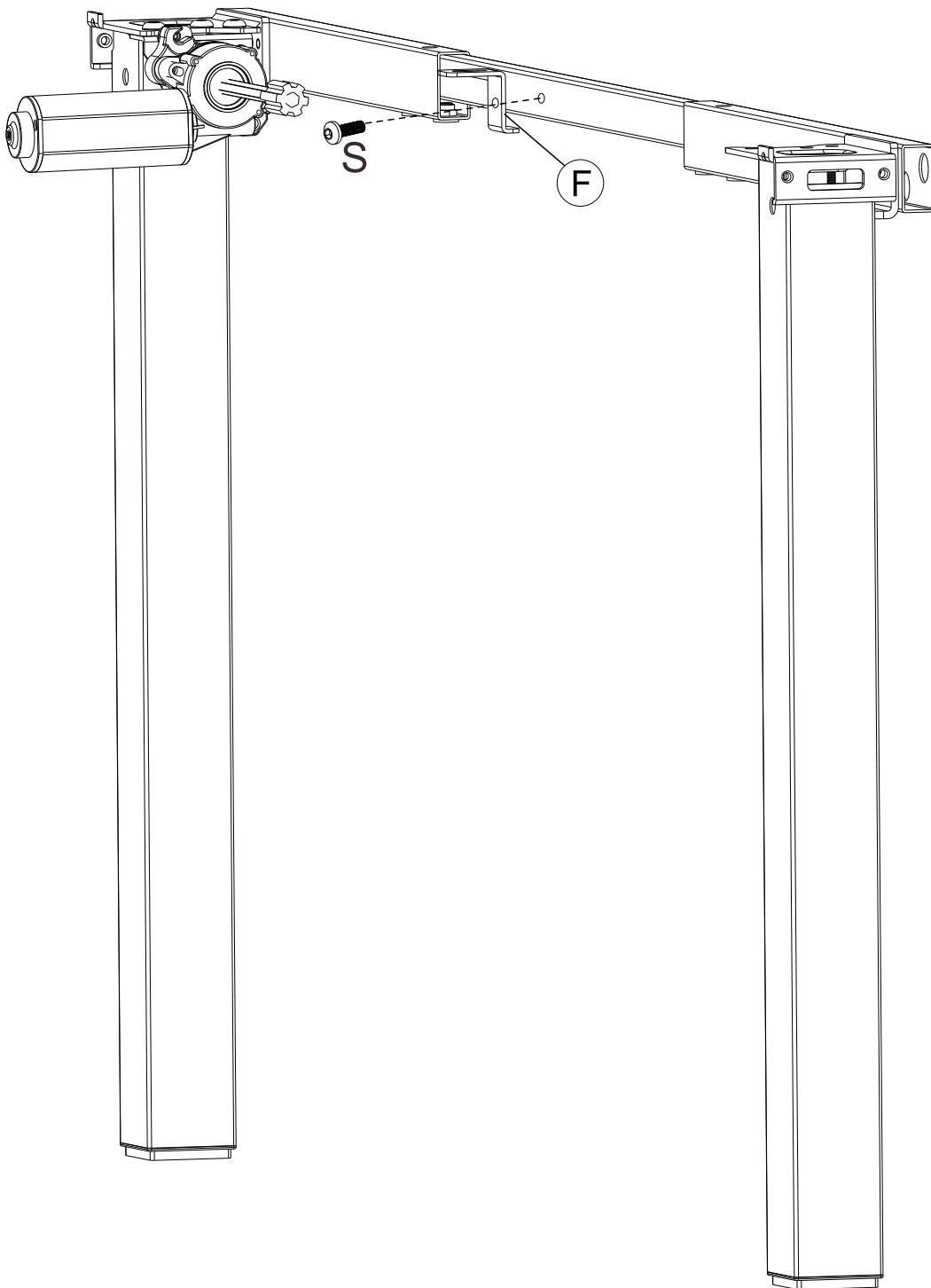
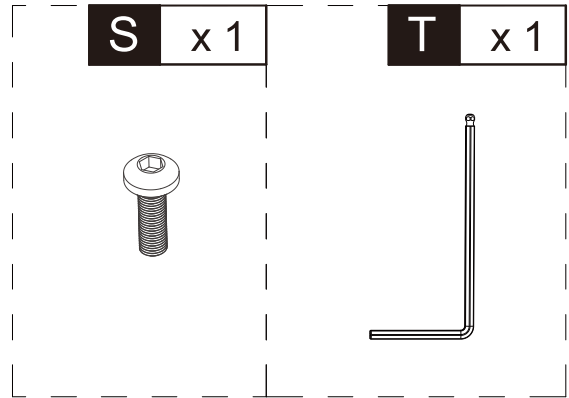

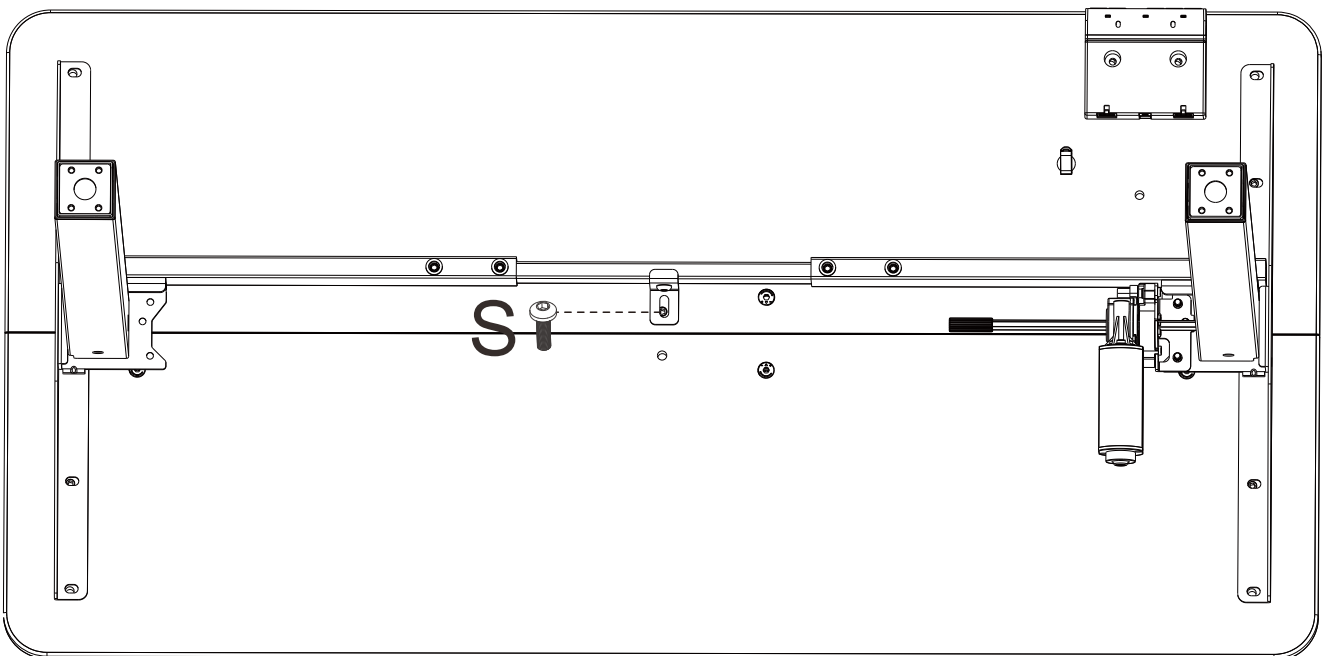
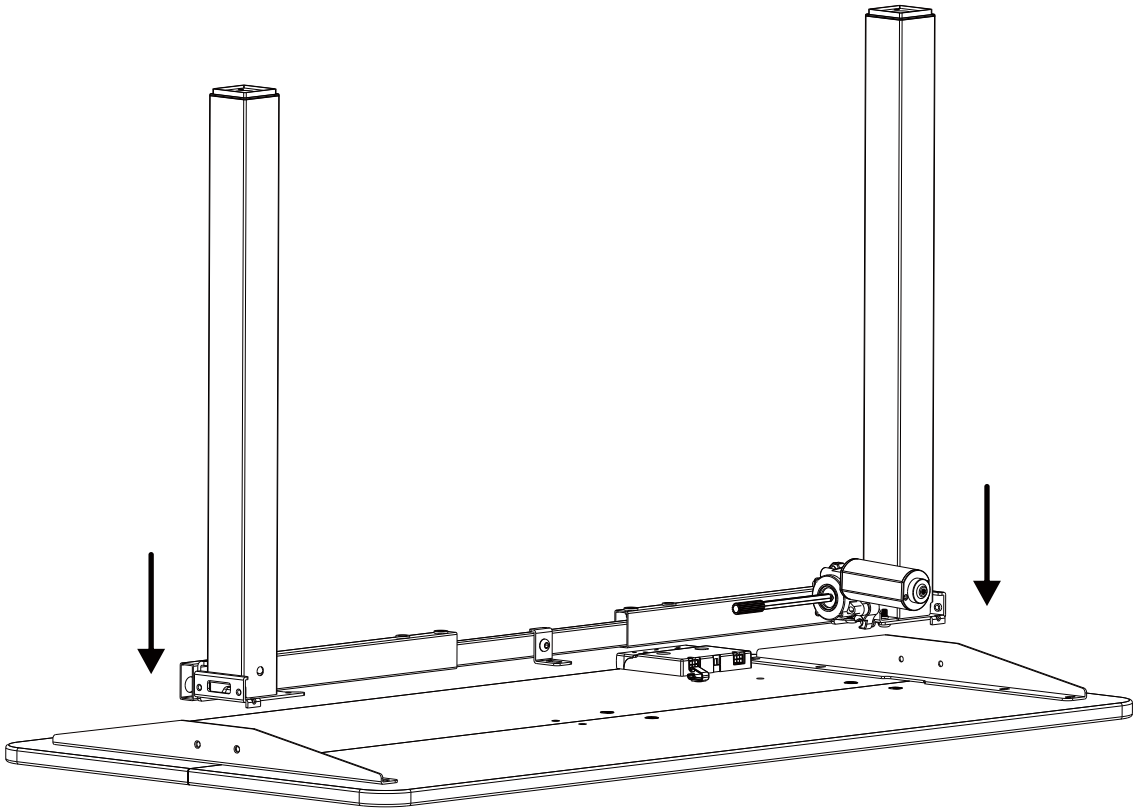
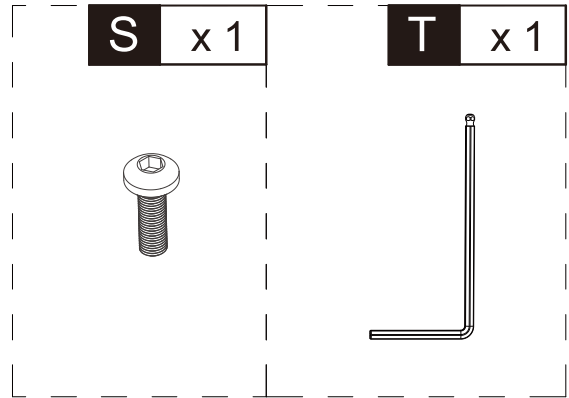

S x 4

T x 1

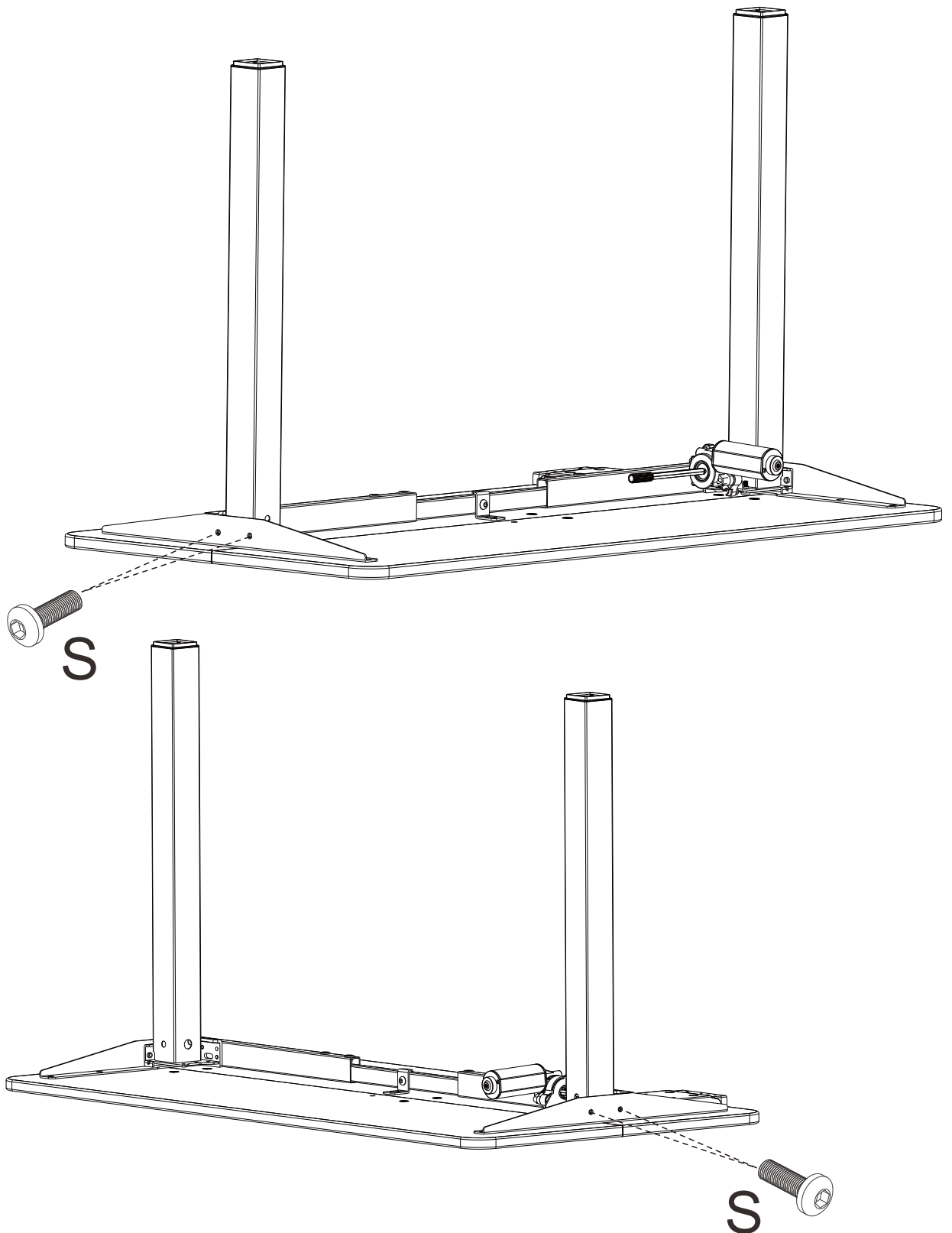
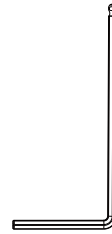
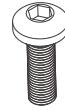

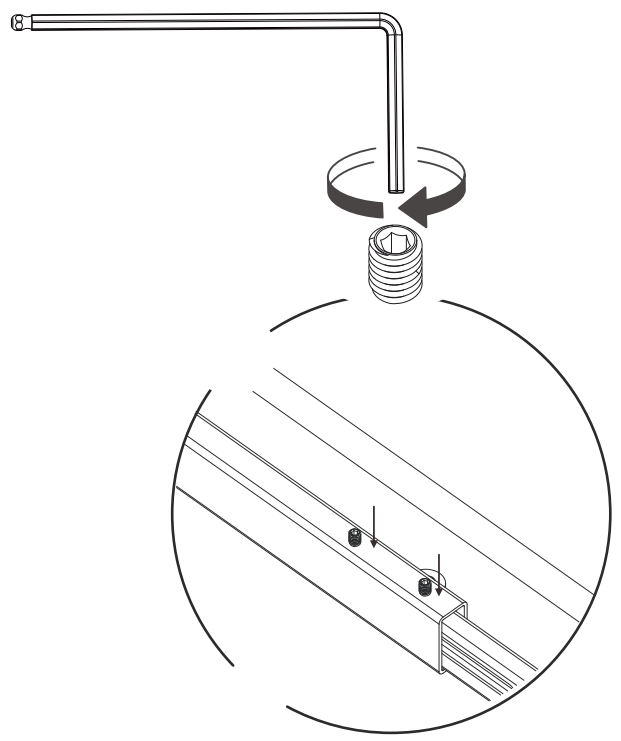
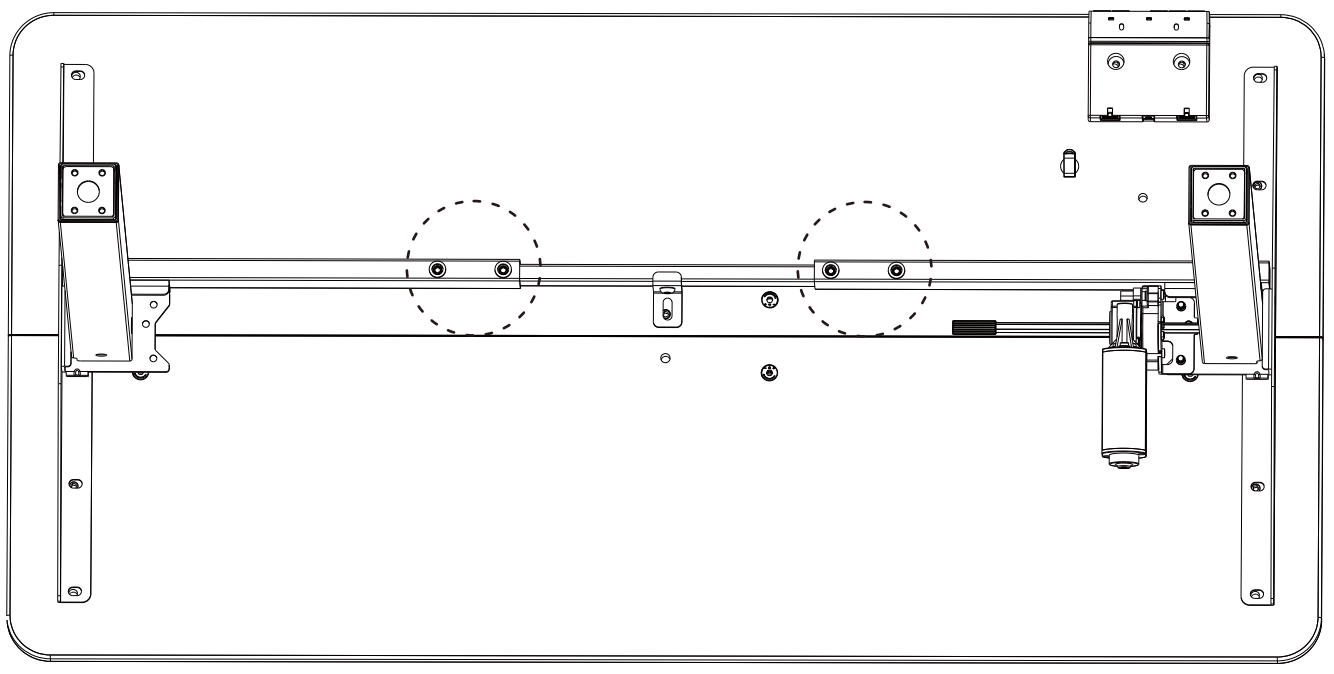
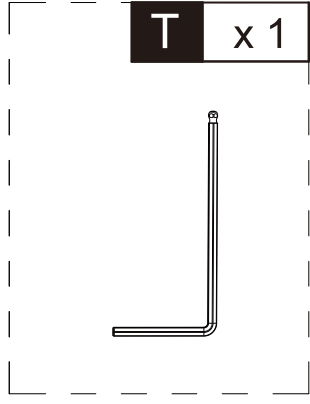

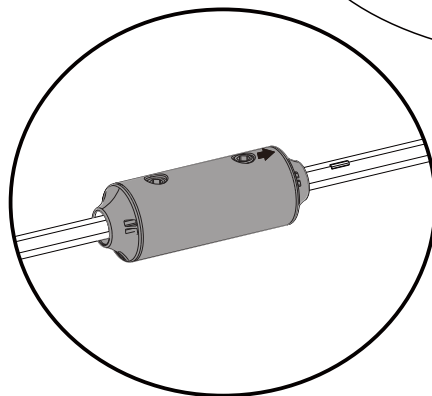
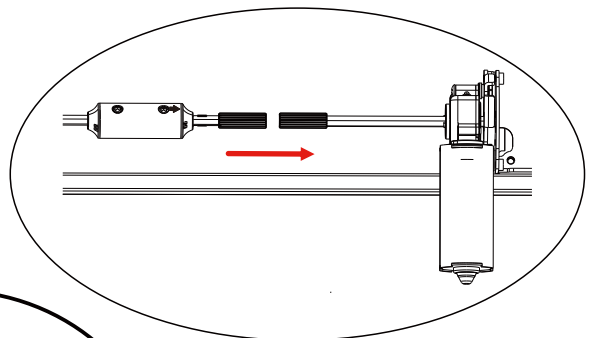
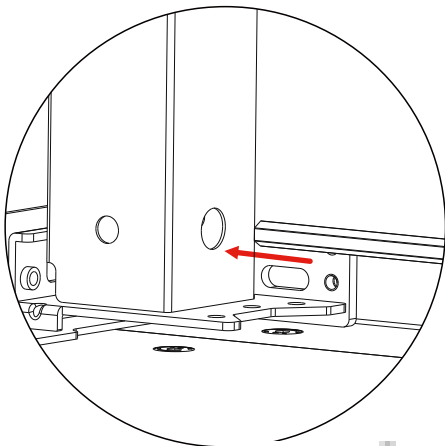
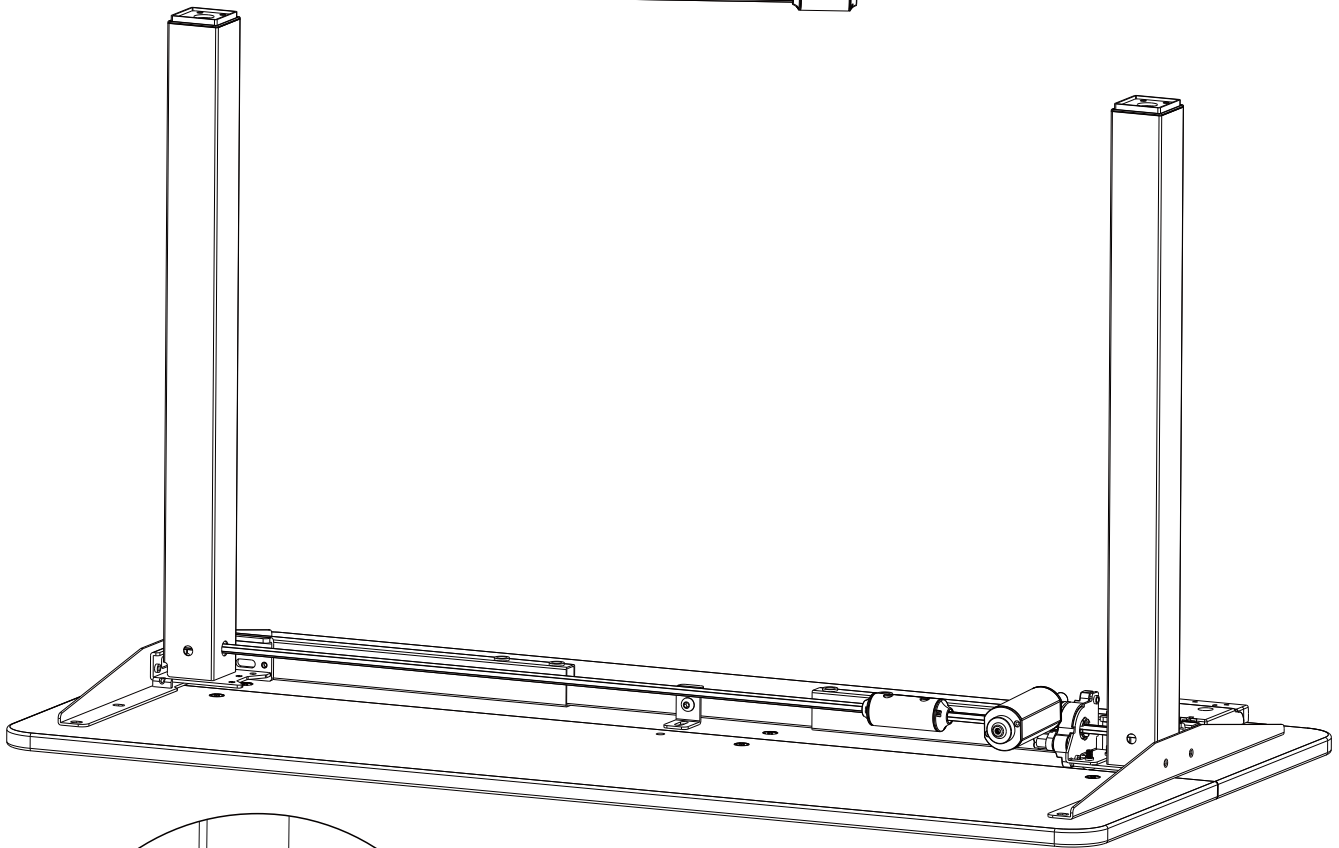
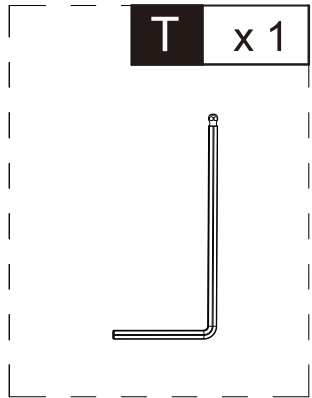
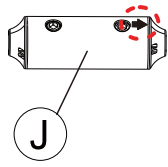
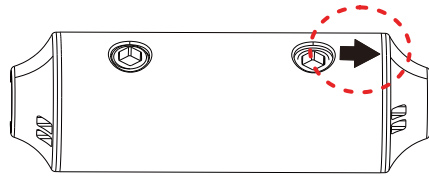

T x 1

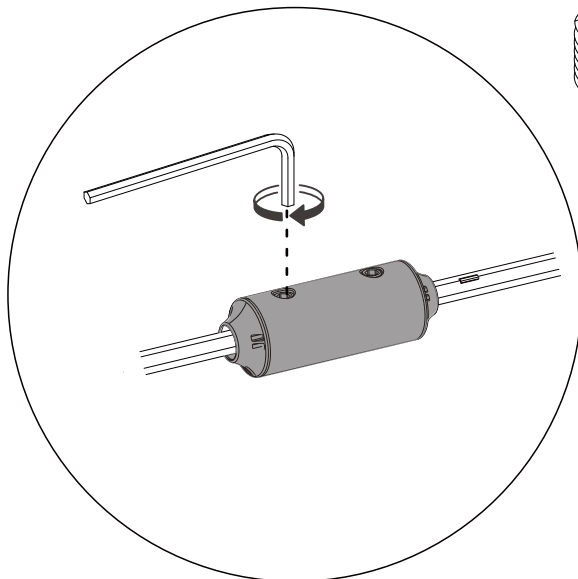
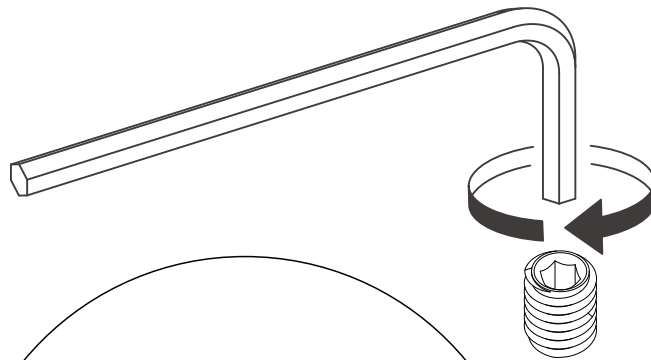
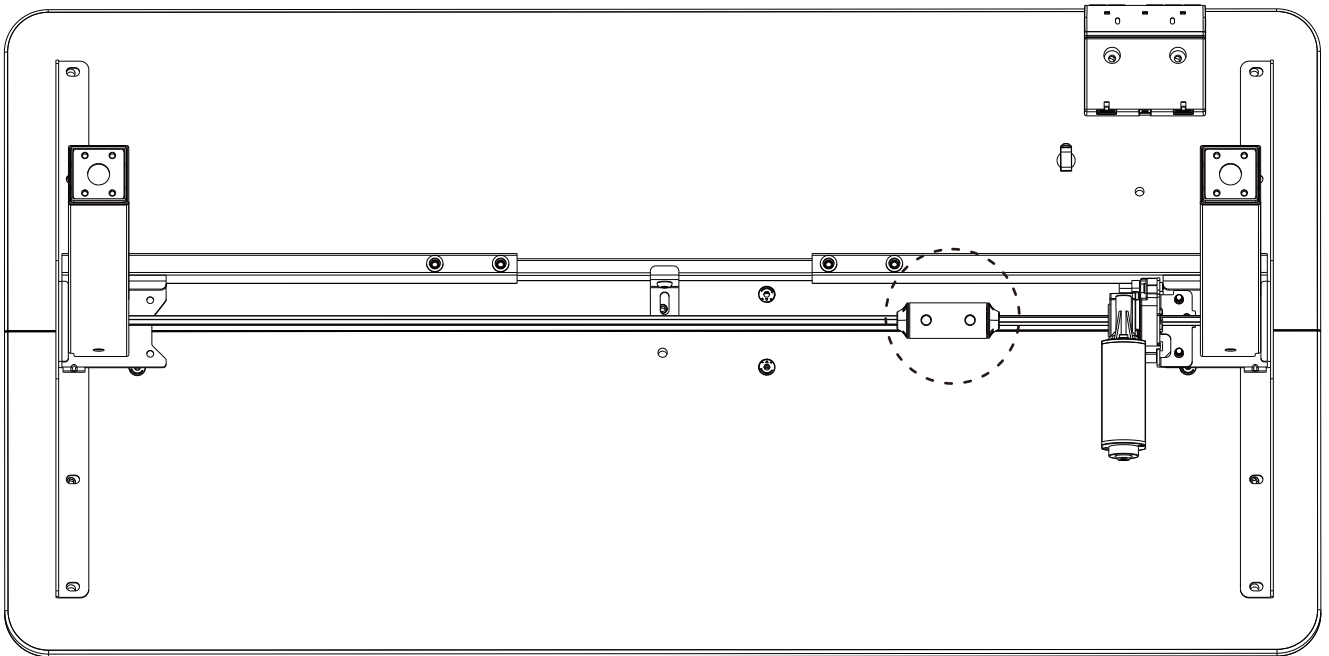
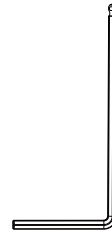

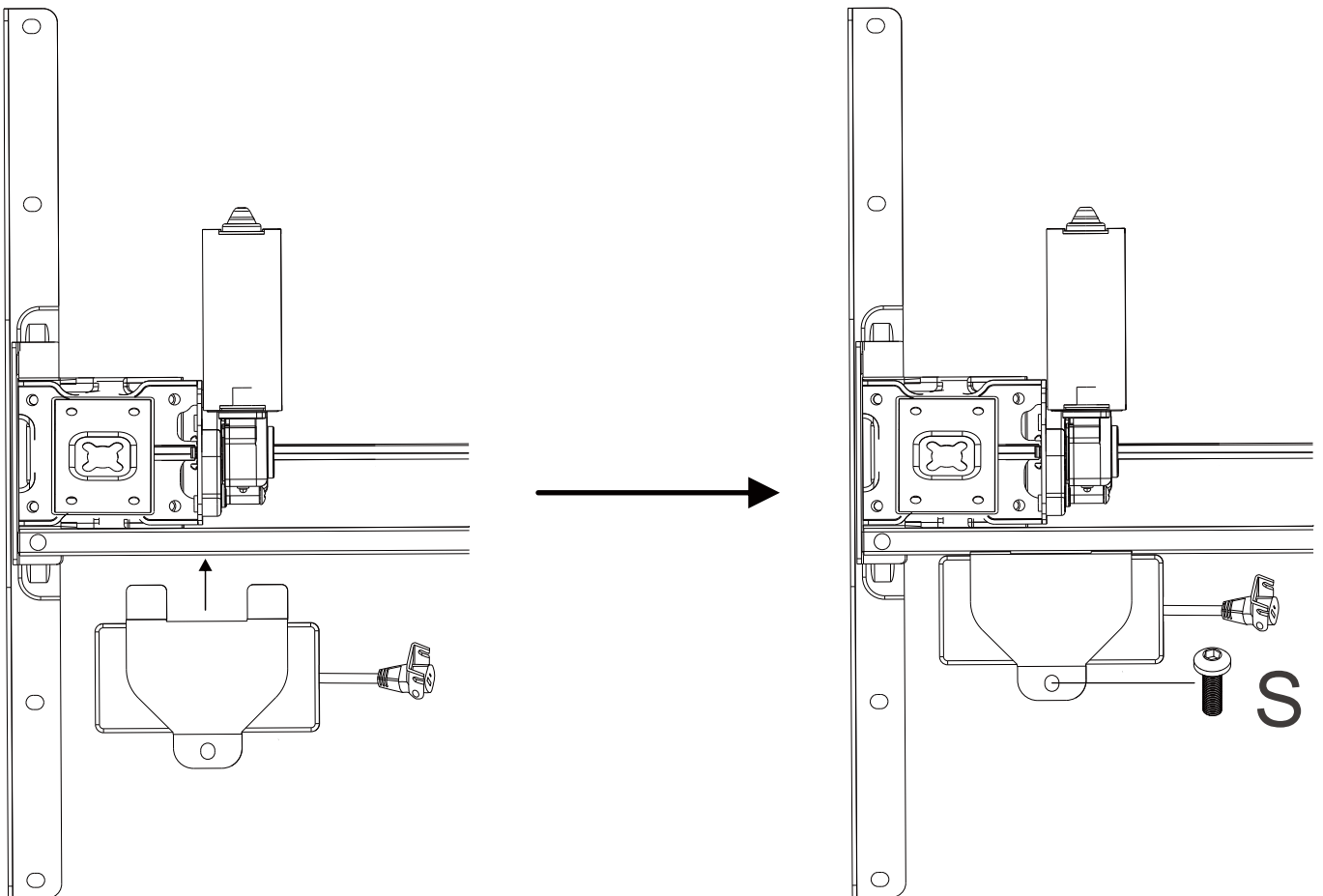
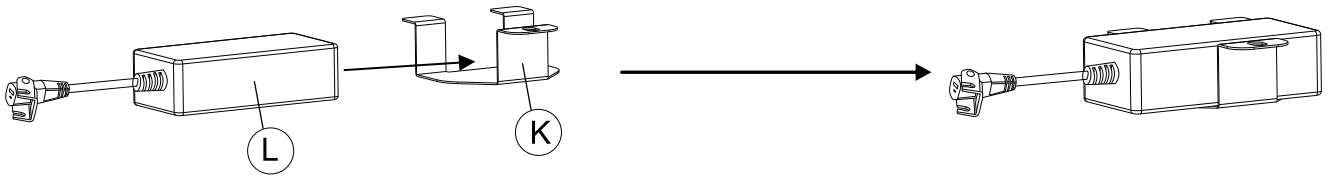
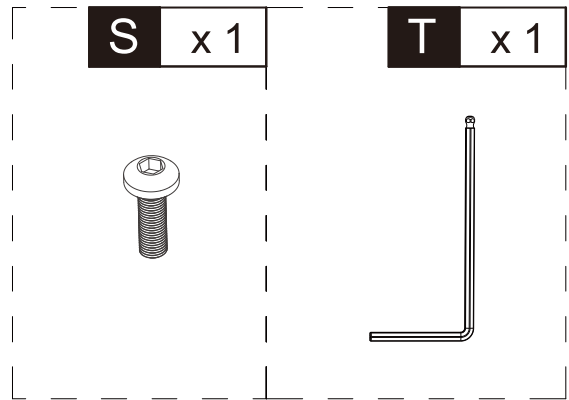

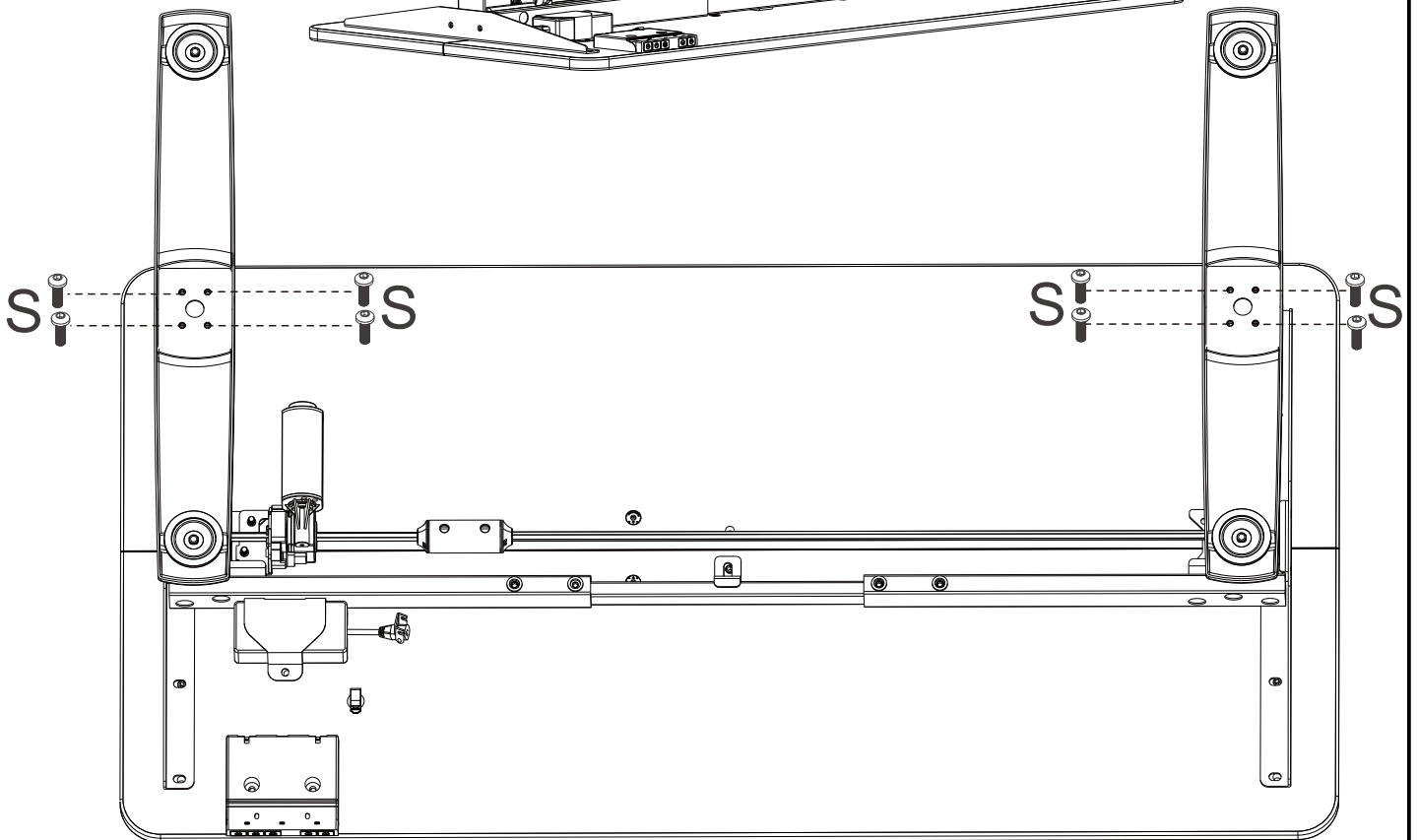
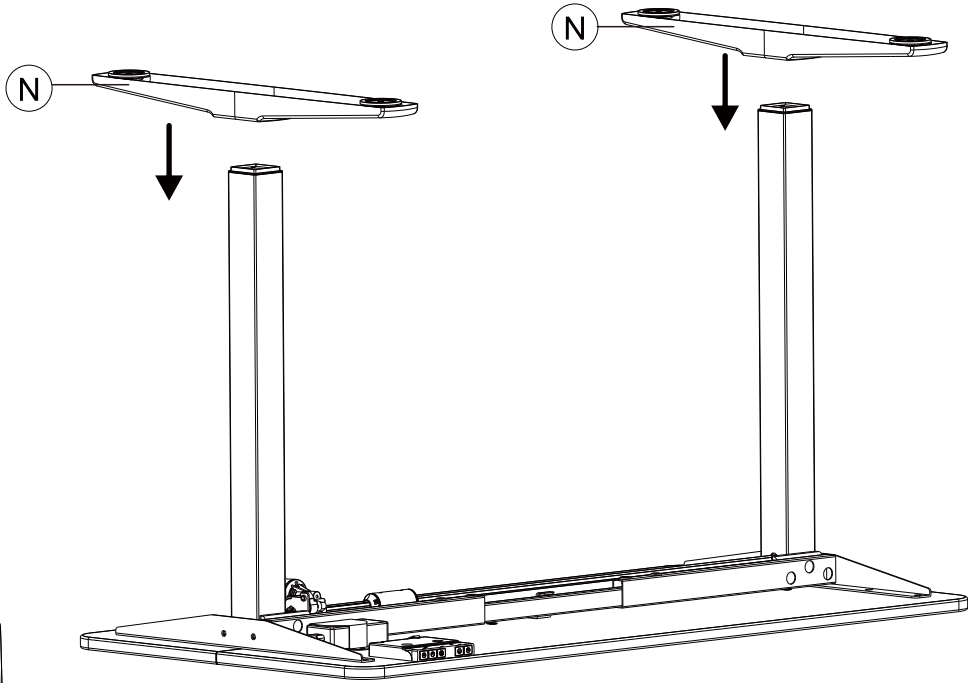
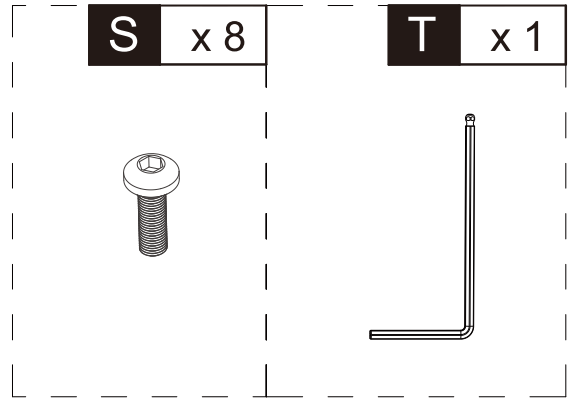

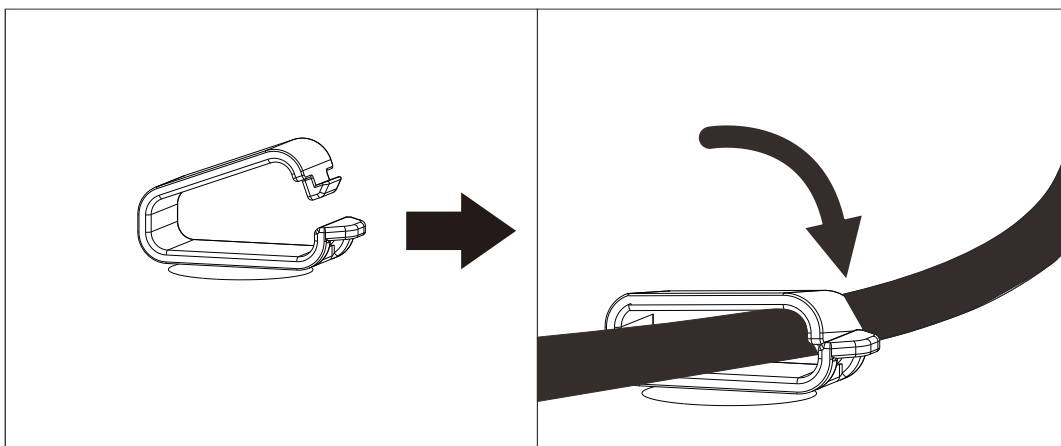
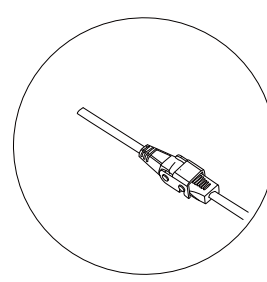
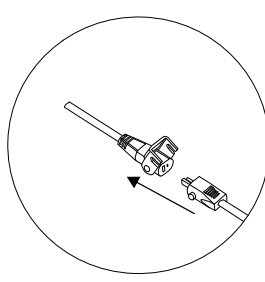
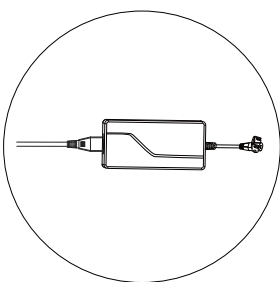
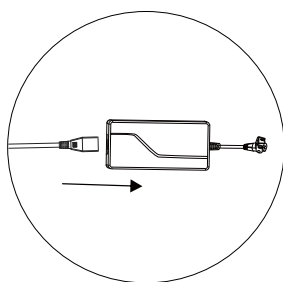
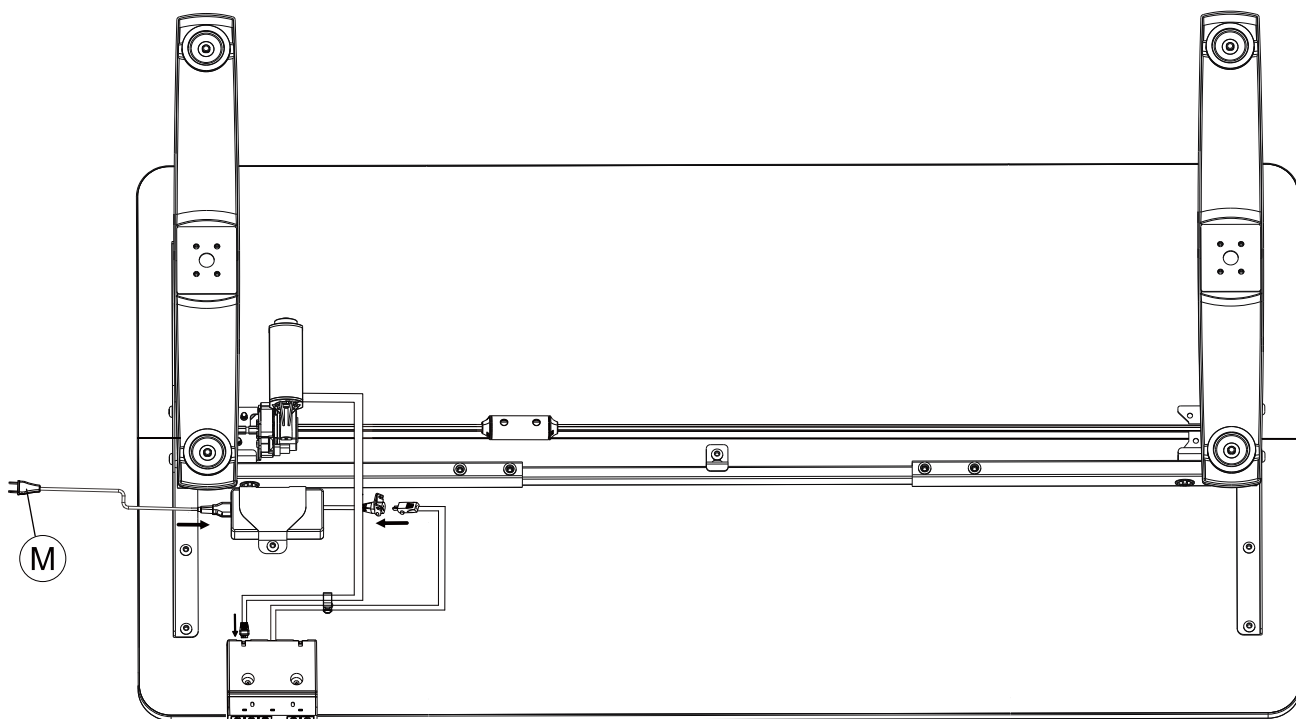

Guia de Uso:

IMPORTANTE: Você deve resetar a mesa antes do uso.

Certifique-se de que não há obstáculos no caminho da mesa.

Certifique-se de que a área de trabalho não está tocando em nenhuma parede.

Certifique-se de que todos os cabos têm o comprimento adequado para acomodar a mudança de altura.

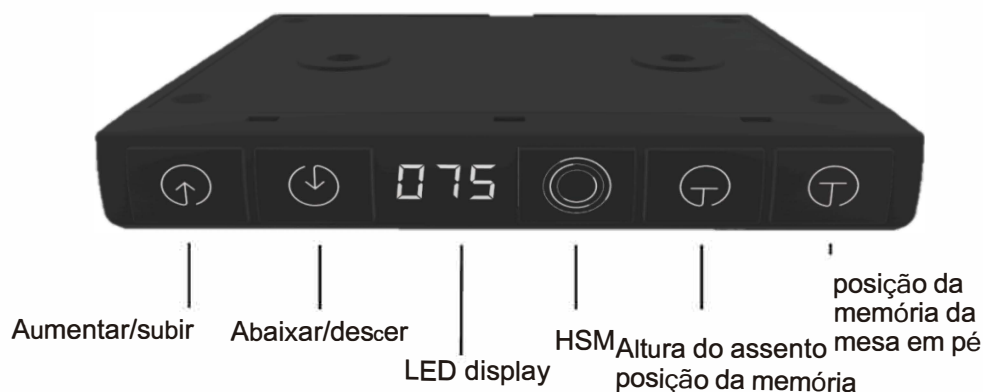

Nota:

Ao levantar ou abaixar a mesa, certifique-se de que os objetos estejam seguros sobre a mesa e que nada impeça que a mesa suba ou abaixe até o ajuste desejado.

Sugestão:

Por favor, defina a altura preferida da mesa enquanto está sentado pressionando a "tecla de memória da posição sentada" e a altura preferida da mesa enquanto está de pé pressionando "a tecla de memória da altura em pé".

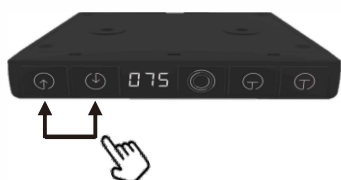

Ajuste da Altura da mesa

Pressione subir ou descer para levantar ou abaixar a mesa até a altura preferida.



Predefinições

Na altura da mesa inferior preferida para trabalhar sentado, pressione o esquerdo por 03 segundos ou mais para definir a memória

Na altura da mesa inferior preferida para trabalhar sentado, pressione o direito 03 segundos ou mais para definir a memória

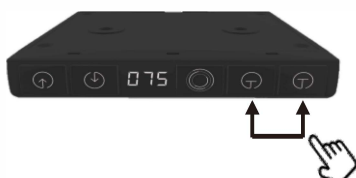

Uso das chaves

Brevemente pressione a chave esquerda e solte, a mesa se moverá para a altura de trabalho sentada preferida.

Brevemente pressione a chave direita e solte, a mesa se moverá para a altura de trabalho sentada preferida.

O ajuste da mesa é interrompido pressionando qualquer tecla no painel de controle

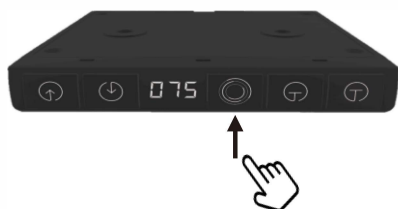

Modo HSM

Quando a luz estiver piscando, a mesa subirá lentamente 12 cm em 3 minutos, parará por 2 minutos e, em seguida, descerá lentamente 12 cm em 3 minutos. Após 2 minutos, os movimentos serão repetidos.

Power ON/OFF

1. Pressione  no painel tecla para LIGAR o sistema operacional; a luz de fundo estará acesa;
 2. O sistema desliga automaticamente após 4 horas.
- * Ao operar outras teclas, a luz de fundo é desligada.



Reset control pad

Na posição mais baixa ou quando solicitado pela mensagem "proteção e alarme", pressione a seta para baixo () por 3+ segundos, a mesa move-se totalmente para baixo e sobe até uma altura predefinida, momento em que a reinicialização é concluída.

Aviso; Os objetos sob a mesa devem ser removidos antes da operação de reinicialização para evitar danos à mesa ou outros itens.

Proteção e Alarme:



Anti-interferência: a mensagem/alarme "E02" aparece quando a área de trabalho vibra, sofre interferência ou inclina durante um ajuste. Pare o ajuste imediatamente e inverta o movimento; depois de um certo ajuste o alarme desaparecerá.



Proteção contra superaquecimento: a mensagem/alarme "Quente" aparece quando o tempo de ajuste contínuo excede 2 minutos, a proteção contra superaquecimento será acionada. Parar ajuste imediatamente: aguarde 18 minutos após os quais o alarme desaparecerá.



Proteção da função manual do motor; aparece a mensagem/alarme "E10". O poder deve ser desconectado, verifique novamente e certifique-se de que o motor conectado ao controlador esteja seguro, conecte à fonte de alimentação.



Proteção contra sobrecarga; a mensagem/alarme "E20" aparece quando a mesa é elevada com sobrecarga. Remova o peso e objetos pesados da mesa antes dos ajustes. Se ocorrer sobrecarga ao abaixar a mesa, pressione seta para baixo por mais de 3 segundos para reiniciar.



Proteção fora de sincronia; aparece a mensagem/alarme "E60" (somente sistemas multimotores!)

A alimentação deve ser desconectada, verifique novamente e certifique-se de que o motor conectado ao controlador esteja seguro, conecte à fonte de alimentação para reinicialização.