

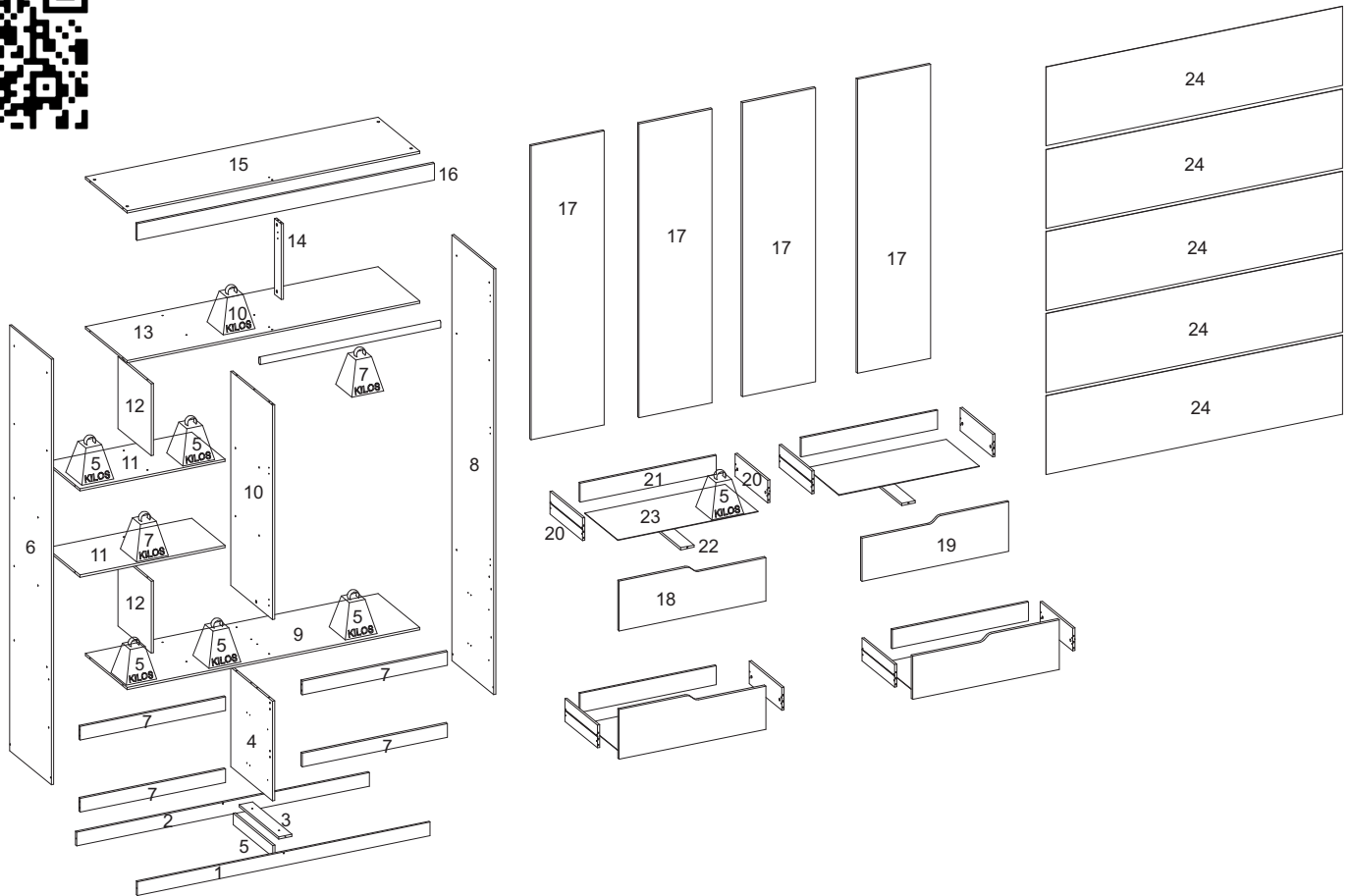

178 - GUARDA ROUPA CIRCUS



LISTA DE PEÇAS / PIECES LIST / LISTA DE PIEZAS

SEQ.	REF.	DESCRIÇÃO	DESCRIPTION	DESCRIPCIÓN	MAT.PRIMA	COMP.	LARG.	ESP.	QTD.
1	330978	Rodapé frontal	Front skirting.	Zócalo delantero.	MDP	1578	72	12	1
2	330979	Rodapé traseiro	Back plinth.	Zócalo trasero.	MDP	1578	72	12	1
3	330980	Trava divisória	Divisory lock.	Cerradura divisoria.	MDP	425	72	12	1
4	330981	Divisória inferior	Lower partition.	Tabique inferior.	MDP	526	450	12	1
5	330982	Trava rodapé	Footer lock.	Bloqueo de pie de página.	MDP	425	60	12	1
6	330983	Lateral esquerda	Left side.	Lado izquierdo.	MDP	2250	450	12	1
7	330984	Vista gaveta	Drawer view	Vista del cajón	MDP	783	72	15	4
8	330985	Lateral direita	Right lateral.	Lateral derecho.	MDP	2250	450	12	1
9	330986	Base	Base	Base	MDP	1578	450	12	1
10	330987	Divisória superior	Upper partition.	Tabique superior.	MDP	1132	450	12	1
11	330988	Prateleira	Shelf.	Estante.	MDP	783	359	12	2
12	330989	Divisória nicho	Niche divider.	Divisor de nicho.	MDP	380	359	12	2
13	330990	Base maleiro	Base rack.	Estante base.	MDP	1578	450	12	1
14	330991	Batente superior	Top stop.	Parada superior.	MDP	400	72	12	1
15	330992	Chapéu	Top hat.	Sombrero de copa.	MDP	1578	450	12	1
16	330993	Vista superior	Top view.	Vista superior.	MDP	1602	88	15	1
17	330994	Porta	Door.	Puerta.	MDP	1554	394	15	4
18	330995	Frente de gaveta esquerda	Front of left drawer.	Frente del cajón izquierdo.	MDP	791	263	15	2
19	330996	Frente de gaveta direita	Drawer front right	Cajón frontal derecho	MDP	791	263	15	2
20	330997	Lateral de gaveta	Drawer side	Lado del cajón	MDP	350	120	12	8
21	330998	Contra fundo	Back.	Atrás.	MDP	734	100	12	4
22	330999	Apoio de gaveta	Drawer support.	Soporte para cajones.	MDP	350	72	12	4
23	331000	Fundo da gaveta	Drawer bottom.	Fondo del cajón.	HDF	756	355	3	4
24	331001	Fundo	Bottom.	Fondo.	HDF	1598	417	3	5

INSTRUÇÃO MONTAGEM PRODUTO
 Instructions to Assembly / Instrucciones de montaje

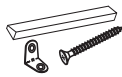

Separe as peças e acessórios de maneira organizada
 Separate parts and accessories in way organized
 Separe las piezas y accesorios de manera organizada

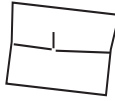

Forrar o chão com o papelão das embalagens.
 Cover the floor with the cardboard
 Cubra el suelo con la embalaje de cartón



É necessário 02 pessoa para montar o produto
 02 people are required to assemble the product
 Se requieren 02 persona para ensamblar el producto

O produto deve ser a montado por um profissional qualificado
 The product must be assembly by a professional
 El producto debe ser ensamblado por un profesional calificado

Ferramentas necessárias
 (não fornecidas)

Not include tools / No herramientas



CUIDADO PARA CONSERVAÇÃO E LIMPEZA DO MÓVEL
 Care to conservation and clean / Cuidados de limpieza

Peso máximo de carga informado refere-se a objetos distribuido de maneira uniforme sobre toda área de contato da peça



The maximum load weight informed refers to objects distributed evenly over the entire contact area of the part
 Conjunto de carga máxima de peso se refiere a objetos distribuidos uniformemente sobre toda el área de contacto de la pieza de trabajo.



Não molhar o móvel e não expor em lugar úmido
 Do not wet the mobile and do not expose in a wet place
 No moje el producto y no exponer en un lugar húmedo



Não expor o móvel próximo de fontes de calor.
 Do not expose the mobile near heat sources
 no exponga cercano de fuentes de calor



Não usar produtos abrasivos.
 Do not use abrasive products.
 No utilice productos abrasivos.



Limpe com flanela limpa e seca.
 Clean with dry cloth
 Limpieza con un paño limpio y seco

LISTA DE ACESSÓRIOS E FERRAGENS / ACCESSORIES AND HARDWARE / ACCESORIOS Y HARDWARE



A - 700137- Parafuso 4,5x45 (42x)
 screw / tornillo



B - 700124-Parafuso 3,5x25 (32x)
 screw / tornillo



C - 700121-Parafuso 3,5x12 (149x)
 screw / tornillo



D - 700157-Prego (116x)
 nail / clavo



E - 700490 - Kit com 6 Pes (1x)
 foot / pie



F - 700542-Cavilha 6x30 (22x)
 peg / cerrojo



G - 700146-Parafuso minifix (11x)
 Minifix screw /
 Tornillo minifix



H - 700148-Tambor Minifix (11x)
 Minifix Drum / Tambor minifix



I - 700113-Corrediça (4x)
 runners / corredera



J - 700539-Cantoneira (8x)
 corner / esquina



K - 700127-Parafuso 4,0x12 (48x)
 screw / tornillo



L - 700446 - Porca cilíndrica (4x)
 Cylindrical Nut / Tuerca cilíndrica



M - 700438 - Suporte cabide (2X)
 hook support / soporte gancho



N - - 700361 - Cabideiro Alumínio (1x)
 Coat Rack / Perchero

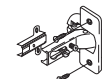

O- 700395 - Dobradiça (12x)
 700390 - Calço (12x)
 hinge / bisagra



P- 702105-Puxador 600 mm (4x)
 Handle / Manija



Q- -702119 - Perfil H (3x)
 Frame / Perfil



R- 700538 - Cantoneira (4x)
 corner / esquina



S- 700543 - Cavilha 6x60 (7x)
 peg / cerrojo



T- 700547 - Junção (5x)
 junction / juncion



U- 700419-Tapa furo (50x)
 cover / tapa



V- 700516 - Cola (1x)
 glue / pegamento

01° PASSO - Fixar os acessórios nas peças 4,6 e 8

01° STEP - Fix the fittings to parts 4,6 and 8

01° PASO - Fijar los accesorios a las piezas 4,6 y 8

C



I



S

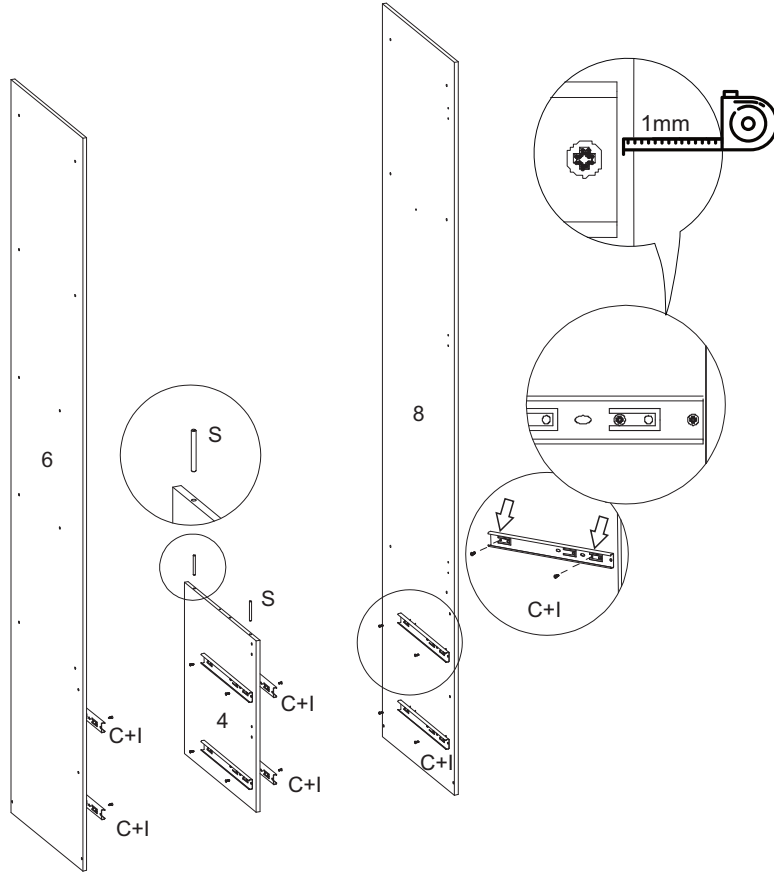

02° PASSO - Fixar peça 3 nas peça 4

02° STEP - Fix part 3 to part 4

02° PASO - Fijar parte 3 a parte 4

A

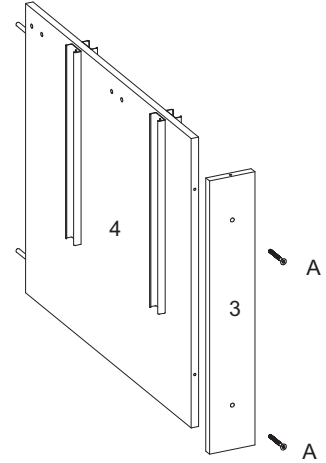
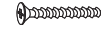

03° PASSO - Fixar os acessórios nas peças 1,2 e 3

03° STEP - Fix accessory to parts 1,2 and 3

03° PASO - Fijar los accesorios a las partes 1,2 y 3

C



J

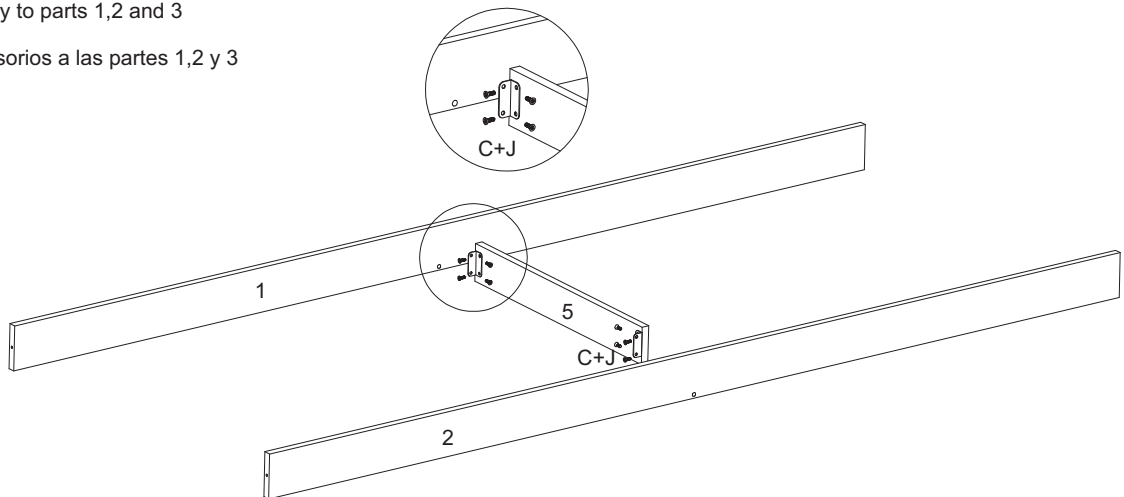

04° PASSO - Fixar os acessórios nas peças 1,2 e 3

04° STEP - Fix accessory to parts 1,2 and 3

04° PASO - Fijar los accesorios a las partes 1,2 y 3

E

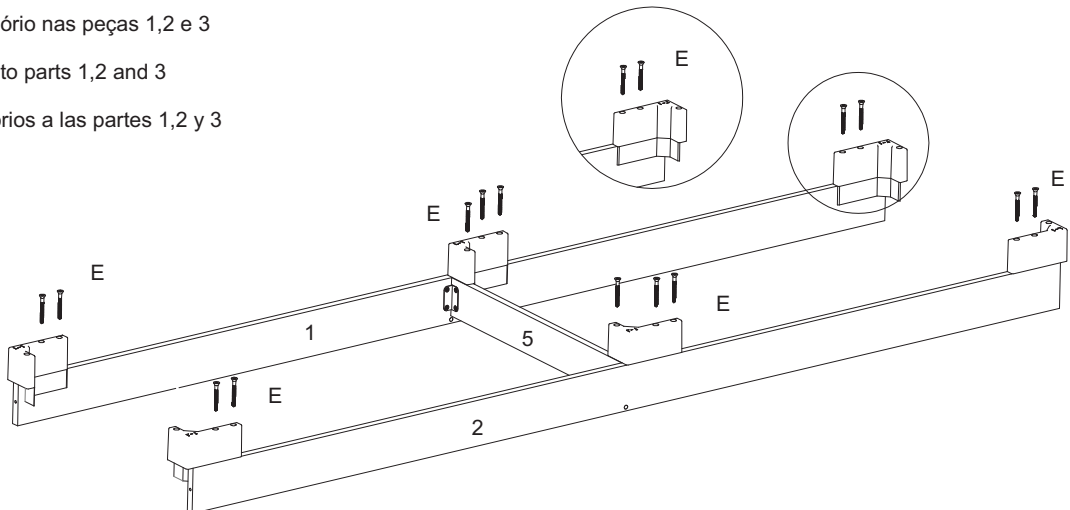

05° PASSO - Fixa a peça 3 nas peças 1 e 2

05° STEP - Fix part 3 to parts 1 and 2

05° PASO - Fijar la parte 3 a las partes 1 y 2

A

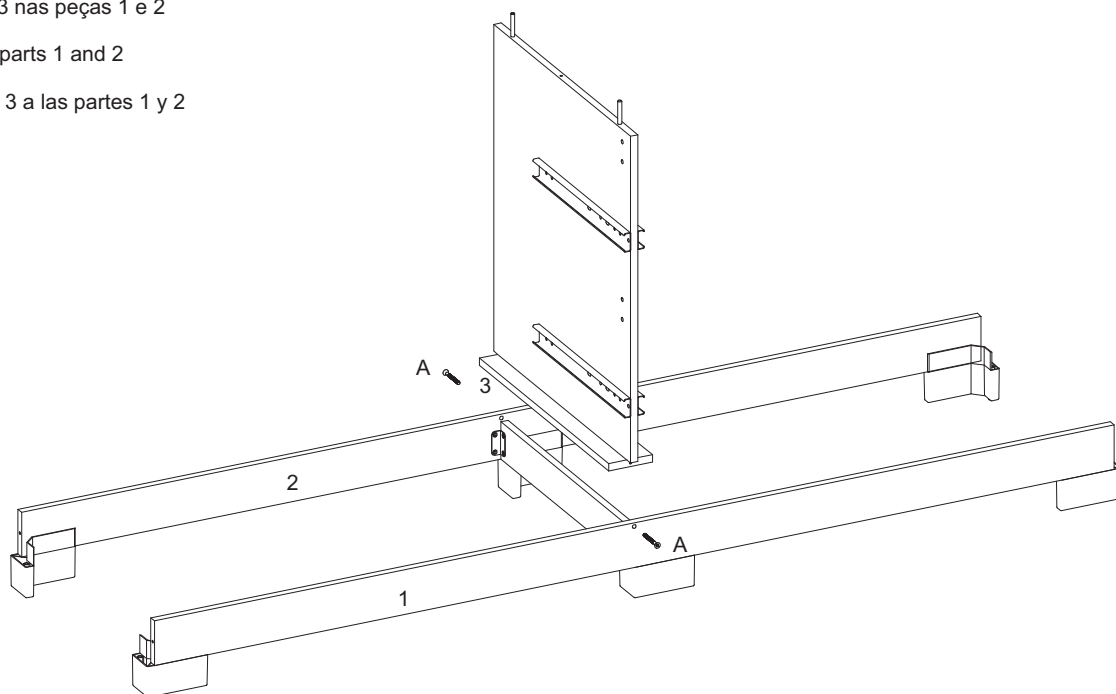

06° PASSO - Fixar peças 7 nas peças 4 e 6

06° STEP - Fix parts 7 to parts 4 and 6

06° PASO - Fijar las partes 7 a las partes 4 y 6

A



S

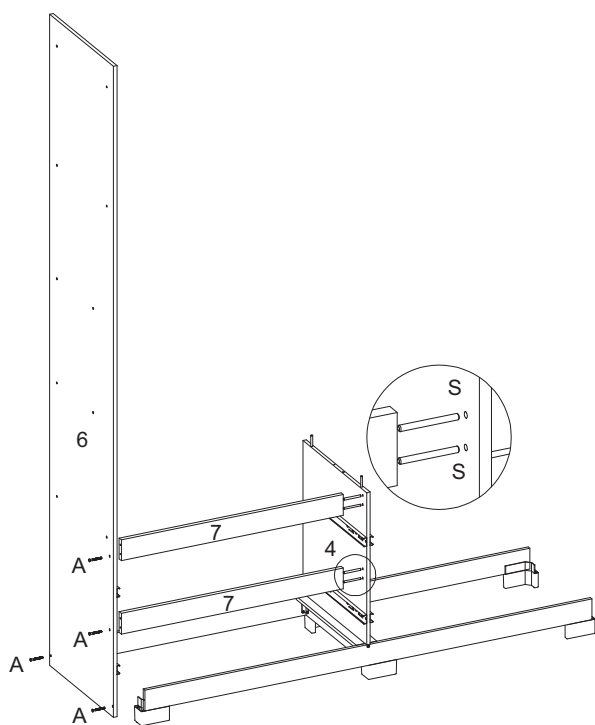

07° PASSO - Fixar as peças 7 nas peças 4 e 8

07° STEP - Fix parts 7 to parts 4 and 8

07° PASO - Fijar las partes 7 a las partes 4 y 8

A

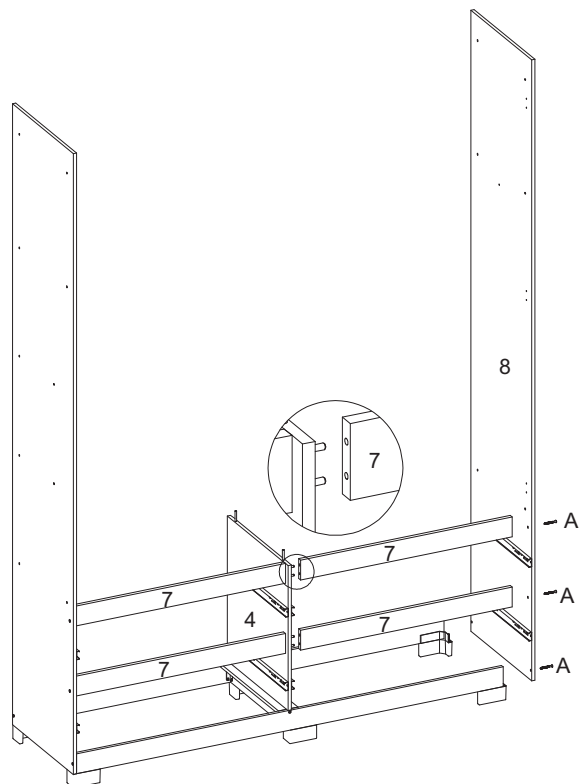

08° PASSO - Fixar peça 9 nas peças 4, 6 e 8

08° STEP - Fix part 9 to parts 4, 6 and 8

08° PASO - Fijar la parte 9 a las partes 4, 6 y 8

A

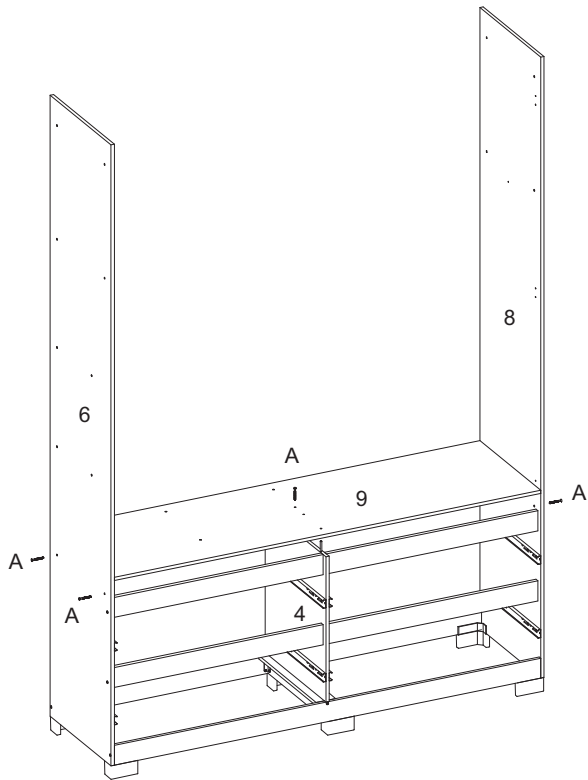

09° PASSO - Fixar peça 10 na peça 9. Fixar peças 11 na peças 6 e 10

09° STEP - Fix parts 11 and 10 to parts 8 and 12

09° PASO - Fijar la parte 10 con la parte 9. Fijar la parte 11 con las partes 6 y 10

A

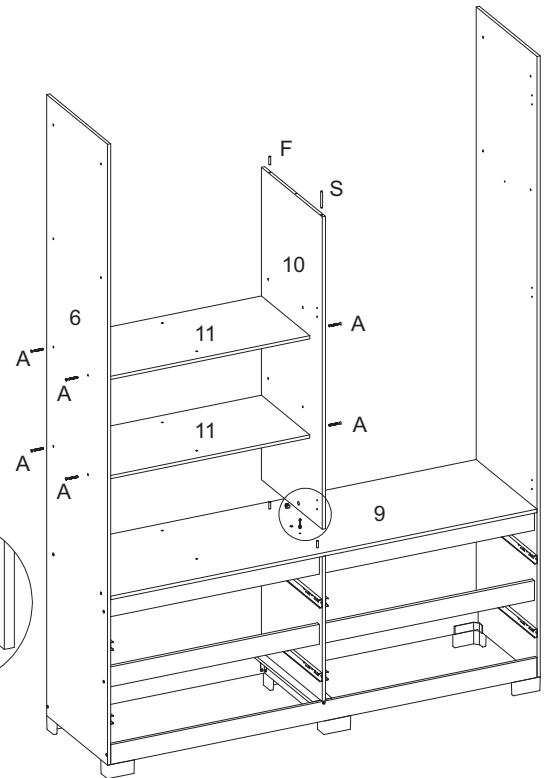
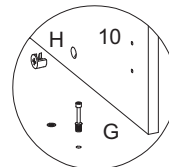
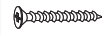

10° PASSO - Fixar peça 13 nas peças 6, 8 e 10

10° STEP - Fix parts 9 to parts 12 and 13

10° PASO - Fijar la pieza 13 a las piezas 6, 8 y 10.

A

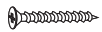

G

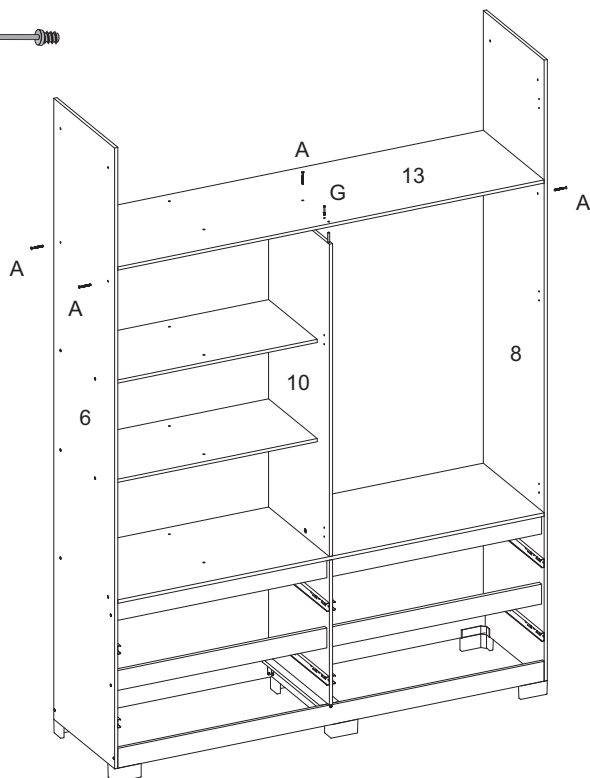
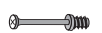

11° PASSO - Fixar peças 12 nas peças 9, 11 e 13

11° STEP - Fix parts 12 to parts 9, 11 and 13.

11° PASO - Fijar las piezas 12 a las piezas 9, 11 y 13.

A

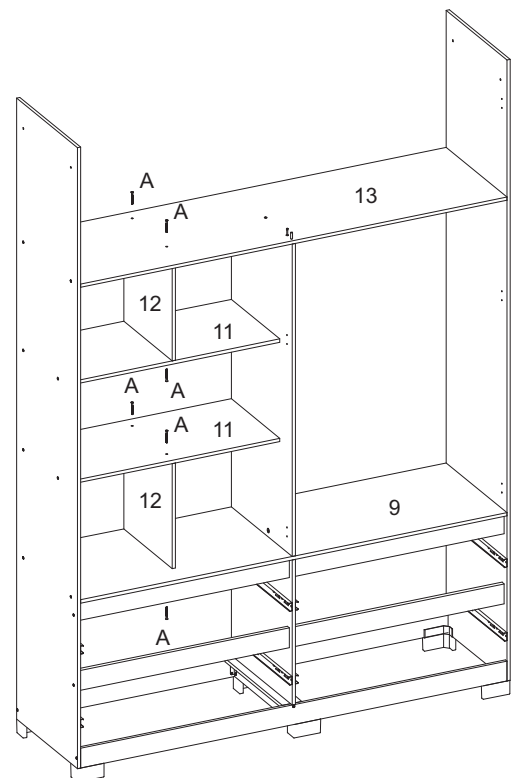

12º PASSO - Fixar peças 14 e 15 nas peças 6,8 e 13

12º STEP - Fix parts 14 and 15 to parts 6, 8 and 13.

12º PASO - Fijar las piezas 14 y 15 a las piezas 6, 8 y 13.

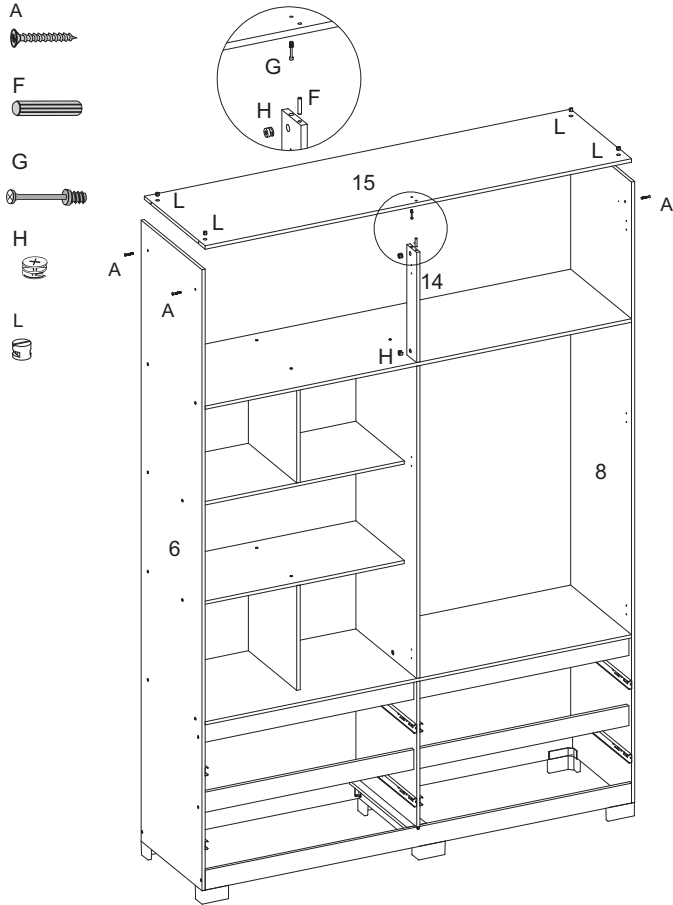

13º PASSO - Fixar as peça 16 nas peças 6,8 e 15

13º STEP - Fix part 16 to parts 6, 8 and 15

13º PASO - Fijar la parte 16 a las partes 6, 8 y 15

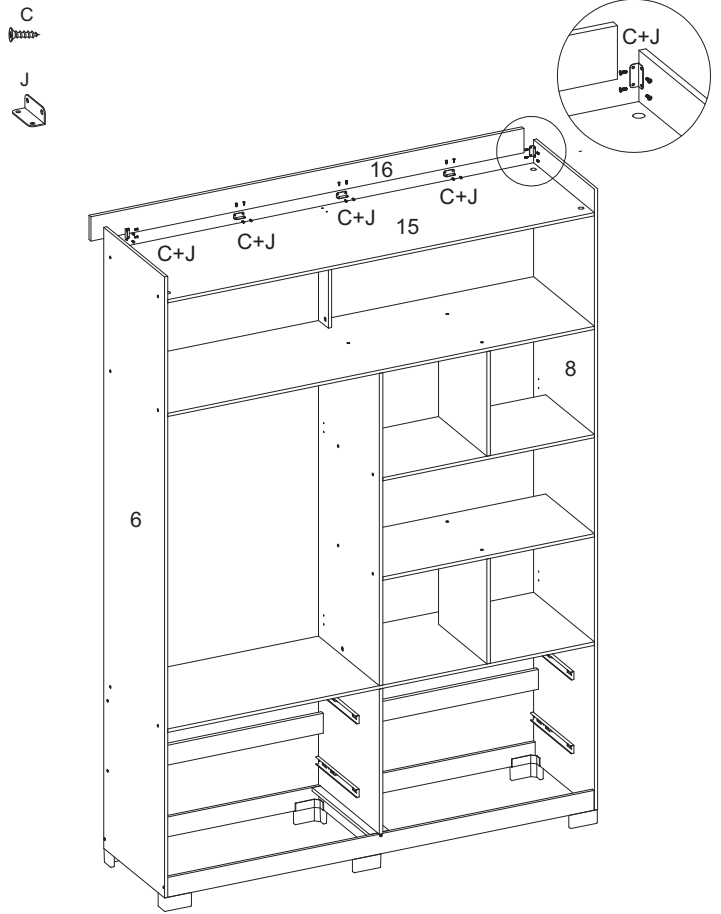

14º PASSO - Fixar peças 24 na parte de trás do produto

14º STEP - Fix parts 24 on the back of the product

14º PASO - Fijar las piezas 24 en la parte trasera del producto.

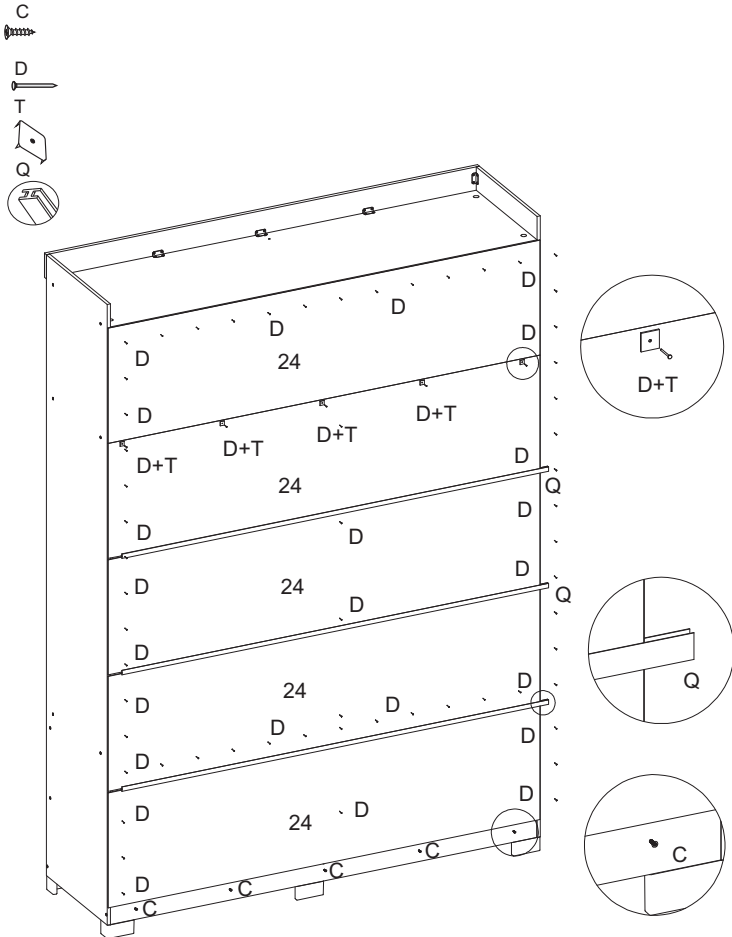

15º PASSO - Fixar os acessórios

15º STEP - Fix the accessories

15º PASO - Fijar los accesorios

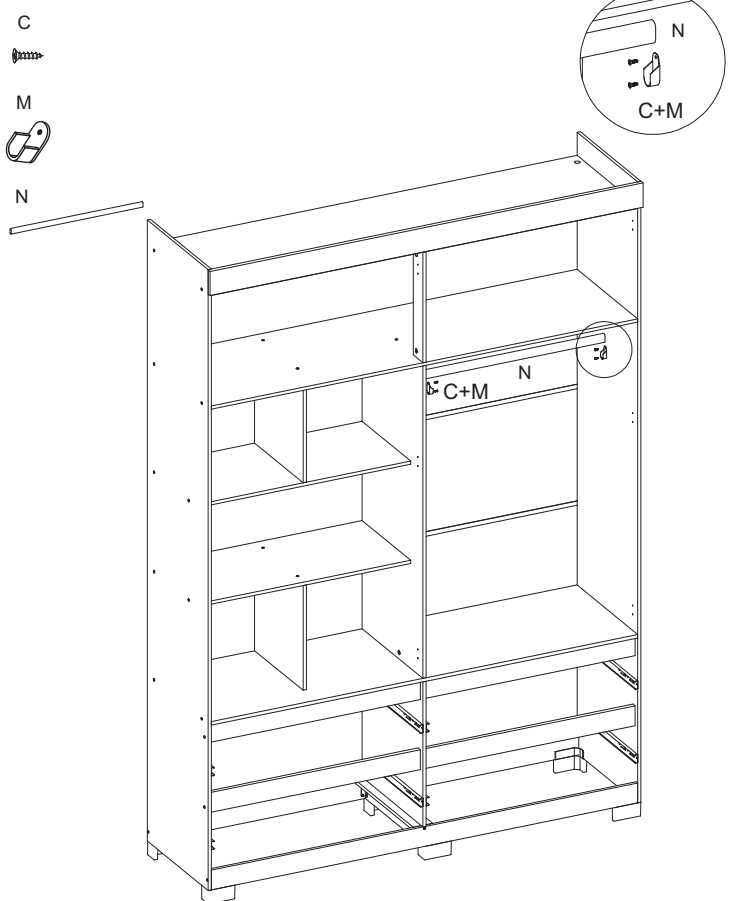

16° PASSO - Fixar peças 17 nas peças 6,8 e 10

16° STEP - Fix parts 17 to parts 6,8 and 10

16° PASO - Fijar las piezas 17 a las piezas 6,8 y 10

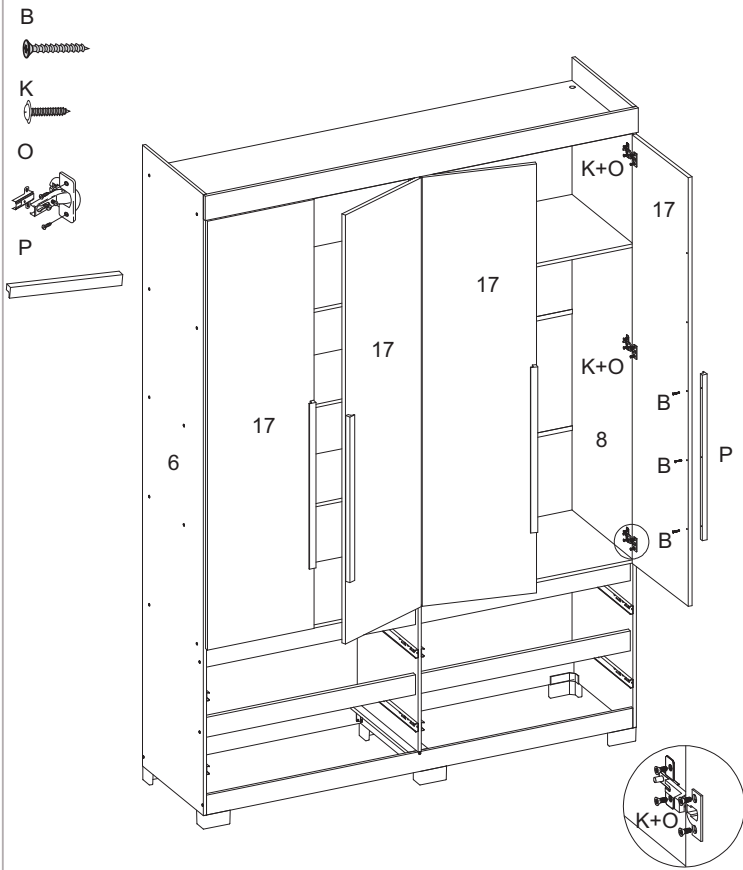

17° PASSO - Fixar peças 20 nas peça 18/19 e 21

17° STEP - Fix parts 20 to parts 18/19 and 21

17° PASO - Fijar las piezas 20 con las piezas 18/19 y 21

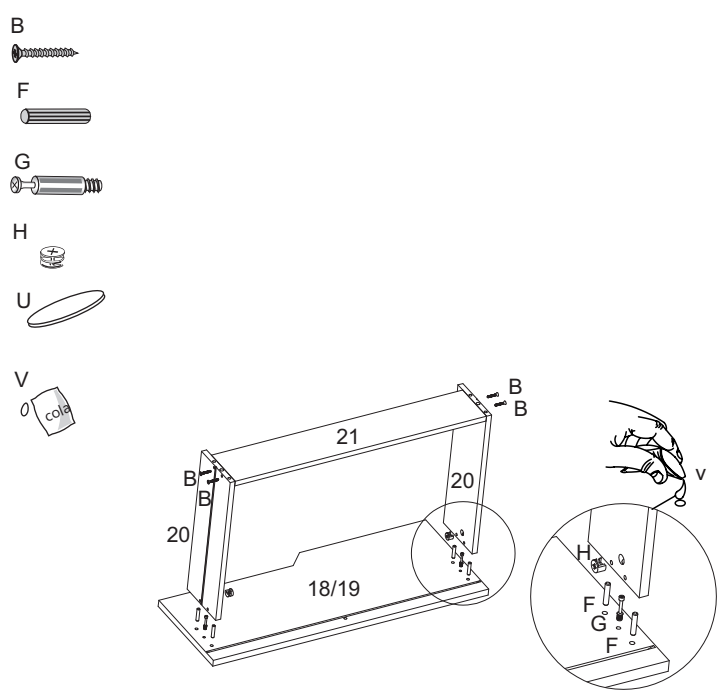

18° PASSO - Fixar peça 23 nas peças 20 e 21

18° STEP - Fix part 23 to parts 20 and 21

18° PASO - Fijar la parte 23 a las partes 20 y 21

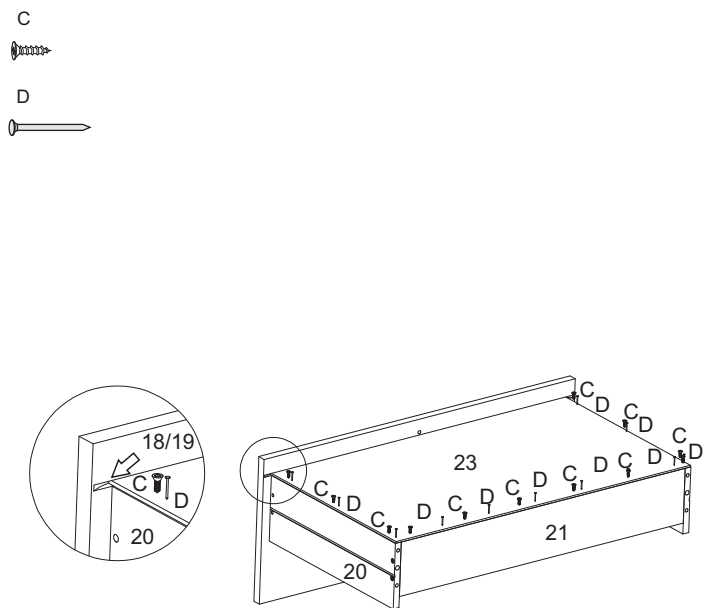

19° PASSO - Fixar peça 22 na peça 21

19° STEP - Fix part 22 to part 21

19° PASO - Fijar la parte 22 a la parte 21

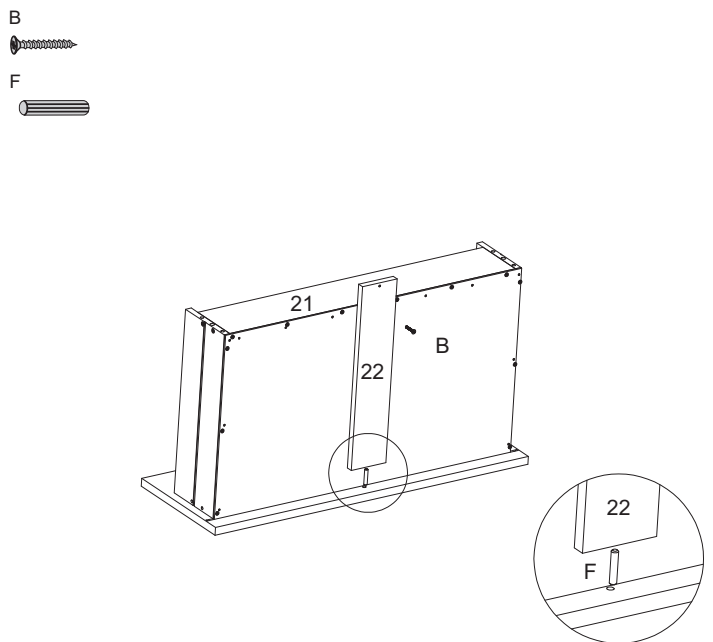

20° PASSO - Fixar os acessórios nas peças 20

20° STEP - Fix accessories to parts 20

20° PASO - Fijar accesorios en las piezas 20

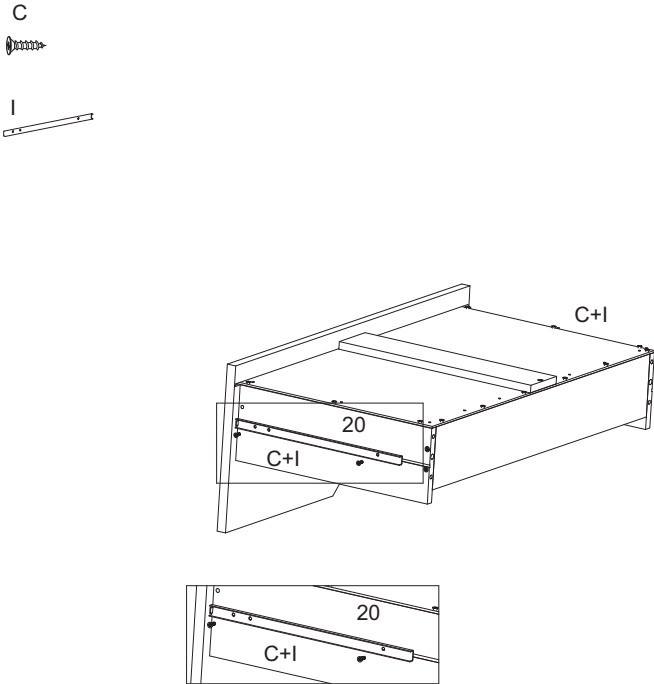

21° PASSO - Encaixar as gaveta no produto

21° STEP - Insert the drawers in the product

21° PASO - Introducir los cajones en el producto

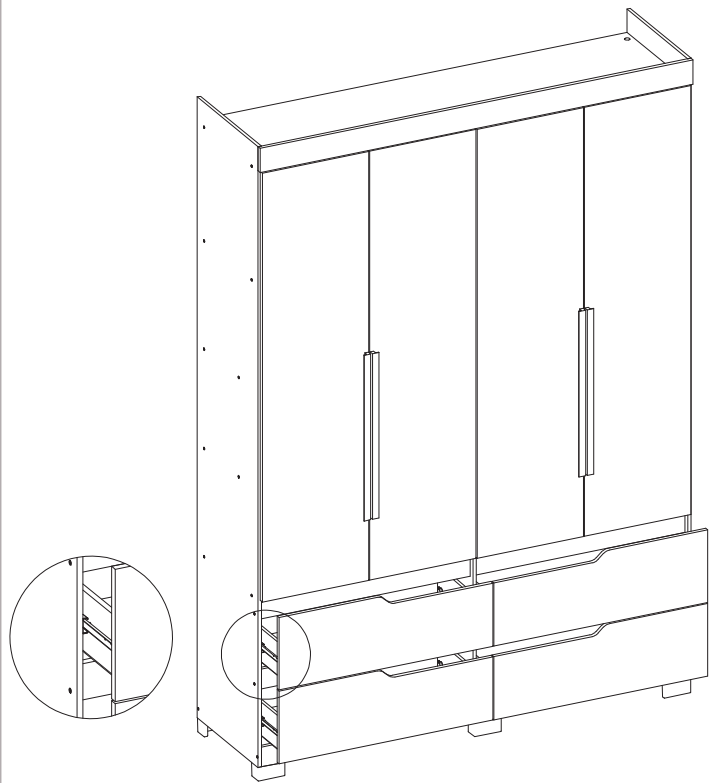

Montagem para o produto que cotem espelhos
Assembly for products with mirrors
Montaje para productos con espejos

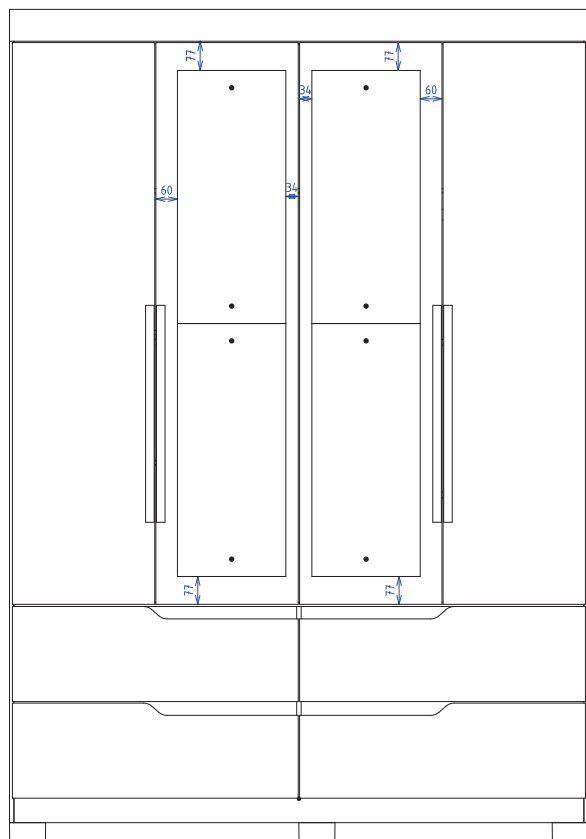

Aspecto final-do produto

Aspecto final-del producto.

Final appearance of the product

