

# HENN

Ind. e Com. de Móveis Henn  
Mondai - SC - Brasil

+55 49 3674.3500

@moveishenn  
www.henn.com.br

## INSTRUÇÕES DE MONTAGEM

INSTRUCCIONES DE MONTAJE  
ASSEMBLY INSTRUCTIONS

### Cozinha Compacta 5 Peças com Balcão com Tampo Aurora

☐ CE735-35 - Duna/Cristal

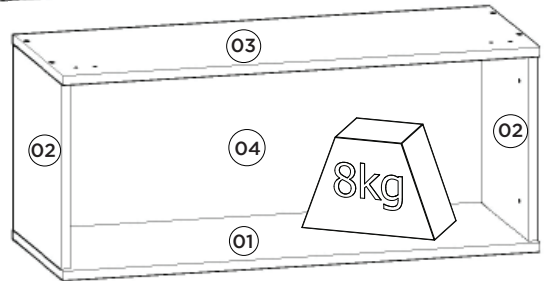
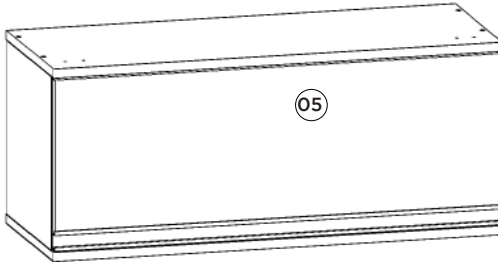

Pesos máximos recomendados  
com carga distribuída  
Peso máximo recomendado com  
a carga distribuída  
Recommended maximum weight  
with distributed load.

Requisitos para montagem  
Requisitos para la montaje  
Assembly Requirements

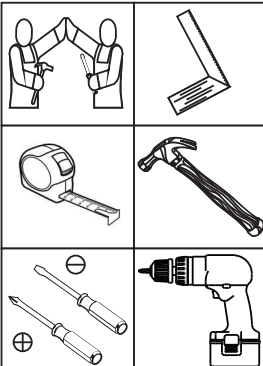

Imagens meramente ilustrativas  
Imágenes meramente ilustrativas  
Images for illustration only

#### AVISO

Para limpeza de seu móvel, use uma flanela seca ou umedecida, e não utilize produtos químicos que possam danificar seu produto.

#### SISTEMA DE MONTAGEM

O sistema de montagem dos produtos, funciona de acordo com a ordem crescente dos números indicados no desenho. Ex: 01, 02, 03, 04... até a conclusão da montagem.

#### ASSISTÊNCIA TÉCNICA

Para solicitação de Assistência Técnica você consumidor deverá entrar em contato com o Lojista a qual você realizou a compra deste produto e solicitar a assistência técnica das peças avariadas. A garantia abrange todas as peças, partes e componentes que eventualmente venham apresentar defeito de fabricação no prazo de 03 (três) meses, contando a partir da entrega do produto ao consumidor, mediante nota fiscal de compra. Se houver qualquer alteração na estrutura do produto ou ocorrer defeito por negligência do montador/consumidor em relação a instrução de montagem e manuseio, não será fornecido assistência técnica gratuita.

#### ADVERTENCIA

Para limpieza de su móvil, use una flanela seca o húmeda, y no utilice productos químicos que puedan dañar su producto.

#### SISTEMA DE MONTAJE

El sistema de montaje de los productos funciona de acuerdo con el orden creciente de los números indicados en el dibujo. Ej.: 01, 02, 03, 04... hasta la conclusión del montaje.

#### ASISTENCIA TÉCNICA

Para solicitar Asistencia Técnica, el consumidor debe comunicarse con el Comercio que usted realizó la compra de este producto y solicita asistencia técnica para las partes dañadas. La garantía cubre todas las partes, piezas y componentes que eventualmente puedan presentar defecto de fabricación en el plazo de 03 (tres) meses, contados a partir de la entrega del producto al consumidor, mediante factura de compra. Si se produce algún cambio en la estructura del producto o se produce un defecto por negligencia del montador/consumidor en relación con las instrucciones de montaje y manipulación, no se prestará asistencia técnica gratuita.

#### NOTICE

To clean your furniture, use a dry or wet cloth, and do not use chemicals that may damage your product.

#### ASSEMBLY SYSTEM

The products' assembly system works according to the increasing order of the indicated numbers. For example: 01, 02, 03, 04 ... to the end of the assembly.

#### TECHNICAL ASSISTANCE

To request Technical Assistance, the consumer must contact the retailer from whom you purchased this product and request technical assistance for the damaged parts. The warranty covers all parts, parts and components that may eventually present a manufacturing defect within a period of 03 (three) months, counting from the delivery of the product to the consumer, by means of a purchase invoice. If there is any change in the structure of the product or defect occurs due to negligence of the assembler/consumer in relation to the assembly and handling instruction, free technical assistance will not be provided.

1º

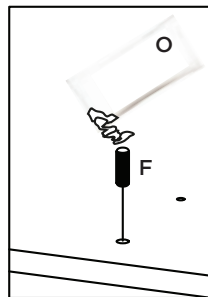
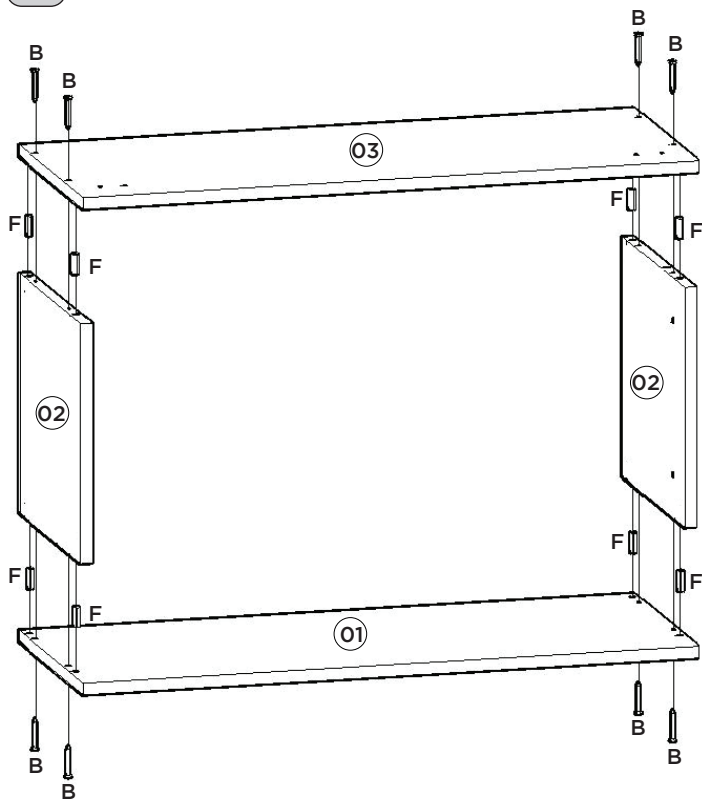

Utilizar o sachê de cola (O) em todas as cavilhas (F) do produto.

Con el pegamento sobre (O) en todos los pernos (F) producto.

Use the glue sachet (O) on all the pegs (F) of the product.

2º

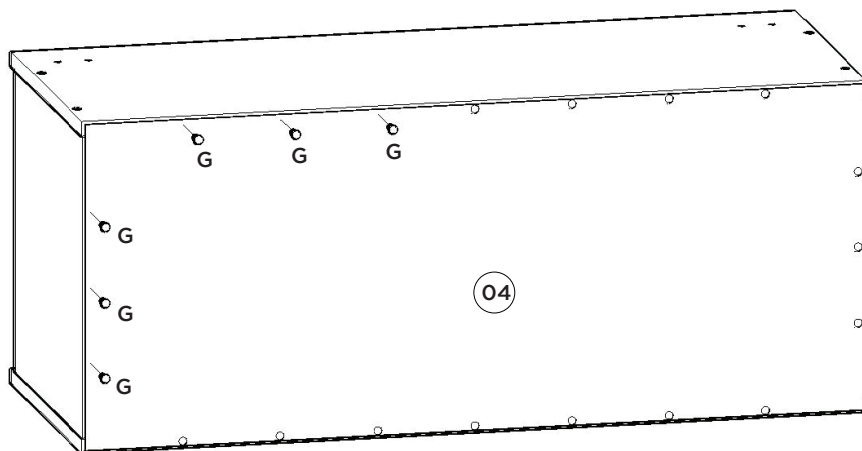

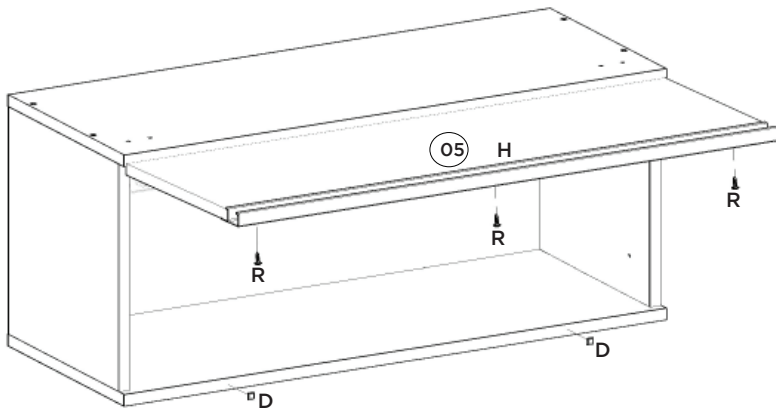
3<sup>o</sup>

Video: Instalar e regular Dobradiças

Video: Instale y ajuste las bisagras

Video: Install and adjust hinges

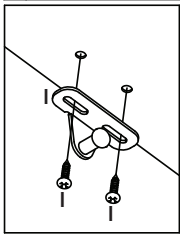
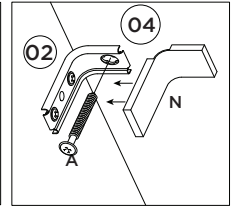
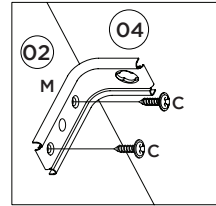
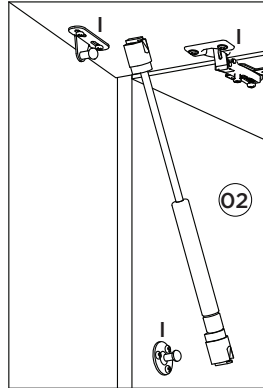
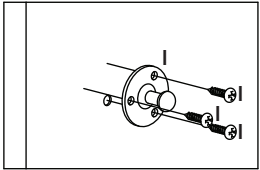
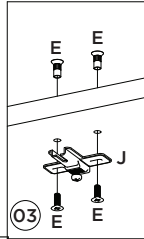
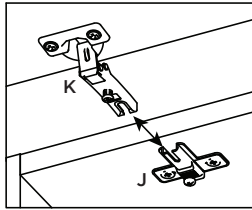
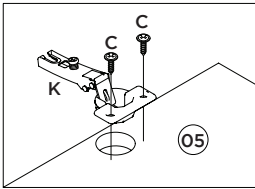

Video: Dicas para instalar o Kit Pistão à Gás

Video: Consejos para instalar el kit de pistón de gas

Video: Tips for installing the Gas Piston Kit

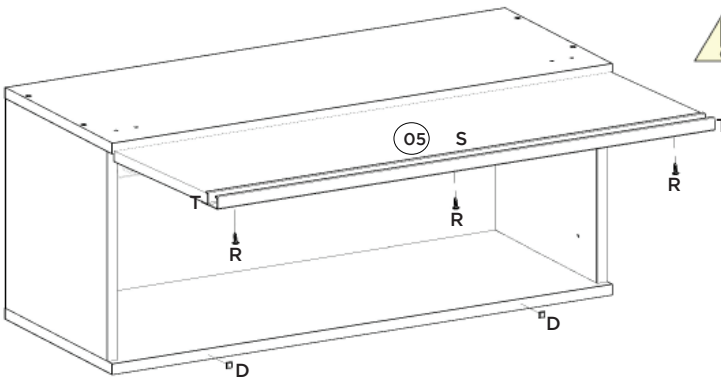

Somente para (C54-139)





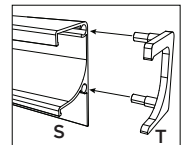







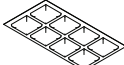

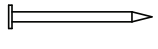

Solo para (C54-139)

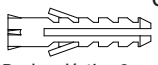
Only for (C54-139)

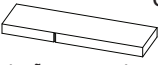

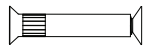

Item	Caixa Caja Box	Qtd Ctd Qty	Descrição   Descripción   Description	Medidas (mm)   Dimensions (mm)   Size (measurements) (mm)
01	1/1	01	Base   Base   Base	800x310x15
02	1/1	02	Lateral Direita Esquerda   Lateral Derecha Izquierda   Right Side Left	307x295x15
03	1/1	01	Tampo   Tapa   Top	800x310x15
04	1/1	01	Fundo   Fondo   Bottom	792x331x3
05	1/1	01	Porta Basculante   Puerta Basculante   Basculating Door	795x274x15
05	1/1	01	Porta Basculante   Puerta Basculante   Busculating Door (Somente para C54-139)	796x277x15

Ferragens | Herrajes | Hardware

<b>A</b>  Parafuso 5,0x50mm FLA. Tornillo 5,0x50mm FLA. Screw 5,0x50mm FLA.	02x	<b>B</b>  Parafuso 3,5x40mm CHT. Tornillo 3,5x40mm CHT. Screw 3,5x40mm CHT.	08x	<b>C</b>  Parafuso 3,5x14mm FLA. Tornillo 3,5x14mm FLA. Screw 3,5x14mm FLA.	08x	<b>D</b>  Batente PVC para Porta Parada de PVC para Puerta PVC Door Stop	02x	<b>E</b>  Parafuso União 15mm Tornillo Unión 15mm Union Screw 15mm	04x
<b>F</b>  Cavilha 8x25mm Cinta 8x25mm Dowel 8x25mm	08x	<b>G</b>  Prego 10x10mm Clavo 10x10mm Nail 10x10mm	20x	<b>H</b>  Puxador Alum. MOV 795mm Tirador Alum. MOV 795mm Handle Alum. MOV 795mm	01x	<b>I</b>  Kit Pistão a Gás 60N Kit Pistón a Gas 60N 60N Gas Piston Kit	01x	<b>J</b>  Calço metal Super Alto 8mm Calzado metálico Super Alto 8mm Super 8mm metal chock	02x
<b>K</b>  Dobradiça metal 35mm Alta Bisagras metálicas 35mm Alta Metal hinge 35mm High	02x	<b>L</b>  Bucha plástica 8mm Bucha de plástico 8mm 8mm plastic bushing	02x	<b>M</b>  Suporte de fixação Soporte de fijación Mounting bracket	02x	<b>N</b>  Proteção para cantoneira Ángulo de protección Protection angle	02x	<b>O</b>  Sachê de cola Bolsa de pegamento Glue bag	01x
<b>P</b>  Adesivo tampa parafuso 10mm Adhesivo tapón de tornillo 10mm Bolt cover adhesive 10mm	08x	<b>Q</b>  Parafuso União 30mm Tornillo Unión 30mm Union Screw 30mm	04x	<b>R</b>  Parafuso 3,5x12mm CHT. Tornillo 3,5x12mm CHT. Screw 3,5x12mm CHT.	03x	<b>S</b>  Puxador MOV4083 - 792mm Tirador MOV4083 - 792mm MOV4083 - 792mm Handle	01x	<b>T</b>  Kit Ponteira Plastica MOV4083 Kit de punta de plástico MOV4083 Plastic Tip Kit MOV4083	01x

 O parafuso (Q) deve ser usada somente quando este módulo for acoplado a outro módulo componível Henn.

 El tornillo (Q) se debe utilizar sólo cuando el módulo está conectado a otro módulo componible Henn.

 The screw (Q) should be used only when this module is attached to another Henn modular module.

**RECOMENDAÇÃO**  
Para fixar o móvel na parede usar o suporte de fixação (M), o parafuso 3,5x14mm FLA (C), a Bucha 8mm (L) e o parafuso 5,0x50mm FLA (A).

**RECOMENDACIÓN**  
Para conectar el móvil a la pared con el soporte (M), tornillo 3,5 x14mm FLA (C), el casquillo de 8 mm (L) y el 5,0 x50mm tornillo FLA (A).

**RECOMMENDATION**  
To fix the furniture to the wall use the fixing bracket (M), the 3.5x14mm FLA (C) screw, the 8mm bushing (L) and the 5.0x50mm FLA (A).

**HENN**

Aéreo O3 Portas 1200mm Connect | Aéreo O3 Puertas 1200mm Connect |  
Aerial O3 Doors 1200mm Connect

Referência/Cor  
c C56-35 Duna/Cristal  
c C56-42 Fendi  
c C56-139 Off White

Requisitos para montagem  
Requisitos para la montaje  
Assembly Requirements



Imagens meramente ilustrativas, não acompanha o produto.  
Imágenes ilustrativas, no incluidas con el producto.  
Illustrative images, not included with the product.

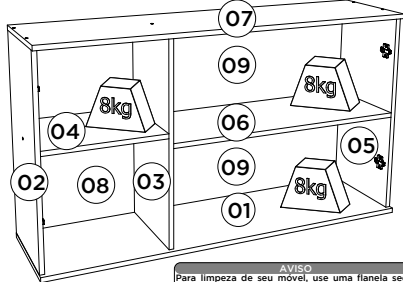
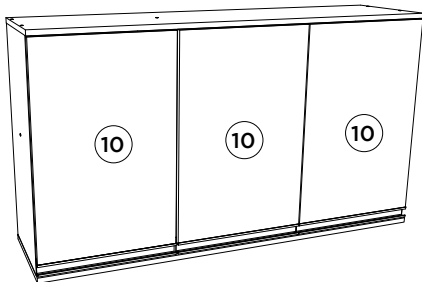

Pesos máximos recomendados com carga distribuída  
Peso máximo recomendado con la carga distribuída  
Recommended maximum weight with distributed load.

**AVISO**  
Para limpeza de seu móvel, use uma flanela seca ou umedecida, e não utilize produtos químicos que possam danificar seu produto.

**SISTEMA DE MONTAGEM**  
O sistema de montagem dos produtos, funciona de acordo com a ordem crescente dos números indicados no desenho. Ex: 01, 02, 03, 04... até a conclusão da montagem.

**ASSISTÊNCIA TÉCNICA**

Para solicitação de Assistência Técnica você consumidor deverá entrar em contato com o Lojista o qual você realizou a compra deste produto e solicitar a assistência técnica das peças avariadas. A garantia abrange todas as peças, partes e componentes que eventualmente venham apresentar defeito de fabricação no prazo de 03 (três) meses, contando a partir da entrega do produto ao consumidor, mediante nota fiscal de compra. Se houver qualquer alteração na estrutura do produto ou ocorrer defeito por negligência do montador/consumidor em relação a instrução de montagem e manuseio, não será fornecido assistência técnica gratuita.

**ADVERTÊNCIA**  
Para limpeza de sua furniture, use una flanela seca o húmeda, y no utilice productos químicos que puedan dañar su producto.

**SISTEMA DE MONTAJE**  
El sistema de montaje de los productos funciona de acuerdo con el orden creciente de los números indicados en el dibujo. Ej: 01, 02, 03, 04... hasta la conclusión del montaje.

**ASSISTENCIA TÉCNICA**

Para solicitar Assistência Técnica, el consumidor debe comunicarse con el Comercio que usted realizó la compra de este producto y solicita asistencia técnica para las partes avariadas. La garantía cubre todas las partes, piezas y componentes que eventualmente puedan presentar defecto de fabricación en el plazo de 03 (tres) meses, contados a partir de la entrega del producto al consumidor, mediante factura de compra. Si se produce algún cambio en la estructura del producto o se produce un defecto por negligencia del montador/consumidor en relación con las instrucciones de montaje y manipulación, no se prestará asistencia técnica gratuita.

**NOTICE**  
To clean your furniture, use a dry or wet cloth, and do not use chemicals that may damage your product.

Lista de Peças | Lista de piezas | List of parts

Item	Caixa Caja Box	Qty	Descrição   Descripción   Description	Medidas (mm)   Dimensions (mm)   Size (measurements) (mm)
01	1/1	01	Base   Base   Base	1200x310x15
02	1/1	01	Lateral Esquerda   Lateral Izquierda   Right Left	645x295x15
03	1/1	01	Divisão   División   Division	645x295x15
04	1/1	01	Prateleira Menor   Estante Pequeno   Smaller Shelf	381x295x15
05	1/1	01	Lateral Direita   Lateral Derecha   Right Side	645x295x15
06	1/1	01	Prateleira   Estante   Shelf	772x295x15
07	1/1	01	Tampo   Tapa   Top	1200x310x15
08	1/1	01	Fundo Lateral   Fondo Lateral   Lateral Background	669x400x3
09	1/1	02	Fundo   Fondo   Bottom	791x334x3
10	1/1	03	Porta   Puerta   Door	612x396x15
10	1/1	03	Porta   Puerta   Door (Somente para C56-139)	616x396x15

Ferragens | Herrajes | Hardware

<b>A</b> 03	<b>B</b> 14	<b>C</b> 30	<b>D</b> 51	<b>E</b> 20	<b>F</b> 06
Parafuso 5,0x50mm FLA. Tornillo 5,0x50mm FLA. Screw 5,0x50mm FLA.	Parafuso 3,5x40mm CHT. Tornillo 3,5x40mm CHT. Screw 3,5x40mm CHT.	Parafuso 3,5x14mm FLA. Tornillo 3,5x14mm FLA. Screw 3,5x14mm FLA.	Prego 10x10mm Clavo 10x10mm Nail 10x10mm	Cavilha 8x25mm Cinta 8x25mm Dowel 8x25mm	Calço metal alto 3mm Calzado metálico alto 3mm 3mm high metal chock
<b>G</b> 06	<b>H</b> 06	<b>I</b> 03	<b>J</b> 03	<b>K</b> 03	<b>L</b> 04
Dobradilha metal 35mm Colo Baixo Bisagra de metal 35mm Colo Bajo Metal hinge 35mm Colo Low	Parafuso 3,5x12mm CHT. Tornillo 3,5x12mm CHT. Screw 3,5x12mm CHT.	Bucha plástica 8mm Bucha de plástico 8mm 8mm plastic bushing	Suporte de fixação Soporte de fijación Mounting bracket	Proteção para cantoneira Angulo de protección Protection angle	Parafuso União 30mm Tornillo Unión 30mm Union Screw 30mm
<b>M</b> 04	<b>N</b> 02	<b>O</b> 12	<b>P</b> 13	<b>Q</b> 03	<b>R</b> 01
Batente PVC para Porta Parada de PVC para Puerta PVC Door Stop	Sachê de cola Bolsa de pegamento Glue bag	Adesivo tapa parafuso 10mm Adhesivo tapón de tornillo 10mm Bolt cover adhesive 10mm	Fixador de fundos Fijador de fondos Bottom fixer	Giz de correção Tiza de corrección Chalk of correction	<b>HENN</b> Etiqueta resinada Henn Etiqueta resinada Henn Henn resin label

**ASSEMBLY SYSTEM**  
The products' assembly system works according to the increasing order of the indicated numbers. For example: 01, 02, 03, 04 ... to the end of the assembly.

**TECHNICAL ASSISTANCE**

To request Technical Assistance, the consumer must contact the retailer from whom you purchased this product and request technical assistance for the damaged parts. The warranty covers all parts, parts and components that may eventually present a manufacturing defect within a period of 03 (three) months, counting from the delivery of the product to the consumer, by means of a purchase invoice. If there is any change in the structure of the product or defect occurs due to negligence of the assembler/consumer in relation to the assembly and handling instruction, free technical assistance will not be provided.

**S** 03 | **T** 03

Puxador MOV 396mm  
Tirador MOV 396mm  
MOV 396mm Handle

Puxador MOV4083 - 392mm  
Tirador MOV4083 - 392mm  
MOV4083 - 392mm Handle

**U** 01

Kit Ponteira Plástica MOV4083  
Kit de punta de plástico MOV4083  
Plastic Tip Kit MOV4083

O parafuso (L) deve ser usada somente quando este módulo for acoplado a outro módulo componível Henn.

El tornillo (L) se debe utilizar sólo cuando el módulo está conectado a otro módulo componible Henn.

The screw (L) should be used only when this module is attached to another Henn modular module.

**RECOMENDAÇÃO**  
Para fixar o móvel na parede usar o suporte de fixação (J), o parafuso 3,5x14mm FLA (C), a Bucha 8mm (I) e o parafuso 5,0x50mm FLA (A).

**RECOMENDACIÓN**  
Para conectar el móvil a la pared con el soporte (J), tornillo 3,5 x14mm FLA (C), el casquillo de 8 mm (I) y el 5,0 x50mm tornillo FLA (A).

**RECOMMENDATION**  
To fix the furniture to the wall use the fixing bracket (J), the 3.5x14mm FLA (C) screw, the 8mm bushing (I) and the 5.0x50mm FLA (A) screw.

1

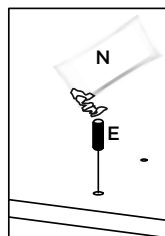
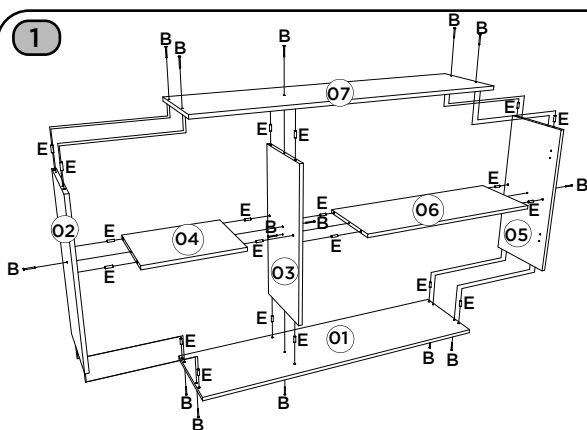

Utilizar o sachê de cola (N) em todas as cavilhas (E) do produto.

Con el pegamento sobre (N) en todos los pernos (E) producto.

Use the glue sachet (N) on all the pegs (E) of the product.

2

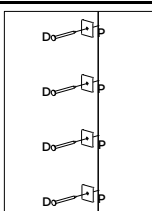
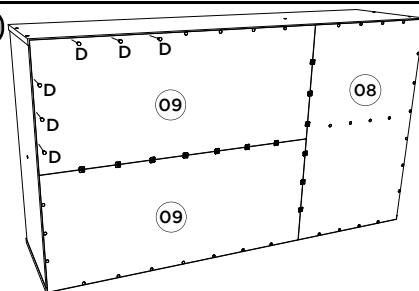

Para saber mais sobre como fixar o móvel de maneira correta, acesse:

Para obtener más información sobre cómo arreglar los muebles correctamente, visite:

To learn more about how to fix the furniture correctly, visit:



<http://bit.ly/guia-de-fixacao-henn>

3



Imprescindível a fixação do produto na parede.

Es imprescindible la fijación del producto en la pared.

Indispensable to fix the product on the wall.

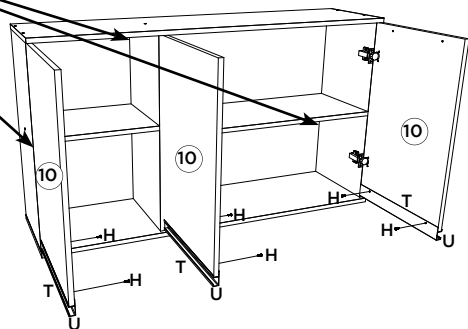
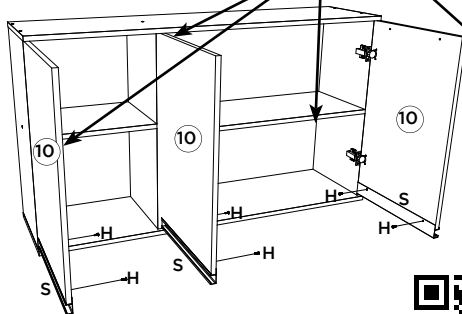
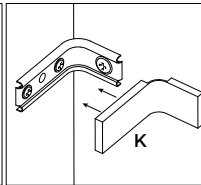
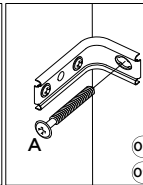
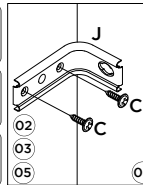

Video: Instalar e regular Dobradiças

Video: Instale y ajuste las bisagras

Video: Install and adjust hinges



Somente para (C56-139)

Solo para (C56-139)

Only for (C56-139)

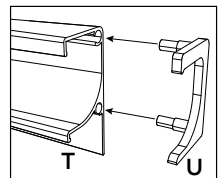

2

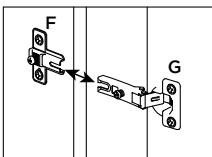
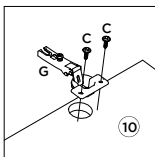
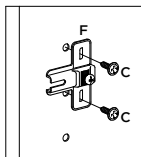

**HENN**Ind. e Com. de Móveis Henn  
Mondai - SC - Brasil

☎ +55 49 3674.3500

📧 @moveishenn  
www.henn.com.br**INSTRUÇÕES DE MONTAGEM****INSTRUCCIONES DE MONTAJE  
ASSEMBLY INSTRUCTIONS****BALCÃO 2 PORTAS 800MM CONNECT | BALCÓN 2 PUERTAS 800MM CONNECT |  
BALCONY 2 DOORS 800MM CONNECT****Referência/Cor**

- C64-35 - Duna/Cristal  
 C64-42 - Fendi  
 C64-139 - Off White

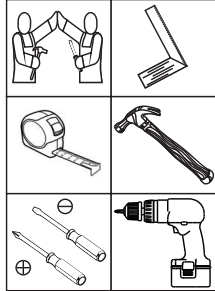
**Requisitos para montagem  
Requisitos para la montaje  
Assembly Requirements**

Imagens meramente ilustrativas, não acompanha o produto.  
 Imágenes ilustrativas, no incluidas con el producto.  
 Illustrative images, not included with the product.

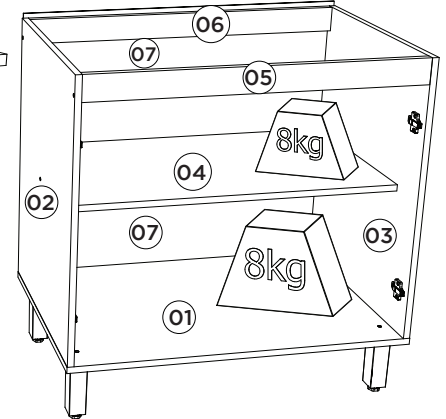
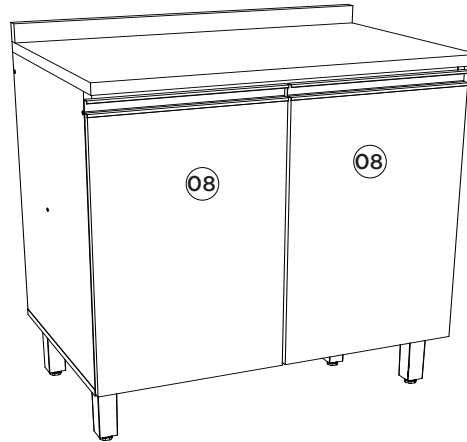

**Pesos máximos recomendados com carga distribuída  
 Peso máximo recomendado con la carga distribuida  
 Recommended maximum weights with evenly distributed.**

**Lista de Peças | Lista de piezas | List of parts**

Item	Caixa Caja Box	Qtd Ctd Qty	Descrição   Descripción   Description	Medidas (mm)   Dimensions (mm)   Size (measurements) (mm)
01	1/1	01	Base   Base   Base	800x490x15
02	1/1	01	Lateral esquerda   Lateral izquierda   Left side	660x490x15
03	1/1	01	Lateral direita   Lateral derecha   Right side	660x490x15
04	1/1	01	Prateleira   Estante   Shelf	768x400x15
05	1/1	01	Travessa frontal   Travesaño frontal   Front crossbar	768x60x15
06	1/1	01	Travessa traseira   Travesaño trasero   Rear bumper	768x60x15
07	1/1	02	Fundo   Fondo   Bottom	792x341x3
08	1/1	02	Porta   Puerta   Door	625x396x15
08	1/1	02	Porta   Puerta   Door (Somente para C64-139)	629x396x15

**AVISO**  
 Para limpeza de seu móvel, use uma favela seca ou umedecida, e não utilize produtos químicos que possam danificar seu produto.

**SISTEMA DE MONTAGEM**  
 O sistema de montagem dos produtos, funciona de acordo com a ordem crescente dos números indicados no desenho. Ex: 01, 02, 03, 04... até a conclusão da montagem.

**ASSISTÊNCIA TÉCNICA**  
 Para solicitação de Assistência Técnica você consumidor deverá entrar em contato com o Lojista o qual você realizou a compra deste produto e solicitar a assistência técnica das peças avariadas. A garantia abrange todas as peças, partes e componentes que eventualmente venham apresentar defeito de fabricação no prazo de 03 (três) meses, contando a partir da entrega do produto ao consumidor, mediante nota fiscal de compra. Se houver qualquer alteração na estrutura do produto ou ocorrer defeito por negligência do montador/consumidor em relação a instrução de montagem e manuseio, não será fornecido assistência técnica gratuita.

**ADVERTENCIA**  
 Para limpieza de su móvil, use una favela seca o húmeda, y no utilice productos químicos que puedan dañar su producto.

**SISTEMA DE MONTAJE**  
 El sistema de montaje de los productos funciona de acuerdo con el orden creciente de los números indicados en el dibujo. Ej: 01, 02, 03, 04... hasta la conclusión del montaje.

**ASSISTENCIA TÉCNICA**  
 Para solicitar Asistencia Técnica, el consumidor debe comunicarse con el Comercio que usted realizó la compra de este producto y solicita asistencia técnica para las partes dañadas. La garantía cubre todas las partes, piezas y componentes que eventualmente puedan presentar defecto de fabricación en el plazo de 03 (tres) meses, contados a partir de la entrega del producto al consumidor, mediante factura de compra. Si se produce algún cambio en la estructura del producto o se produce un defecto por negligencia del montador/consumidor en relación con las instrucciones de montaje y manipulación, no se prestará asistencia técnica gratuita.

**NOTICE**  
 To clean your furniture, use a dry or wet cloth, and do not use chemicals that may damage your product.

**ASSEMBLY SYSTEM**  
 The products' assembly system works according to the increasing order of the indicated numbers. For example: 01, 02, 03, 04 ... to the end of the assembly.

**TECHNICAL ASSISTANCE**  
 To request Technical Assistance, the consumer must contact the retailer from whom you purchased this product and request technical assistance for the damaged parts. The warranty covers all parts, parts and components that may eventually present a manufacturing defect within a period of 03 (three) months, counting from the delivery of the product to the consumer, by means of a purchase invoice. If there is any change in the structure of the product or defect occurs due to negligence of the assembler/consumer in relation to the assembly and handling instruction, free technical assistance will not be provided.

**Ferragens | Herrajes | Hardware**

<b>A</b> Parafuso 7,0x40mm CHT. Tornillo 7,0x40mm CHT. Screw 7,0x40mm CHT.	<b>B</b> Parafuso 5,0x50mm FLA. Tornillo 5,0x50mm FLA. Screw 5,0x50mm FLA.	<b>C</b> Parafuso 4,5x50mm CHT. Tornillo 4,5x50mm CHT. Screw 4,5x50mm CHT.	<b>D</b> Parafuso 3,5x40mm CHT. Tornillo 3,5x40mm CHT. Screw 3,5x40mm CHT.	<b>E</b> Parafuso 3,5x14mm FLA. Tornillo 3,5x14mm FLA. Screw 3,5x14mm FLA.	<b>F</b> Parafuso 3,5x12mm CHT. Tornillo 3,5x12mm CHT. Screw 3,5x12mm CHT.	<b>G</b> Parafuso União 30mm Tornillo Unión 30mm Union Screw 30mm	<b>H</b> Cavilha 8x25mm Cinta 8x25mm Dowel 8x25mm
<b>I</b> Prego 10x10mm Clavo 10x10mm Nail 10x10mm	<b>J</b> Fixador de fundos Fijador de fondos Bottom fixer	<b>K</b> Cantoneira plástica Cantoneira plástica Plastic angle brackets	<b>L</b> Pé 145mm x 42mm Pie 145mm x 42mm Foot 145mm x 42mm	<b>M</b> Puxador MOV 396mm Tirador MOV 396mm MOV 396mm Handle	<b>N</b> Calço metal médio 0mm Calzón de metal medio 0mm Shim metal middle 0mm	<b>O</b> Dobradiça metal 35mm Colo Baixo Bisagra de metal 35mm Colo Bajo Metal hinge 35mm Colo Low	<b>P</b> Batente PVC para Porta Parada de PVC para Puerta PVC Door Stop
<b>Q</b> Buchta plástica 8mm Buchta de plástico 8mm 8mm plastic bushing	<b>R</b> Suporte de fixação Soporte de fijación Mounting bracket	<b>S</b> Proteção para cantoneira Ángulo de protección Protection angle	<b>T</b> Giz de correção Tiza de corrección Chalk of correction	<b>U</b> Sachê de cola Bolsa de pegamento Glue bag	<b>V</b> Adesivo tapa parafuso 10mm Adhesivo tapón de tornillo 10mm Bolt cover adhesive 10mm	<b>W</b> Adesivo tapa parafuso 17mm Adhesivo tapón de tornillo 17mm Bolt cover adhesive 17mm	<b>X</b> Puxador MOV4083 - 392mm Tirador MOV4083 - 392mm MOV4083 - 392mm Handle
<b>Y</b> Kit Ponta Plástica MOV4083 Kit de punta de plástico MOV4083 Plastic Tip Kit MOV4083							

O parafuso (G) deve ser usada somente quando este módulo for acoplado a outro módulo componível Henn.

El tornillo (G) se debe utilizar sólo cuando el módulo está conectado a otro módulo componible Henn.

The screw (G) should be used only when this module is attached to another Henn modular module.

**RECOMENDAÇÃO**

Para fixar o móvel na parede usar o suporte de fixação (R), o parafuso 3,5x14mm FLA (E), a Bucha 8mm (Q) e o parafuso 5,0x50mm FLA (B).

**RECOMENDACIÓN**

Para conectar el móvil a la pared con el soporte (R), tornillo 3,5 x14mm FLA (E), el casquillo de 8 mm (Q) y el 5,0 x50mm tornillo FLA (B).

**RECOMMENDATION**

To fix the furniture to the wall use the mounting bracket (R), the 3.5x14mm FLA (E) screw, the 8mm bushing (Q) and the 5.0x50mm FLA (B).

1

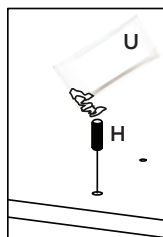
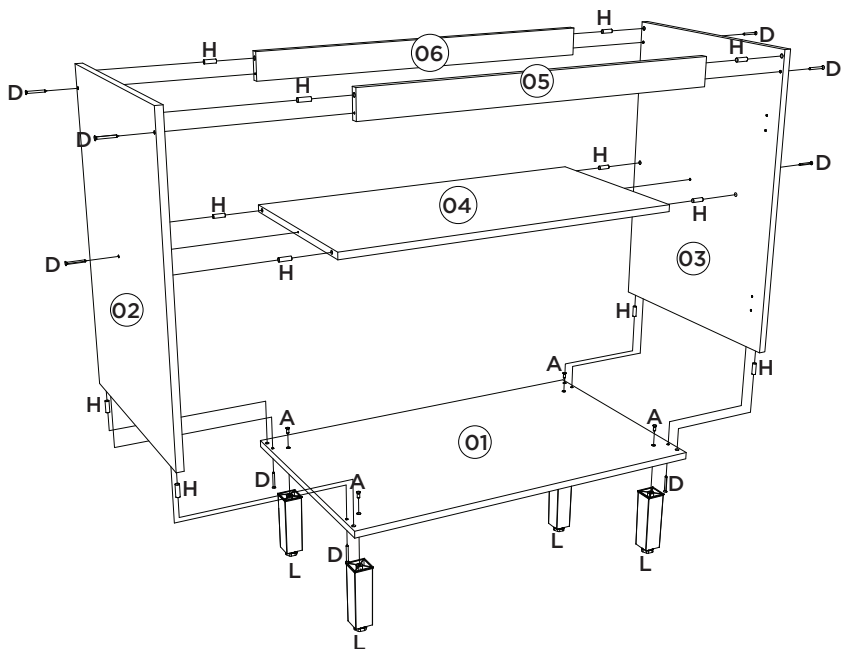

Utilizar o sachê de cola (U) em todas as cavilhas (H) do produto.

Con el pegamento sobre (U) en todos los pernos (H) producto.

Use the glue sachet (U) on all the pegs (H) of the product.

2

Esse tampo é opcional e é vendido separadamente (C904-33).

Esta vez es opcional y se vende por separado (C904-33).

This top is optional and is sold separately (C904-33).

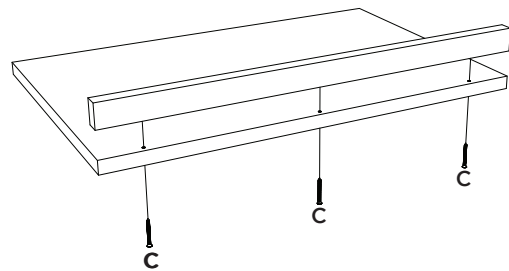

3

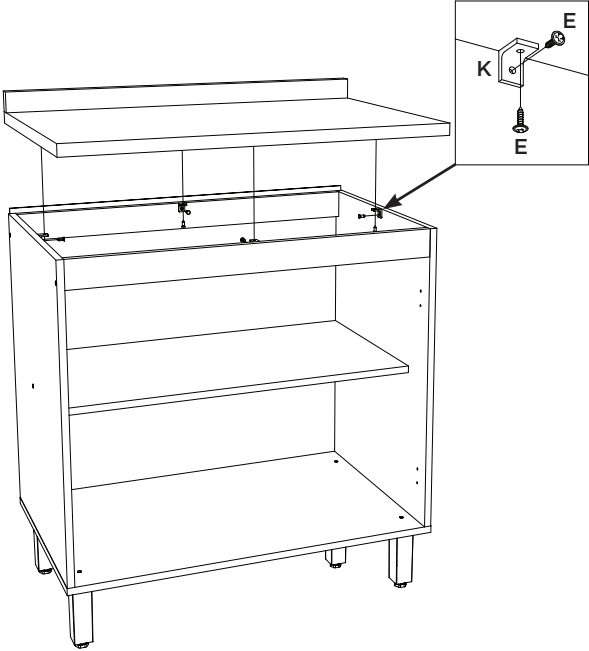

4

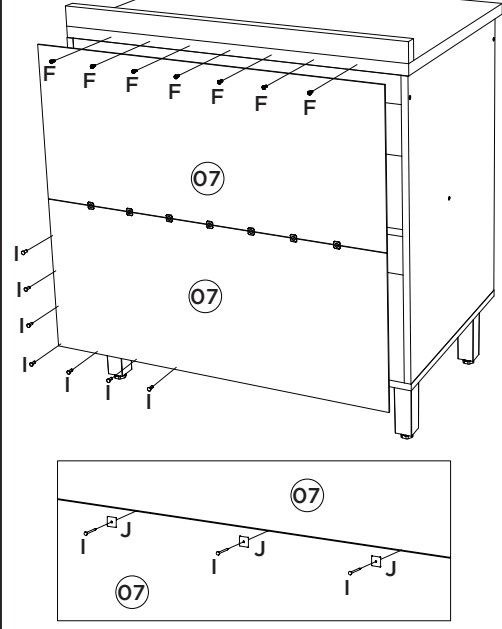

5

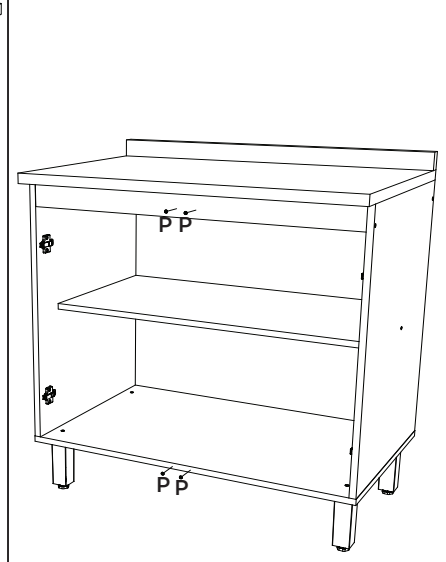

6

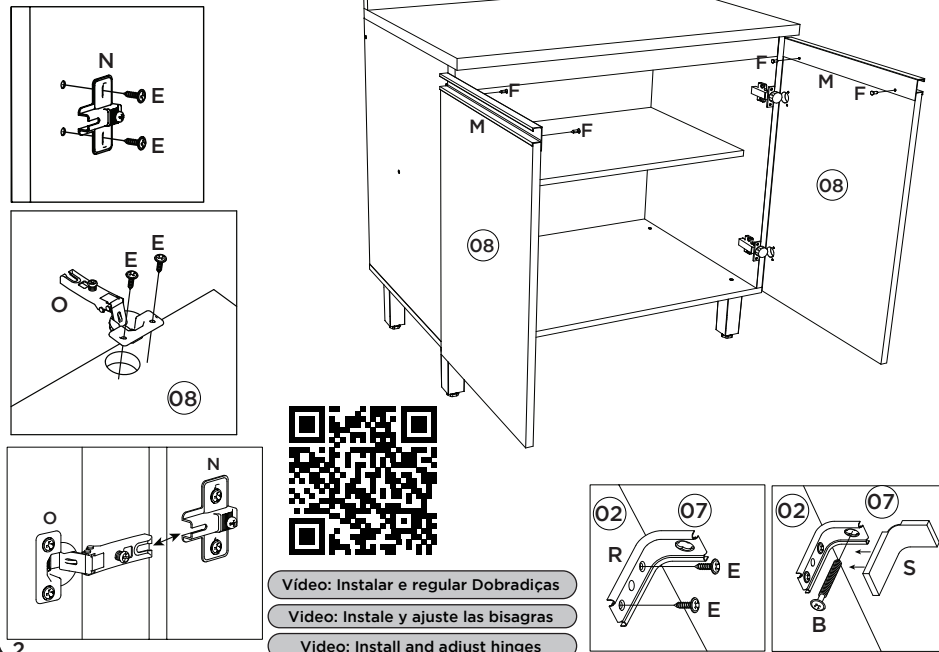

Video: Instalar e regular Dobradiças

Video: Instale y ajuste las bisagras

Video: Install and adjust hinges



Somente para (C64-139)

Solo para (C64-139)

Only for (C64-139)

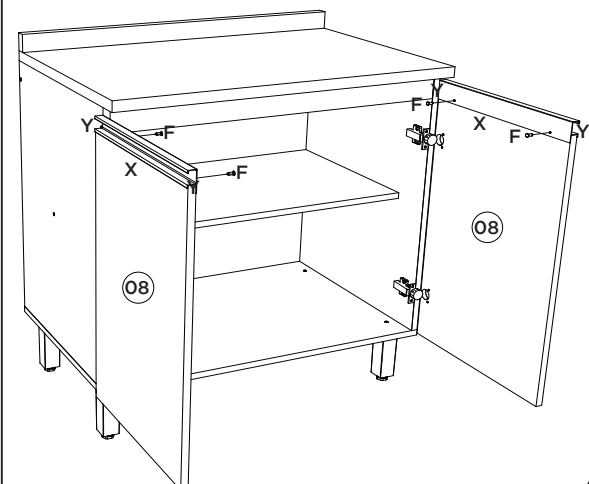
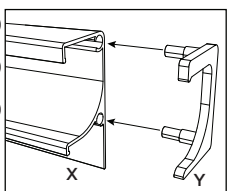



### Balcão Pia 02 Gavetas 03 Portas Connect

Pia Contador 02 Cajones 03 Puertas Connect | Balcony Pia 02 Drawers 03 Doors Connect

C66-35 Duna/Cristal | C66-42 Fendi

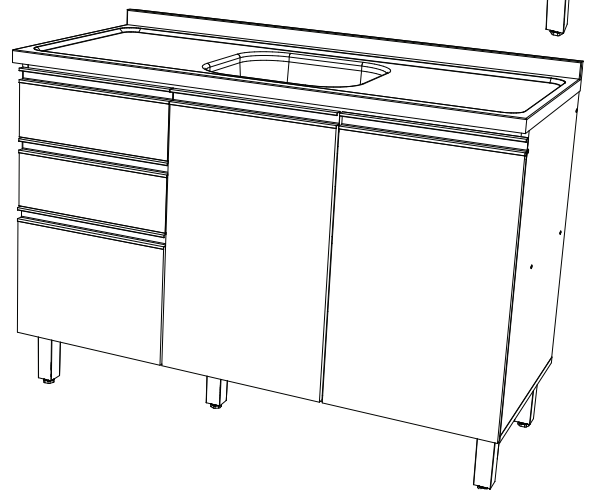
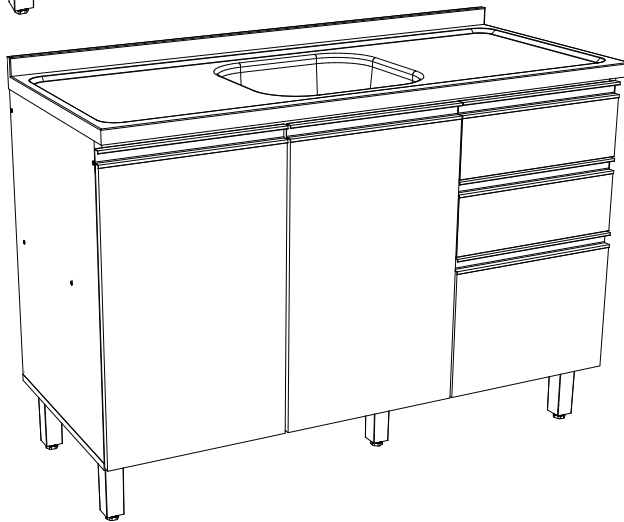
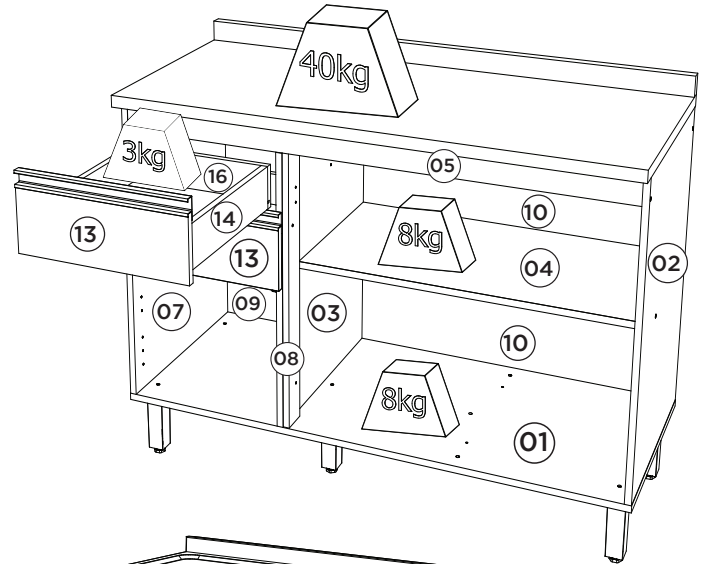
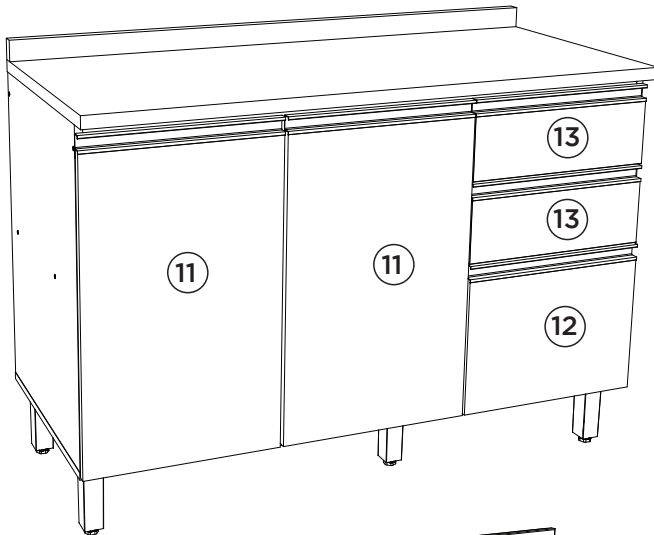

**Pesos máximos recomendados com carga distribuída**  
**Peso máximo recomendado con la carga distribuida**  
**Recommended maximum weights with evenly distributed.**

#### Requisitos para montagem Requisitos para la montaje Assembly Requirements

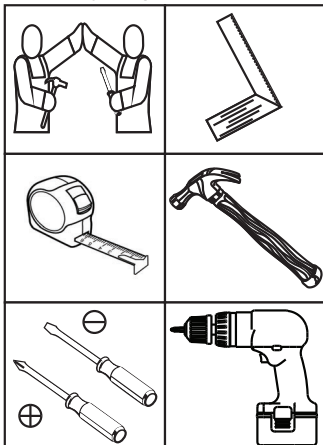

Imagens meramente ilustrativas, não acompanha o produto.  
Imágenes ilustrativas, no incluidas con el producto.  
Illustrative images, not included with the product.

#### AVISO

Para limpeza de seu móvel, use uma flanela seca ou umedecida, e não utilize produtos químicos que possam danificar seu produto.

#### SISTEMA DE MONTAGEM

O sistema de montagem dos produtos, funciona de acordo com a ordem crescente dos números indicados no desenho. Ex: 01, 02, 03, 04... até a conclusão da montagem.

#### ASSISTÊNCIA TÉCNICA

Para solicitação de Assistência Técnica você consumidor deverá entrar em contato com o Lojista o qual você realizou a compra deste produto e solicitar a assistência técnica das peças avariadas. A garantia abrange todas as peças, partes e componentes que eventualmente venham apresentar defeito de fabricação no prazo de 03 (três) meses, contando a partir da entrega do produto ao consumidor, mediante nota fiscal de compra. Se houver qualquer alteração na estrutura do produto ou ocorrer defeito por negligência do montador/consumidor em relação a instrução de montagem e manuseio, não será fornecido assistência técnica gratuita.

#### ADVERTENCIA

Para limpieza de su móvil, use una flanela seca o húmeda, y no utilice productos químicos que puedan dañar su producto.

#### SISTEMA DE MONTAJE

El sistema de montaje de los productos funciona de acuerdo con el orden creciente de los números indicados en el dibujo. Ej.: 01, 02, 03, 04... hasta la conclusión del montaje.

#### ASISTENCIA TÉCNICA

Para solicitar Asistencia Técnica, el consumidor debe comunicarse con el Comercio que usted realizó la compra de este producto y solicita asistencia técnica para las partes dañadas. La garantía cubre todas las partes, piezas y componentes que eventualmente puedan presentar defecto de fabricación en el plazo de 03 (tres) meses, contados a partir de la entrega del producto al consumidor, mediante factura de compra. Si se produce algún cambio en la estructura del producto o se produce un defecto por negligencia del montador/consumidor en relación con las instrucciones de montaje y manipulación, no se prestará asistencia técnica gratuita.

#### NOTICE

To clean your furniture, use a dry or wet cloth, and do not use chemicals that may damage your product.

#### ASSEMBLY SYSTEM

The products' assembly system works according to the increasing order of the indicated numbers. For example: 01, 02, 03, 04 ... to the end of the assembly.

#### TECHNICAL ASSISTANCE

To request Technical Assistance, the consumer must contact the retailer from whom you purchased this product and request technical assistance for the damaged parts. The warranty covers all parts, parts and components that may eventually present a manufacturing defect within a period of 03 (three) months, counting from the delivery of the product to the consumer, by means of a purchase invoice. If there is any change in the structure of the product or defect occurs due to negligence of the assembler/consumer in relation to the assembly and handling instruction, free technical assistance will not be provided.

1º

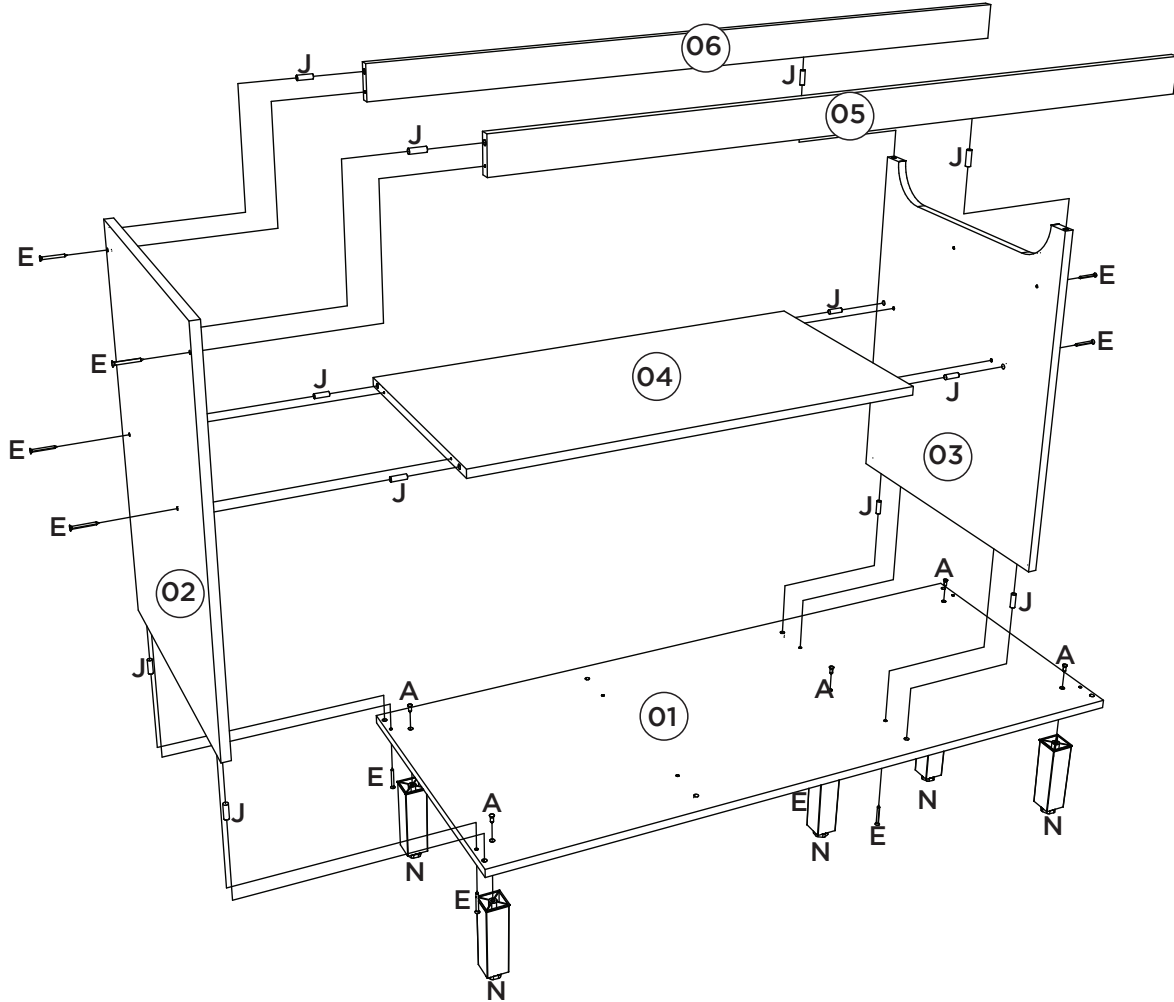

2º

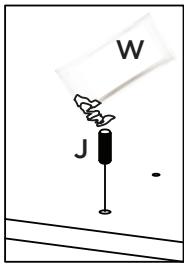

Utilizar o sachê de cola (W) em todas as cavilhas (J) do produto.

Con el pegamento sobre (W) en todos los pernos (J) producto.

Use the glue sachet (W) on all the pegs (J) of the product.

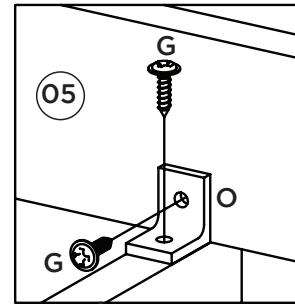

A pilastra da porta (08) deve estar alinhada com a divisão (03).

El pilar de la puerta (08) debe estar alineada con la división (03).

The door pillar (08) must be aligned with the partition (03).

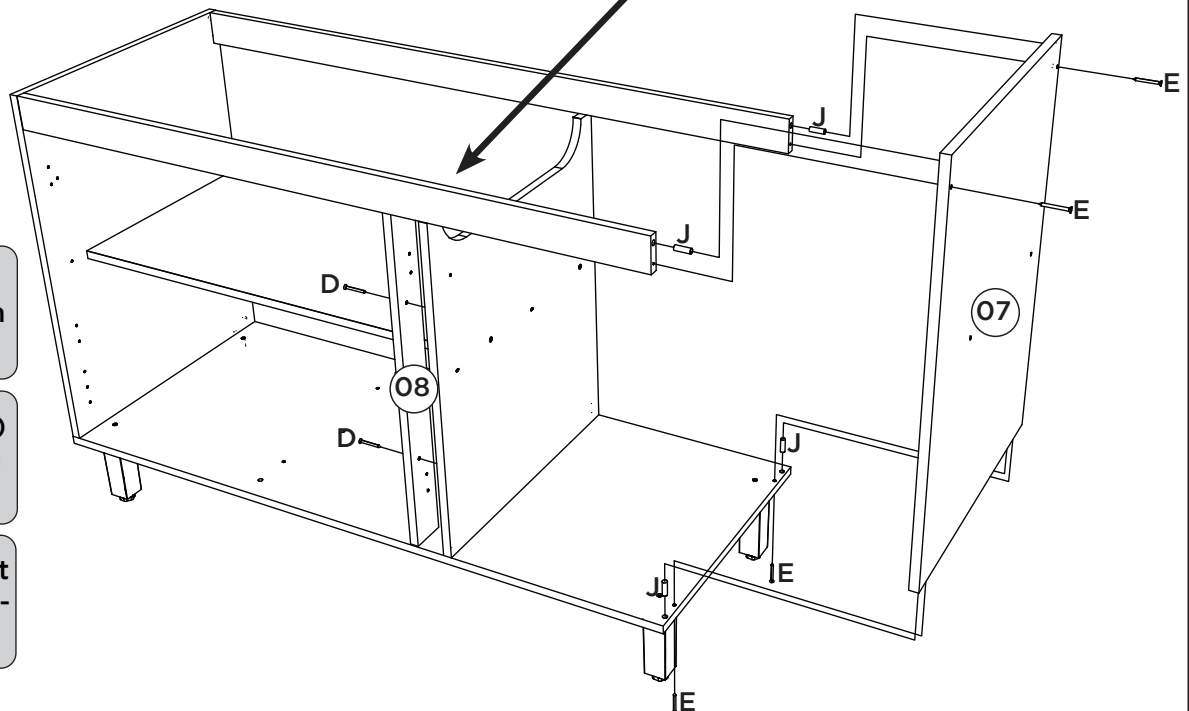

3º

Esse tampo é opcional e é vendido separadamente (C905-33).

Esta vez es opcional y se vende por separado (C905-33).

This top is optional and is sold separately (C905-33).

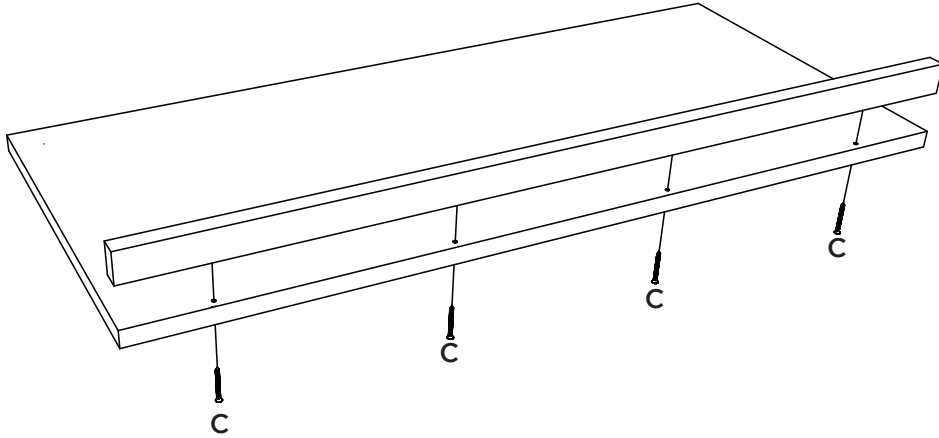

4º

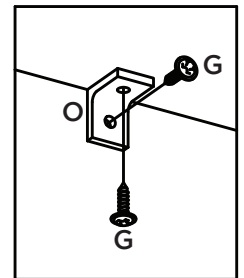
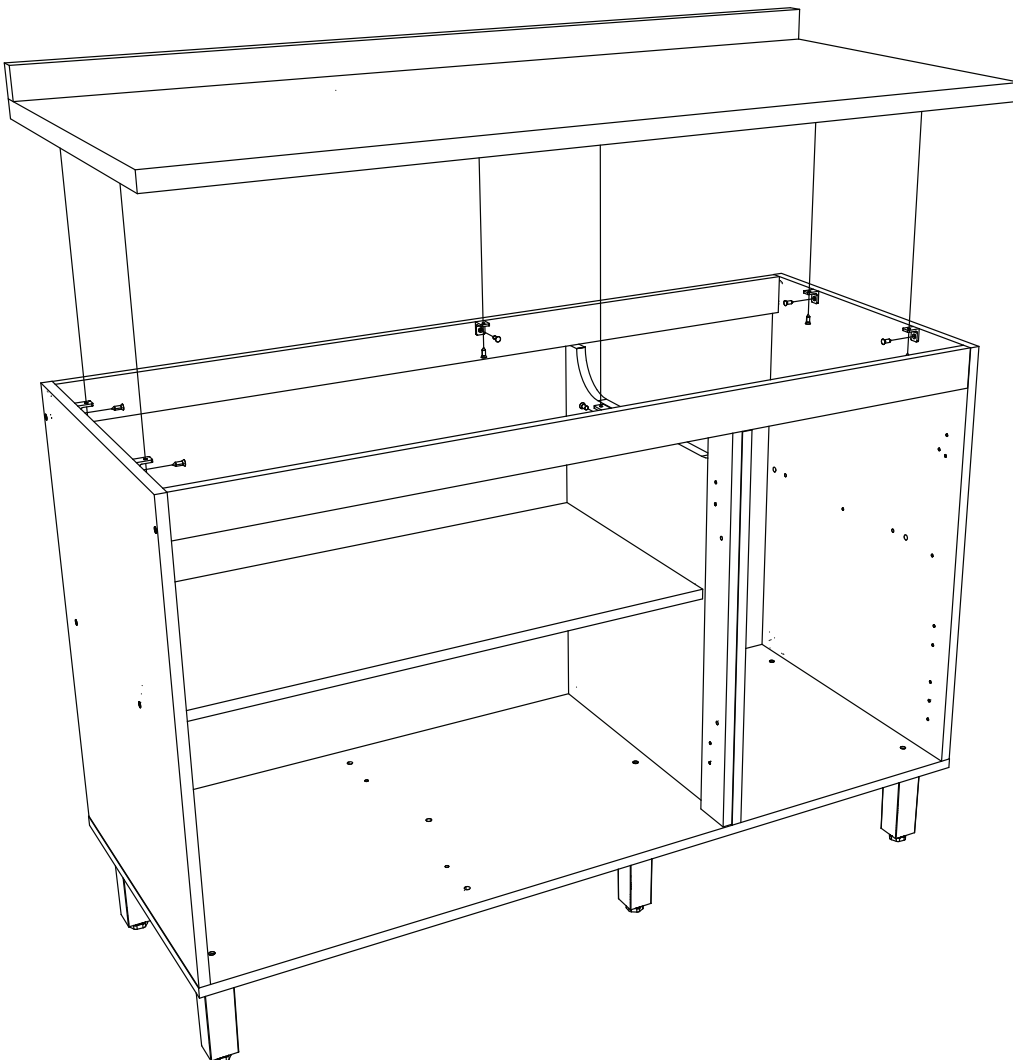

Caso o móvel seja montado com a opção do tampo, fixar o mesmo com 06 cantoneiras (O) e os parafusos 3,5x14mm (G).

Si se monta el auricular con la opción de la cubierta, fijarlo con Los ángulos 06 (O) y 3,5 x14mm tornillos (G).

If the furniture is to be installed with the top cover option, fix it with 06 (O) and 3.5x14mm screws (G).

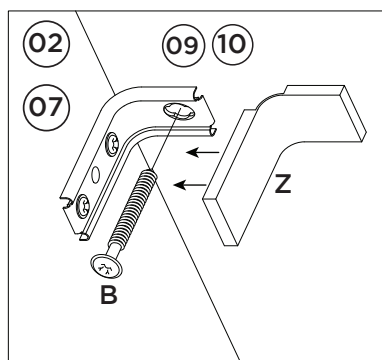
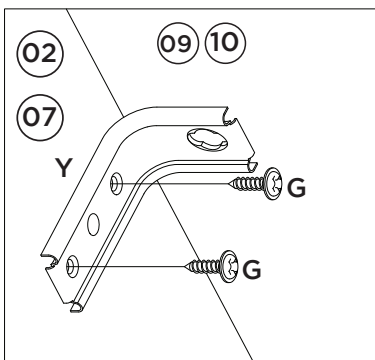
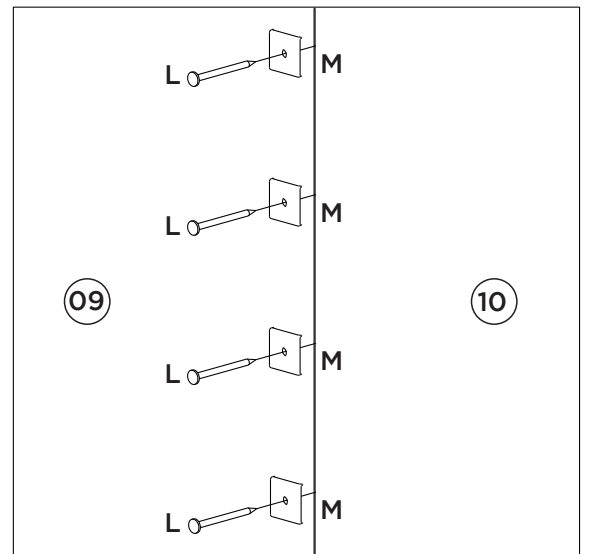
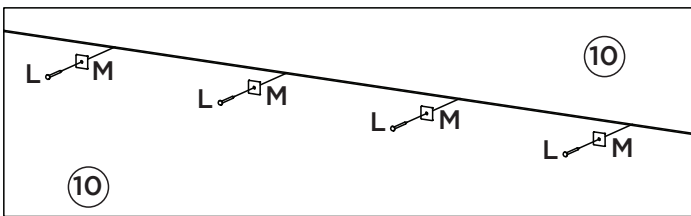
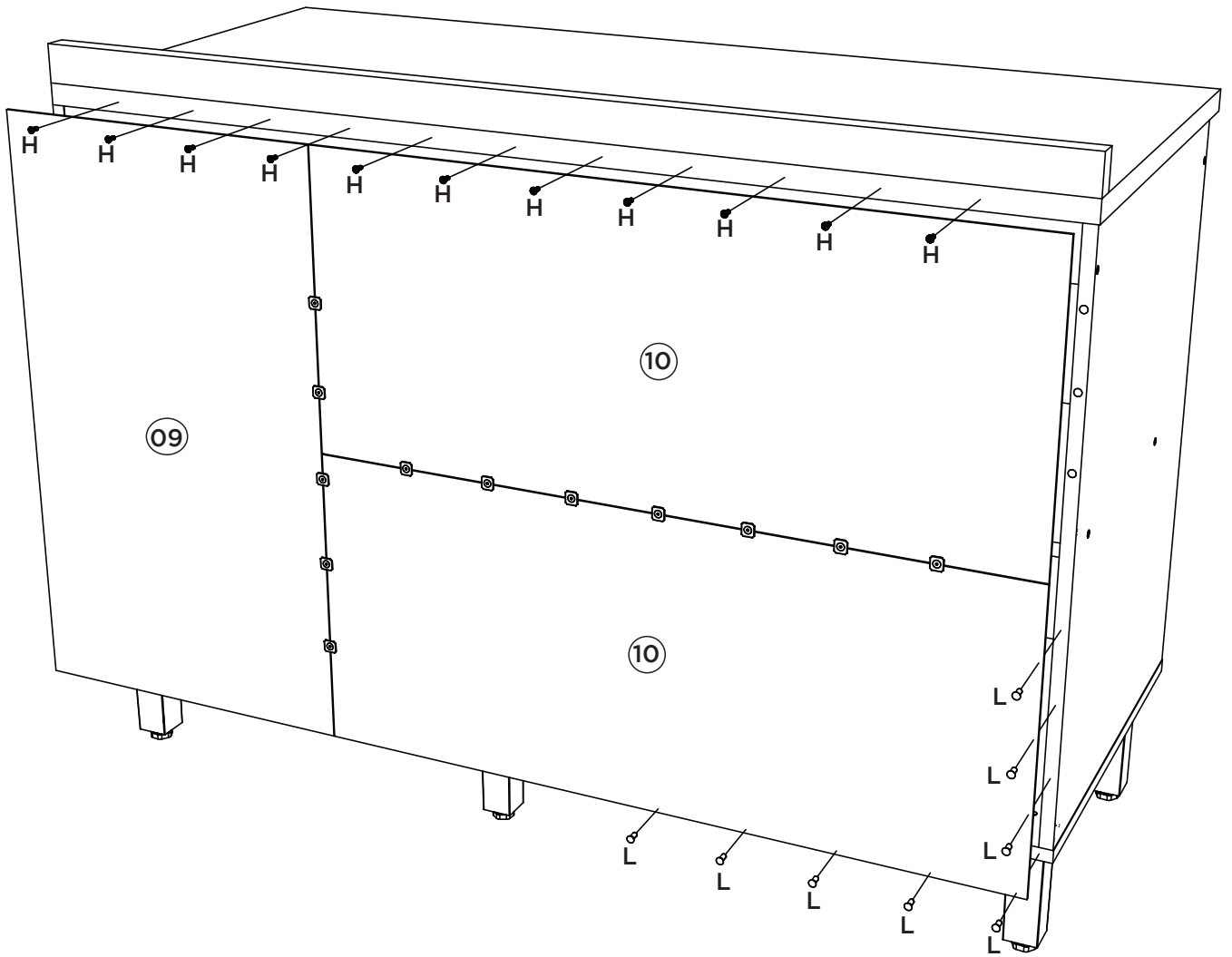

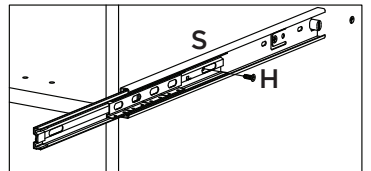
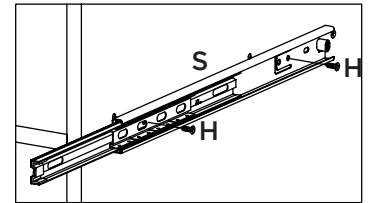
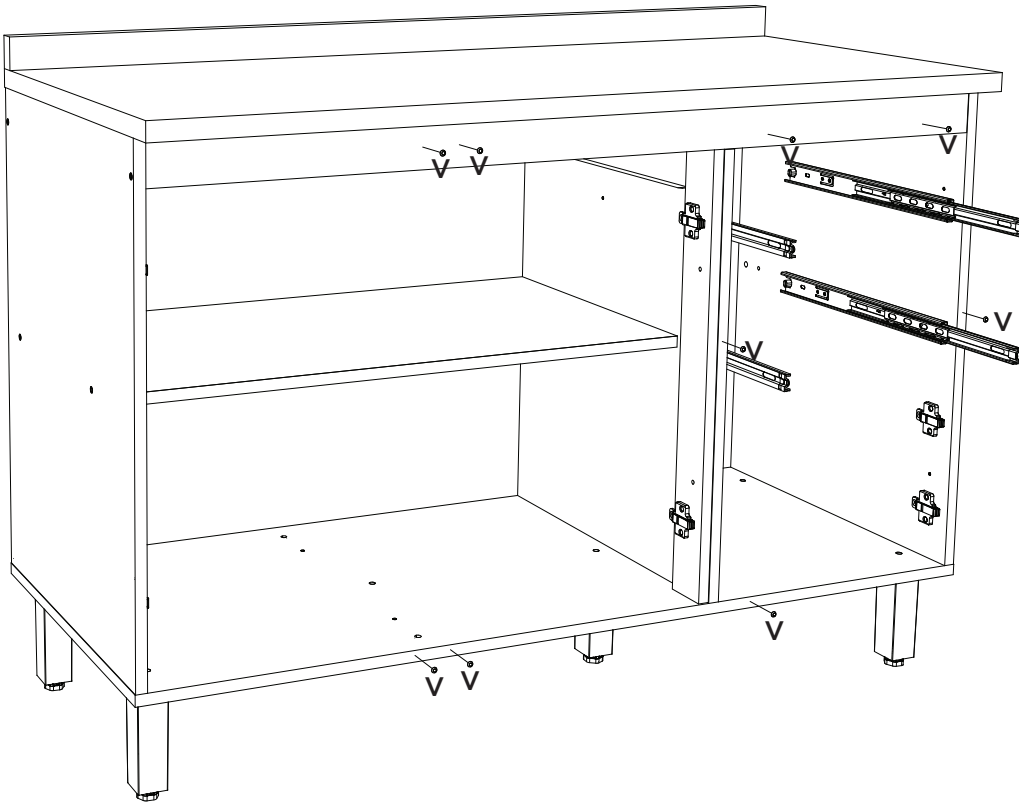

Fixação da corrediça telescópica (S).

Fijación Slide telescópico (S).

Fixing of the telescopic slide (S).

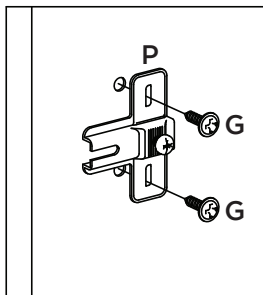

Fixação do calço 5mm (P).

Montaje de la placa de 5mm (P).

Shim fixation 5mm (P).

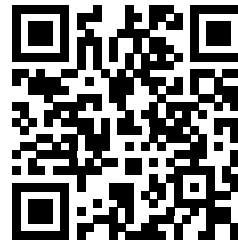

Vídeo: Dicas para fixar a Corrediça

Video: Consejos para arreglar la diapositiva

Video: Tips for Fixing the Slide

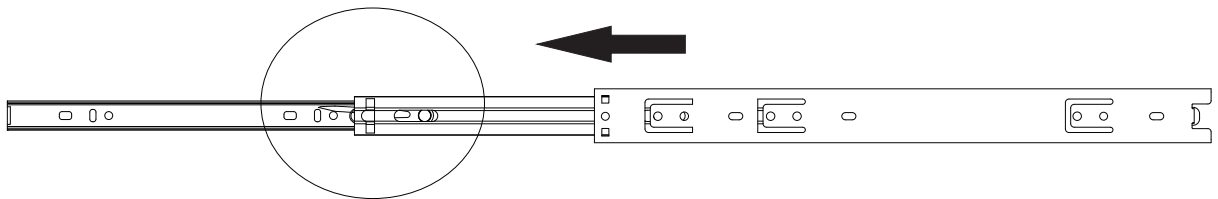

Para a desmontagem da corrediça siga a instrução ao lado.

Para el desmontaje seguimiento de diapositivas la instrucción siguiente a.

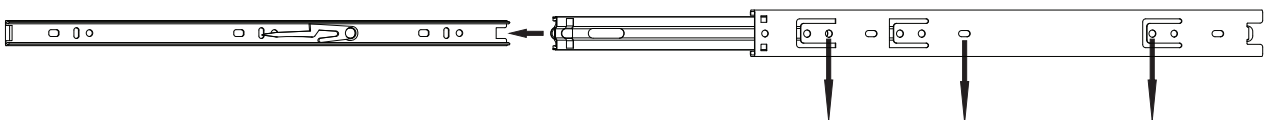
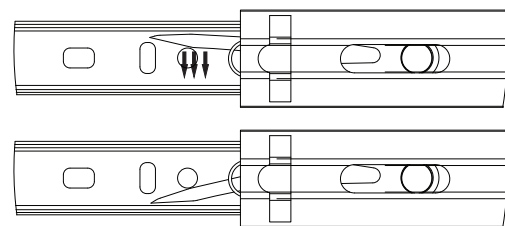

Fixar as corrediças nessas furações

Fijar las diapositivas de estos agujeros



Vídeo: Instalar e regular Dobradiças

Vídeo: Instale y ajuste las bisagras

Vídeo: Install and adjust hinges

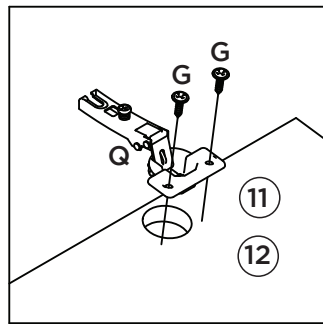

Fixação da dobradiça (Q).

La fijación de la bisagra (Q).

Hinge fixing (Q).

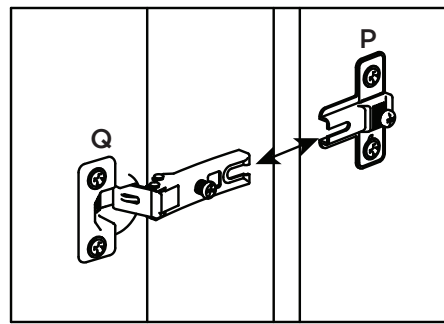

Encaixe da dobradiça (Q) com o calço (P).

Fije la bisagra (Q) con cuña (P).

Hinge fitting (Q) with shim (P).

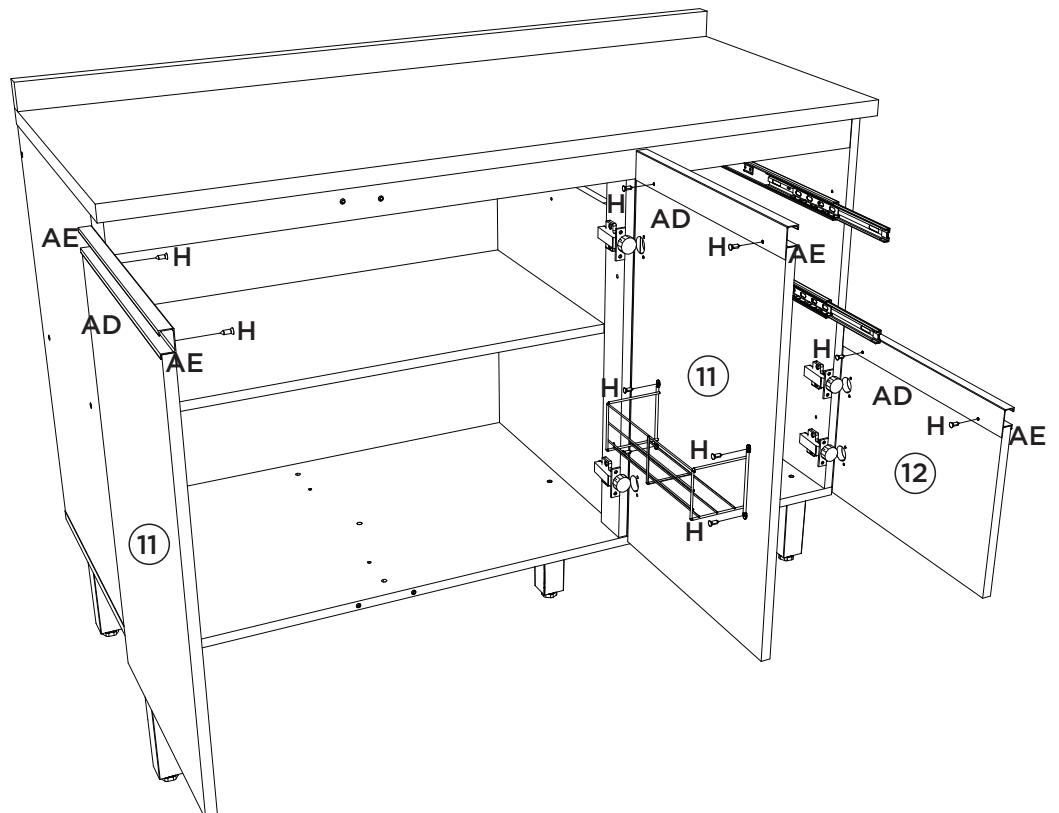
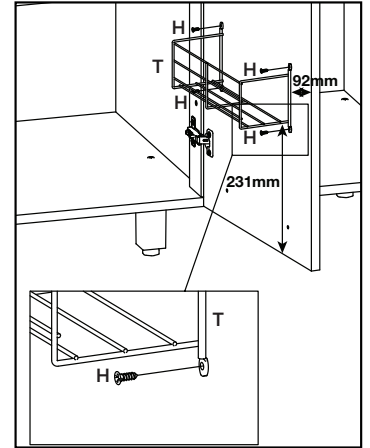
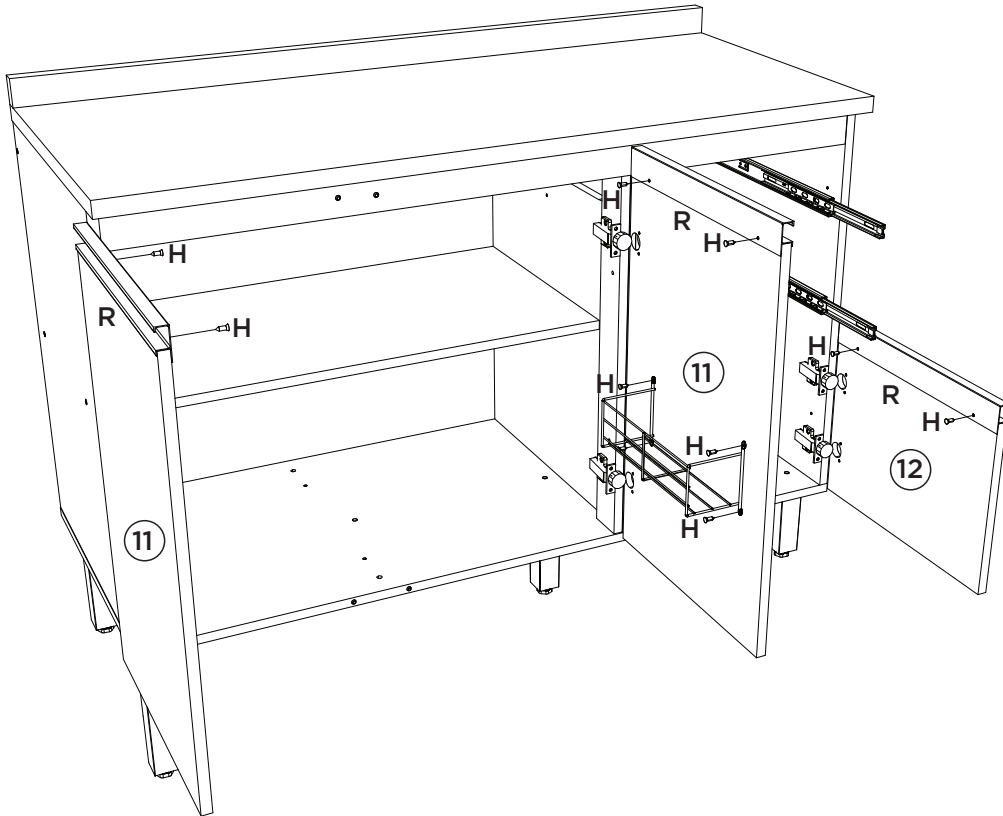

Somente para (C66-139)

Solo para (C66-139)

Only for (C66-139)

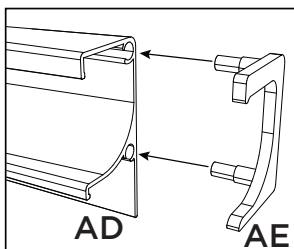

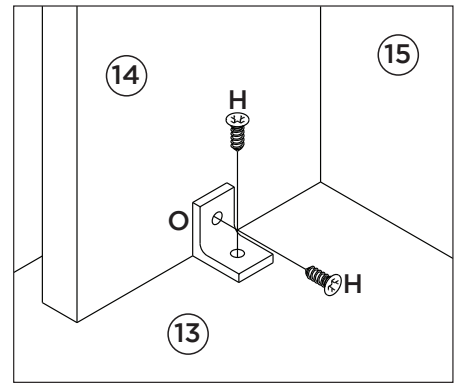
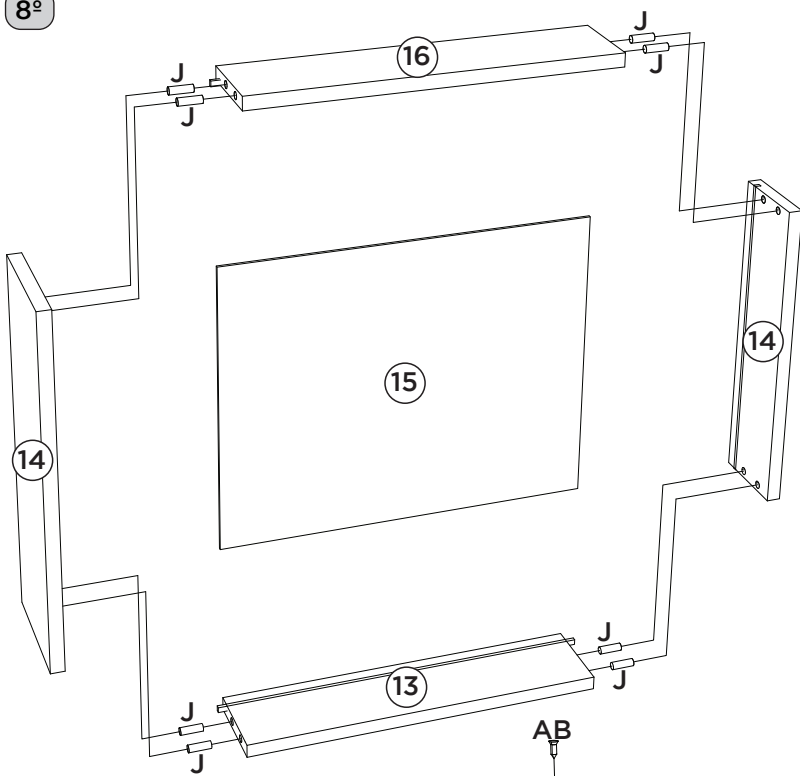

Somente para (C66-139)

Solo para (C66-139)

Only for (C66-139)

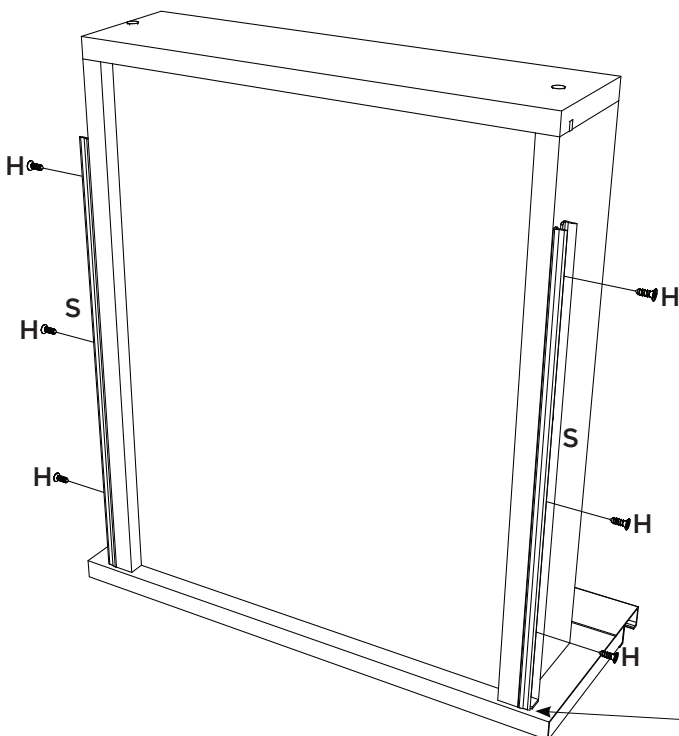
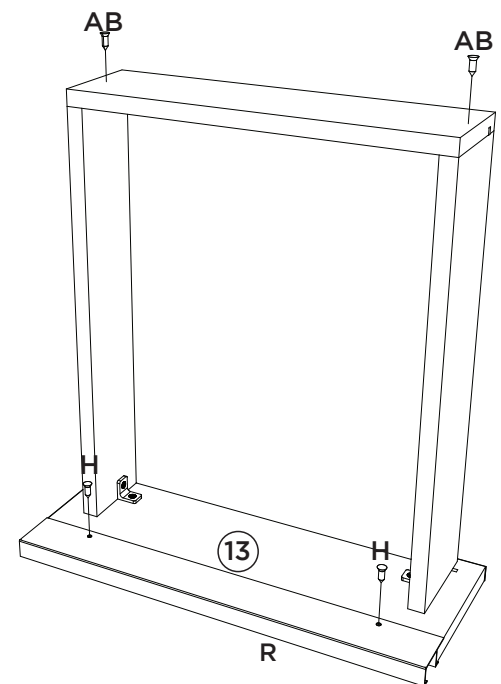
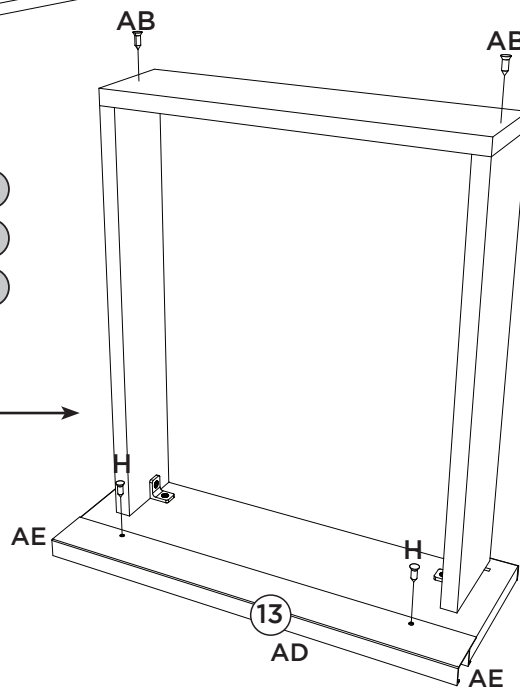
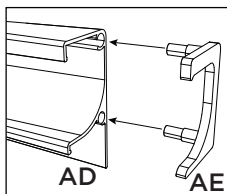

A corredeira (S) deverá ser alinhada com a parte de baixo do lado de gaveta (14).

La carcasa (S) será alineada con la parte de por el lado del cajón (14).

The slide (S) should be aligned with the underside of the drawer side (14).

Deixar 3mm de distância da frente de gaveta.











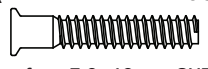
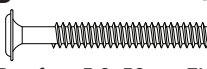

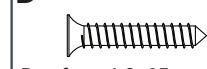
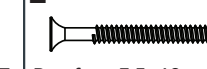





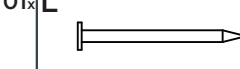
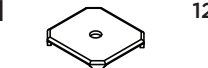
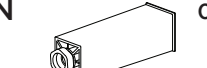



Deje una separación de 3mm del frente del cajón.

Leave 3mm away from the front of the drawer.

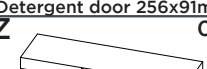
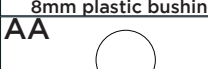
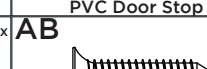

Item	Caixa Caja Box	Qty Ctd Qty	Descrição   Descripción   Description	Medidas (mm)   Dimensions (mm)   Size (measurements) (mm)
01	1/1	01	Base   Base   Base	1200x490x15
02	1/1	01	Lateral esquerda   Lateral izquierda   Left side	660x490x15
03	1/1	01	Divisão   División   Division	600x490x15
04	1/1	01	Prateleira   Estante   Shelf	783x400x15
05	1/1	01	Travessa frontal   Travesaño frontal   Front crossbar	1168x60x15
06	1/1	01	Travessa traseira   Travesaño trasero   Rear bumper	1168x60x15
07	1/1	01	Lateral direita   Lateral derecha   Right side	660x490x15
08	1/1	01	Pilastra da Porta   Pilastra Puerta   Pilaster door	599x60x15
09	1/1	01	Fundo menor   Fondo menor   Minor fund	683x389x3
10	1/1	02	Fundo   Fondo   Bottom	802x341x3
11	1/1	02	Porta   Puerta   Door	625x396x15
11	1/1	02	Porta   Puerta   Door (Somente para C66-139)	629x396x15
12	1/1	01	Porta menor   Puerta menor   Smaller door	396x290x15
12	1/1	01	Porta menor   Puerta menor   Smaller door (Somente para C66-139)	396x294x15
13	1/1	02	Frente de gaveta   Frente de cajón   Front of drawer	396x136x15
13	1/1	02	Frente de gaveta   Frente de cajón   Front of drawe (Somente pra C66-139)	396x140x15
14	1/1	04	Lado de Gaveta menor   Lado del cajón menor   Smallest Drawer Side	400x90x15
15	1/1	02	Fundo de gaveta   Fondo de cajón   Bottom of drawer	411x326x3
16	1/1	02	Ripa de trás   Malla detrás   Rear lath	345x90x15

Ferragens | Herrajes | Hardware

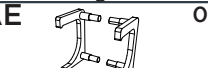
<b>A</b>  Parafuso 7,0x40mm CHT. Tornillo 7,0x40mm CHT. Screw 7,0x40mm CHT.	<b>B</b>  Parafuso 5,0x50mm FLA. Tornillo 5,0x50mm FLA. Screw 5,0x50mm FLA.	<b>C</b>  Parafuso 4,5x50mm CHT. Tornillo 4,5x50mm CHT. Screw 4,5x50mm CHT.	<b>D</b>  Parafuso 4,0x25mm CHT. Tornillo 4,0x25mm CHT. Screw 4,0x25mm CHT.	<b>E</b>  Parafuso 3,5x40mm CHT. Tornillo 3,5x40mm CHT. Screw 3,5x40mm CHT.	<b>F</b>  Divisor talheres 398x313mm Divisor cubiertos 398x313mm Cutlery divider 398x313mm
<b>G</b>  Parafuso 3,5x14mm FLA. Tornillo 3,5x14mm FLA. Screw 3,5x14mm FLA.	<b>H</b>  Parafuso 3,5x12mm CHT. Tornillo 3,5x12mm CHT. Screw 3,5x12mm CHT.	<b>I</b>  Giz de correção Tiza de corrección Chalk of correction	<b>J</b>  Cavilha 8x25mm Cinta 8x25mm Dowel 8x25mm	<b>K</b>  Etiqueta resinada Henn Etiqueta resinada Henn Henn resin label	<b>L</b>  Prego 10x10mm Clavo 10x10mm Nail 10x10mm
<b>M</b>  Fixador de fundos Fijador de fondos Bottom fixer	<b>N</b>  Pé 145mm x 42mm Pie 145mm x 42mm Foot 145mm x 42mm	<b>O</b>  Cantoneira plástica Cantонера plástica Plastic angle brackets	<b>P</b>  Calço metal médio 0mm Calzado metálico medio 0mm Metal shim 0mm	<b>Q</b>  Dobradiça metal Baixa 35mm Bisagra metálica Baja 35mm Metal hinge Low 35mm	<b>R</b>  Puxador MOV 396mm Tirador MOV 396mm MOV 396mm Handle
<b>S</b>  Corrediza telescópica Diapositivas telescópicas Telescopic slides	<b>T</b>  Porta detergente 256x91mm Puerta detergente 256x91mm Detergent door 256x91mm	<b>U</b>  Bucha plástica 8mm Bucha de plástico 8mm 8mm plastic bushing	<b>V</b>  Batente PVC para Porta Parada de PVC para Puerta PVC Door Stop	<b>W</b>  Sachê de cola Bolsa de pegamento Glue bag	<b>X</b>  Adesivo tapa parafuso 17mm Adhesivo tapón de tornillo 17mm Bolt cover adhesive 17mm
<b>Y</b>  Suporte de fixação Soporte de fijación Mounting bracket	<b>Z</b>  Proteção para cantoneira Ángulo de protección Protection angle	<b>AA</b>  Adesivo tapa parafuso 10mm Adhesivo tapón de tornillo 10mm Bolt cover adhesive 10mm	<b>AB</b>  Parafuso 3,0x30mm CHT. Tornillo 3,0x30mm CHT. Screw 3,0x30mm CHT.	<b>AC</b>  Parafuso União 30mm Tornillo Unión 30mm Union Screw 30mm	<b>AD</b>  Puxador MOV4083 - 392mm Tirador MOV4083 - 392mm MOV4083 - 392mm Handle
<b>AE</b>  Kit Ponteira Plástica MOV4083 Kit de punta de plástico MOV4083 Plastic Tip Kit MOV4083					

Somente para (C66-139)

Solo para (C66-139)

Only for (C66-139)



O parafuso (AC) deve ser usada somente quando este módulo for acoplado a outro módulo componível Henn.

RECOMENDAÇÃO

Para fixar o móvel na parede usar o suporte de fixação (Y), o parafuso 3,5x14mm FLA (G), a Bucha 8mm (U) e o parafuso 5,0x50mm FLA (B).



El tornillo (AC) se debe utilizar sólo cuando el módulo está conectado a otro módulo componible Henn.

RECOMENDACIÓN

Para conectar el móvil a la pared con el soporte (Y), tornillo 3,5 x14mm FLA (G), el casquillo de 8 mm (U) y el 5,0 x50mm tornillo FLA (B).



The screw (AC) should be used only when this module is attached to another Henn modular module.

RECOMMENDATION

To fix the furniture to the wall use the mounting bracket (Y), the 3.5x14mm FLA (G) screw, the 8mm bushing (U) and the 5.0x50mm FLA (B).



**HENN**Ind. e Com. de Móveis Henn  
Mondai - SC - Brasil

☎ +55 49 3674.3500

 @moveishenn  
www.henn.com.br
**INSTRUÇÕES DE MONTAGEM****INSTRUCCIONES DE MONTAJE**  
**ASSEMBLY INSTRUCTIONS****Torre Quente 1 Forno 715mm Connect | Torre caliente 1 Horno 715mm Connect |**  
**Hot Tower 1 Oven 715mm Connect****Referência/Cor**

c C70-35 - Duna/Cristal  
c C70-42 - Fendi  
c C70-139 - Off White

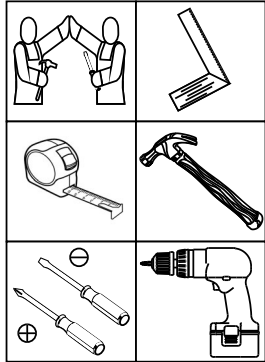
**Requisitos para montagem**  
**Requisitos para la montaje**  
**Assembly Requirements**

Imagens meramente ilustrativas  
Imágenes meramente ilustrativas  
Images for illustration only

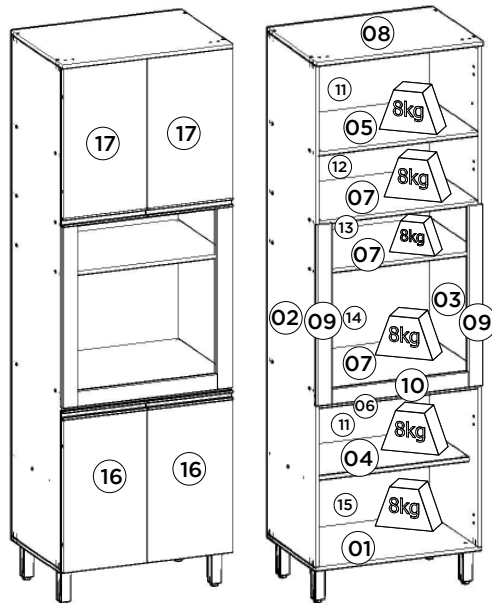

Pesos máximos recomendados com carga distribuída  
Peso máximo recomendado con la carga distribuída  
Recommended maximum weight with distributed load.

**Lista de Peças | Lista de piezas | List of parts**

Item	Caixa Caja Box	Qtd Ctd Qty	Descrição   Descripción   Description	Medidas (mm)   Dimensiones (mm)   Size (measurements) (mm)
01	1/2	01	Base   Base   Base	715x490x15
02	1/2	01	Lateral esquerda   Lateral izquierda   Left side	2030x490x15
03	1/2	01	Lateral direita   Lateral derecha   Right side	2030x490x15
04	1/2	01	Prateleira Inferior   Estante Inferior   Bottom Shelf	683x400x15
05	1/2	01	Prateleira   Estante   Shelf	683x490x15
06	1/2	01	Travessa inferior frontal   Travesaño inferior frontal   Front lower crossbar	683x65x15
07	1/2	03	Prateleira maior   Estante mayor   Largest shelf	683x490x15
08	1/2	01	Tampo   Tapa   Top	715x505x15
09	1/2	02	Travessa lateral   Travesaño lateral   Lateral crossbar	727x60x15
10	1/2	01	Travessa frontal   Travesaño frontal   Front crossbar	589x60x15
11	1/2	02	Fundo   Fondo   Bottom	707x376x3
12	1/2	01	Fundo Superior   Fondo superior   Superior background	707x279x3
13	1/2	01	Fundo Estreito   Fondo Estrecho   Narrow Bottom	707x199x3
14	1/2	01	Fundo central   Fondo central   Central fund	707x479x3
15	1/2	01	Fundo inferior   Fondo inferior   Bottom background	707x341x3
16	2/2	02	Porta   Puerta   Door	625x354x15
16	2/2	02	Porta   Puerta   Door (Somnete para C70-139)	629x354x15
17	2/2	02	Porta Superior   Puerta superior   Superior door	612x354x15
17	2/2	02	Porta Superior   Puerta superior   Superior door (Somnete para C70-139)	616x354x15

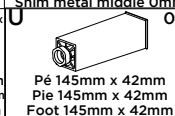

O parafuso (C) deve ser usada somente quando este módulo for acoplado a outro módulo componível Henn.

El tornillo (C) se debe utilizar sólo cuando el módulo está conectado a otro módulo componible Henn.

The screw (C) should be used only when this module is attached to another Henn modular module.

**RECOMENDAÇÃO**

Para fixar o móvel na parede usar o suporte de fixação (W), o parafuso 3,5x14mm FLA (F), a Bucha 8mm (P) e o parafuso 5,0x50mm FLA (B).

**RECOMENDACIÓN**

Para conectar el móvil a la pared con el soporte (W), tornillo 3,5 x14mm FLA (F), el casquillo de 8 mm (P) y el 5,0 x50mm tornillo FLA (B).

**RECOMMENDATION**

To fix the furniture to the wall use the fixing bracket (W), the 3.5x14mm FLA (F) screw, the 8mm bushing (P) and the 5.0x50mm FLA (B).

**AVISO**

Para limpeza de seu móvel, use uma flanela seca ou umedecida, e não utilize produtos químicos que possam danificar seu produto.

**SISTEMA DE MONTAGEM**

O sistema de montagem dos produtos, funciona de acordo com a ordem crescente dos números indicados no desenho. Ex: 01, 02, 03, 04... até a conclusão da montagem.

**ASISTENCIA TÉCNICA**

Para solicitação de Assistência Técnica você consumidor deverá entrar em contato com o Lojista a qual você realizou a compra deste produto e solicitar a assistência técnica das peças avariadas. A garantia abrange todas as peças, partes e componentes que eventualmente venham apresentar defeito de fabricação no prazo de 03 (três) meses, contando a partir da entrega do produto ao consumidor, mediante nota fiscal de compra. Se houver qualquer alteração na estrutura do produto ou ocorrer defeito por negligência do montador/consumidor em relação a instrução de montagem e manuseio, não será fornecido assistência técnica gratuita.

**ADVERTENCIA**

Para limpeza de su móvil, use una flanela seca o húmeda, y no utilice productos químicos que puedan dañar su producto.

**SISTEMA DE MONTAJE**

El sistema de montaje de los productos funciona de acuerdo con el orden creciente de los números indicados en el dibujo. Ej.: 01, 02, 03, 04... hasta la conclusión del montaje.

**ASISTENCIA TÉCNICA**

Para solicitar Asistencia Técnica, el consumidor debe comunicarse con el Comercio que usted realizó la compra de este producto y solicita asistencia técnica para las partes dañadas. La garantía cubre todas las partes, piezas y componentes que eventualmente puedan presentar defecto de fabricación en el plazo de 03 (tres) meses, contados a partir de la entrega del producto al consumidor, mediante factura de compra. Si se produce algún cambio en la estructura del producto o se produce un defecto por negligencia del montador/consumidor en relación con las instrucciones de montaje y manipulación, no se prestará asistencia técnica gratuita.

**NOTICE**

To clean your furniture, use a dry or wet cloth, and do not use chemicals that may damage your product.

**ASSEMBLY SYSTEM**

The products' assembly system works according to the increasing order of the indicated numbers. For example: 01, 02, 03, 04 ... to the end of the assembly.

**TECHNICAL ASSISTANCE**

To request Technical Assistance, the consumer must contact the retailer from whom you purchased this product and request technical assistance for the damaged parts. The warranty covers all parts, parts and components that may eventually present a manufacturing defect within a period of 03 (three) months, counting from the delivery of the product to the consumer, by means of a purchase invoice. If there is any change in the structure of the product or defect occurs due to negligence of the assembler/consumer in relation to the assembly and handling instruction, free technical assistance will not be provided.

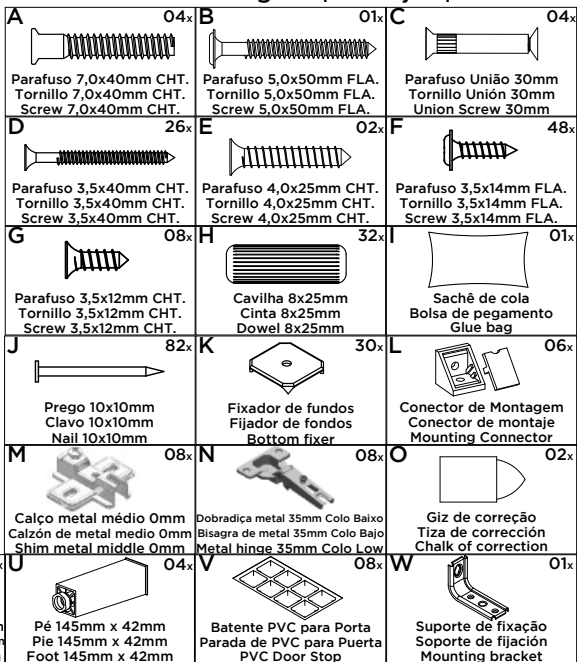
**Ferragens | Herrajes | Hardware**

Proteção para cantoneira  
 Ángulo de protección  
 Protection angle

Somente para (C70-139)  
 Solo para (C70-139)  
 Only for (C70-139)

1º

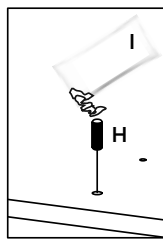
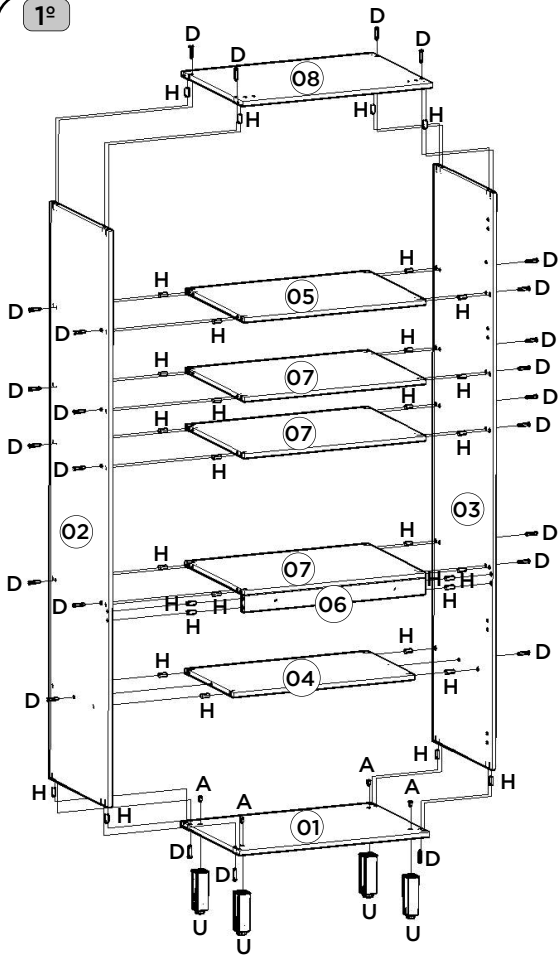

Utilizar o sachê de cola (I) em todas as cavilhas (H) do produto.

Con el pegamento sobre (I) en todos los pernos (H) producto.

Use the glue sachet (I) on all the pegs (H) of the product.

2º

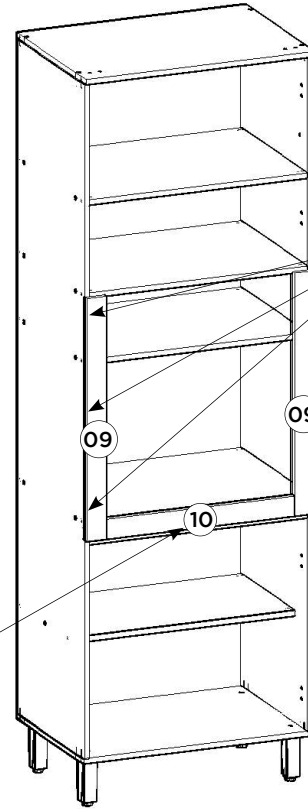
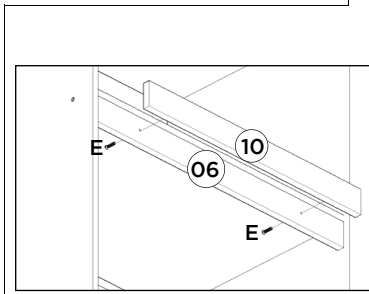

Conector de Montagem fixado internamente

Conector de montaje fijado internamente

Mounting Connector fixed internally

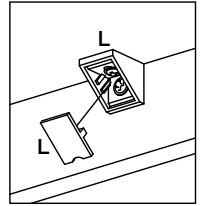
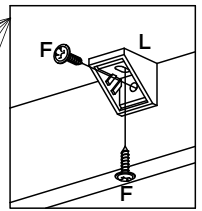

3º

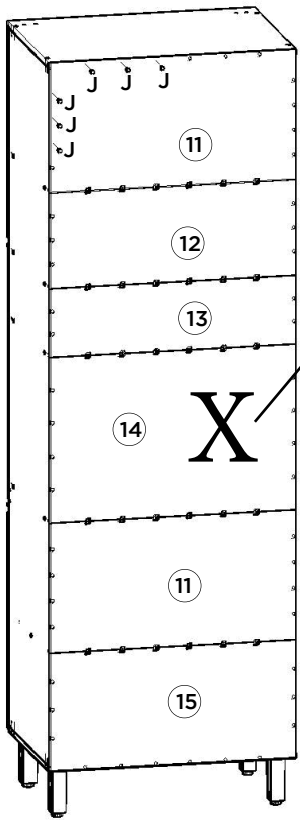

**ATENÇÃO:** Por questão de segurança, recomendamos a não utilização do Fundo (14) caso o espaço seja utilizado por forno elétrico ou forno embutido, dessa forma, haverá melhor propagação do calor, evitando danos em seu móvel.

**ADVERTENCIA:** Por razones de seguridad, se recomienda no utilizar el Fondo (14) si el espacio es utilizado por horno eléctrico o una función de horno, de esta manera no será mejor propagación del calor, evitando el daño a su móvil.

**ATTENTION:** For safety reasons, we recommend not using the Fund (14) if the space is used by an electric oven or built-in oven, in this way, there will be better propagation of the heat, avoiding damage to your furniture.

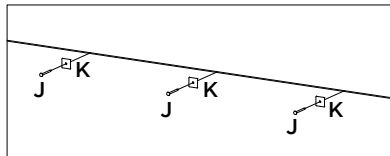

4º

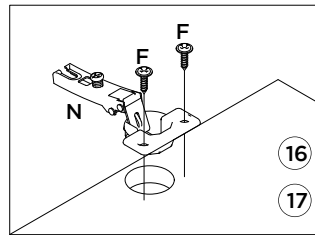
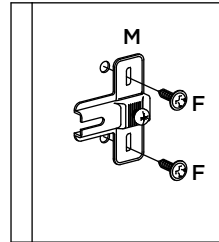

Somente para (C70-139)

Solo para (C70-139)

Only for (C70-139)

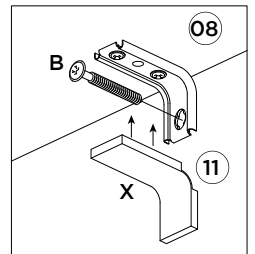
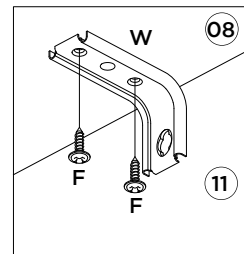
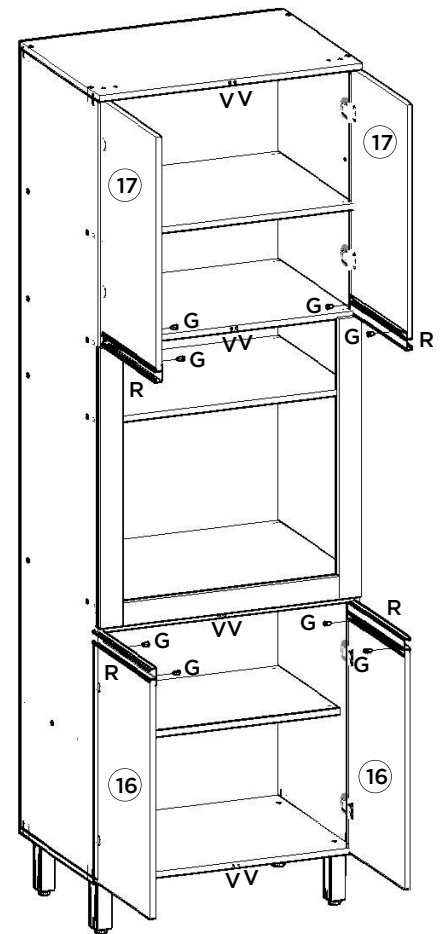
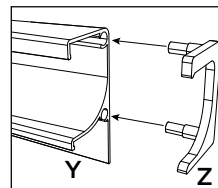

Video: Instalar e regular Dobradiças

Video: Instale y ajuste las bisagras

Video: Install and adjust hinges

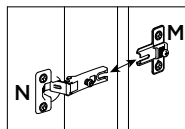

**HENN**Ind. e Com. de Móveis Henn  
Mondai - SC - Brasil

☎+55 49 3674.3500

📧@moveishenn  
www.henn.com.br**INSTRUÇÕES DE MONTAGEM**INSTRUCCIONES DE MONTAJE  
ASSEMBLY INSTRUCTIONS**Tampo Cooktop 800mm | Tampo Cooktop 800mm | Cooktop top 800mm**

- C908-23 Duna
- C908-33 Nero
- C908-114 Calcare

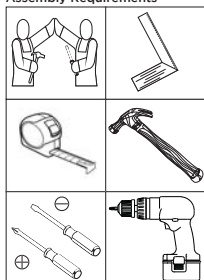
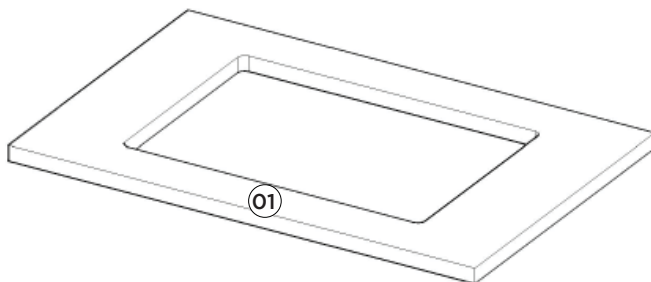
Requisitos para montagem  
Requisitor para la montaje  
Assembly RequirementsImagens meramente ilustrativas  
Imágenes meramente ilustrativas  
Images for illustration only**AVISO**

Para limpeza de seu móvel, use uma flanela seca ou umedecida, e não utilize produtos químicos que possam danificar seu produto.

**SISTEMA DE MONTAGEM**

O sistema de montagem dos produtos, funciona de acordo com a ordem crescente dos números indicados no desenho. Ex: 01, 02, 03, 04... até a conclusão da montagem.

**ADVERTENCIA**

Para limpieza de su móvil, use una franela seca o húmeda, y no utilice productos químicos que puedan dañar su producto.

**Lista de Peças | Lista de piezas | List of parts**

Item	Caixa Caja Box	Qty Ctd Qty	Descrição   Descripción   Description	Medidas (mm)   Dimensions (mm)   Size (measure- ments) (mm)
01	1/1	01	Tampo   Tapa   Top	800x533x25

**SISTEMA DE MONTAJE**

El sistema de montaje de los productos funciona de acuerdo con el orden creciente de los números indicados en el dibujo. Ej.: 01, 02, 03, 04... hasta la conclusión del montaje.



**NOTICE**

To clean your furniture, use a dry or wet cloth, and do not use chemicals that may damage your product.

**ASSEMBLY SYSTEM**

The products' assembly system works according to the increasing order of the indicated numbers. For example: 01, 02, 03, 04 ... to the end of the assembly.

**Ferragens | Herrajes | Hardware**

<b>A</b>		08x	<b>B</b>		04x
Parafuso 3,5x14mm FLA. Tornillo 3,5x14mm FLA. Screw 3,5x14mm FLA.			Cantoneira plástica Cantонера plástica Plastic angle brackets		



Estas ferragens constam no Pacote do respectivo Balcão.  
Estos herrajes constan en el Paquete del respectivo Balcón.  
These hardware are included in the Package of the respective Counter.

Esse tampo é opcional e é vendido separadamente

Esta vez es opcional y se vende por separado

This top is optional and is sold separately

Exemplo de como fixar o Tampo Cooktop no produto.

Ejemplo de cómo fijar el Tablero Cooktop en el producto.

Example of how to secure the Cooktop Top to the product.

