

HENN

Ind. e Com. de Móveis Henn
Mondai - SC - Brasil

+55 49 3674.3500

@moveishenn
www.henn.com.br

INSTRUÇÕES DE MONTAGEM

INSTRUCCIONES DE MONTAJE
ASSEMBLY INSTRUCTIONS

Cozinha Completa 6 Peças com Torre 2 Fornos com Tampo Aurora

☐ CE734-35 - Duna/Cristal

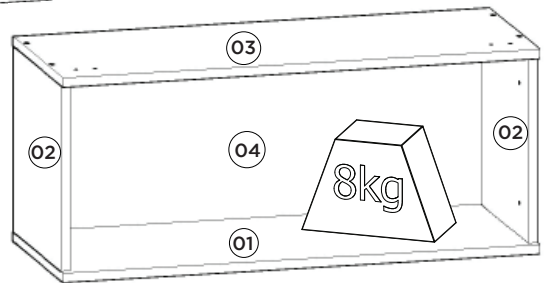
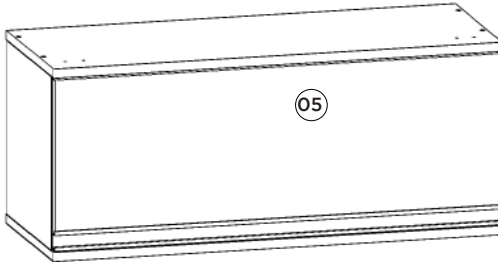

Pesos máximos recomendados
com carga distribuída
Peso máximo recomendado com
a carga distribuída
Recommended maximum weight
with distributed load.

Requisitos para montagem
Requisitos para la montaje
Assembly Requirements

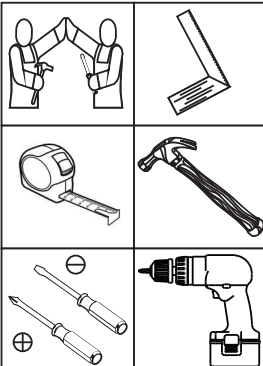

Imagens meramente ilustrativas
Imágenes meramente ilustrativas
Images for illustration only

AVISO

Para limpeza de seu móvel, use uma flanela seca ou umedecida, e não utilize produtos químicos que possam danificar seu produto.

SISTEMA DE MONTAGEM

O sistema de montagem dos produtos, funciona de acordo com a ordem crescente dos números indicados no desenho. Ex: 01, 02, 03, 04... até a conclusão da montagem.

ASSISTÊNCIA TÉCNICA

Para solicitação de Assistência Técnica você consumidor deverá entrar em contato com o Lojista o qual você realizou a compra deste produto e solicitar a assistência técnica das peças avariadas. A garantia abrange todas as peças, partes e componentes que eventualmente venham apresentar defeito de fabricação no prazo de 03 (três) meses, contando a partir da entrega do produto ao consumidor, mediante nota fiscal de compra. Se houver qualquer alteração na estrutura do produto ou ocorrer defeito por negligência do montador/consumidor em relação a instrução de montagem e manuseio, não será fornecido assistência técnica gratuita.

ADVERTENCIA

Para limpieza de su móvil, use una flanela seca o húmeda, y no utilice productos químicos que puedan dañar su producto.

SISTEMA DE MONTAJE

El sistema de montaje de los productos funciona de acuerdo con el orden creciente de los números indicados en el dibujo. Ej.: 01, 02, 03, 04... hasta la conclusión del montaje.

ASISTENCIA TÉCNICA

Para solicitar Asistencia Técnica, el consumidor debe comunicarse con el Comercio que usted realizó la compra de este producto y solicita asistencia técnica para las partes dañadas. La garantía cubre todas las partes, piezas y componentes que eventualmente puedan presentar defecto de fabricación en el plazo de 03 (tres) meses, contados a partir de la entrega del producto al consumidor, mediante factura de compra. Si se produce algún cambio en la estructura del producto o se produce un defecto por negligencia del montador/consumidor en relación con las instrucciones de montaje y manipulación, no se prestará asistencia técnica gratuita.

NOTICE

To clean your furniture, use a dry or wet cloth, and do not use chemicals that may damage your product.

ASSEMBLY SYSTEM

The products' assembly system works according to the increasing order of the indicated numbers. For example: 01, 02, 03, 04 ... to the end of the assembly.

TECHNICAL ASSISTANCE

To request Technical Assistance, the consumer must contact the retailer from whom you purchased this product and request technical assistance for the damaged parts. The warranty covers all parts, parts and components that may eventually present a manufacturing defect within a period of 03 (three) months, counting from the delivery of the product to the consumer, by means of a purchase invoice. If there is any change in the structure of the product or defect occurs due to negligence of the assembler/consumer in relation to the assembly and handling instruction, free technical assistance will not be provided.

1º

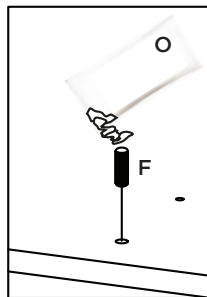
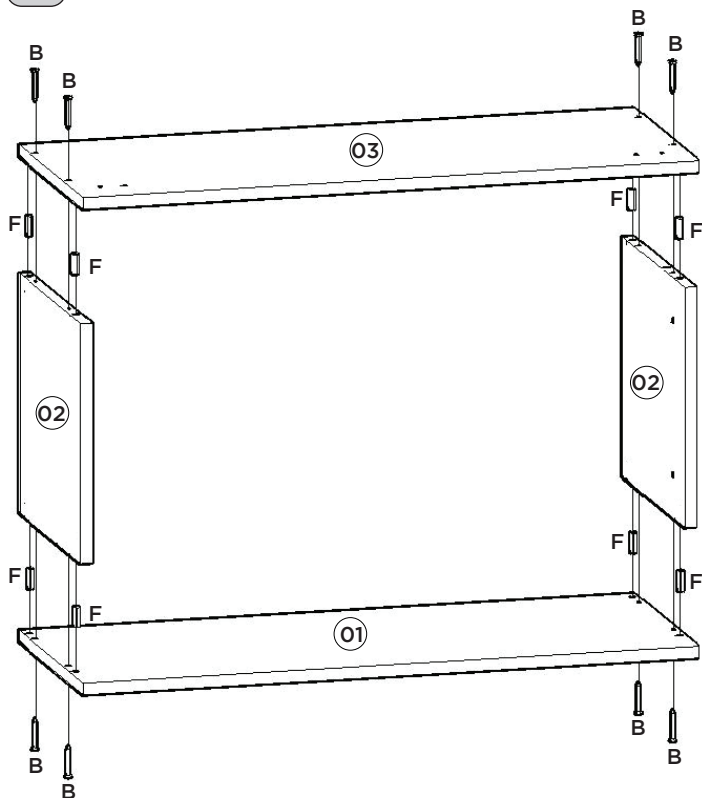

Utilizar o sachê de cola (O) em todas as cavilhas (F) do produto.

Con el pegamento sobre (O) en todos los pernos (F) producto.

Use the glue sachet (O) on all the pegs (F) of the product.

2º

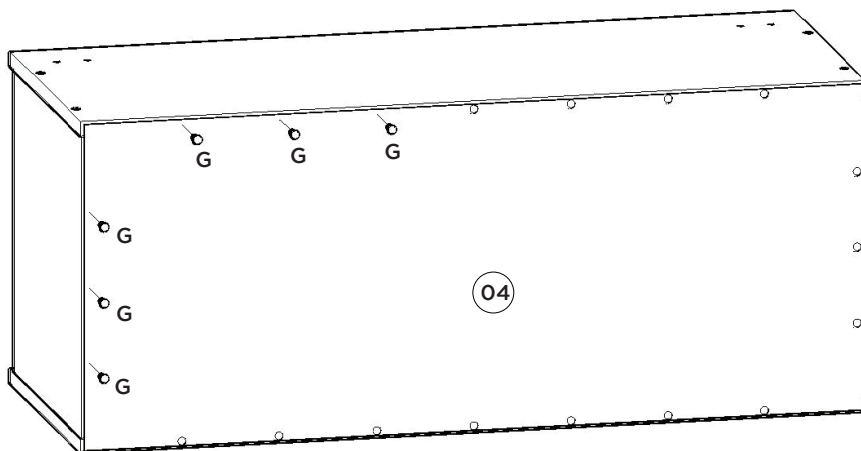

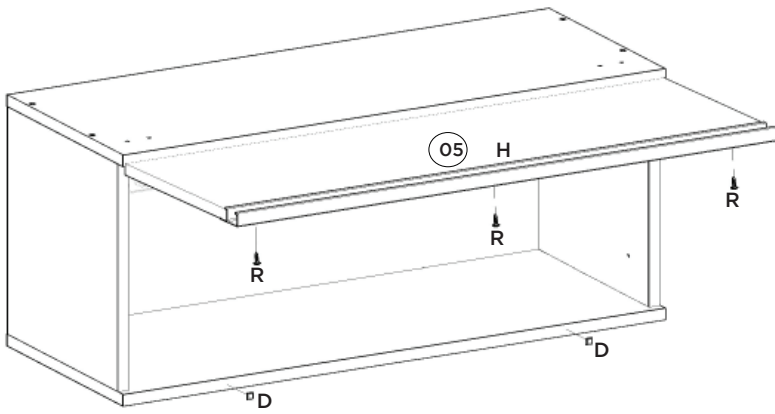
3^o

Video: Instalar e regular Dobradiças

Video: Instale y ajuste las bisagras

Video: Install and adjust hinges

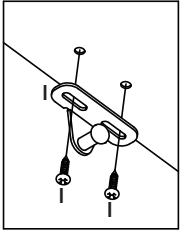
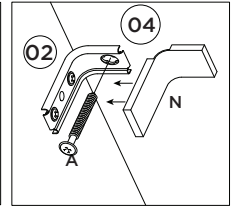
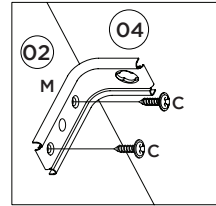
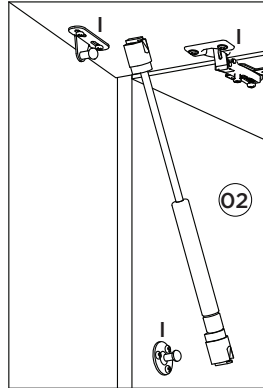
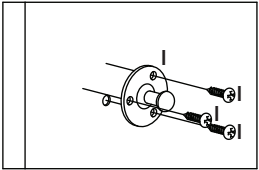
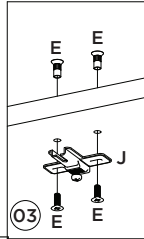
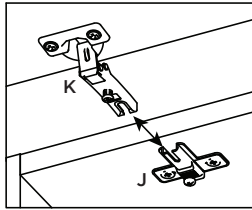
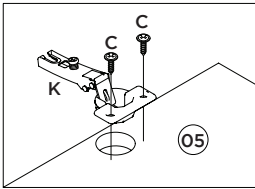

Video: Dicas para instalar o Kit Pistão à Gás

Video: Consejos para instalar el kit de pistón de gas

Video: Tips for installing the Gas Piston Kit

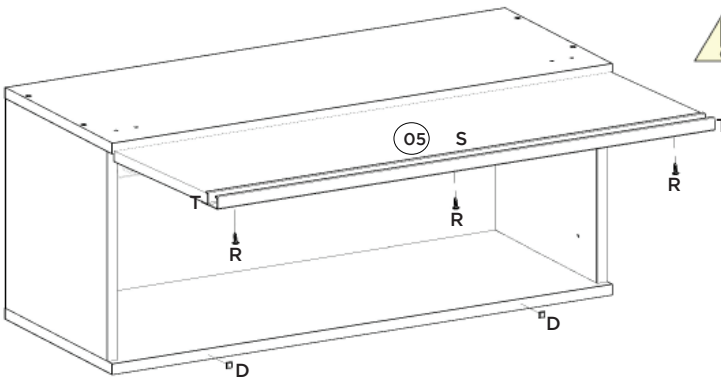

Somente para (C54-139)





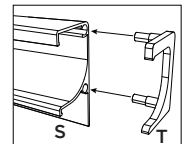







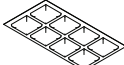

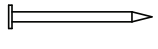

Solo para (C54-139)

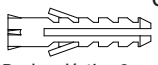
Only for (C54-139)

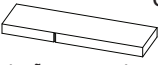

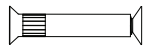

Item	Caixa Caja Box	Qtd Ctd Qty	Descrição Descripción Description	Medidas (mm) Dimensions (mm) Size (measurements) (mm)
01	1/1	01	Base Base Base	800x310x15
02	1/1	02	Lateral Direita Esquerda Lateral Derecha Izquierda Right Side Left	307x295x15
03	1/1	01	Tampo Tapa Top	800x310x15
04	1/1	01	Fundo Fondo Bottom	792x331x3
05	1/1	01	Porta Basculante Puerta Basculante Basculating Door	795x274x15
05	1/1	01	Porta Basculante Puerta Basculante Busculating Door (Somente para C54-139)	796x277x15

Ferragens | Herrajes | Hardware

A  Parafuso 5,0x50mm FLA. Tornillo 5,0x50mm FLA. Screw 5,0x50mm FLA.	02x	B  Parafuso 3,5x40mm CHT. Tornillo 3,5x40mm CHT. Screw 3,5x40mm CHT.	08x	C  Parafuso 3,5x14mm FLA. Tornillo 3,5x14mm FLA. Screw 3,5x14mm FLA.	08x	D  Batente PVC para Porta Parada de PVC para Puerta PVC Door Stop	02x	E  Parafuso União 15mm Tornillo Unión 15mm Union Screw 15mm	04x
F  Cavilha 8x25mm Cinta 8x25mm Dowel 8x25mm	08x	G  Prego 10x10mm Clavo 10x10mm Nail 10x10mm	20x	H  Puxador Alum. MOV 795mm Tirador Alum. MOV 795mm Handle Alum. MOV 795mm	01x	I  Kit Pistão a Gás 60N Kit Pistón a Gas 60N 60N Gas Piston Kit	01x	J  Calço metal Super Alto 8mm Calzado metálico Super Alto 8mm Super 8mm metal chock	02x
K  Dobradiça metal 35mm Alta Bisagras metálicas 35mm Alta Metal hinge 35mm High	02x	L  Bucha plástica 8mm Bucha de plástico 8mm 8mm plastic bushing	02x	M  Suporte de fixação Soporte de fijación Mounting bracket	02x	N  Proteção para cantoneira Ángulo de protección Protection angle	02x	O  Sachê de cola Bolsa de pegamento Glue bag	01x
P  Adesivo tapan de tornillo 10mm Bolt cover adhesive 10mm	08x	Q  Parafuso União 30mm Tornillo Unión 30mm Union Screw 30mm	04x	R  Parafuso 3,5x12mm CHT. Tornillo 3,5x12mm CHT. Screw 3,5x12mm CHT.	03x	S  Puxador MOV4083 - 792mm Tirador MOV4083 - 792mm MOV4083 - 792mm Handle	01x	T  Kit Ponteira Plastica MOV4083 Kit de punta de plástico MOV4083 Plastic Tip Kit MOV4083	01x

 O parafuso (Q) deve ser usada somente quando este módulo for acoplado a outro módulo componível Henn.

 El tornillo (Q) se debe utilizar sólo cuando el módulo está conectado a otro módulo componible Henn.

 The screw (Q) should be used only when this module is attached to another Henn modular module.

RECOMENDAÇÃO
Para fixar o móvel na parede usar o suporte de fixação (M), o parafuso 3,5x14mm FLA (C), a Bucha 8mm (L) e o parafuso 5,0x50mm FLA (A).

RECOMENDACIÓN
Para conectar el móvil a la pared con el soporte (M), tornillo 3,5 x14mm FLA (C), el casquillo de 8 mm (L) y el 5,0 x50mm tornillo FLA (A).

RECOMMENDATION
To fix the furniture to the wall use the fixing bracket (M), the 3.5x14mm FLA (C) screw, the 8mm bushing (L) and the 5.0x50mm FLA (A).

HENN

Ind. e Com. de Móveis Henn
Mondai - SC - Brasil

+55 49 3674.3500

@moveishenn
www.henn.com.br

INSTRUÇÕES DE MONTAGEM

INSTRUCCIONES DE MONTAJE
ASSEMBLY INSTRUCTIONS

Aéreo 01 Porta Basculante Vidro com Nicho Connect | 01 puerto de aire de camiones de cristal con el nicho Connect | 01 air port Glass Tipper Connect with Niche

- c C59-23 - Duna
- c C59-42 - Fend
- c C59-139 - Off White

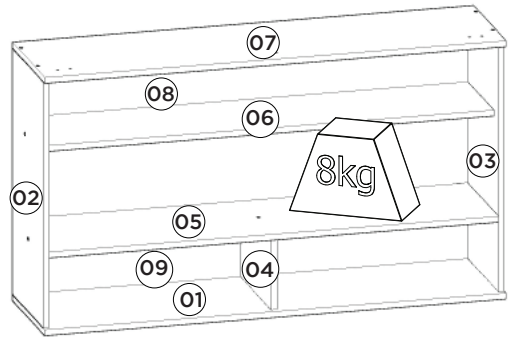
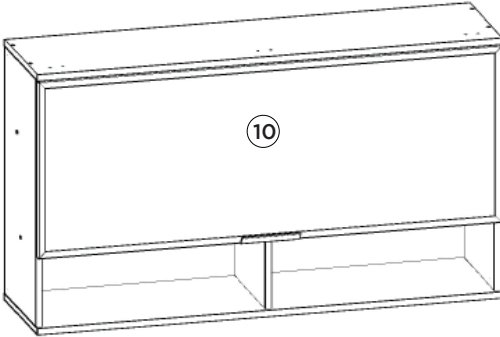

Pesos máximos recomendados com carga distribuída
Peso máximo recomendado con la carga distribuída
Recommended maximum weight with distributed load.

AVISO

Para limpeza de seu móvel, use uma flanela seca ou umedecida, e não utilize produtos químicos que possam danificar seu produto.

SISTEMA DE MONTAGEM

O sistema de montagem dos produtos, funciona de acordo com a ordem crescente dos números indicados no desenho. Ex: 01, 02, 03, 04... até a conclusão da montagem.

ASSISTÊNCIA TÉCNICA

Para solicitação de Assistência Técnica você consumidor deverá entrar em contato com o Lojista o qual você realizou a compra deste produto e solicitar a assistência técnica das peças avariadas. A garantia abrange todas as peças, partes e componentes que eventualmente venham apresentar defeito de fabricação no prazo de 03 (três) meses, contando a partir da entrega do produto ao consumidor, mediante nota fiscal de compra. Se houver qualquer alteração na estrutura do produto ou ocorrer defeito por negligência do montador/consumidor em relação a instrução de montagem e manuseio, não será fornecido assistência técnica gratuita.

ADVERTENCIA

Para limpieza de su móvil, use una flanela seca o húmeda, y no utilice productos químicos que puedan dañar su producto.

SISTEMA DE MONTAJE

El sistema de montaje de los productos funciona de acuerdo con el orden creciente de los números indicados en el dibujo. Ej.: 01, 02, 03, 04... hasta la conclusión del montaje.

ASISTENCIA TÉCNICA

Para solicitar Asistencia Técnica, el consumidor debe comunicarse con el Comercio que usted realizó la compra de este producto y solicita asistencia técnica para las partes dañadas. La garantía cubre todas las partes, piezas y componentes que eventualmente puedan presentar defecto de fabricación en el plazo de 03 (tres) meses, contados a partir de la entrega del producto al consumidor, mediante factura de compra. Si se produce algún cambio en la estructura del producto o se produce un defecto por negligencia del montador/consumidor en relación con las instrucciones de montaje y manipulación, no se prestará asistencia técnica gratuita.

NOTICE

To clean your furniture, use a dry or wet cloth, and do not use chemicals that may damage your product.

ASSEMBLY SYSTEM

The products' assembly system works according to the increasing order of the indicated numbers. For example: 01, 02, 03, 04 ... to the end of the assembly.

TECHNICAL ASSISTANCE

To request Technical Assistance, the consumer must contact the retailer from whom you purchased this product and request technical assistance for the damaged parts. The warranty covers all parts, parts and components that may eventually present a manufacturing defect within a period of 03 (three) months, counting from the delivery of the product to the consumer, by means of a purchase invoice. If there is any change in the structure of the product or defect occurs due to negligence of the assembler/consumer in relation to the assembly and handling instruction, free technical assistance will not be provided.

Requisitos para montagem
Requisitos para la montaje
Assembly Requirements

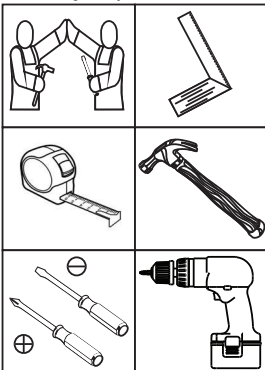

Imagens meramente ilustrativas
Imágenes meramente ilustrativas
Images for illustration only

1º

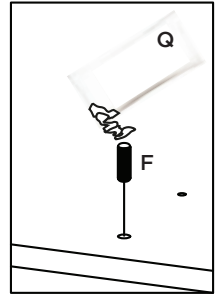
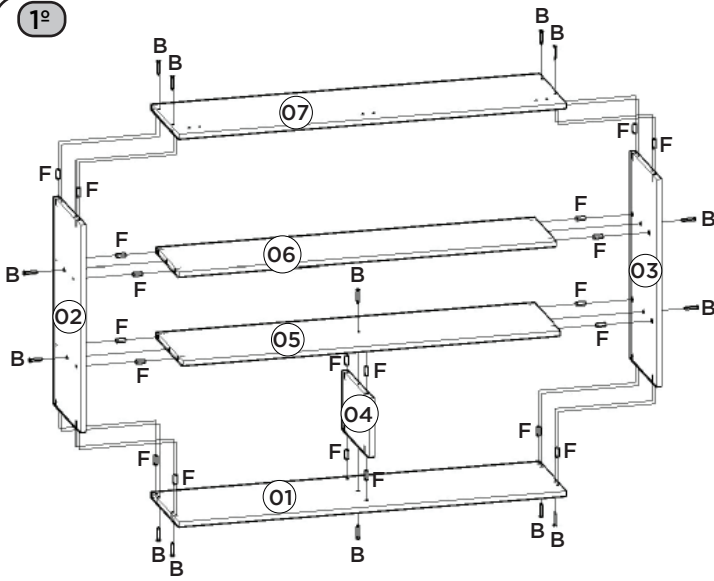

Utilizar o sachê de cola (Q) em todas as cavilhas (F) do produto.

Con el pegamento sobre (Q) en todos los pernos (F) producto.

Use the glue sachet (Q) on all the pegs (F) of the product.

2º

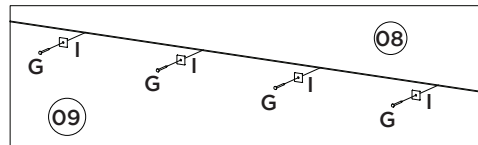
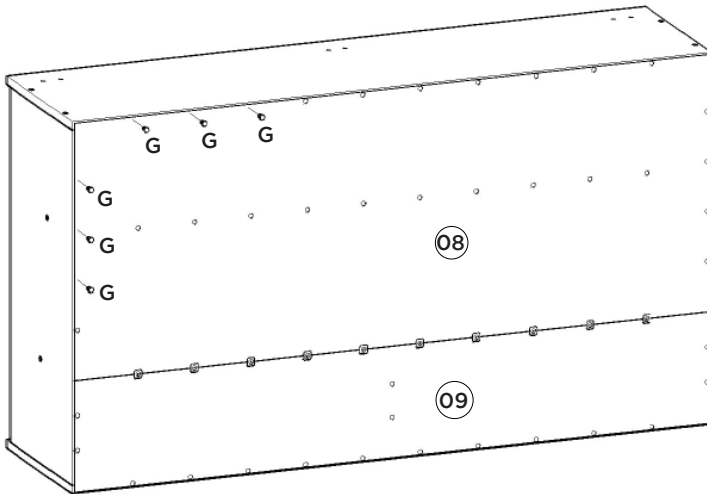

3º Regulagem do pistão sempre o mais distante possível da dobradiça. Ajuste de pistón siempre en la medida de lo posible, la bisagra.

Adjust the piston as far as possible from the hinge.

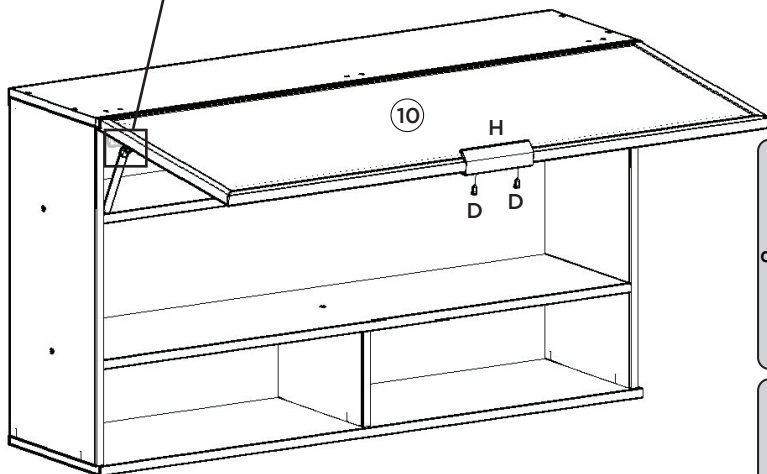

Regulagem do parafuso da dobradiça no máximo para dentro, afastando a porta do tampo, isso apenas nas duas extremidades da porta. Já na dobradiça central da porta o parafuso deverá ficar na regulagem normal (no meio).

Ajuste del tornillo de la bisagra en el máximo hacia dentro, alejando la puerta de la tapa, sólo en los dos extremos de la puerta. En la bisagra central de la puerta, el tornillo deberá quedar en la regulación normal (en el centro).

Adjusting the hinge bolt to maximum inside, pushing the door off the top, this only at both ends of the door. In the central hinge of the door the bolt should be in the normal setting (in the middle).



Video: Instalar e regular Dobradiças

Video: Instale y ajuste las bisagras

Video: Install and adjust hinges

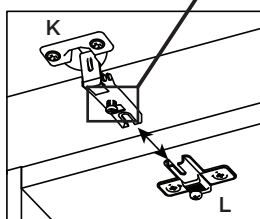
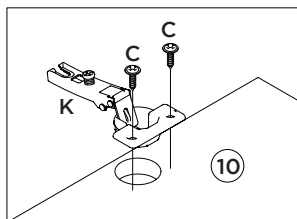
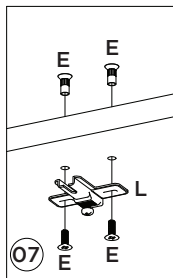

Video: Dicas para instalar o Kit Pistão à Gás





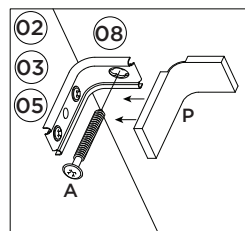
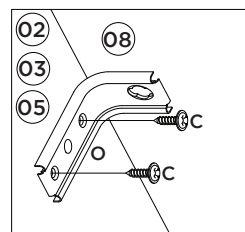
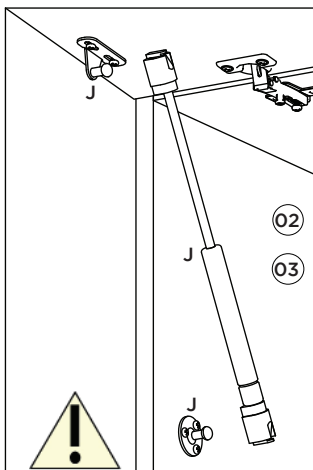
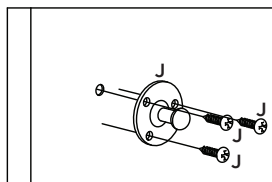
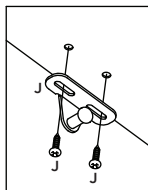





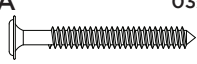

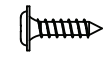



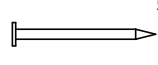



Video: Consejos para instalar el kit de pistón de gas

Video: Tips for installing the Gas Piston Kit



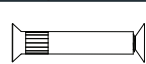

Item	Caixa Caja Box	Qtd Ctd Qty	Descrição Descripción Description	Medidas (mm) Dimensions (mm) Size (measurements) (mm)
01	1/1	01	Base Base Base	1200x310x15
02	1/1	01	Lateral esquerda Lateral izquierda Left side	645x295x15
03	1/1	01	Lateral direita Lateral derecha Right side	645x295x15
04	1/1	01	Divisória Tabique Partition	293x183x15
05	1/1	01	Base Porta Basculante Base Puerta Basculante Basculating Door Base	1168x295x15
06	1/1	01	Prateleira Estante Shelf	1168x250x15
07	1/1	01	Tampo Tapa Top	1200x310x15
08	1/1	01	Fundo Fondo Bottom	1192x466x3
09	1/1	01	Fundo Estreito Fondo Estrecho Narrow Bottom	1192x202x3
10	1/1	01	Porta de Vidro Reflecta Puerta de cristal reflectante Reflecta Glass Door	1195x458x20

Ferragens | Herrajes | Hardware

A  Parafuso 5,0x50mm FLA. Tornillo 5,0x50mm FLA. Screw 5,0x50mm FLA.	B  Parafuso 3,5x40mm CHT. Tornillo 3,5x40mm CHT. Screw 3,5x40mm CHT.	C  Parafuso 3,5x12mm FLA. Tornillo 3,5x12mm FLA. Screw 3,5x12mm FLA.	D  Parafuso 3,5x12mm CHT. Tornillo 3,5x12mm CHT. Screw 3,5x12mm CHT.	E  Parafuso União 15mm Tornillo Unión 15mm Union Screw 15mm
F  Cavilha 8x25mm Cinta 8x25mm Dowel 8x25mm	G  Prego 10x10mm Clavo 10x10mm Nail 10x10mm	H  Perfil Puxador 2015 - 150mm Perfil de Tirador 2015 - 150mm Profile Handle 2015 - 150mm	I  Fixador de fundos Fijador de fondos Bottom fixer	J  Kit Pistão a Gás 60N Kit Pistón a Gas 60N 60N Gas Piston Kit
K  Dobradiça metal 35mm Alta Bisagras metálicas 35mm Alta Metal hinge 35mm High	L  Calço metal Super Alto 8mm Calzado metálico Super Alto 8mm Super 8mm metal chock	M  Batente PVC para Porta Parada de PVC para Puerta PVC Door Stop	N  Buchas plásticas 8mm Bucha de plástico 8mm 8mm plastic bushing	O  Suporte de fixação Soporte de fijación Mounting bracket
P  Proteção para cantoneira Ángulo de protección Protection angle	Q  Sachê de cola Bolsa de pegamento Glue bag	R  Adesivo tampa parafuso 10mm Adhesivo tapón de tornillo 10mm Bolt cover adhesive 10mm	S  Parafuso União 30mm Tornillo Unión 30mm Union Screw 30mm	T  Giz de correção Tiza de corrección Chalk of correction
U  Etiqueta resinada Henn Etiqueta resinada Henn Henn resin label				

 O parafuso (S) deve ser usada somente quando este módulo for acoplado a outro módulo componível Henn.

 El tornillo (S) se debe utilizar sólo cuando el módulo está conectado a otro módulo componible Henn.

 The screw (S) should be used only when this module is attached to another Henn modular module.

RECOMENDAÇÃO

Para fixar o móvel na parede usar o suporte de fixação (O), o parafuso 3,5x12mm FLA (C), a Bucha 8mm (N) e o parafuso 5,0x50mm FLA (A).

RECOMENDACIÓN

Para conectar el móvil a la pared con el soporte (O), tornillo 3,5 x12mm FLA (C), el casquillo de 8 mm (N) y el 5,0 x50mm tornillo FLA (A).

RECOMENDATION

To fix the furniture to the wall use the fixing bracket (O), the 3.5x12mm FLA (C) screw, the 8mm bushing (N) and the 5.0x50mm FLA (A).

HENNInd. e Com. de Móveis Henn
Mondai - SC - Brasil

☎ +55 49 3674.3500

📧 @moveishenn
www.henn.com.br**INSTRUÇÕES DE MONTAGEM****INSTRUCCIONES DE MONTAJE
ASSEMBLY INSTRUCTIONS****BALCÃO 2 PORTAS 800MM CONNECT | BALCÓN 2 PUERTAS 800MM CONNECT |
BALCONY 2 DOORS 800MM CONNECT****Referência/Cor**

- C64-35 - Duna/Cristal
 C64-42 - Fendi
 C64-139 - Off White

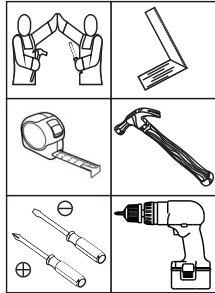
**Requisitos para montagem
Requisitos para la montaje
Assembly Requirements**

Imagens meramente ilustrativas, não acompanha o produto.
 Imágenes ilustrativas, no incluidas con el producto.
 Illustrative images, not included with the product.

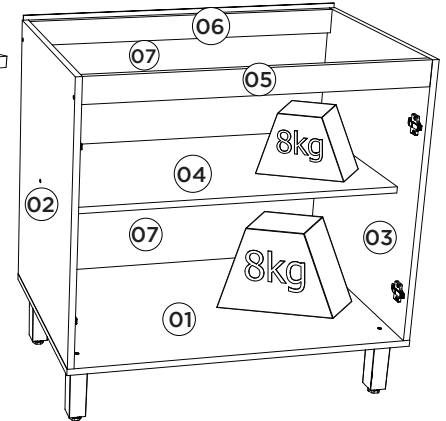
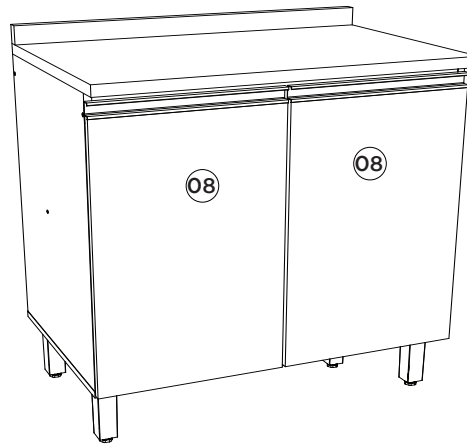

**Pesos máximos recomendados com carga distribuída
 Peso máximo recomendado con la carga distribuida
 Recommended maximum weights with evenly distributed.**

Lista de Peças | Lista de piezas | List of parts

Item	Caixa Caja Box	Qtd Ctd Qty	Descrição Descripción Description	Medidas (mm) Dimensions (mm) Size (measurements) (mm)
01	1/1	01	Base Base Base	800x490x15
02	1/1	01	Lateral esquerda Lateral izquierda Left side	660x490x15
03	1/1	01	Lateral direita Lateral derecha Right side	660x490x15
04	1/1	01	Prateleira Estante Shelf	768x400x15
05	1/1	01	Travessa frontal Travesaño frontal Front crossbar	768x60x15
06	1/1	01	Travessa traseira Travesaño trasero Rear bumper	768x60x15
07	1/1	02	Fundo Fondo Bottom	792x341x3
08	1/1	02	Porta Puerta Door	625x396x15
08	1/1	02	Porta Puerta Door (Somente para C64-139)	629x396x15

AVISO
 Para limpeza de seu móvel, use uma favela seca ou umedecida, e não utilize produtos químicos que possam danificar seu produto.

SISTEMA DE MONTAGEM
 O sistema de montagem dos produtos, funciona de acordo com a ordem crescente dos números indicados no desenho. Ex: 01, 02, 03, 04... até a conclusão da montagem.

ASSISTÊNCIA TÉCNICA
 Para solicitação de Assistência Técnica você consumidor deverá entrar em contato com o Lojista o qual você realizou a compra deste produto e solicitar a assistência técnica das peças avariadas. A garantia abrange todas as peças, partes e componentes que eventualmente venham apresentar defeito de fabricação no prazo de 03 (três) meses, contando a partir da entrega do produto ao consumidor, mediante nota fiscal de compra. Se houver qualquer alteração na estrutura do produto ou ocorrer defeito por negligência do montador/consumidor em relação a instrução de montagem e manuseio, não será fornecido assistência técnica gratuita.

ADVERTENCIA
 Para limpieza de su móvil, use una favela seca o húmeda, y no utilice productos químicos que puedan dañar su producto.

SISTEMA DE MONTAJE
 El sistema de montaje de los productos funciona de acuerdo con el orden creciente de los números indicados en el dibujo. Ej: 01, 02, 03, 04... hasta la conclusión del montaje.

ASSISTENCIA TÉCNICA
 Para solicitar Asistencia Técnica, el consumidor debe comunicarse con el Comercio que usted realizó la compra de este producto y solicita asistencia técnica para las partes dañadas. La garantía cubre todas las partes, piezas y componentes que eventualmente puedan presentar defecto de fabricación en el plazo de 03 (tres) meses, contados a partir de la entrega del producto al consumidor, mediante factura de compra. Si se produce algún cambio en la estructura del producto o se produce un defecto por negligencia del montador/consumidor en relación con las instrucciones de montaje y manipulación, no se prestará asistencia técnica gratuita.

NOTICE
 To clean your furniture, use a dry or wet cloth, and do not use chemicals that may damage your product.

ASSEMBLY SYSTEM
 The products' assembly system works according to the increasing order of the indicated numbers. For example: 01, 02, 03, 04 ... to the end of the assembly.

TECHNICAL ASSISTANCE
 To request Technical Assistance, the consumer must contact the retailer from whom you purchased this product and request technical assistance for the damaged parts. The warranty covers all parts, parts and components that may eventually present a manufacturing defect within a period of 03 (three) months, counting from the delivery of the product to the consumer, by means of a purchase invoice. If there is any change in the structure of the product or defect occurs due to negligence of the assembler/consumer in relation to the assembly and handling instruction, free technical assistance will not be provided.

Ferragens | Herrajes | Hardware

A Parafuso 7,0x40mm CHT. Tornillo 7,0x40mm CHT. Screw 7,0x40mm CHT.	B Parafuso 5,0x50mm FLA. Tornillo 5,0x50mm FLA. Screw 5,0x50mm FLA.	C Parafuso 4,5x50mm CHT. Tornillo 4,5x50mm CHT. Screw 4,5x50mm CHT.	D Parafuso 3,5x40mm CHT. Tornillo 3,5x40mm CHT. Screw 3,5x40mm CHT.	E Parafuso 3,5x14mm FLA. Tornillo 3,5x14mm FLA. Screw 3,5x14mm FLA.	F Parafuso 3,5x12mm CHT. Tornillo 3,5x12mm CHT. Screw 3,5x12mm CHT.	G Parafuso União 30mm Tornillo Unión 30mm Union Screw 30mm	H Cavilha 8x25mm Cinta 8x25mm Dowel 8x25mm
I Prego 10x10mm Clavo 10x10mm Nail 10x10mm	J Fixador de fundos Fijador de fondos Bottom fixer	K Cantoneira plástica Cantoneira plástica Plastic angle brackets	L Pé 145mm x 42mm Pie 145mm x 42mm Foot 145mm x 42mm	M Puxador MOV 396mm Tirador MOV 396mm MOV 396mm Handle	N Calço metal médio 0mm Calzón de metal medio 0mm Shim metal middle 0mm	O Dobradiça metal 35mm Colo Baixo Bisagra de metal 35mm Colo Bajo Metal hinge 35mm Colo Low	P Batente PVC para Porta Parada de PVC para Puerta PVC Door Stop
Q Buchas plásticas 8mm Buchas de plástico 8mm 8mm plastic bushing	R Suporte de fixação Soporte de fijación Mounting bracket	S Proteção para cantoneira Ángulo de protección Protection angle	T Giz de correção Tiza de corrección Chalk of correction	U Sachê de cola Bolsa de pegamento Glue bag	V Adesivo tapa parafuso 10mm Adhesivo tapón de tornillo 10mm Bolt cover adhesive 10mm	W Adesivo tapa parafuso 17mm Adhesivo tapón de tornillo 17mm Bolt cover adhesive 17mm	X Puxador MOV4083 - 392mm Tirador MOV4083 - 392mm MOV4083 - 392mm Handle
Y Kit Ponta Plástica MOV4083 Kit de punta de plástico MOV4083 Plastic Tip Kit MOV4083							

O parafuso (G) deve ser usada somente quando este módulo for acoplado a outro módulo componível Henn.

El tornillo (G) se debe utilizar sólo cuando el módulo está conectado a otro módulo componible Henn.

The screw (G) should be used only when this module is attached to another Henn modular module.

RECOMENDAÇÃO

Para fixar o móvel na parede usar o suporte de fixação (R), o parafuso 3,5x14mm FLA (E), a Bucha 8mm (Q) e o parafuso 5,0x50mm FLA (B).

RECOMENDACIÓN

Para conectar el móvil a la pared con el soporte (R), tornillo 3,5 x14mm FLA (E), el casquillo de 8 mm (Q) y el 5,0 x50mm tornillo FLA (B).

RECOMMENDATION

To fix the furniture to the wall use the mounting bracket (R), the 3.5x14mm FLA (E) screw, the 8mm bushing (Q) and the 5.0x50mm FLA (B).

1

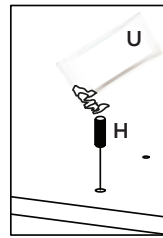
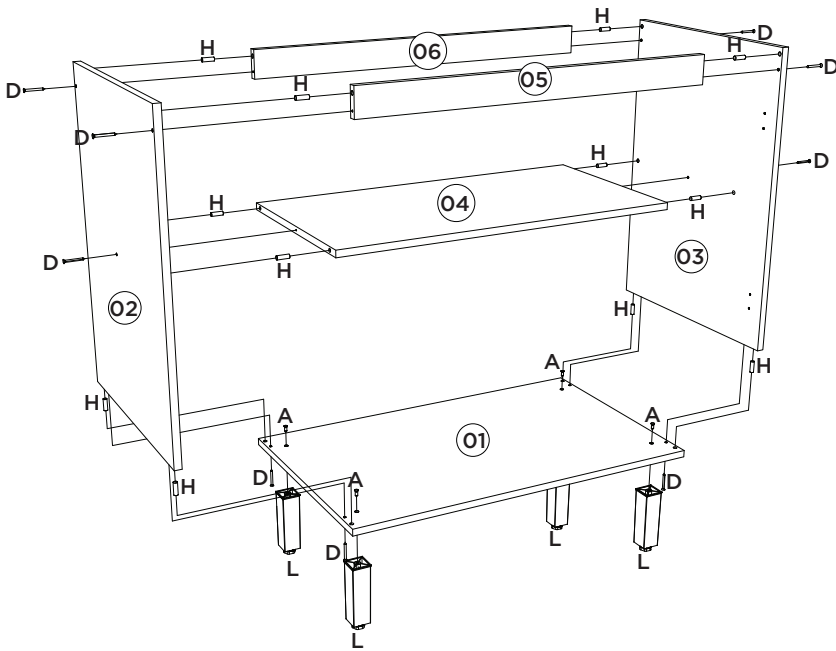

Utilizar o sachê de cola (U) em todas as cavilhas (H) do produto.

Con el pegamento sobre (U) en todos los pernos (H) producto.

Use the glue sachet (U) on all the pegs (H) of the product.

2

Esse tampo é opcional e é vendido separadamente (C904-33).

Esta vez es opcional y se vende por separado (C904-33).

This top is optional and is sold separately (C904-33).

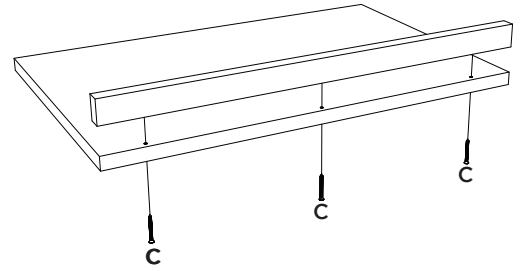

3

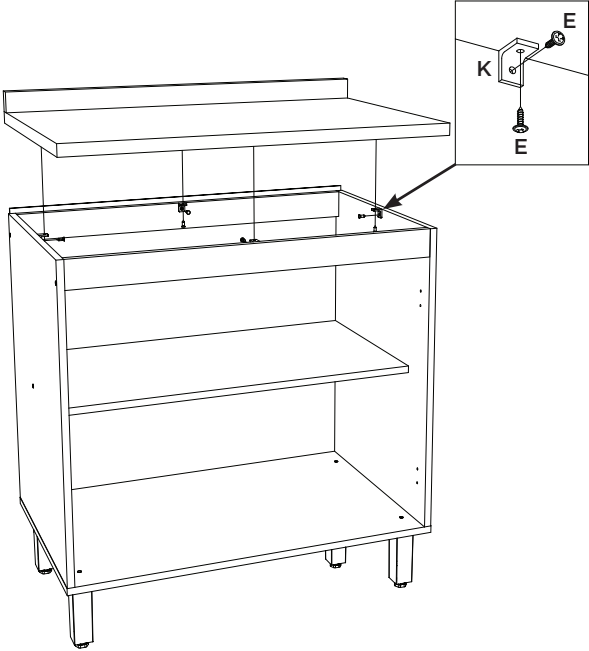

4

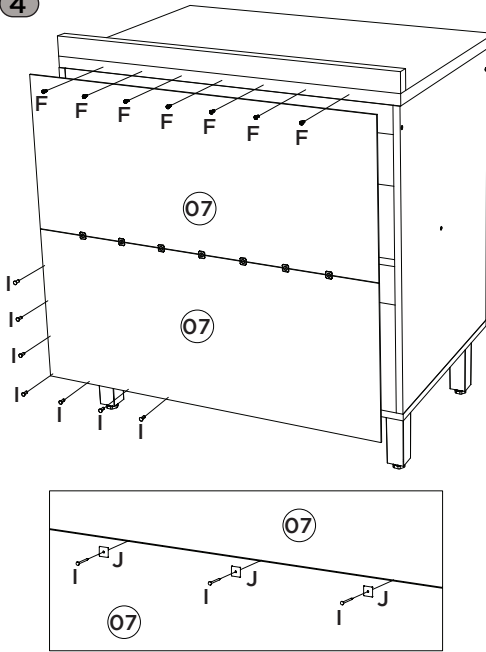

5

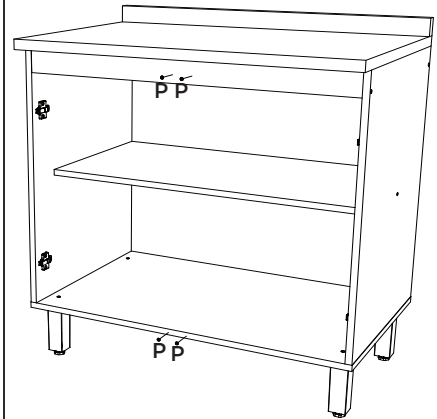

6

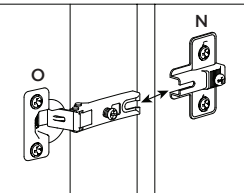
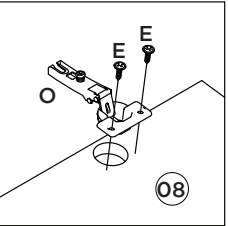
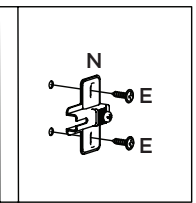

Video: Instalar e regular Dobradiças

Video: Instale y ajuste las bisagras

Video: Install and adjust hinges

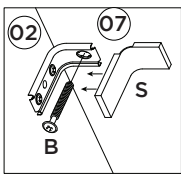
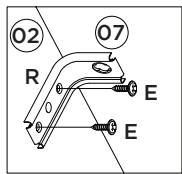

Somente para (C64-139)

Solo para (C64-139)

Only for (C64-139)

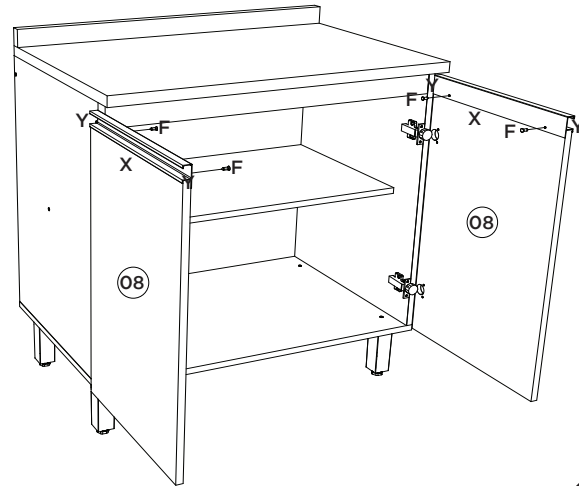
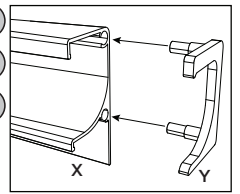

Balcão Pia 02 Gavetas 03 Portas Connect

Pia Contador 02 Cajones 03 Puertas Connect | Balcony Pia 02 Drawers 03 Doors Connect

C66-35 Duna/Cristal | C66-42 Fendi

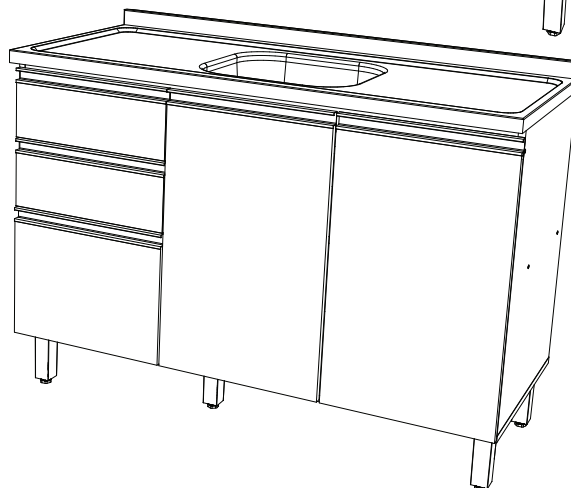
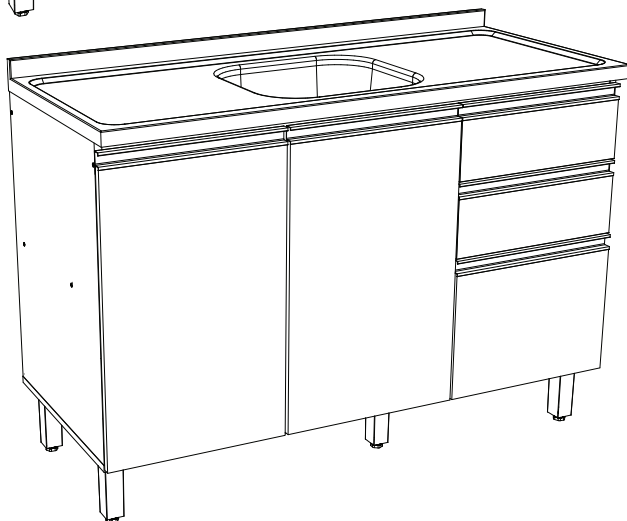
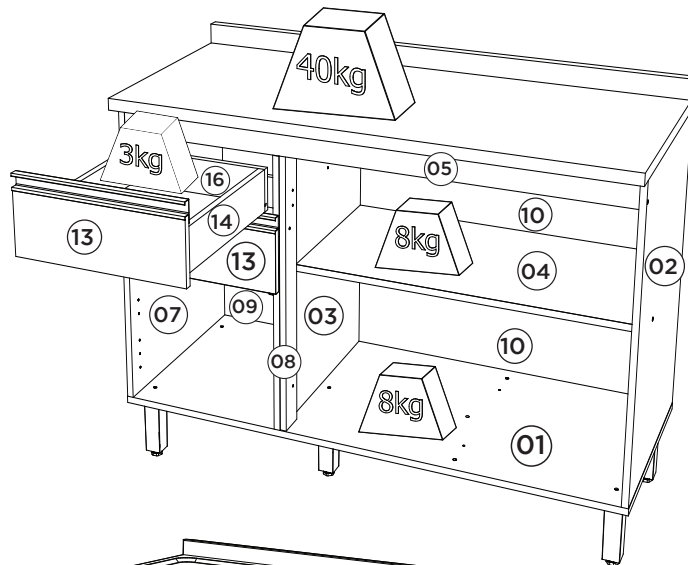
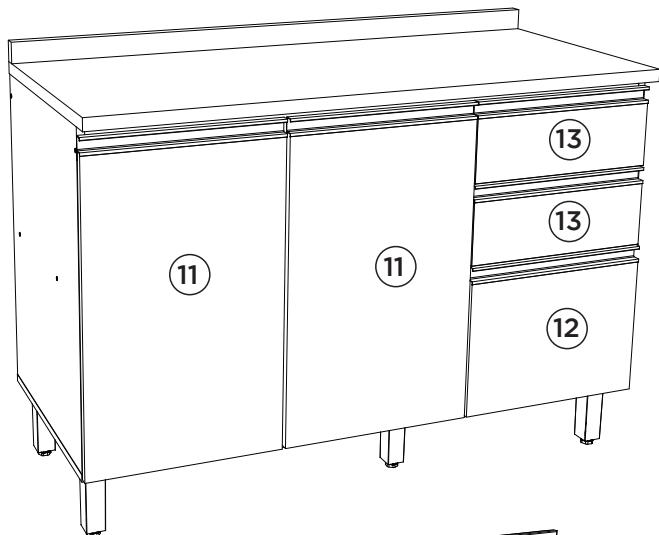

Pesos máximos recomendados com carga distribuída
Peso máximo recomendado con la carga distribuida
Recommended maximum weights with evenly distributed.

Requisitos para montagem Requisitos para la montaje Assembly Requirements

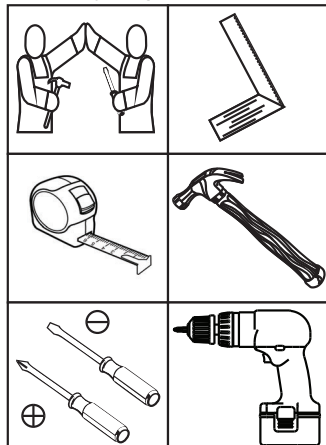

Imagens meramente ilustrativas, não acompanha o produto.
Imágenes ilustrativas, no incluidas con el producto.
Illustrative images, not included with the product.

AVISO

Para limpeza de seu móvel, use uma flanela seca ou umedecida, e não utilize produtos químicos que possam danificar seu produto.

SISTEMA DE MONTAGEM

O sistema de montagem dos produtos, funciona de acordo com a ordem crescente dos números indicados no desenho. Ex: 01, 02, 03, 04... até a conclusão da montagem.

ASSISTÊNCIA TÉCNICA

Para solicitação de Assistência Técnica você consumidor deverá entrar em contato com o Lojista o qual você realizou a compra deste produto e solicitar a assistência técnica das peças avariadas. A garantia abrange todas as peças, partes e componentes que eventualmente venham apresentar defeito de fabricação no prazo de 03 (três) meses, contando a partir da entrega do produto ao consumidor, mediante nota fiscal de compra. Se houver qualquer alteração na estrutura do produto ou ocorrer defeito por negligência do montador/consumidor em relação a instrução de montagem e manuseio, não será fornecido assistência técnica gratuita.

ADVERTENCIA

Para limpieza de su móvil, use una flanela seca o húmeda, y no utilice productos químicos que puedan dañar su producto.

SISTEMA DE MONTAJE

El sistema de montaje de los productos funciona de acuerdo con el orden creciente de los números indicados en el dibujo. Ej.: 01, 02, 03, 04... hasta la conclusión del montaje.

ASISTENCIA TÉCNICA

Para solicitar Asistencia Técnica, el consumidor debe comunicarse con el Comercio que usted realizó la compra de este producto y solicita asistencia técnica para las partes dañadas. La garantía cubre todas las partes, piezas y componentes que eventualmente puedan presentar defecto de fabricación en el plazo de 03 (tres) meses, contados a partir de la entrega del producto al consumidor, mediante factura de compra. Si se produce algún cambio en la estructura del producto o se produce un defecto por negligencia del montador/consumidor en relación con las instrucciones de montaje y manipulación, no se prestará asistencia técnica gratuita.

NOTICE

To clean your furniture, use a dry or wet cloth, and do not use chemicals that may damage your product.

ASSEMBLY SYSTEM

The products' assembly system works according to the increasing order of the indicated numbers. For example: 01, 02, 03, 04 ... to the end of the assembly.

TECHNICAL ASSISTANCE

To request Technical Assistance, the consumer must contact the retailer from whom you purchased this product and request technical assistance for the damaged parts. The warranty covers all parts, parts and components that may eventually present a manufacturing defect within a period of 03 (three) months, counting from the delivery of the product to the consumer, by means of a purchase invoice. If there is any change in the structure of the product or defect occurs due to negligence of the assembler/consumer in relation to the assembly and handling instruction, free technical assistance will not be provided.

1º

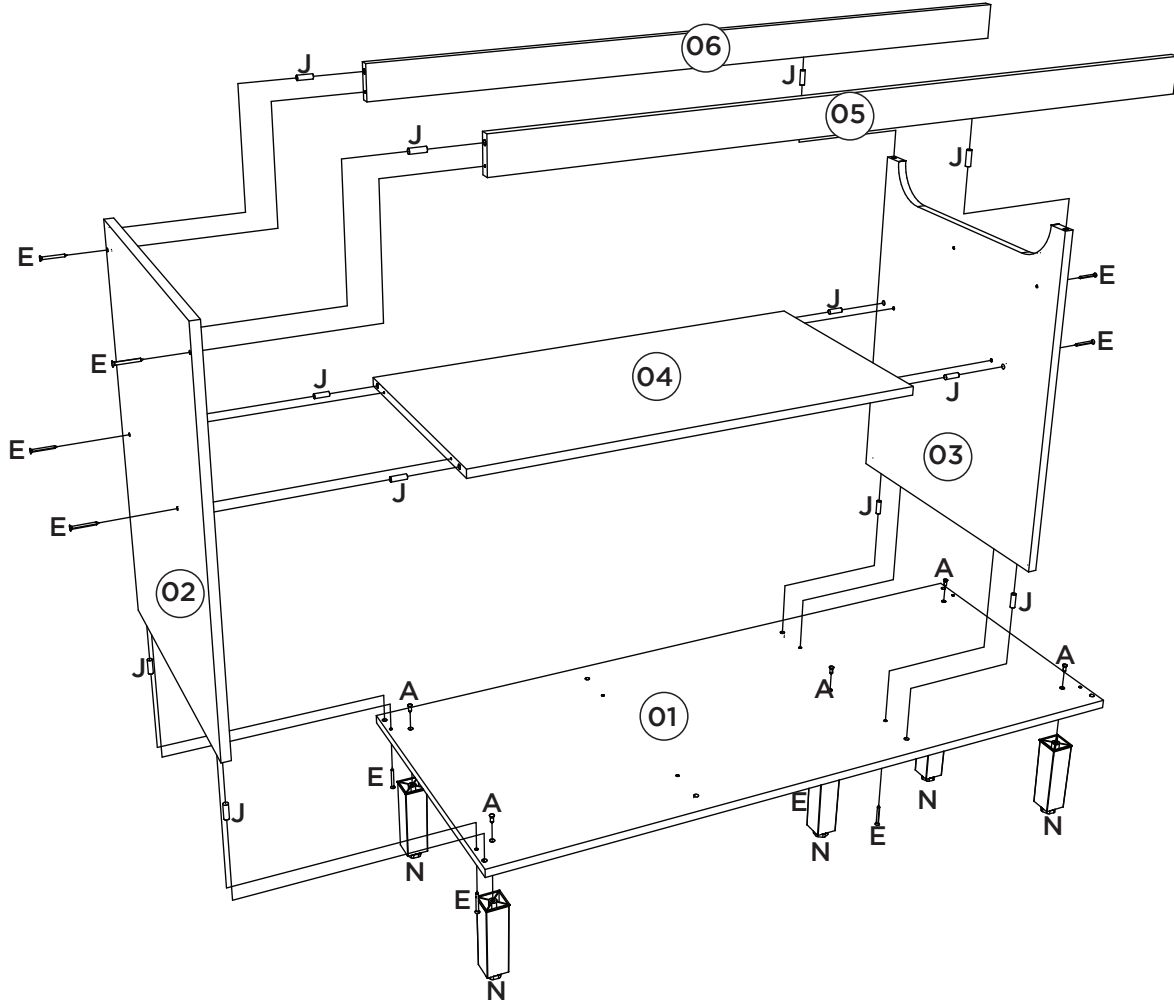

2º

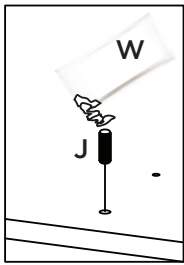

Utilizar o sachê de cola (W) em todas as cavilhas (J) do produto.

Con el pegamento sobre (W) en todos los pernos (J) producto.

Use the glue sachet (W) on all the pegs (J) of the product.

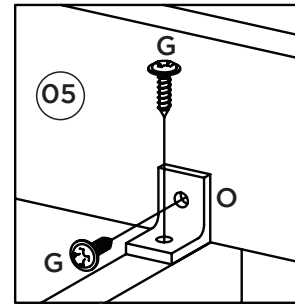

A pilastra da porta (08) deve estar alinhada com a divisão (03).

El pilar de la puerta (08) debe estar alineada con la división (03).

The door pillar (08) must be aligned with the partition (03).

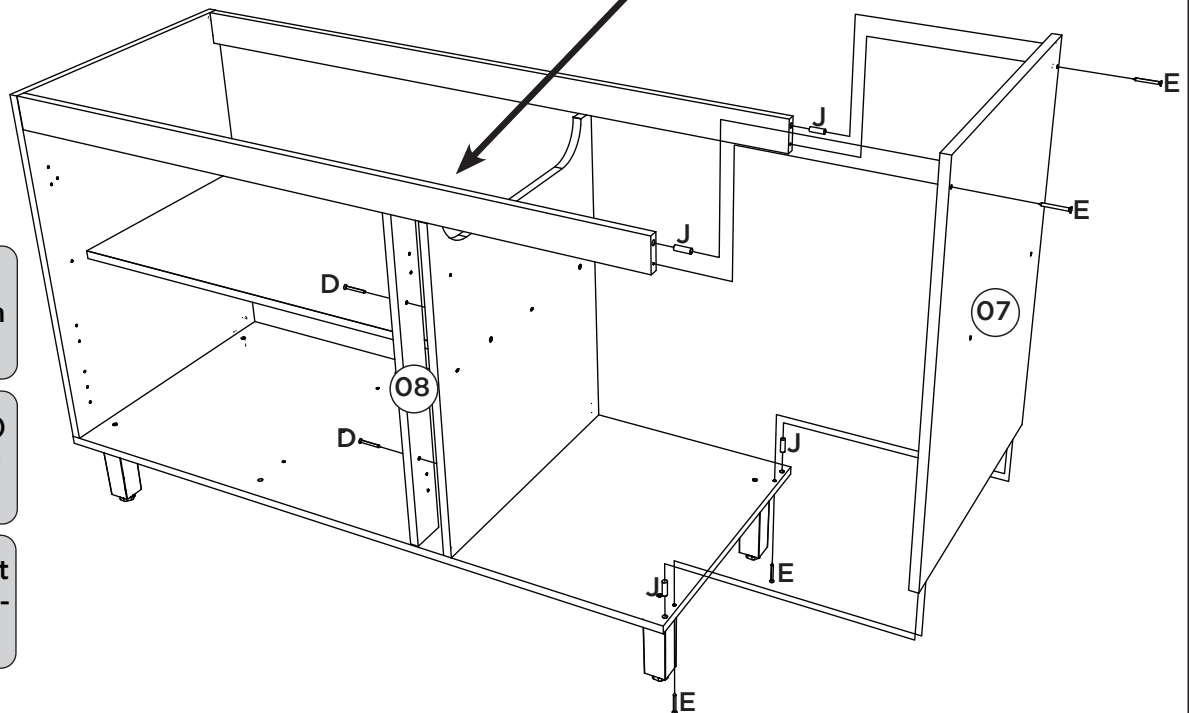

3º

Esse tampo é opcional e é vendido separadamente (C905-33).

Esta vez es opcional y se vende por separado (C905-33).

This top is optional and is sold separately (C905-33).

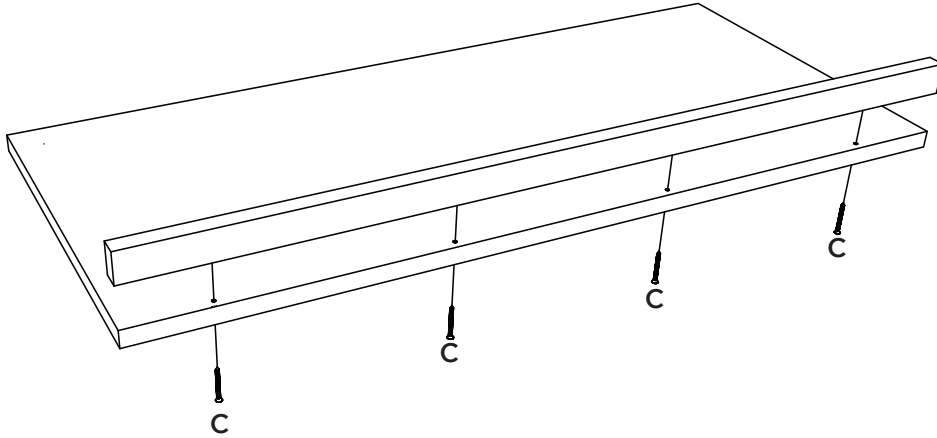

4º

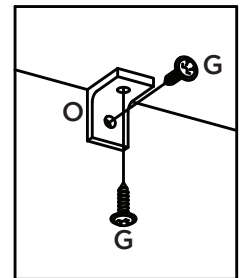

Caso o móvel seja montado com a opção do tampo, fixar o mesmo com 06 cantoneiras (O) e os parafusos 3,5x14mm (G).

Si se monta el auricular con la opción de la cubierta, fijarlo con Los ángulos 06 (O) y 3,5 x14mm tornillos (G).

If the furniture is to be installed with the top cover option, fix it with 06 (O) and 3.5x14mm screws (G).

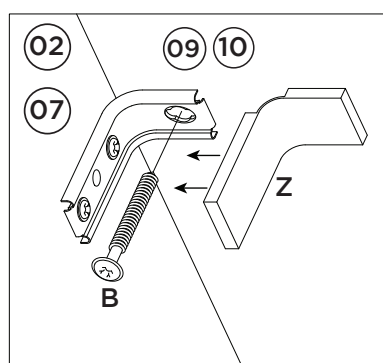
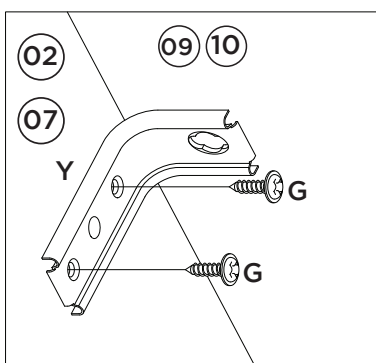
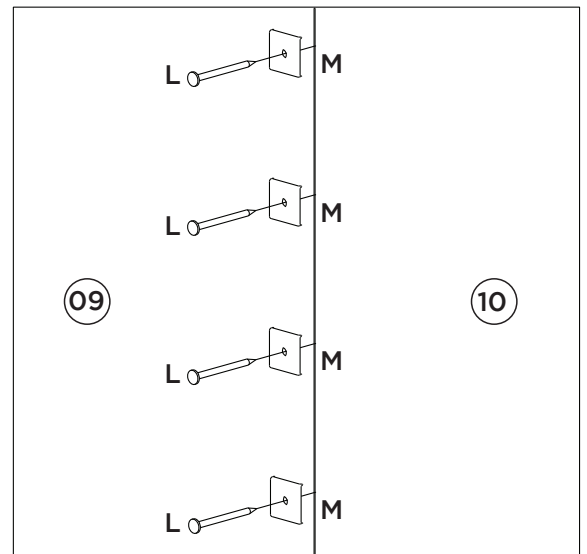
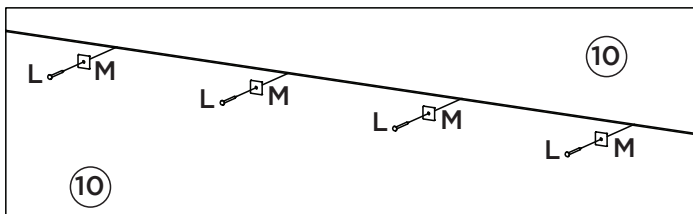
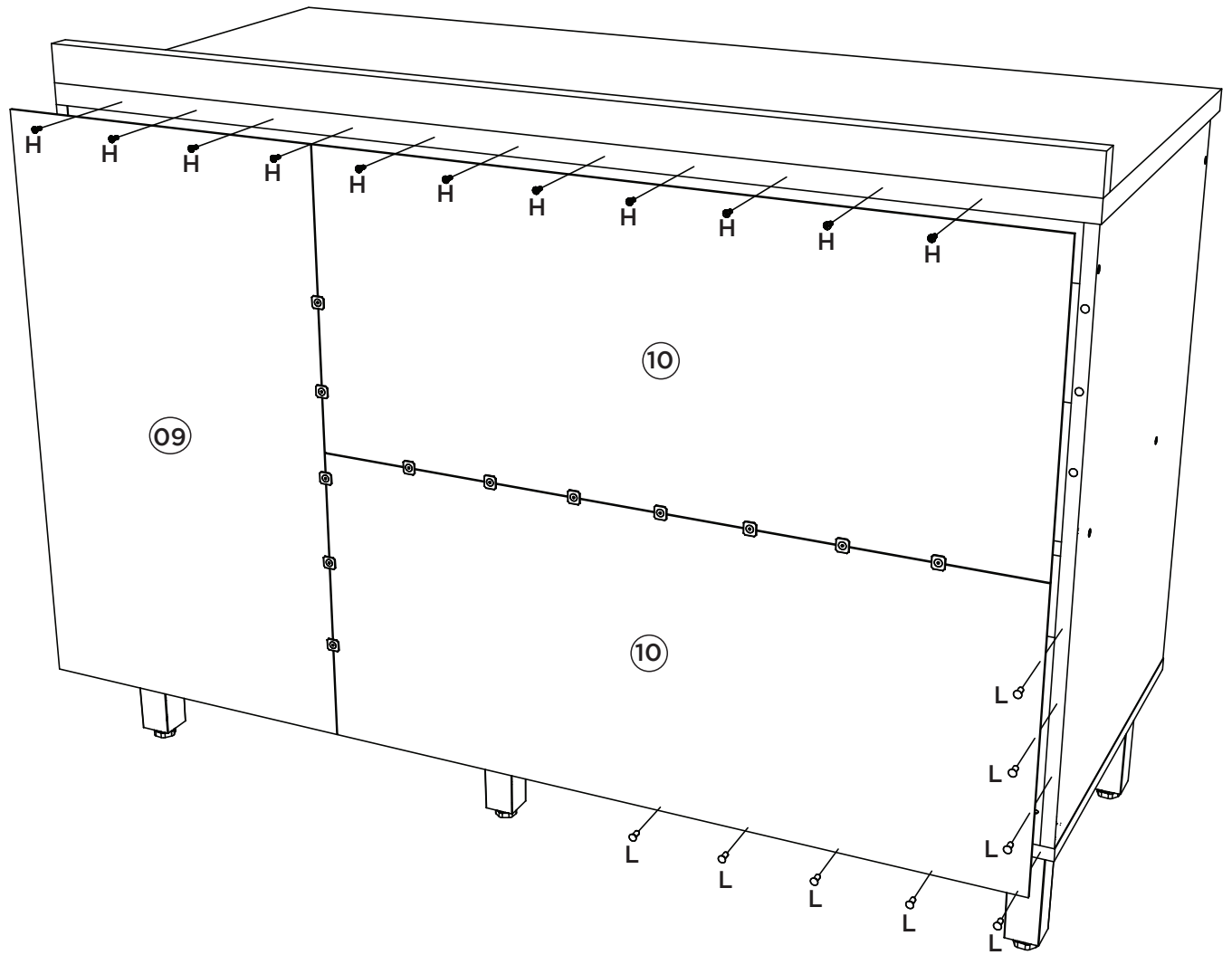

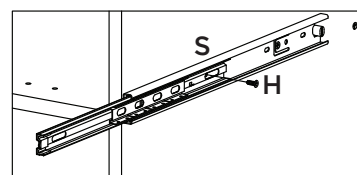
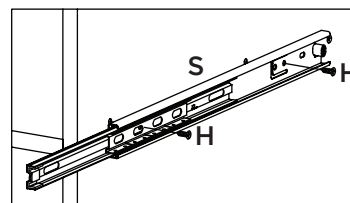
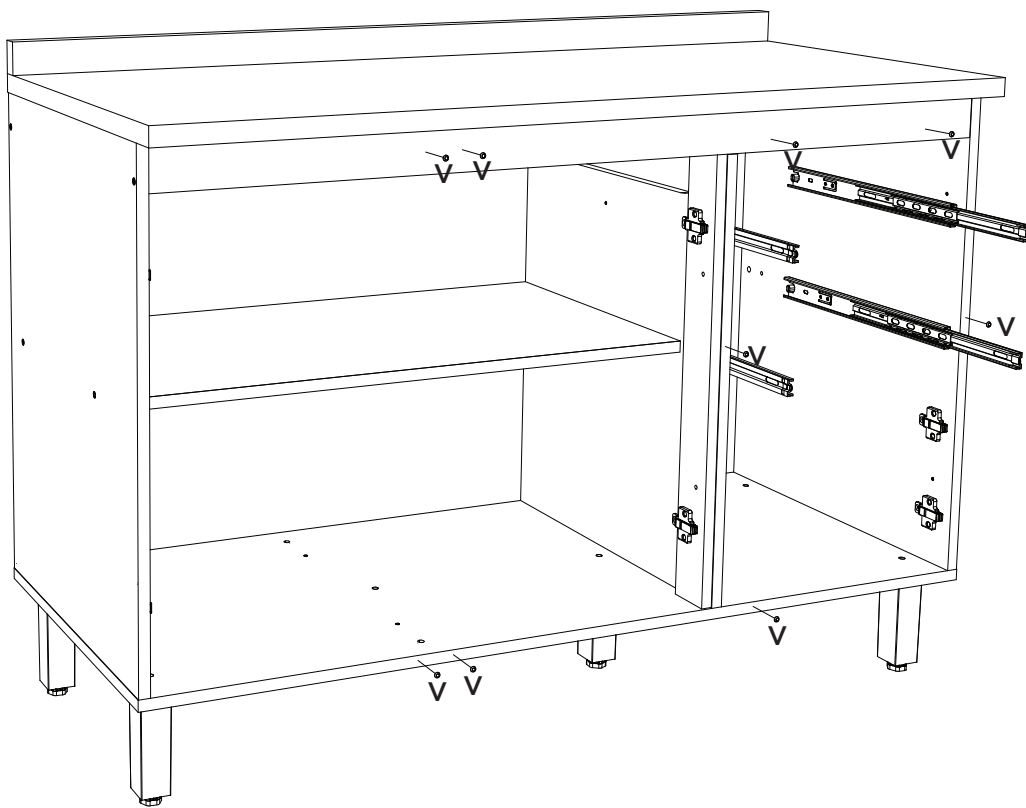

Fixação da corrediça telescópica (S).

Fijación Slide telescópico (S).

Fixing of the telescopic slide (S).

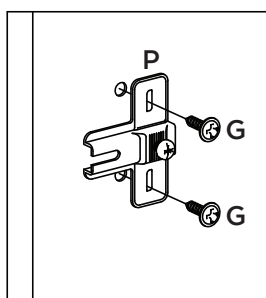

Fixação do calço 5mm (P).

Montaje de la placa de 5mm (P).

Shim fixation 5mm (P).

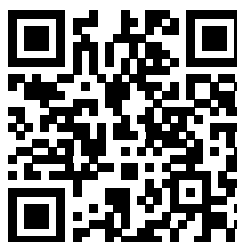

Vídeo: Dicas para fixar a Corrediça

Video: Consejos para arreglar la diapositiva

Video: Tips for Fixing the Slide

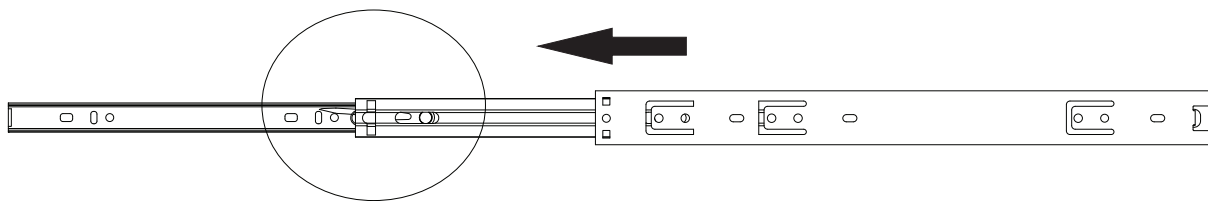

Para a desmontagem da corrediça siga a instrução ao lado.

Para el desmontaje seguimiento de diapositivas la instrucción siguiente a.

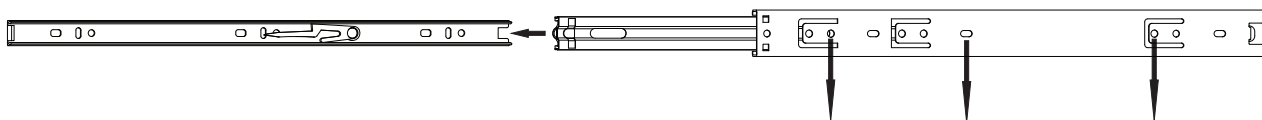
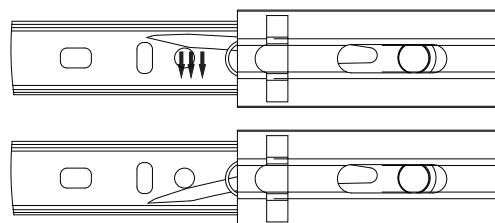

Fixar as corrediças nessas furações

Fijar las diapositivas de estos agujeros



Vídeo: Instalar e regular Dobradiças

Vídeo: Instale y ajuste las bisagras

Vídeo: Install and adjust hinges

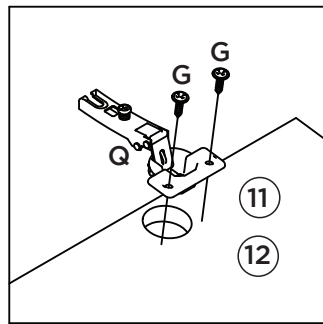

Fixação da dobradiça (Q).

La fijación de la bisagra (Q).

Hinge fixing (Q).

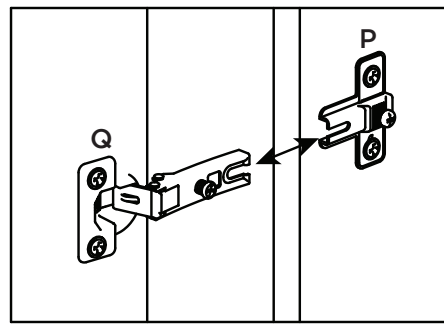

Encaixe da dobradiça (Q) com o calço (P).

Fije la bisagra (Q) con cuña (P).

Hinge fitting (Q) with shim (P).

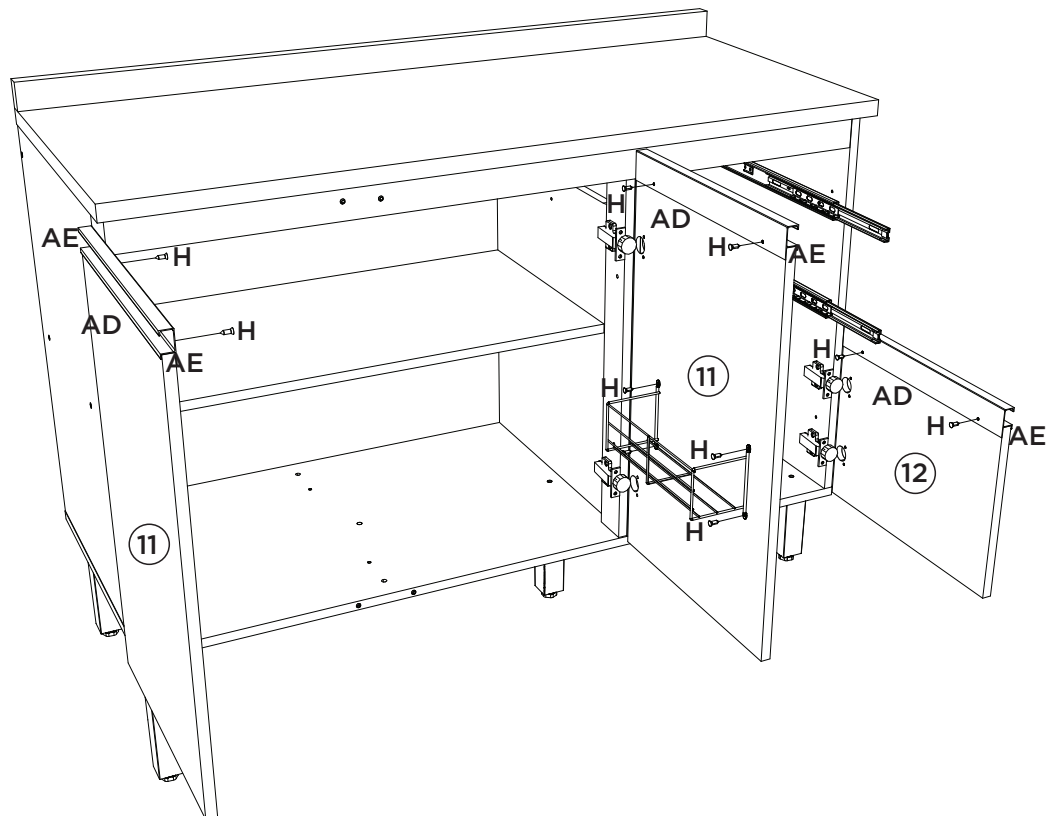
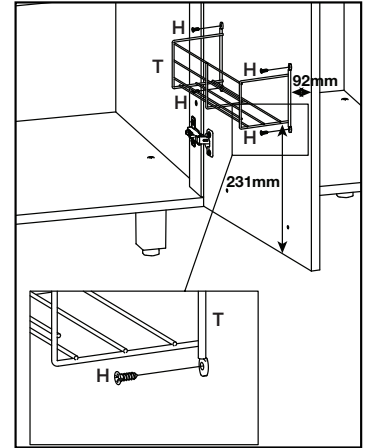
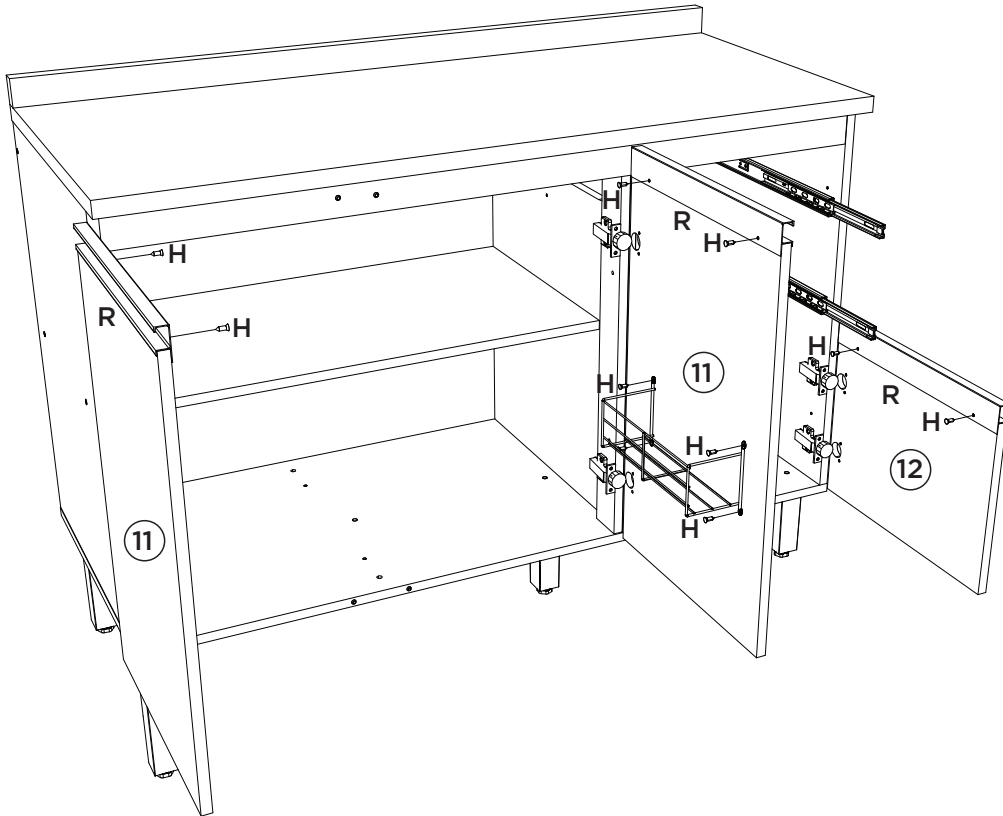

Somente para (C66-139)

Solo para (C66-139)

Only for (C66-139)

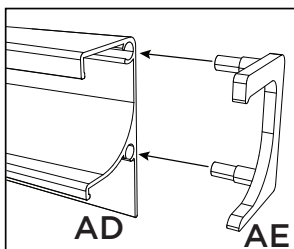

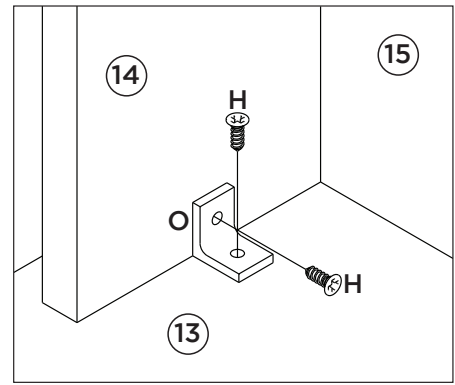
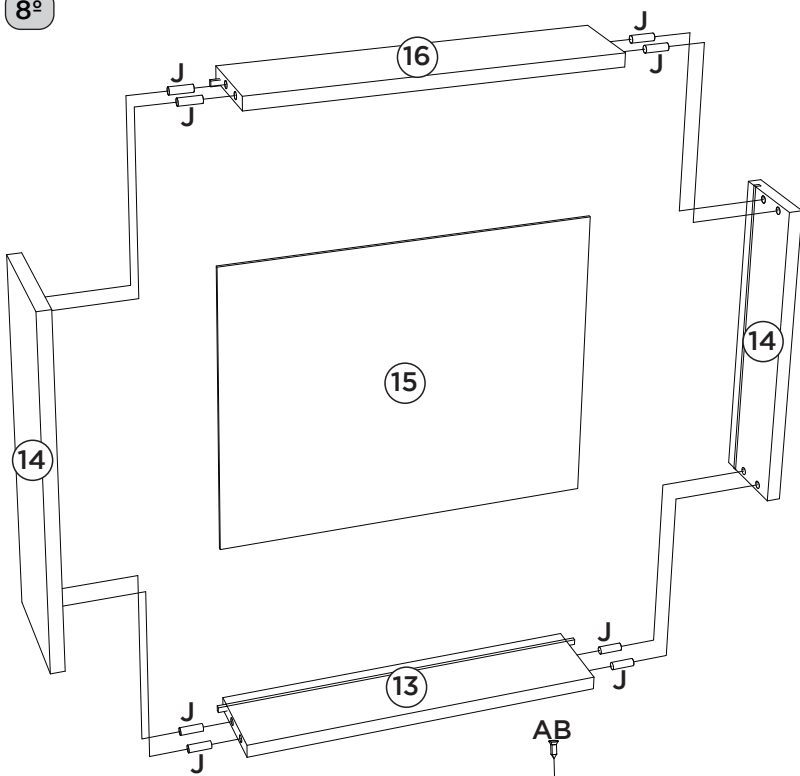

Somente para (C66-139)

Solo para (C66-139)

Only for (C66-139)

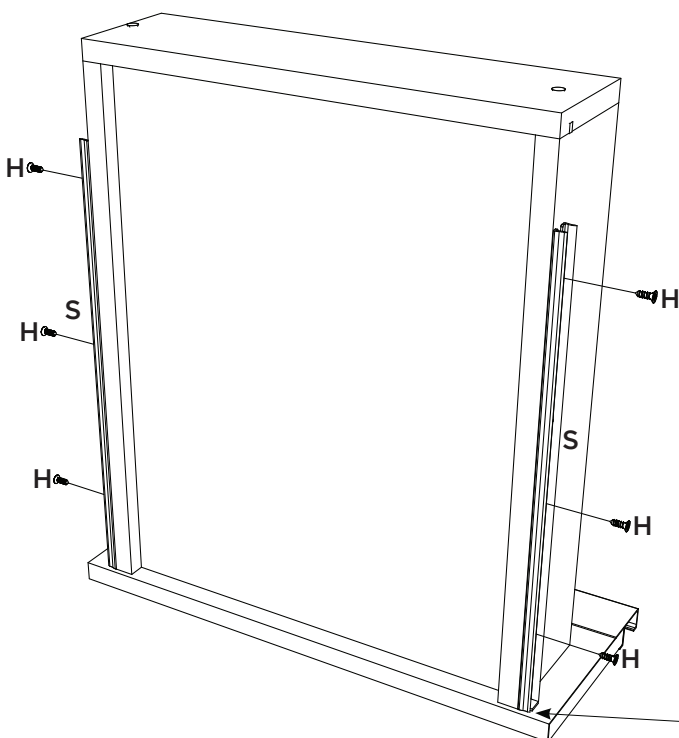
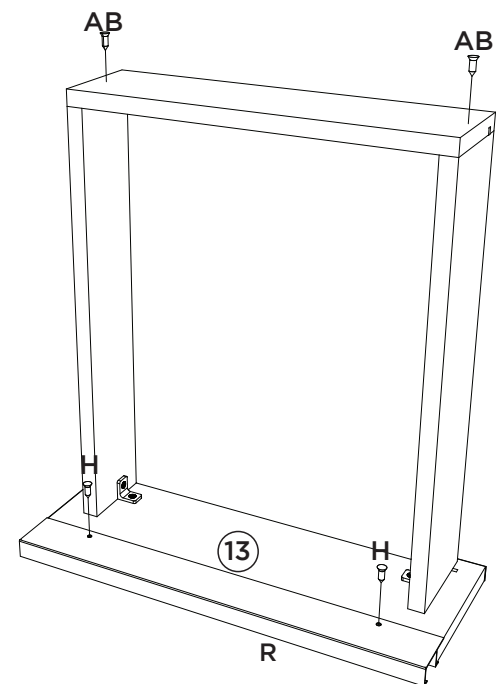
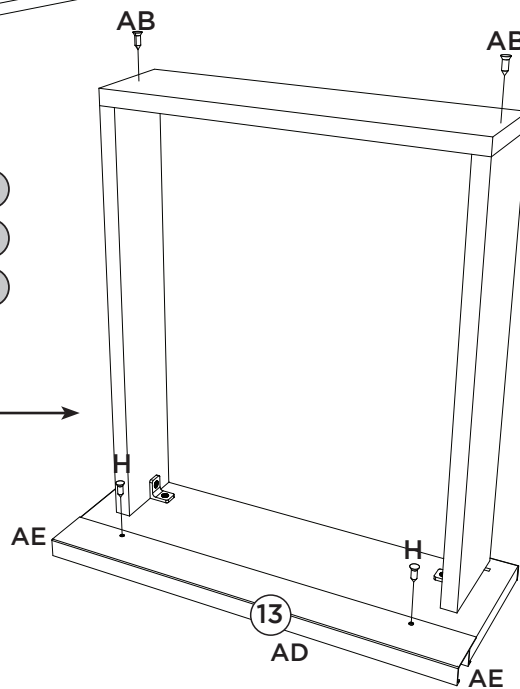
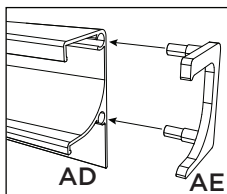

A corredeira (S) deverá ser alinhada com a parte de baixo do lado de gaveta (14).

La carcasa (S) será alineada con la parte de por el lado del cajón (14).

The slide (S) should be aligned with the underside of the drawer side (14).











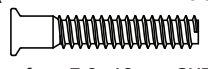
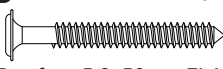



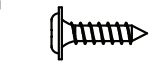

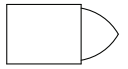

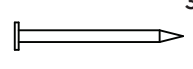
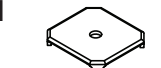
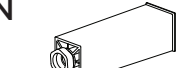

Deixar 3mm de distância da frente de gaveta.

Deje una separación de 3mm del frente del cajón.

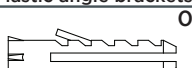
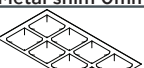
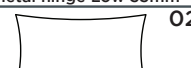
Leave 3mm away from the front of the drawer.

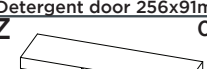
Item	Caixa Caja Box	Qty Ctd Qty	Descrição Descripción Description	Medidas (mm) Dimensions (mm) Size (measurements) (mm)
01	1/1	01	Base Base Base	1200x490x15
02	1/1	01	Lateral esquerda Lateral izquierda Left side	660x490x15
03	1/1	01	Divisão División Division	600x490x15
04	1/1	01	Prateleira Estante Shelf	783x400x15
05	1/1	01	Travessa frontal Travesaño frontal Front crossbar	1168x60x15
06	1/1	01	Travessa traseira Travesaño trasero Rear bumper	1168x60x15
07	1/1	01	Lateral direita Lateral derecha Right side	660x490x15
08	1/1	01	Pilastra da Porta Pilastra Puerta Pilaster door	599x60x15
09	1/1	01	Fundo menor Fondo menor Minor fund	683x389x3
10	1/1	02	Fundo Fondo Bottom	802x341x3
11	1/1	02	Porta Puerta Door	625x396x15
11	1/1	02	Porta Puerta Door (Somente para C66-139)	629x396x15
12	1/1	01	Porta menor Puerta menor Smaller door	396x290x15
12	1/1	01	Porta menor Puerta menor Smaller door (Somente para C66-139)	396x294x15
13	1/1	02	Frente de gaveta Frente de cajón Front of drawer	396x136x15
13	1/1	02	Frente de gaveta Frente de cajón Front of drawe (Somente pra C66-139)	396x140x15
14	1/1	04	Lado de Gaveta menor Lado del cajón menor Smallest Drawer Side	400x90x15
15	1/1	02	Fundo de gaveta Fondo de cajón Bottom of drawer	411x326x3
16	1/1	02	Ripa de trás Malla detrás Rear lath	345x90x15

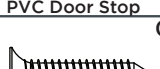
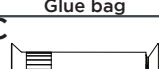
Ferragens | Herrajes | Hardware

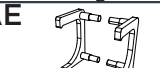
A  Parafuso 7,0x40mm CHT. Tornillo 7,0x40mm CHT. Screw 7,0x40mm CHT.	B  Parafuso 5,0x50mm FLA. Tornillo 5,0x50mm FLA. Screw 5,0x50mm FLA.	C  Parafuso 4,5x50mm CHT. Tornillo 4,5x50mm CHT. Screw 4,5x50mm CHT.	D  Parafuso 4,0x25mm CHT. Tornillo 4,0x25mm CHT. Screw 4,0x25mm CHT.	E  Parafuso 3,5x40mm CHT. Tornillo 3,5x40mm CHT. Screw 3,5x40mm CHT.	F  Divisor talheres 398x313mm Divisor cubiertos 398x313mm Cutlery divider 398x313mm
G  Parafuso 3,5x14mm FLA. Tornillo 3,5x14mm FLA. Screw 3,5x14mm FLA.	H  Parafuso 3,5x12mm CHT. Tornillo 3,5x12mm CHT. Screw 3,5x12mm CHT.	I  Giz de correção Tiza de corrección Chalk of correction	J  Cavilha 8x25mm Cinta 8x25mm Dowel 8x25mm	K  Etiqueta resinada Henn Etiqueta resinada Henn Henn resin label	L  Prego 10x10mm Clavo 10x10mm Nail 10x10mm
M  Fixador de fundos Fijador de fondos Bottom fixer	N  Pé 145mm x 42mm Pie 145mm x 42mm Foot 145mm x 42mm	O  Cantoneira plástica Cantонера plástica Plastic angle brackets	P  Calço metal médio 0mm Calzado metálico medio 0mm Metal shim 0mm	Q  Dobradiça metal Baixa 35mm Bisagra metálica Baja 35mm Metal hinge Low 35mm	R  Puxador MOV 396mm Tirador MOV 396mm MOV 396mm Handle
S  Corrediza telescópica Diapositivas telescópicas Telescopic slides	T  Porta detergente 256x91mm Puerta detergente 256x91mm Detergent door 256x91mm	U  Bucha plástica 8mm Bucha de plástico 8mm 8mm plastic bushing	V  Batente PVC para Porta Parada de PVC para Puerta PVC Door Stop	W  Sachê de cola Bolsa de pegamento Glue bag	X  Adesivo tapa parafuso 17mm Adhesivo tapón de tornillo 17mm Bolt cover adhesive 17mm
Y  Suporte de fixação Soporte de fijación Mounting bracket	Z  Proteção para cantoneira Ángulo de protección Protection angle	AA  Adesivo tapa parafuso 10mm Adhesivo tapón de tornillo 10mm Bolt cover adhesive 10mm	AB  Parafuso 3,0x30mm CHT. Tornillo 3,0x30mm CHT. Screw 3,0x30mm CHT.	AC  Parafuso União 30mm Tornillo Unión 30mm Union Screw 30mm	AD  Puxador MOV4083 - 392mm Tirador MOV4083 - 392mm MOV4083 - 392mm Handle
AE  Kit Ponteira Plástica MOV4083 Kit de punta de plástico MOV4083 Plastic Tip Kit MOV4083					

Somente para (C66-139)

Solo para (C66-139)

Only for (C66-139)

O parafuso (AC) deve ser usada somente quando este módulo for acoplado a outro módulo componível Henn.

El tornillo (AC) se debe utilizar sólo cuando el módulo está conectado a otro módulo componible Henn.

The screw (AC) should be used only when this module is attached to another Henn modular module.

RECOMENDAÇÃO

Para fixar o móvel na parede usar o suporte de fixação (Y), o parafuso 3,5x14mm FLA (G), a Bucha 8mm (U) e o parafuso 5,0x50mm FLA (B).

RECOMENDACIÓN

Para conectar el móvil a la pared con el soporte (Y), tornillo 3,5 x14mm FLA (G), el casquillo de 8 mm (U) y el 5,0 x50mm tornillo FLA (B).

RECOMMENDATION

To fix the furniture to the wall use the mounting bracket (Y), the 3.5x14mm FLA (G) screw, the 8mm bushing (U) and the 5.0x50mm FLA (B).

Torre Quente 2 Fornos 715mm Connect | Torre caliente 2 Hornos 715mm Connect | Hot Tower 2 Ovens 715mm Connect

Referência/Cor

- c C69-35 - Duna/Cristal
- c C69-42 - Fendi
- c C69-139 - Off White

Requisitos para montagem
Requisitos para la montaje
Assembly Requirements

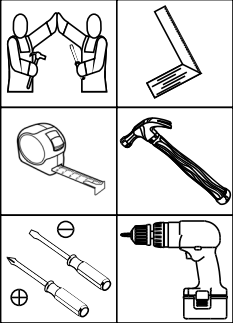

Imagens meramente ilustrativas, não acompanha o produto.
Imágenes ilustrativas, no incluidas con el producto.
Illustrative images, not included with the product.

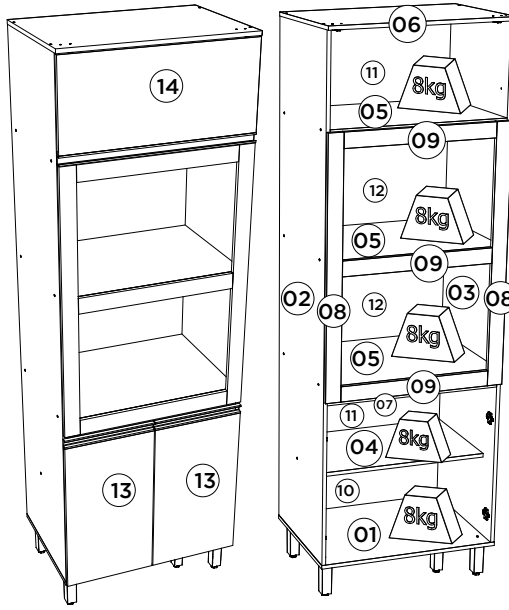

Pesos máximos recomendados com carga distribuída
Peso máximo recomendado con la carga distribuida
Recommended maximum weight with distributed load.

Lista de Peças | Lista de piezas | List of parts

Item	Caixa Caja Box	Qtd Ctd Qty	Descrição Descripción Description	Medidas (mm) Dimensions (mm) Size (measurements) (mm)
01	2/2	01	Base Base Base	715x490x15
02	1/2	01	Lateral esquerda Lateral izquierda Left side	2030x490x15
03	1/2	01	Lateral direita Lateral derecha Right side	2030x490x15
04	1/2	01	Prateleira Inferior Estante inferior Bottom Shelf	683x400x15
05	1/2 e 2/2	03	Prateleira maior Estante mayor Largest shelf	683x490x15
06	2/2	01	Tampo Tapa Top	715x505x15
07	1/2	01	Travessa inferior frontal Travesaño inferior frontal Front lower crossbar	683x65x15
08	1/2	02	Travessa lateral Travesaño lateral Lateral crossbar	1012x60x15
09	1/2	03	Travessa frontal Travesaño frontal Front crossbar	589x60x15
10	1/2	01	Fundo inferior Fondo inferior Bottom background	707x341x3
11	1/2	02	Fundo Fondo Bottom	707x376x3
12	2/2	02	Fundo central Fondo central Central fund	707x479x3
13	1/2	02	Porta Puerta Door	625x354x15
13	1/2	02	Porta Puerta Door (Somnete para C69-139)	629x354x15
14	1/2	01	Porta basculante Puerta basculante Swing door	710x327x15
14	1/2	01	Porta basculante Puerta basculante Swing door (Somnete para C69-139)	711x331x15

AVISO
Para limpeza de seu móvel, use uma flanela seca ou umedecida, e não utilize produtos químicos que possam danificar seu produto.

SISTEMA DE MONTAGEM
O sistema de montagem dos produtos, funciona de acordo com a ordem crescente dos números indicados no desenho. Ex: 01, 02, 03, 04... até a conclusão da montagem.

ASSISTÊNCIA TÉCNICA
Para solicitação de Assistência Técnica você consumidor deverá entrar em contato com o Lojista o qual você realizou a compra deste produto e solicitar a assistência técnica das peças avariadas. A garantia abrange todas as peças, partes e componentes que eventualmente venham apresentar defeito de fabricação no prazo de 03 (três) meses, contando a partir da entrega do produto ao consumidor, mediante nota fiscal de compra. Se houver qualquer alteração na estrutura do produto ou ocorrer defeito por negligência do montador/consumidor em relação a instrução de montagem e manuseio, não será fornecida assistência técnica gratuita.

ADVERTENCIA
Para limpieza de su móvil, use una flanela seca o húmeda, y no utilice productos químicos que puedan dañar su producto.

SISTEMA DE MONTAJE
El sistema de montaje de los productos funciona de acuerdo con el orden creciente de los números indicados en el dibujo. Ej.: 01, 02, 03, 04... hasta la conclusión del montaje.

ASSISTENCIA TÉCNICA
Para solicitar Asistencia Técnica, el consumidor debe comunicarse con el Comercio que usted realizó la compra de este producto y solicita asistencia técnica para las partes dañadas. La garantía cubre todas las partes, piezas y componentes que eventualmente puedan presentar defecto de fabricación en el plazo de 03 (tres) meses, contados a partir de la entrega del producto al consumidor, mediante factura de compra. Si se produce algún cambio en la estructura del producto o se produce un defecto por negligencia del montador/consumidor en relación con las instrucciones de montaje y manipulación, no se prestará asistencia técnica gratuita.

NOTICE
To clean your furniture, use a dry or wet cloth, and do not use chemicals that may damage your product.

ASSEMBLY SYSTEM
The products' assembly system works according to the increasing order of the indicated numbers. For example: 01, 02, 03, 04 ... to the end of the assembly.

TECHNICAL ASSISTANCE
To request Technical Assistance, the consumer must contact the retailer from whom you purchased this product and request technical assistance for the damaged parts. The warranty covers all parts, parts and components that may eventually present a manufacturing defect within a period of 03 (three) months, counting from the delivery of the product to the consumer, by means of a purchase invoice. If there is any change in the structure of the product or defect occurs due to negligence of the assembler/consumer in relation to the assembly and handling instruction, free technical assistance will not be provided.

Ferragens | Herrajes | Hardware

A 04x Parafuso 7,0x40mm CHT. Tornillo 7,0x40mm CHT. Screw 7,0x40mm CHT.	B 01x Parafuso 5,0x50mm FLA. Tornillo 5,0x50mm FLA. Screw 5,0x50mm FLA.	C 04x Parafuso União 30mm Tornillo Unión 30mm Union Screw 30mm
D 22x Parafuso 3,5x40mm CHT. Tornillo 3,5x40mm CHT. Screw 3,5x40mm CHT.	E 02x Parafuso 4,0x25mm CHT. Tornillo 4,0x25mm CHT. Screw 4,0x25mm CHT.	F 40x Parafuso 3,5x14mm FLA. Tornillo 3,5x14mm FLA. Screw 3,5x14mm FLA.
G 15x Parafuso 3,5x12mm CHT. Tornillo 3,5x12mm CHT. Screw 3,5x12mm CHT.	H 28x Cavilha 8x25mm Cinta 8x25mm Dowel 8x25mm	I 04x Parafuso União 15mm Tornillo Unión 15mm Union Screw 15mm
J 74x Prego 10x10mm Clavo 10x10mm Nail 10x10mm	K 24x Fixador de fundos Fijador de fondos Bottom fixer	L 08x Conector de Montagem Conector de montaje Mounting Connector
M 04x Calço metal médio 0mm Calzón de metal medio 0mm Shim metal middle 0mm	N 04x Dobradiça metal 35mm Colo Baixo Bisagra de metal 35mm Colo Bajo Metal hinge 35mm Colo Low	O 02x Calço metal Super Alto 8mm Calzón metálico Super Alto 8mm Super 8mm metal chock
P 02x Dobradiça metal 35mm Alta Bisagras metálicas 35mm Alta Metal hinge 35mm High	Q 04x Suporte metal Soporte metálico Metal support	R 02x Puxador MOV 354mm Tirador MOV 354mm MOV 354mm Handle
S 01x Puxador MOV 710mm Tirador MOV 710mm MOV 710mm Handle	T 01x Kit Pistão a Gás 60N Kit Pistón a Gas 60N 60N Gas Piston Kit	U 04x Pé 145mm x 42mm Pie 145mm x 42mm Foot 145mm x 42mm
V 06x Batente PVC para Porta Parada de PVC para Puerta PVC Door Stop	W 01x Suporte de fixação Soporte de fijación Mounting bracket	X 01x Proteção para cantoneira Ángulo de protección Protection angle
Y 02x Giz de correção Tiza de corrección Chalk of correction	Z 01x Bucha plástica 8mm Bucha de plástico 8mm 8mm plastic bushing	AA 01x Etiqueta resinada Henn Etiqueta resinada Henn Henn resin label
AB 22x Adesivo tapa parafuso 10mm Adhesivo tapón de tornillo 10mm Bolt cover adhesive 10mm	AC 04x Adesivo tapa parafuso 17mm Adhesivo tapón de tornillo 17mm Bolt cover adhesive 17mm	AD 01x Sachê de cola Bolsa de pegamento Glue bag

G 15x Parafuso 3,5x12mm CHT. Tornillo 3,5x12mm CHT. Screw 3,5x12mm CHT.	H 28x Cavilha 8x25mm Cinta 8x25mm Dowel 8x25mm	I 04x Parafuso União 15mm Tornillo Unión 15mm Union Screw 15mm	J 74x Prego 10x10mm Clavo 10x10mm Nail 10x10mm	K 24x Fixador de fundos Fijador de fondos Bottom fixer	L 08x Conector de Montagem Conector de montaje Mounting Connector
M 04x Calço metal médio 0mm Calzón de metal medio 0mm Shim metal middle 0mm	N 04x Dobradiça metal 35mm Colo Baixo Bisagra de metal 35mm Colo Bajo Metal hinge 35mm Colo Low	O 02x Calço metal Super Alto 8mm Calzón metálico Super Alto 8mm Super 8mm metal chock	P 02x Dobradiça metal 35mm Alta Bisagras metálicas 35mm Alta Metal hinge 35mm High	Q 04x Suporte metal Soporte metálico Metal support	R 02x Puxador MOV 354mm Tirador MOV 354mm MOV 354mm Handle
S 01x Puxador MOV 710mm Tirador MOV 710mm MOV 710mm Handle	T 01x Kit Pistão a Gás 60N Kit Pistón a Gas 60N 60N Gas Piston Kit	U 04x Pé 145mm x 42mm Pie 145mm x 42mm Foot 145mm x 42mm	V 06x Batente PVC para Porta Parada de PVC para Puerta PVC Door Stop	W 01x Suporte de fixação Soporte de fijación Mounting bracket	X 01x Proteção para cantoneira Ángulo de protección Protection angle
Y 02x Giz de correção Tiza de corrección Chalk of correction	Z 01x Bucha plástica 8mm Bucha de plástico 8mm 8mm plastic bushing	AA 01x Etiqueta resinada Henn Etiqueta resinada Henn Henn resin label	AB 22x Adesivo tapa parafuso 10mm Adhesivo tapón de tornillo 10mm Bolt cover adhesive 10mm	AC 04x Adesivo tapa parafuso 17mm Adhesivo tapón de tornillo 17mm Bolt cover adhesive 17mm	AD 01x Sachê de cola Bolsa de pegamento Glue bag

AG
01x
Kit Ponteira Plástica MOV4083
Kit de punta de plástico MOV4083
Plastic Tip Kit MOV4083

- Somente para (C69-139)
- Solo para (C69-139)
- Only for (C69-139)

O parafuso (C) deve ser usada somente quando este módulo for acoplado a outro módulo componível Henn.

El tornillo (C) se debe utilizar sólo cuando el módulo está conectado a otro módulo componible Henn.

The screw (C) should be used only when this module is attached to another Henn modular module.

RECOMENDAÇÃO
Para fixar o móvel na parede usar o suporte de fixação (W), o parafuso 3,5x14mm FLA (F), a Bucha 8mm (Z) e o parafuso 5,0x50mm FLA (B).

RECOMENDACIÓN
Para conectar el móvil a la pared con el soporte (W), tornillo 3,5 x14mm FLA (F), el casquillo de 8 mm (Z) y el 5,0 x50mm tornillo FLA (B).

RECOMMENDATION
To fix the furniture to the wall use the fixing bracket (W), the 3.5x14mm FLA (F) screw, the 8mm bushing (Z) and the 5.0x50mm FLA screw (B).

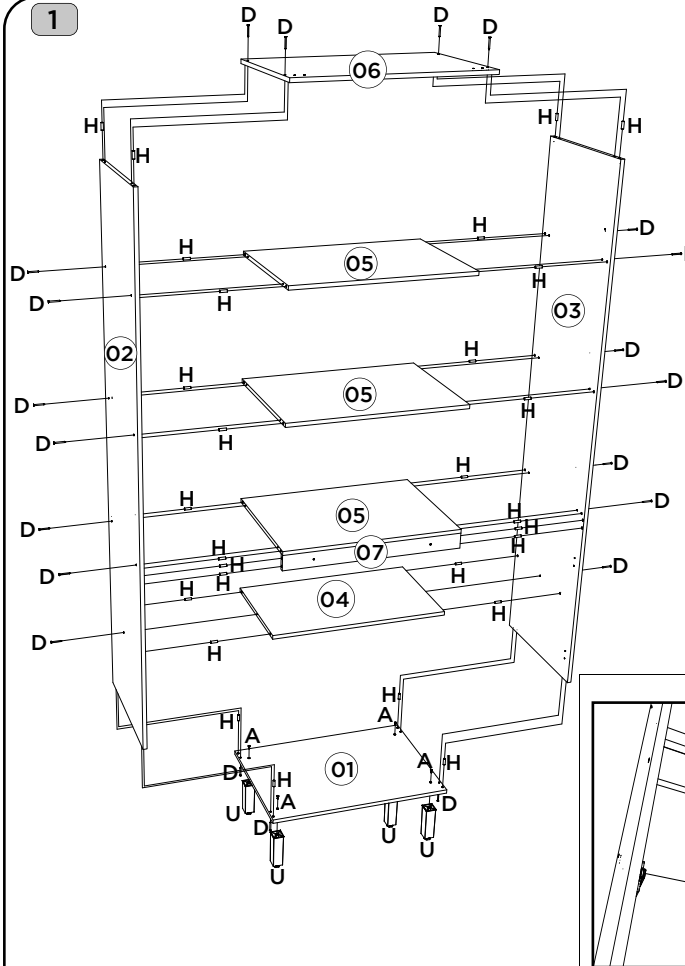

Utilizar o sachê de cola (AD) em todas as cavilhas (H) do produto.

Con el pegamento sobre (AD) en todos los pernos (H) producto.

Use the glue sachet (AD) on all the pegs (H) of the product.

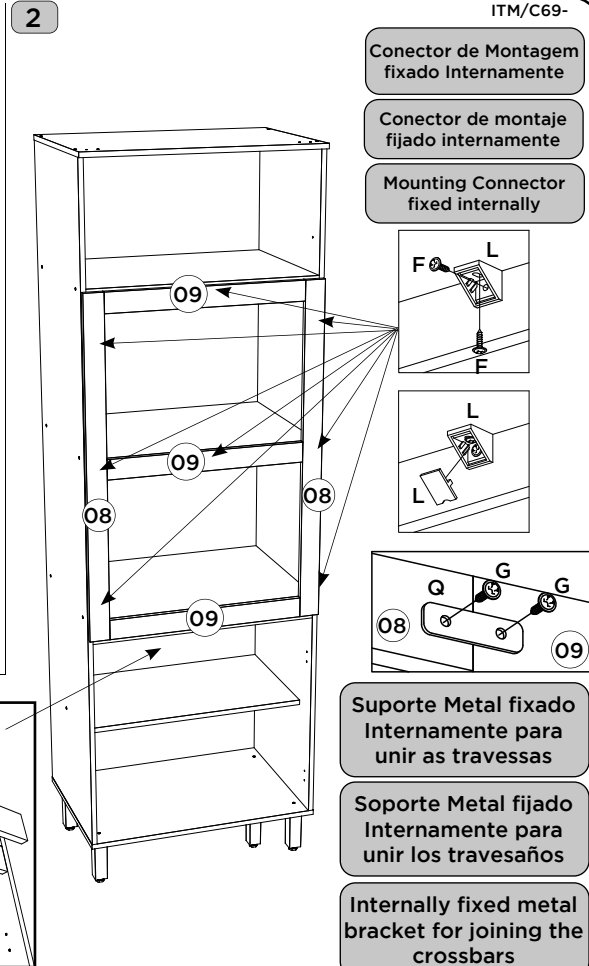

Conector de Montagem fixado Internamente

Conector de montaje fijado internamente

Mounting Connector fixed internally

Soporte Metal fixado Internamente para unir as travessas

Soporte Metal fijado Internamente para unir los travesaños

Internally fixed metal bracket for joining the crossbars

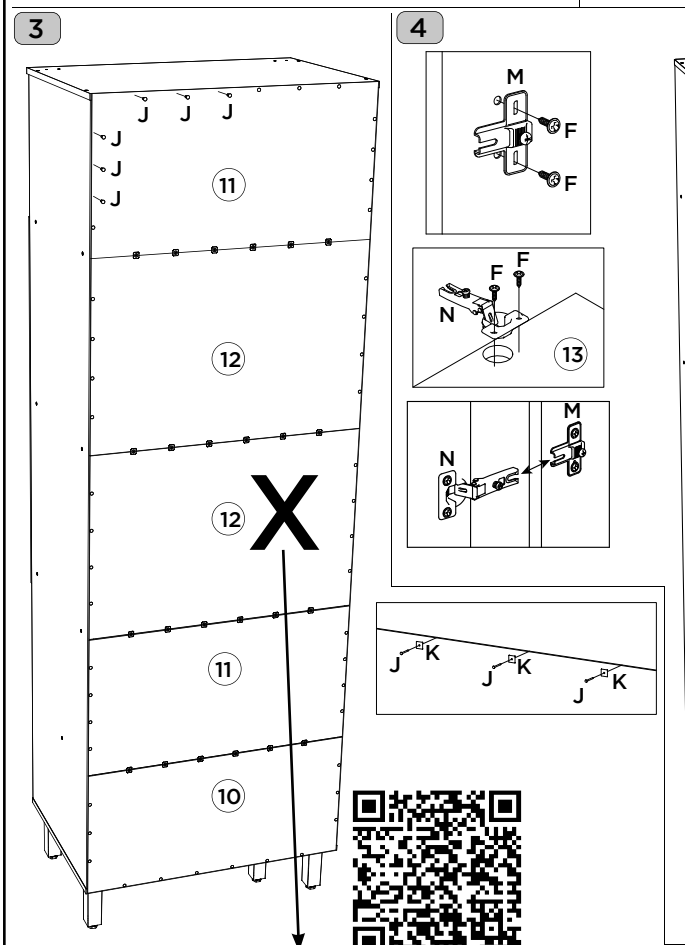

ATENÇÃO: Por questão de segurança, recomendamos a não utilização do Fundo (12) caso o espaço seja utilizado por forno elétrico ou forno embutido, dessa forma, haverá melhor propagação do calor, evitando danos em seu móvel.

ADVERTENCIA: Por razones de seguridad, se recomienda no utilizar el Fondo (12) si el espacio es utilizado por horno eléctrico o una función de horno, de esta manera no será mejor propagación del calor, evitando el daño a su móvil.

ATTENTION: For safety reasons, we recommend not using the Wall (12) if the space is used by an electric oven or built-in oven, in this way, there will be better propagation of the heat, avoiding damage to your furniture.

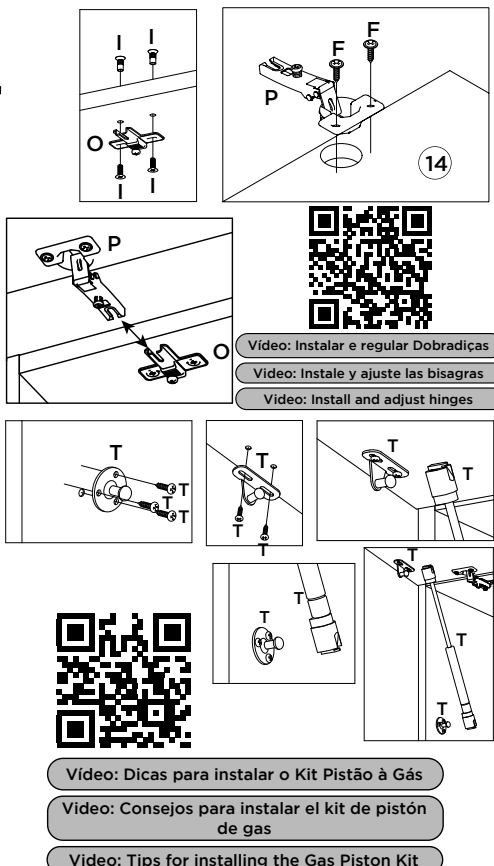
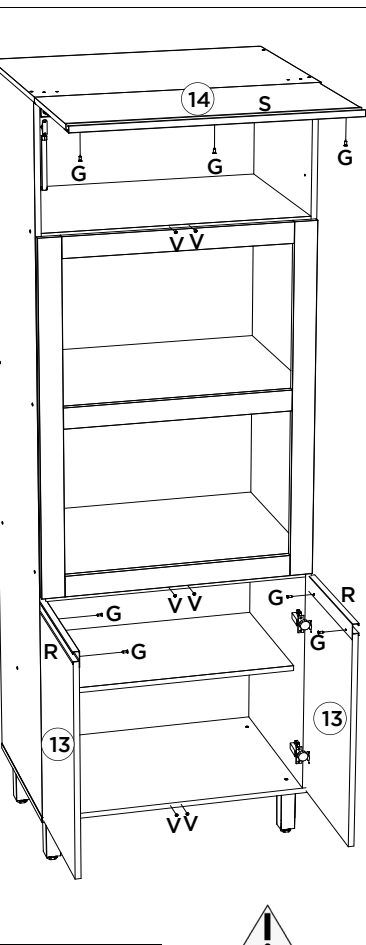

Vídeo: Instalar e regular Dobradiças

Vídeo: Instale y ajuste las bisagras

Vídeo: Install and adjust hinges

Vídeo: Dicas para instalar o Kit Pistão à Gás

Vídeo: Consejos para instalar el kit de pistón de gas

Vídeo: Tips for installing the Gas Piston Kit

Somente para (C69-139)

Solo para (C69-139)

Only for (C69-139)

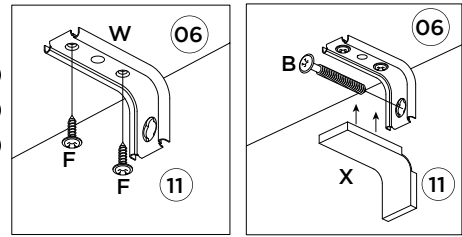
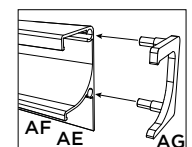

HENNInd. e Com. de Móveis Henn
Mondai - SC - Brasil

☎ +55 49 3674.3500

📧 @moveishenn
www.henn.com.br**INSTRUÇÕES DE MONTAGEM**INSTRUCCIONES DE MONTAJE
ASSEMBLY INSTRUCTIONS**Paneleiro 2Portas 350mm Connect**
Paneleiro 2Puertas 350mm Connect
Paneling 2Doors 350mm Connect**Referência/Cor**

c C72-35 - Duna/Cristal

c C72-42 - Fendi

c C72-139 - Off White

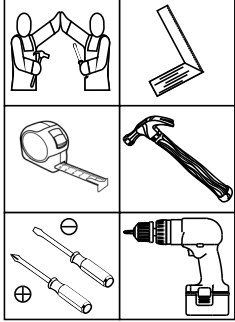
Requisitos para montagem**Requisitos para la montaje****Assembly Requirements**Imagens meramente ilustrativas
Imágenes meramente ilustrativas
Images for illustration only**Lista de Peças | Lista de piezas | List of parts**

Item	Caixa Caja Box	Qtd Ctd Qty	Descrição Descripción Description	Medidas (mm) Dimensions (mm) Size (measurements) (mm)
01	1/1	01	Base Base Base	350x295x15
02	1/1	01	Lateral esquerda Lateral izquierda Left side	2030x295x15
03	1/1	01	Lateral direita Lateral derecha Right side	2030x295x15
04	1/1	04	Prateleira Estante Shelf	318x250x15
05	1/1	01	Prateleira maior Estante mayor Largest shelf	318x295x15
06	1/1	01	Travessa frontal Travesaño frontal Front crossbar	318x60x15
07	1/1	01	Tampo Tapa Top	350x310x15
08	1/1	01	Fundo Superior Fondo superior Superior background	990x342x3
09	1/1	04	Fundo Inferior Fondo inferior Bottom background	1063x342x3
10	1/1	01	Porta maior Puerta mayor Larger door	1339x346x15
10	1/1	01	Porta maior Puerta mayor Larger door	1343x346x15
11	1/1	01	Porta Puerta Door	625x346x15
11	1/1	01	Porta Puerta Door	629x346x15

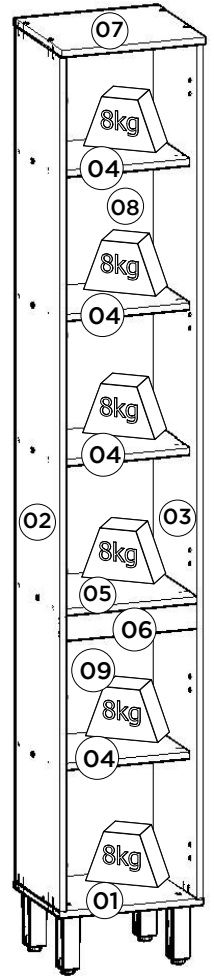
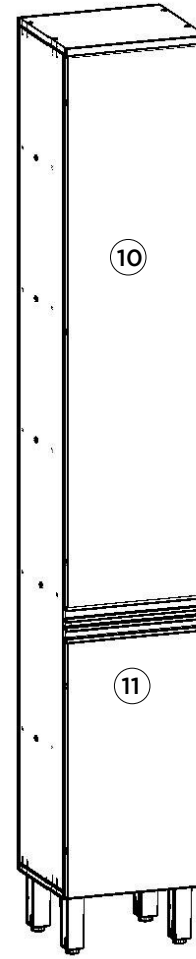

Pesos máximos recomendados com carga distribuída
Peso máximo recomendado con la carga distribuída
Recommended maximum weight with distributed load.

Ferragens | Herrajes | Hardware

A	04x	B	01x	C	04x	D	18x	E	01x	F	22x	G	04x	H	32x
	Parafuso 7,0x40mm CHT. Tornillo 7,0x40mm CHT. Screw 7,0x40mm CHT.		Parafuso 5,0x50mm FLA. Tornillo 5,0x50mm FLA. Screw 5,0x50mm FLA.		Parafuso União 30mm Tornillo Unión 30mm Union Screw 30mm		Parafuso 3,5x40mm CHT. Tornillo 3,5x40mm CHT. Screw 3,5x40mm CHT.		Etiqueta resinada Henn Etiqueta resinada Henn Henn resin label		Parafuso 3,5x14mm FLA. Tornillo 3,5x14mm FLA. Screw 3,5x14mm FLA.		Parafuso 3,5x12mm CHT. Tornillo 3,5x12mm CHT. Screw 3,5x12mm CHT.		Cavilha 8x25mm Cinta 8x25mm Dowel 8x25mm
I	01x	J	60x	K	03x	L	01x	M	05x	N	05x	O	02x	P	01x
	Sachê de cola Bolsa de pegamento Glue bag		Prego 10x10mm Clavo 10x10mm Nail 10x10mm		Fixador de fundos Fijador de fondos Bottom fixer		Proteção para cantoneira Ángulo de protección Protection angle		Calço metal médio 0mm Calzón de metal medio 0mm Shim metal middle 0mm		Dobradiça metal 35mm Colo Baixo Bisagra de metal 35mm Colo Bajo Metal hinge 35mm Colo Low		Giz de correção Tiza de corrección Chalk of correction		Bucha plástica 8mm Bucha de plástico 8mm 8mm plastic bushing
Q	01x	R	02x	S	14x	T	04x	U	04x	V	08x	W	02x	X	01x
	Suporte de fixação Soporte de fijación Mounting bracket		Puxador MOV 346mm Tirador MOV 346mm MOV 346mm Handle		Adesivo tapa parafuso 10mm Adhesivo tapón de tornillo 10mm Bolt cover adhesive 10mm		Adesivo tapa parafuso 17mm Adhesivo tapón de tornillo 17mm Bolt cover adhesive 17mm		Pé 145mm x 42mm Pie 145mm x 42mm Foot 145mm x 42mm		Batente PVC para Porta Parada de PVC para Puerta PVC Door Stop		Puxador MOV4083 - 342mm Tirador MOV4083 - 342mm MOV4083 - 342mm Handle		Kit Ponta Plástica MOV4083 Kit de punta de plástico MOV4083 Plastic Tip Kit MOV4083

O parafuso (C) deve ser usada somente quando este módulo for acoplado a outro módulo componível Henn.

El tornillo (C) se debe utilizar sólo cuando el módulo está conectado a otro módulo componible Henn.

The screw (C) should be used only when this module is attached to another Henn modular module.

RECOMENDAÇÃO

Para fixar o móvel na parede usar o suporte de fixação (Q), o parafuso 3,5x14mm FLA (F), a Bucha 8mm (P) e o parafuso 5,0x50mm FLA (B).

RECOMENDACIÓN

Para conectar el móvil a la pared con el soporte (Q), tornillo 3,5 x14mm FLA (F), el casquillo de 8 mm (P) y el 5,0 x50mm tornillo FLA (B).

RECOMMENDATION

To fix the furniture to the wall use the fixing bracket (Q), the 3.5x14mm FLA (F) screw, the 8mm bushing (P) and the 5.0x50mm FLA (B).

Somente para (C72-139)

Solo para (C72-139)

Only for (C72-139)

1º

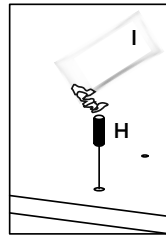
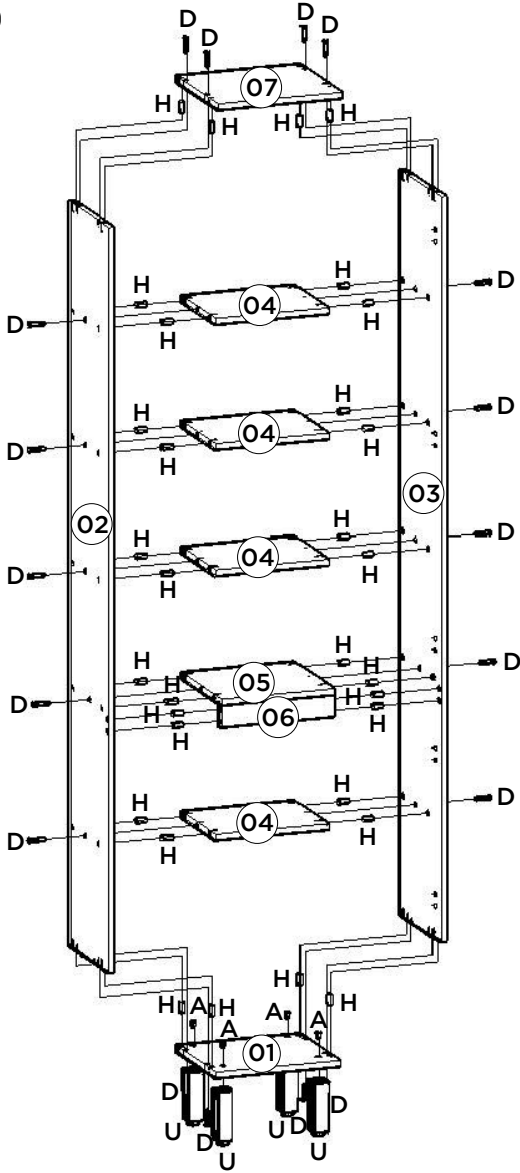

Utilizar o sachê de cola (I) em todas as cavilhas (H) do produto.

Con el pegamento sobre (U) en todos los pernos (H) producto.

Use the glue sachet (U) on all the pegs (H) of the product.

2º

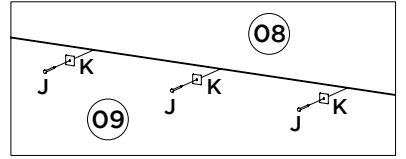
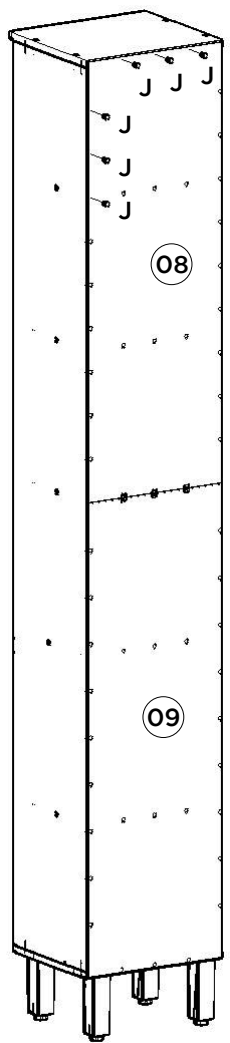

3º

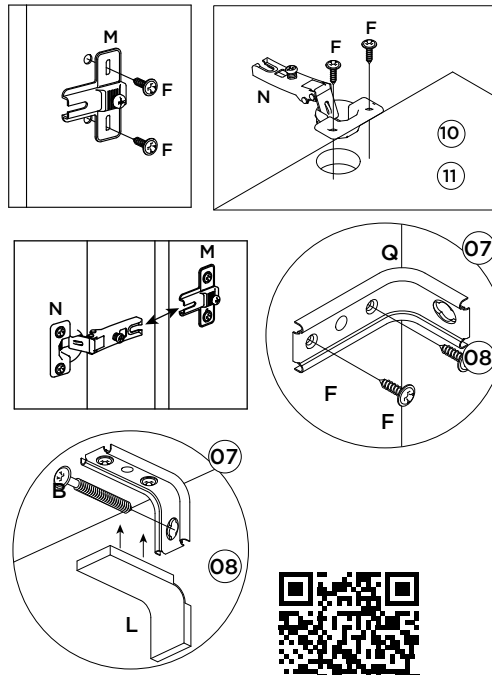
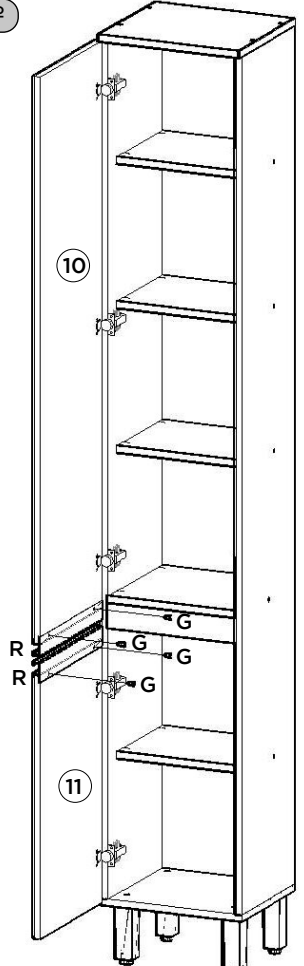

Vídeo: Instalar e regular Dobradiças

Vídeo: Instale y ajuste las bisagras

Vídeo: Install and adjust hinges

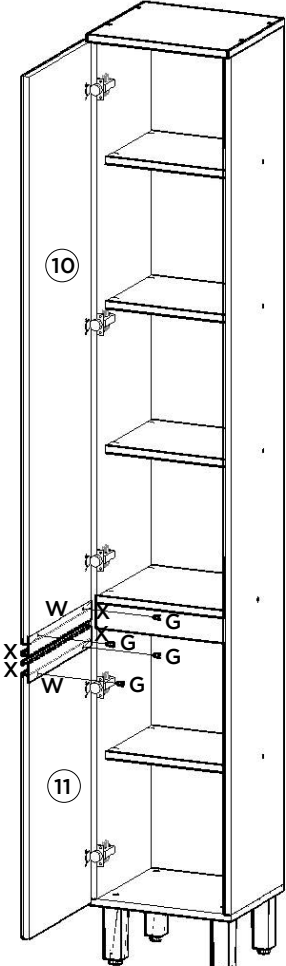

Somente para (C72-139)

Solo para (C72-139)

Only for (C72-139)

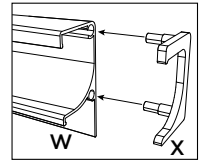

HENNInd. e Com. de Móveis Henn
Mondai - SC - Brasil

☎ +55 49 3674.3500

📧 @moveishenn
www.henn.com.br**INSTRUÇÕES DE MONTAGEM**INSTRUCCIONES DE MONTAJE
ASSEMBLY INSTRUCTIONS**Tampo Cooktop 800mm | Tampo Cooktop 800mm | Cooktop top 800mm**

- C908-23 Duna
- C908-33 Nero
- C908-114 Calcare

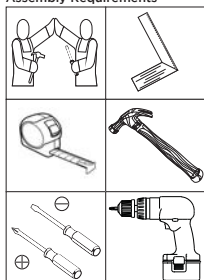
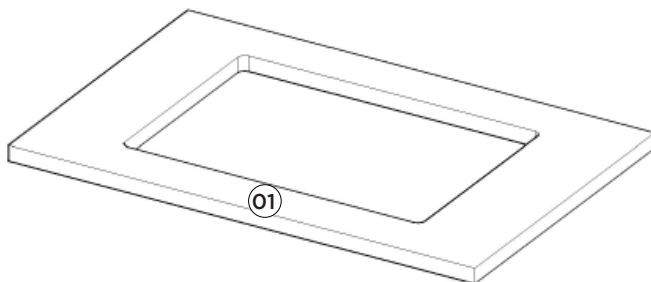
Requisitos para montagem
Requisitor para la montaje
Assembly RequirementsImagens meramente ilustrativas
Imágenes meramente ilustrativas
Images for illustration only**AVISO**

Para limpeza de seu móvel, use uma flanela seca ou umedecida, e não utilize produtos químicos que possam danificar seu produto.

SISTEMA DE MONTAGEM

O sistema de montagem dos produtos, funciona de acordo com a ordem crescente dos números indicados no desenho. Ex: 01, 02, 03, 04... até a conclusão da montagem.

ADVERTENCIA

Para limpieza de su móvil, use una franela seca o húmeda, y no utilice productos químicos que puedan dañar su producto.

SISTEMA DE MONTAJE

El sistema de montaje de los productos funciona de acuerdo con el orden creciente de los números indicados en el dibujo. Ej.: 01, 02, 03, 04... hasta la conclusión del montaje.

NOTICE

To clean your furniture, use a dry or wet cloth, and do not use chemicals that may damage your product.



ASSEMBLY SYSTEM

The products' assembly system works according to the increasing order of the indicated numbers. For example: 01, 02, 03, 04 ... to the end of the assembly.

Lista de Peças | Lista de piezas | List of parts

Item	Caixa Caja Box	Qty Ctd Qty	Descrição Descripción Description	Medidas (mm) Dimensions (mm) Size (measure- ments) (mm)
01	1/1	01	Tampo Tapa Top	800x533x25

Ferragens | Herrajes | Hardware

A		08x	B		04x
Parafuso 3,5x14mm FLA. Tornillo 3,5x14mm FLA. Screw 3,5x14mm FLA.			Cantoneira plástica Cantonera plástica Plastic angle brackets		

 Estas ferragens constam no Pacote do respectivo Balcão.
Estos herrajes constan en el Paquete del respectivo Balcón.
These hardware are included in the Package of the respective Counter.

Esse tampo é opcional e é vendido separadamente

Esta vez es opcional y se vende por separado

This top is optional and is sold separately

Exemplo de como fixar o Tampo Cooktop no produto.

Ejemplo de cómo fijar el Tablero Cooktop en el producto.

Example of how to secure the Cooktop Top to the product.

