

HENN

Ind. e Com. de Móveis Henn
Mondai - SC - Brasil

+55 49 3674.3500

@moveishenn
www.henn.com.br

INSTRUÇÕES DE MONTAGEM

INSTRUCCIONES DE MONTAJE
ASSEMBLY INSTRUCTIONS

Cozinha Completa 7 Peças Cristaleira com Tampo Aurora

c CE733-35 - Duna/Cristal

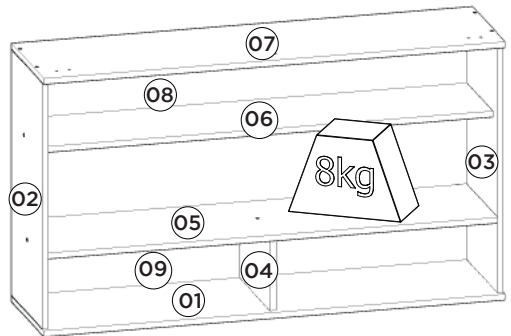
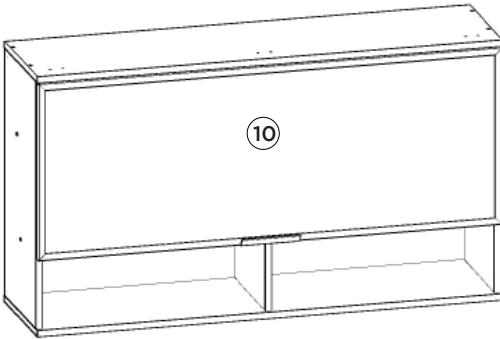

Pesos máximos recomendados com carga distribuída
Peso máximo recomendado con la carga distribuida
Recommended maximum weight with distributed load.

AVISO

Para limpeza de seu móvel, use uma flanela seca ou umedecida, e não utilize produtos químicos que possam danificar seu produto.

SISTEMA DE MONTAGEM

O sistema de montagem dos produtos, funciona de acordo com a ordem crescente dos números indicados no desenho. Ex: 01, 02, 03, 04... até a conclusão da montagem.

ASSISTÊNCIA TÉCNICA

Para solicitação de Assistência Técnica você consumidor deverá entrar em contato com o Lojista o qual você realizou a compra deste produto e solicitar a assistência técnica das peças avariadas. A garantia abrange todas as peças, partes e componentes que eventualmente venham apresentar defeito de fabricação no prazo de 03 (três) meses, contando a partir da entrega do produto ao consumidor, mediante nota fiscal de compra. Se houver qualquer alteração na estrutura do produto ou ocorrer defeito por negligência do montador/consumidor em relação a instrução de montagem e manuseio, não será fornecido assistência técnica gratuita.

ADVERTENCIA

Para limpieza de su móvil, use una flanela seca o húmeda, y no utilice productos químicos que puedan dañar su producto.

SISTEMA DE MONTAJE

El sistema de montaje de los productos funciona de acuerdo con el orden creciente de los números indicados en el dibujo. Ej.: 01, 02, 03, 04... hasta la conclusión del montaje.

ASISTENCIA TÉCNICA

Para solicitar Asistencia Técnica, el consumidor debe comunicarse con el Comercio que usted realizó la compra de este producto y solicita asistencia técnica para las partes dañadas. La garantía cubre todas las partes, piezas y componentes que eventualmente puedan presentar defecto de fabricación en el plazo de 03 (tres) meses, contados a partir de la entrega del producto al consumidor, mediante factura de compra. Si se produce algún cambio en la estructura del producto o se produce un defecto por negligencia del montador/consumidor en relación con las instrucciones de montaje y manipulación, no se prestará asistencia técnica gratuita.

NOTICE

To clean your furniture, use a dry or wet cloth, and do not use chemicals that may damage your product.

ASSEMBLY SYSTEM

The products' assembly system works according to the increasing order of the indicated numbers. For example: 01, 02, 03, 04 ... to the end of the assembly.

TECHNICAL ASSISTANCE

To request Technical Assistance, the consumer must contact the retailer from whom you purchased this product and request technical assistance for the damaged parts. The warranty covers all parts, parts and components that may eventually present a manufacturing defect within a period of 03 (three) months, counting from the delivery of the product to the consumer, by means of a purchase invoice. If there is any change in the structure of the product or defect occurs due to negligence of the assembler/consumer in relation to the assembly and handling instruction, free technical assistance will not be provided.

Requisitos para montagem
Requisitos para la montaje
Assembly Requirements

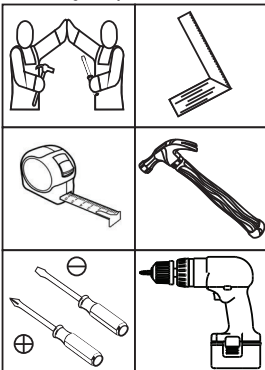

Imagens meramente ilustrativas
Imágenes meramente ilustrativas
Images for illustration only

1º

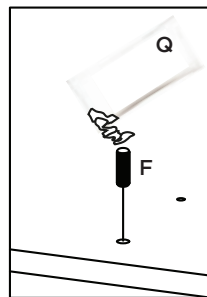
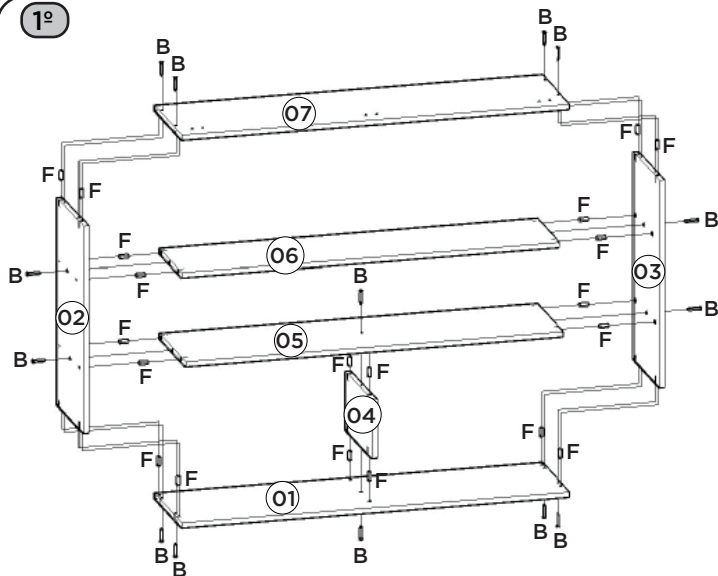

Utilizar o sachê de cola (Q) em todas as cavilhas (F) do produto.

Con el pegamento sobre (Q) en todos los pernos (F) producto.

Use the glue sachet (Q) on all the pegs (F) of the product.

2º

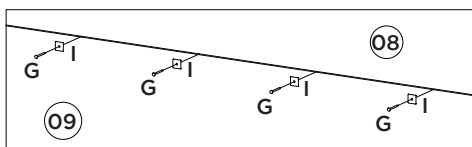
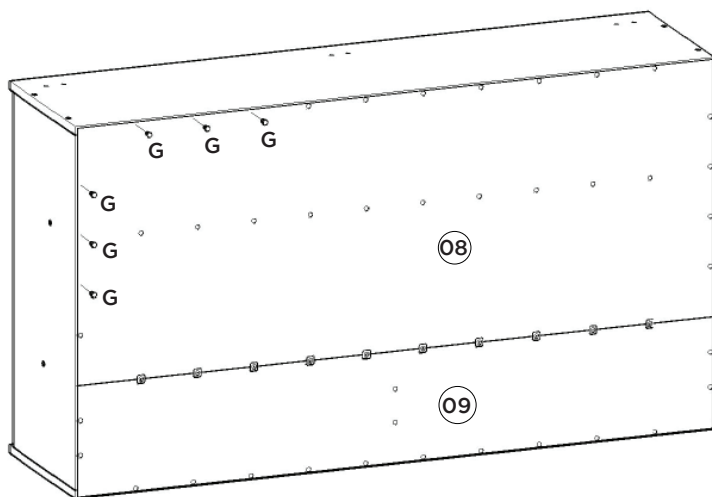

3º Regulagem do pistão sempre o mais distante possível da dobradiça. Ajuste de pistón siempre en la medida de lo posible, la bisagra.

Adjust the piston as far as possible from the hinge.

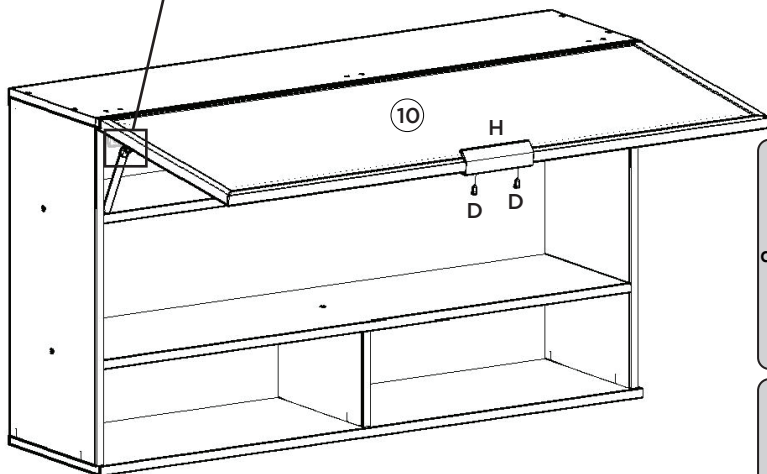

Regulagem do parafuso da dobradiça no máximo para dentro, afastando a porta do tampo, isso apenas nas duas extremidades da porta. Já na dobradiça central da porta o parafuso deverá ficar na regulagem normal (no meio).

Ajuste del tornillo de la bisagra en el máximo hacia dentro, alejando la puerta de la tapa, sólo en los dos extremos de la puerta. En la bisagra central de la puerta, el tornillo deberá quedar en la regulación normal (en el centro).

Adjusting the hinge bolt to maximum inside, pushing the door off the top, this only at both ends of the door. In the central hinge of the door the bolt should be in the normal setting (in the middle).



Video: Instalar e regular Dobradiças

Video: Instale y ajuste las bisagras

Video: Install and adjust hinges

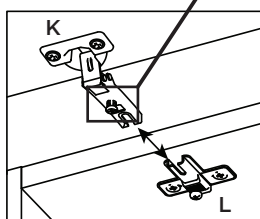
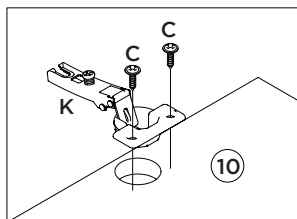
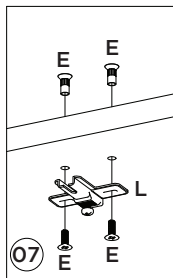

Video: Dicas para instalar o Kit Pistão à Gás





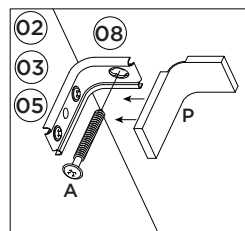
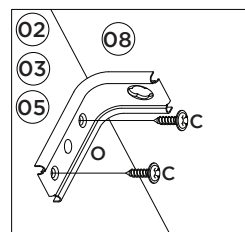
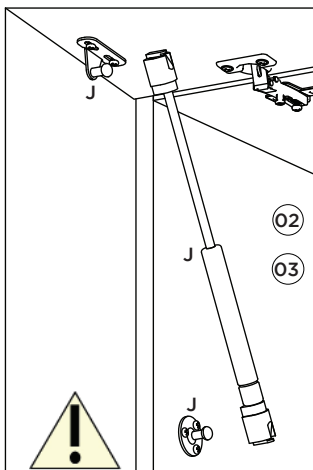
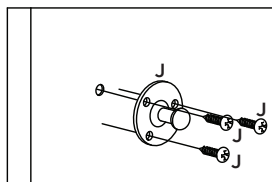
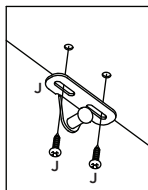





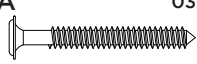





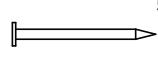

Video: Consejos para instalar el kit de pistón de gas

Video: Tips for installing the Gas Piston Kit

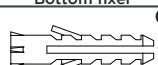

Item	Caixa Caja Box	Qtd Ctd Qty	Descrição Descripción Description	Medidas (mm) Dimensions (mm) Size (measurements) (mm)
01	1/1	01	Base Base Base	1200x310x15
02	1/1	01	Lateral esquerda Lateral izquierda Left side	645x295x15
03	1/1	01	Lateral direita Lateral derecha Right side	645x295x15
04	1/1	01	Divisória Tabique Partition	293x183x15
05	1/1	01	Base Porta Basculante Base Puerta Basculante Basculating Door Base	1168x295x15
06	1/1	01	Prateleira Estante Shelf	1168x250x15
07	1/1	01	Tampo Tapa Top	1200x310x15
08	1/1	01	Fundo Fondo Bottom	1192x466x3
09	1/1	01	Fundo Estreito Fondo Estrecho Narrow Bottom	1192x202x3
10	1/1	01	Porta de Vidro Reflecta Puerta de cristal reflectante Reflecta Glass Door	1195x458x20

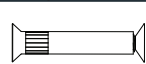
Ferragens | Herrajes | Hardware

A  Parafuso 5,0x50mm FLA. Tornillo 5,0x50mm FLA. Screw 5,0x50mm FLA.	B  Parafuso 3,5x40mm CHT. Tornillo 3,5x40mm CHT. Screw 3,5x40mm CHT.	C  Parafuso 3,5x12mm FLA. Tornillo 3,5x12mm FLA. Screw 3,5x12mm FLA.	D  Parafuso 3,5x12mm CHT. Tornillo 3,5x12mm CHT. Screw 3,5x12mm CHT.	E  Parafuso União 15mm Tornillo Unión 15mm Union Screw 15mm
F  Cavilha 8x25mm Cinta 8x25mm Dowel 8x25mm	G  Prego 10x10mm Clavo 10x10mm Nail 10x10mm	H  Perfil de Tirador 2015 - 150mm Profile Handle 2015 - 150mm	I  Fixador de fundos Bottom fixer	J  Kit Pistão a Gás 60N Kit Pistón a Gas 60N 60N Gas Piston Kit
K  Dobradiça metal 35mm Alta Bisagras metálicas 35mm Alta Metal hinge 35mm High	L  Calço metal Super Alto 8mm Calzado metálico Super Alto 8mm Super 8mm metal chock	M  Batente PVC para Porta Parada de PVC para Puerta PVC Door Stop	N  Buchas de plástico 8mm 8mm plastic bushing	O  Suporte de fixação Soporte de fijación Mounting bracket
P  Proteção para cantoneira Ángulo de protección Protection angle	Q  Sachê de cola Bolsa de pegamento Glue bag	R  Adesivo tapa parafuso 10mm Adhesivo tapón de tornillo 10mm Bolt cover adhesive 10mm	S  Parafuso União 30mm Tornillo Unión 30mm Union Screw 30mm	T  Giz de correção Tiza de corrección Chalk of correction

U

Etiqueta resinada Henn
Etiqueta resinada Henn
Henn resin label

 O parafuso (S) deve ser usada somente quando este módulo for acoplado a outro módulo componível Henn.

 El tornillo (S) se debe utilizar sólo cuando el módulo está conectado a otro módulo componible Henn.

 The screw (S) should be used only when this module is attached to another Henn modular module.

RECOMENDAÇÃO

Para fixar o móvel na parede usar o suporte de fixação (O), o parafuso 3,5x12mm FLA (C), a Bucha 8mm (N) e o parafuso 5,0x50mm FLA (A).

RECOMENDACIÓN

Para conectar el móvil a la pared con el soporte (O), tornillo 3,5 x12mm FLA (C), el casquillo de 8 mm (N) y el 5,0 x50mm tornillo FLA (A).

RECOMENDATION

To fix the furniture to the wall use the fixing bracket (O), the 3.5x12mm FLA (C) screw, the 8mm bushing (N) and the 5.0x50mm FLA (A).

Balcão Pia 02 Gavetas 03 Portas Connect

Pia Contador 02 Cajones 03 Puertas Connect | Balcony Pia 02 Drawers 03 Doors Connect

C66-35 Duna/Cristal | C66-42 Fendi

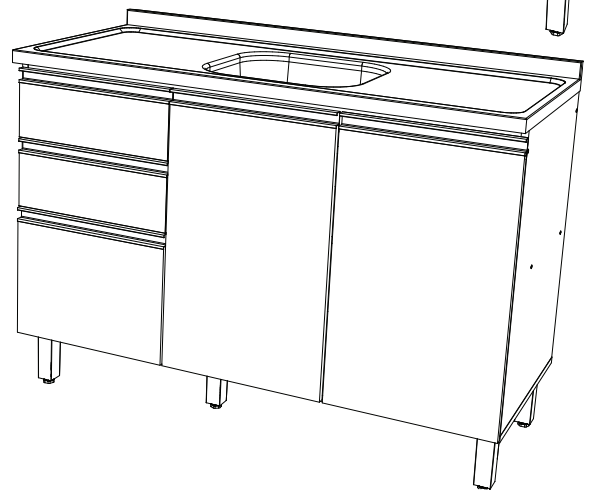
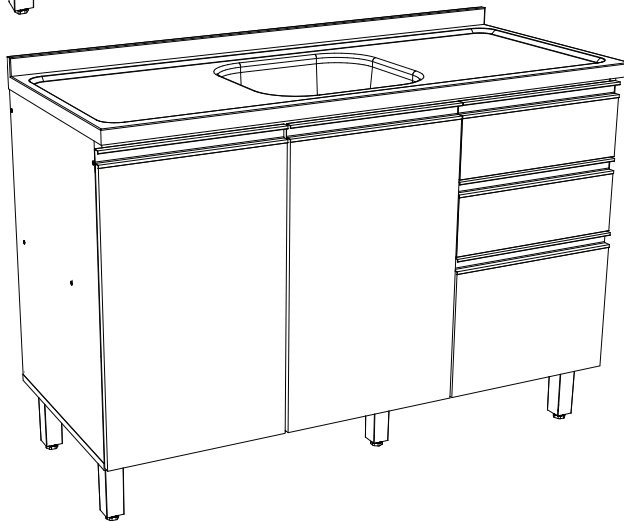
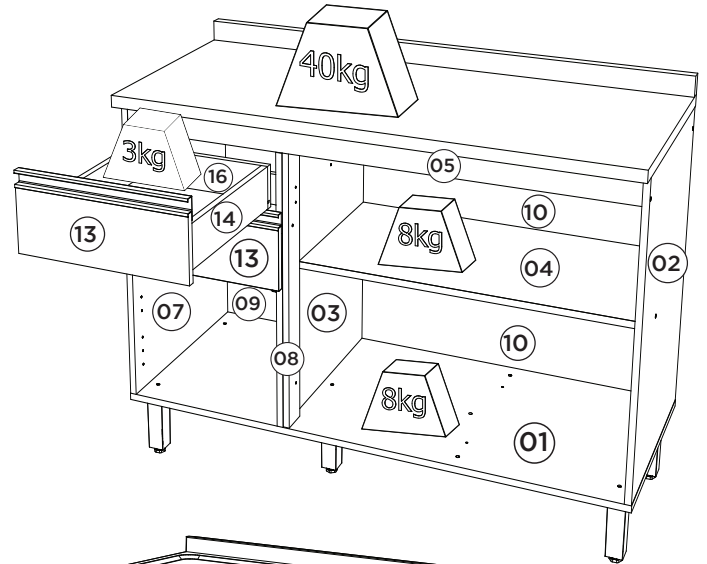
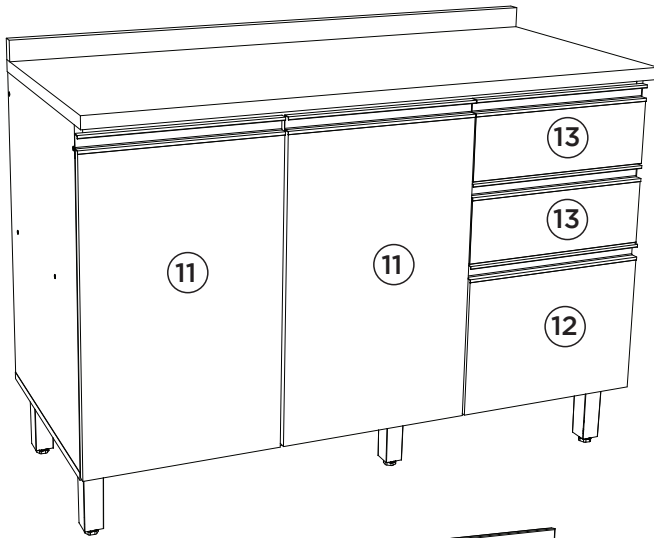

Pesos máximos recomendados com carga distribuída
Peso máximo recomendado con la carga distribuida
Recommended maximum weights with evenly distributed.

Requisitos para montagem Requisitos para la montaje Assembly Requirements

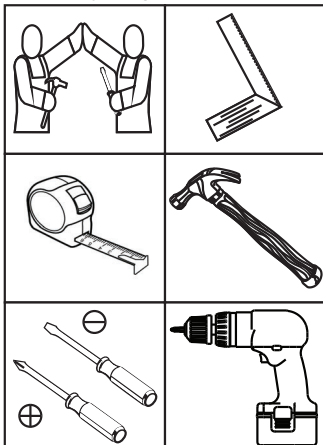

Imagens meramente ilustrativas, não acompanha o produto.
Imágenes ilustrativas, no incluidas con el producto.
Illustrative images, not included with the product.

AVISO

Para limpeza de seu móvel, use uma flanela seca ou umedecida, e não utilize produtos químicos que possam danificar seu produto.

SISTEMA DE MONTAGEM

O sistema de montagem dos produtos, funciona de acordo com a ordem crescente dos números indicados no desenho. Ex: 01, 02, 03, 04... até a conclusão da montagem.

ASSISTÊNCIA TÉCNICA

Para solicitação de Assistência Técnica você consumidor deverá entrar em contato com o Lojista o qual você realizou a compra deste produto e solicitar a assistência técnica das peças avariadas. A garantia abrange todas as peças, partes e componentes que eventualmente venham apresentar defeito de fabricação no prazo de 03 (três) meses, contando a partir da entrega do produto ao consumidor, mediante nota fiscal de compra. Se houver qualquer alteração na estrutura do produto ou ocorrer defeito por negligência do montador/consumidor em relação a instrução de montagem e manuseio, não será fornecido assistência técnica gratuita.

ADVERTENCIA

Para limpieza de su móvil, use una flanela seca o húmeda, y no utilice productos químicos que puedan dañar su producto.

SISTEMA DE MONTAJE

El sistema de montaje de los productos funciona de acuerdo con el orden creciente de los números indicados en el dibujo. Ej.: 01, 02, 03, 04... hasta la conclusión del montaje.

ASISTENCIA TÉCNICA

Para solicitar Asistencia Técnica, el consumidor debe comunicarse con el Comercio que usted realizó la compra de este producto y solicita asistencia técnica para las partes dañadas. La garantía cubre todas las partes, piezas y componentes que eventualmente puedan presentar defecto de fabricación en el plazo de 03 (tres) meses, contados a partir de la entrega del producto al consumidor, mediante factura de compra. Si se produce algún cambio en la estructura del producto o se produce un defecto por negligencia del montador/consumidor en relación con las instrucciones de montaje y manipulación, no se prestará asistencia técnica gratuita.

NOTICE

To clean your furniture, use a dry or wet cloth, and do not use chemicals that may damage your product.

ASSEMBLY SYSTEM

The products' assembly system works according to the increasing order of the indicated numbers. For example: 01, 02, 03, 04 ... to the end of the assembly.

TECHNICAL ASSISTANCE

To request Technical Assistance, the consumer must contact the retailer from whom you purchased this product and request technical assistance for the damaged parts. The warranty covers all parts, parts and components that may eventually present a manufacturing defect within a period of 03 (three) months, counting from the delivery of the product to the consumer, by means of a purchase invoice. If there is any change in the structure of the product or defect occurs due to negligence of the assembler/consumer in relation to the assembly and handling instruction, free technical assistance will not be provided.

1º

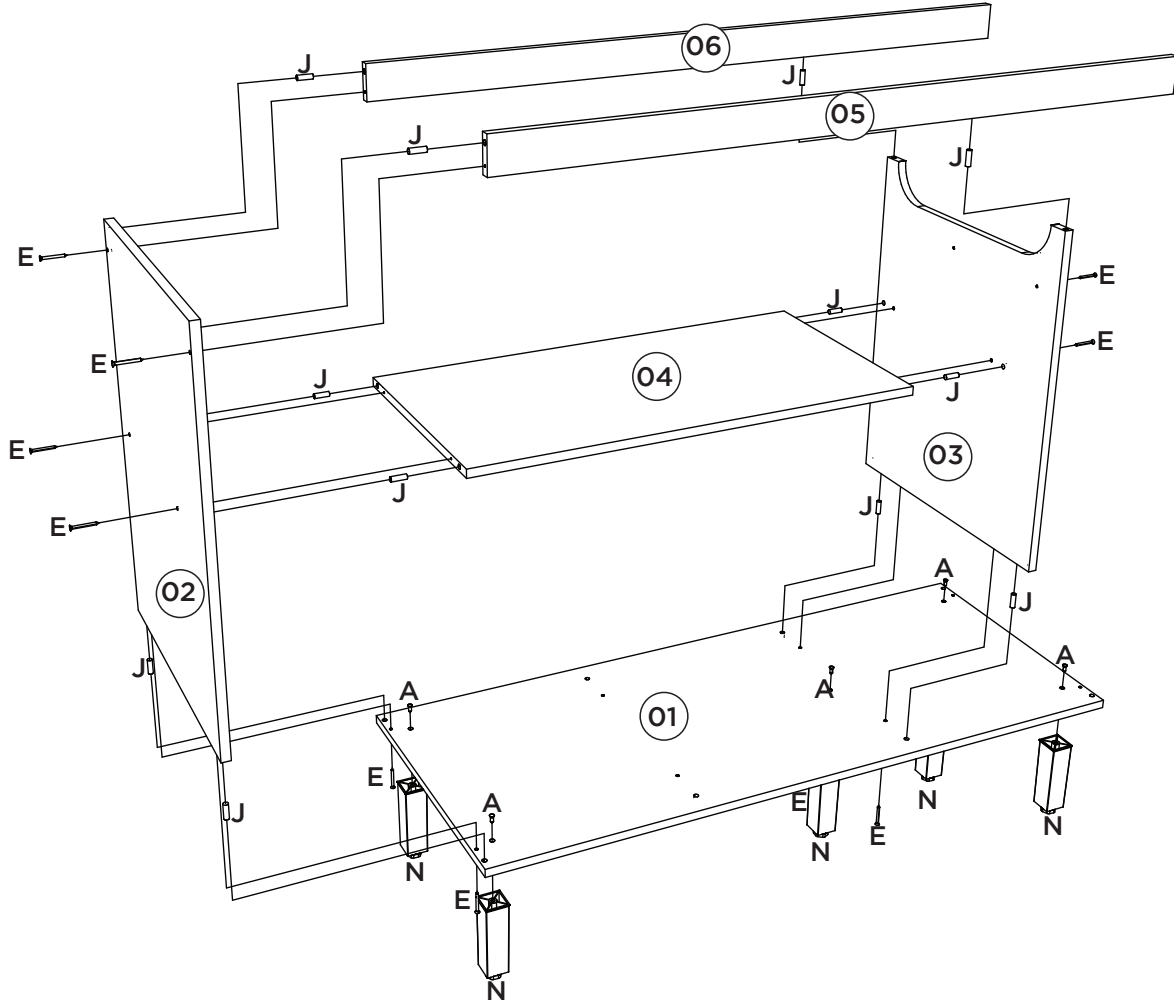

2º

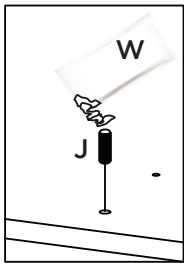

Utilizar o sachê de cola (W) em todas as cavilhas (J) do produto.

Con el pegamento sobre (W) en todos los pernos (J) producto.

Use the glue sachet (W) on all the pegs (J) of the product.

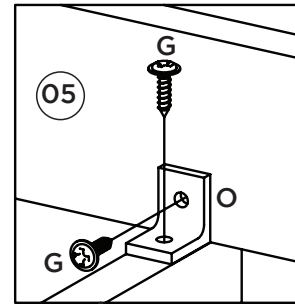

A pilastra da porta (08) deve estar alinhada com a divisão (03).

El pilar de la puerta (08) debe estar alineada con la división (03).

The door pillar (08) must be aligned with the partition (03).

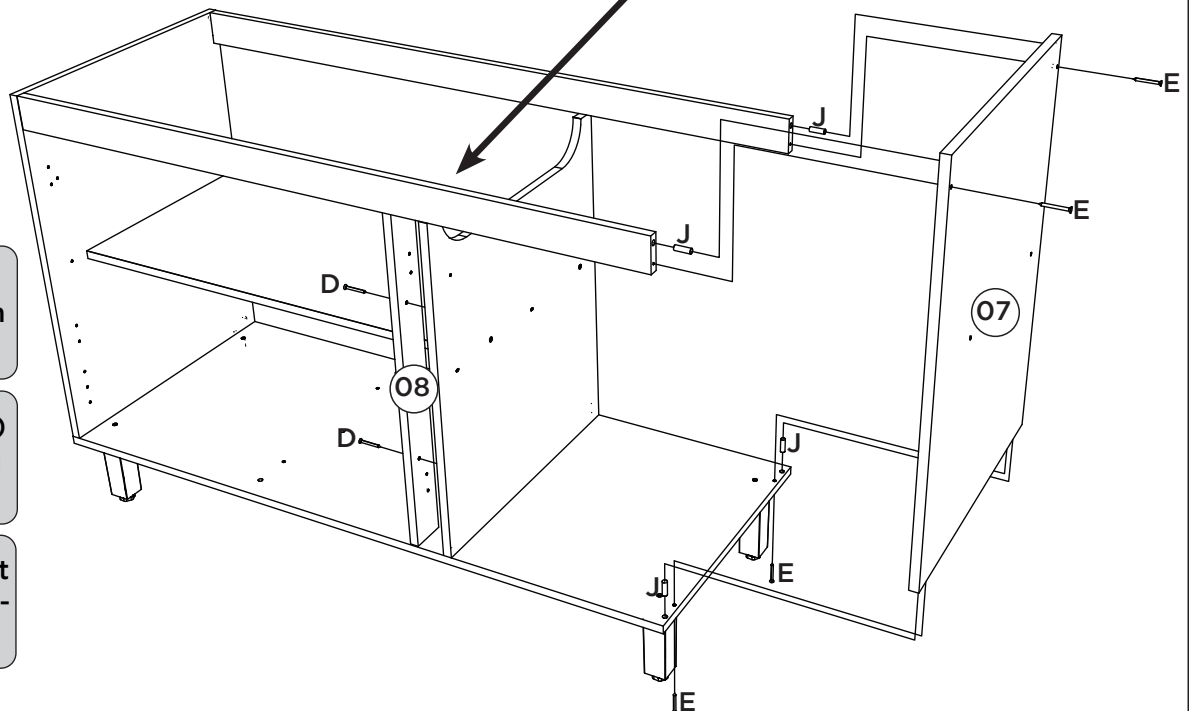

3º

Esse tampo é opcional e é vendido separadamente (C905-33).

Esta vez es opcional y se vende por separado (C905-33).

This top is optional and is sold separately (C905-33).

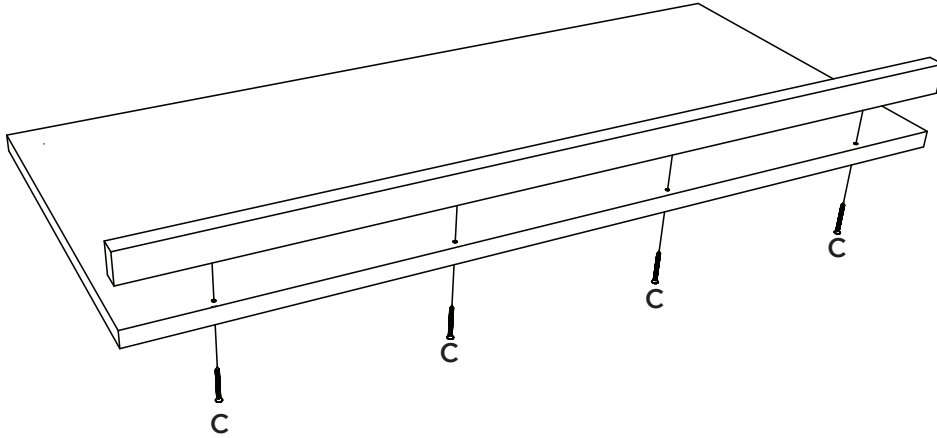

4º

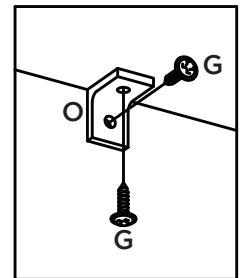
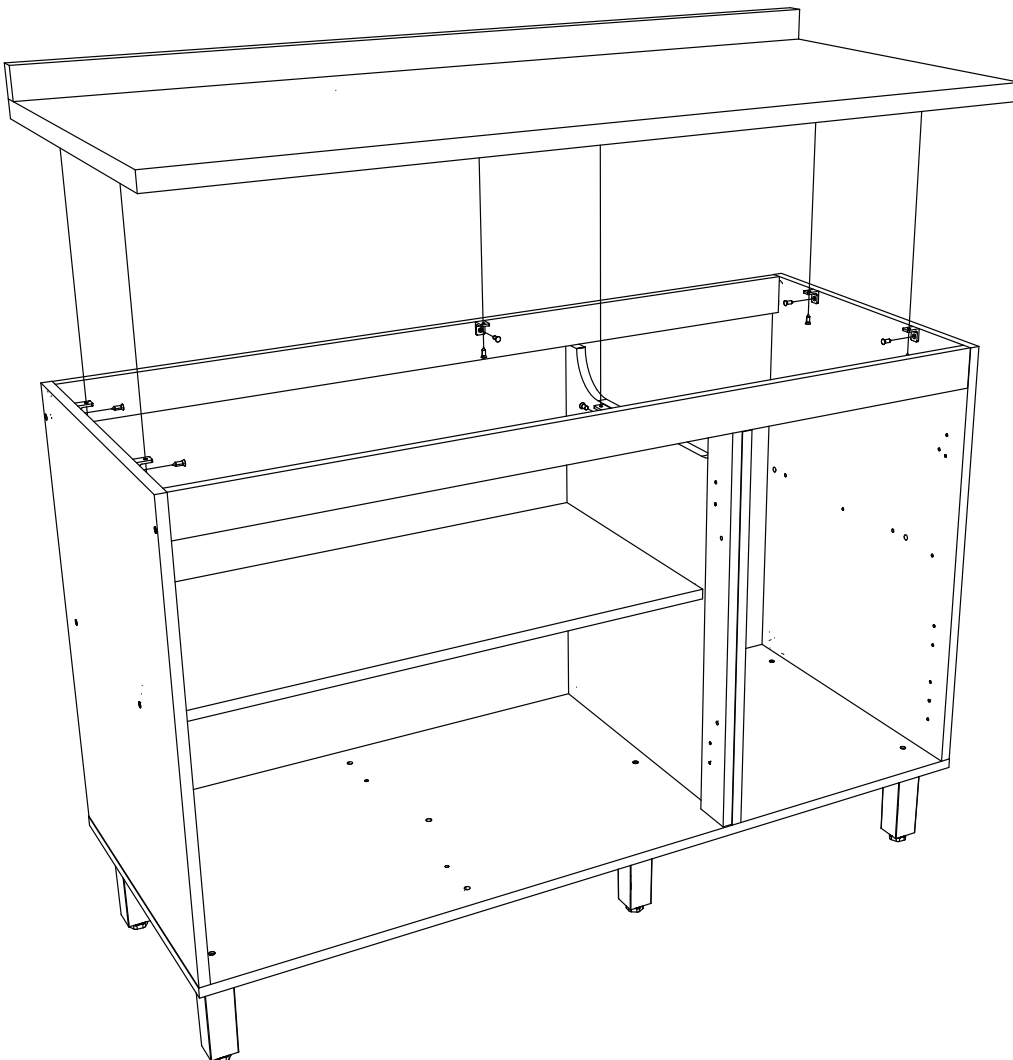

Caso o móvel seja montado com a opção do tampo, fixar o mesmo com 06 cantoneiras (O) e os parafusos 3,5x14mm (G).

Si se monta el auricular con la opción de la cubierta, fijarlo con Los ángulos 06 (O) y 3,5 x14mm tornillos (G).

If the furniture is to be installed with the top cover option, fix it with 06 (O) and 3.5x14mm screws (G).

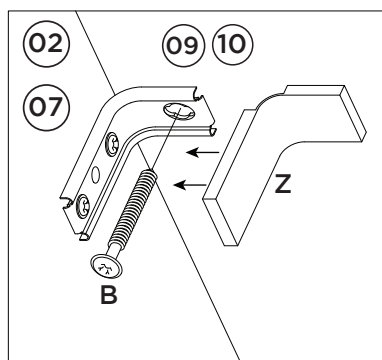
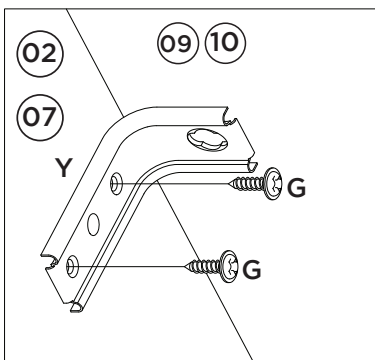
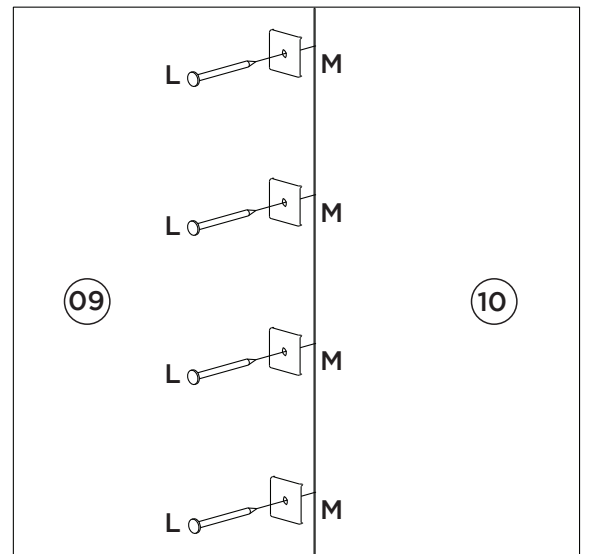
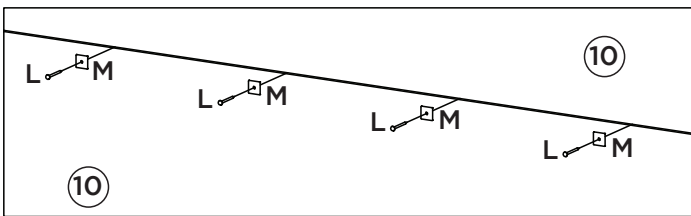
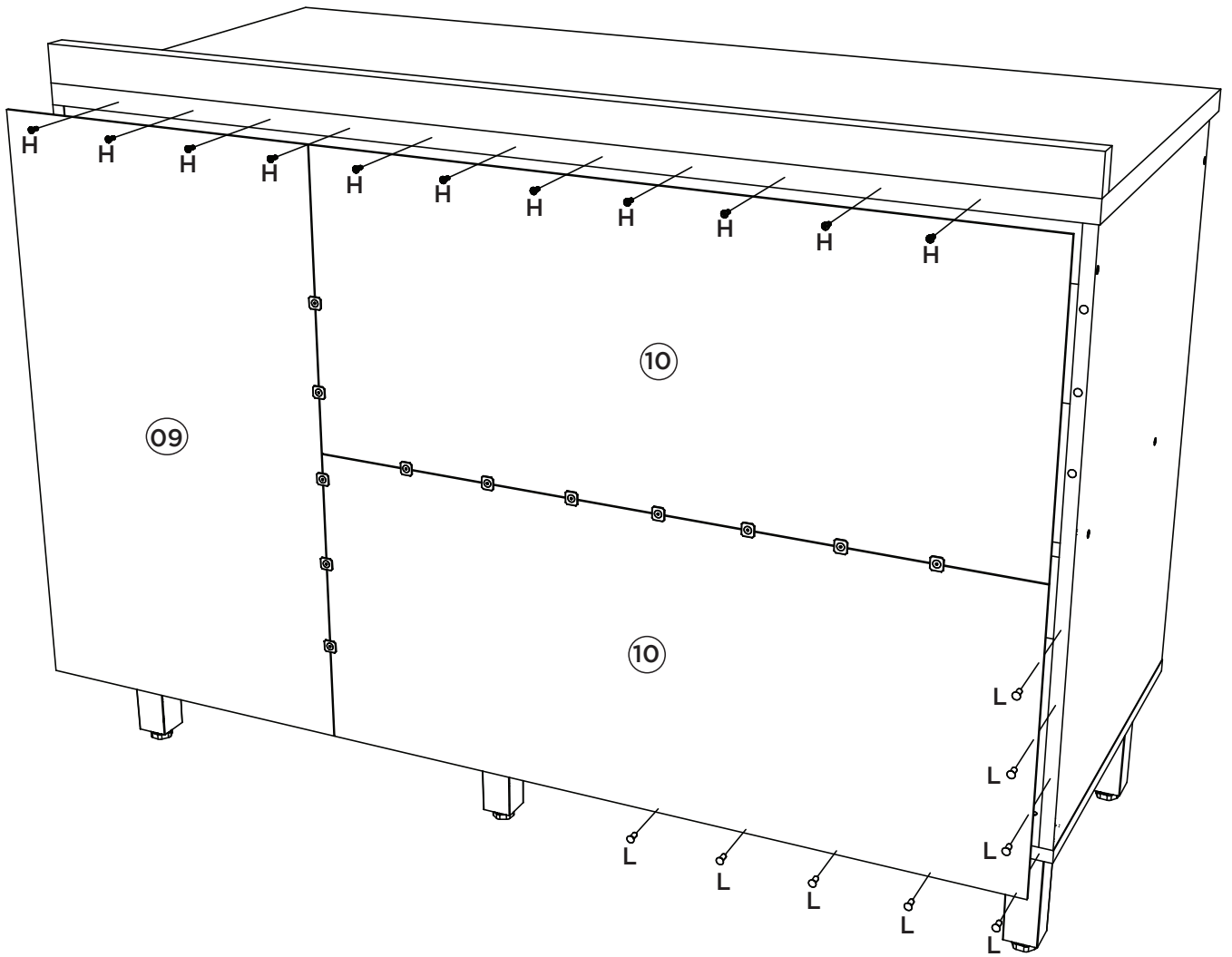

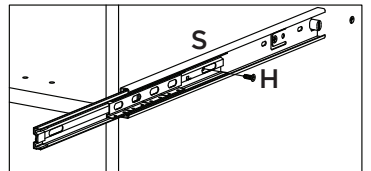
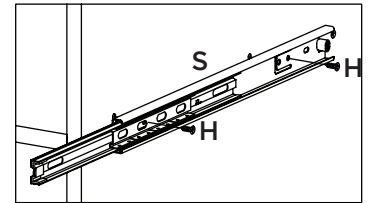
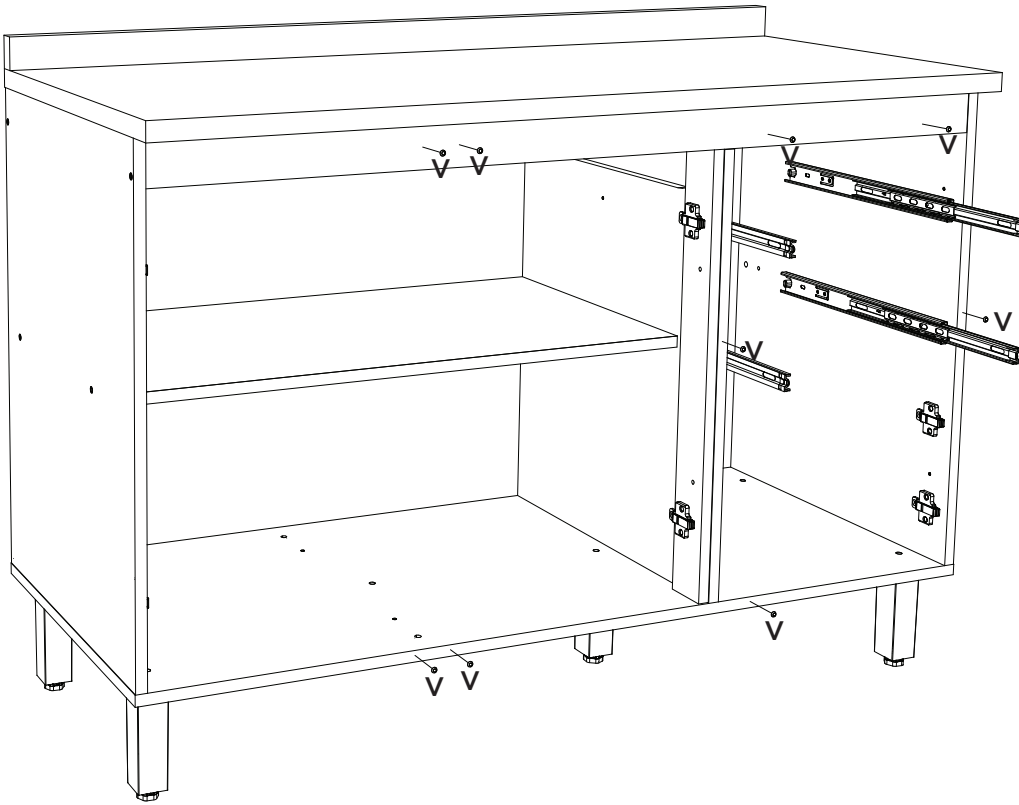

Fixação da correção telescópica (S).

Fijación Slide telescópico (S).

Fixing of the telescopic slide (S).

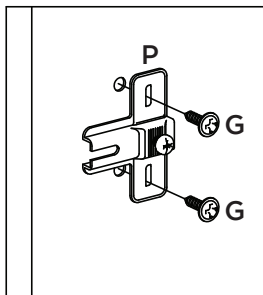

Fixação do calço 5mm (P).

Montaje de la placa de 5mm (P).

Shim fixation 5mm (P).

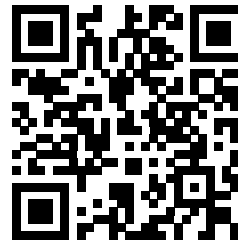

Vídeo: Dicas para fixar a Correção

Video: Consejos para arreglar la diapositiva

Video: Tips for Fixing the Slide

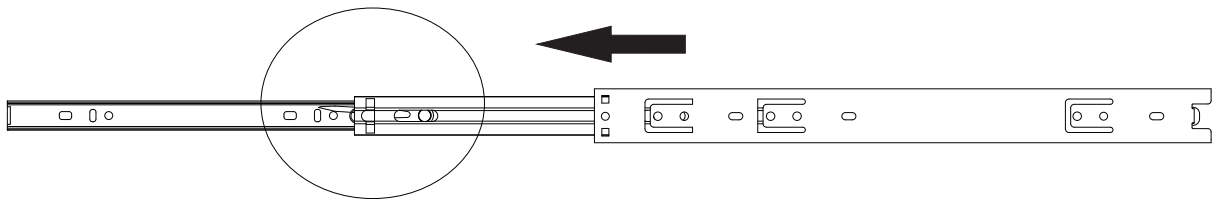

Para a desmontagem da correção siga a instrução ao lado.

Para el desmontaje seguimiento de diapositivas la instrucción siguiente a.

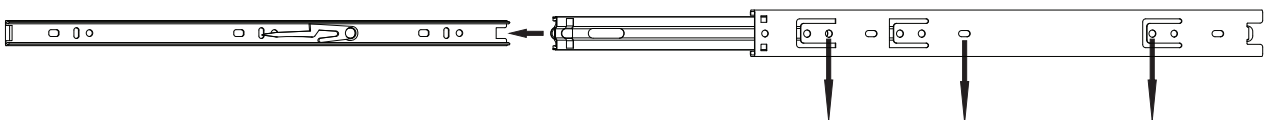
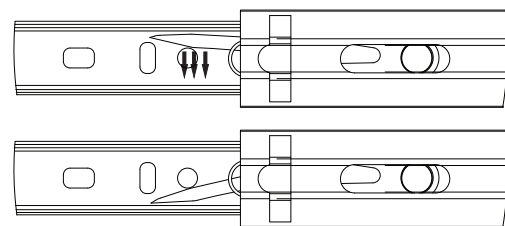

Fixar as correções nessas furações

Fijar las diapositivas de estos agujeros



Vídeo: Instalar e regular Dobradiças

Vídeo: Instale y ajuste las bisagras

Vídeo: Install and adjust hinges

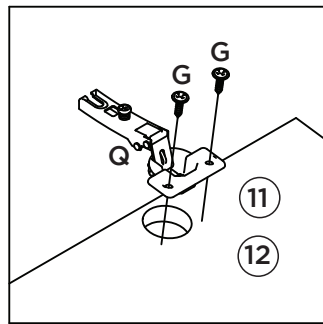

Fixação da dobradiça (Q).

La fijación de la bisagra (Q).

Hinge fixing (Q).

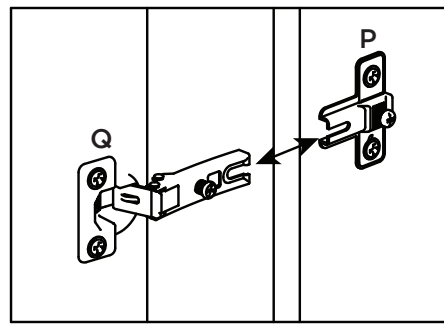

Encaixe da dobradiça (Q) com o calço (P).

Fije la bisagra (Q) con cuña (P).

Hinge fitting (Q) with shim (P).

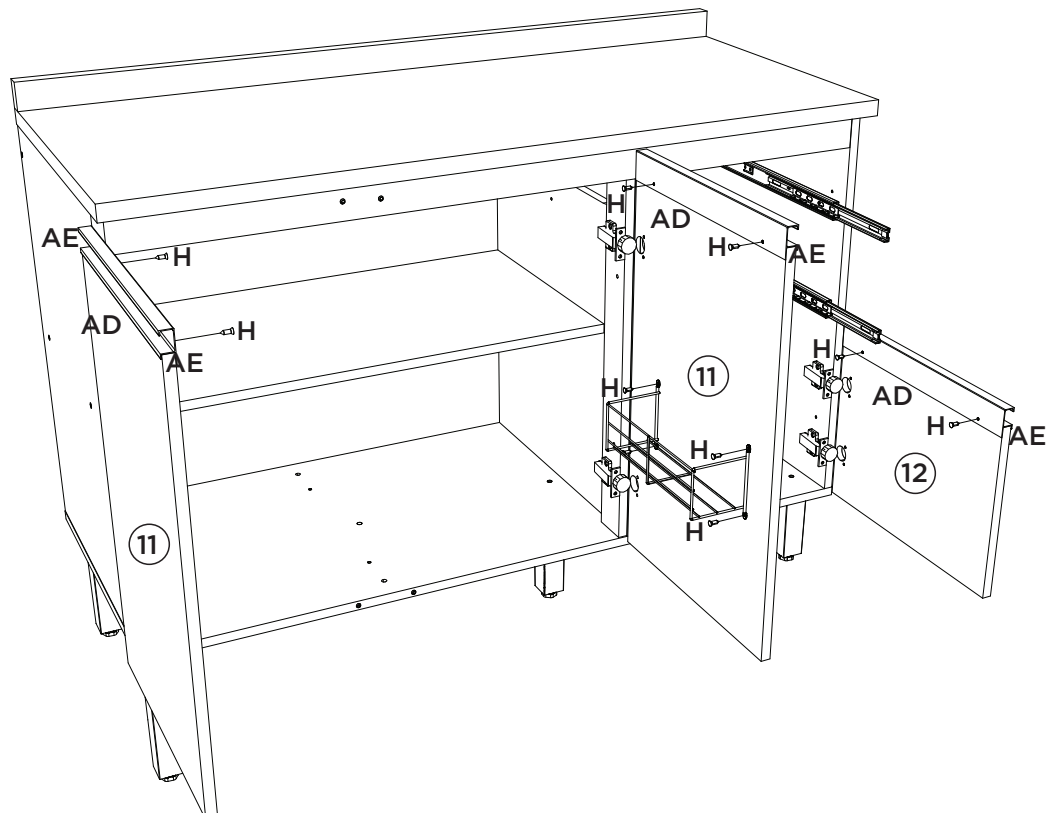
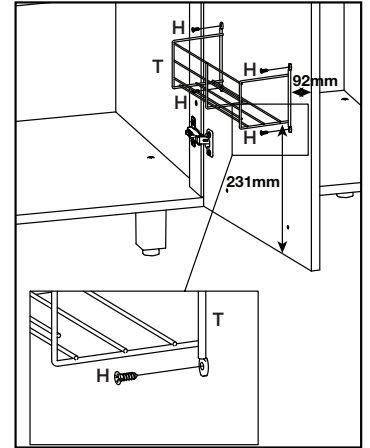
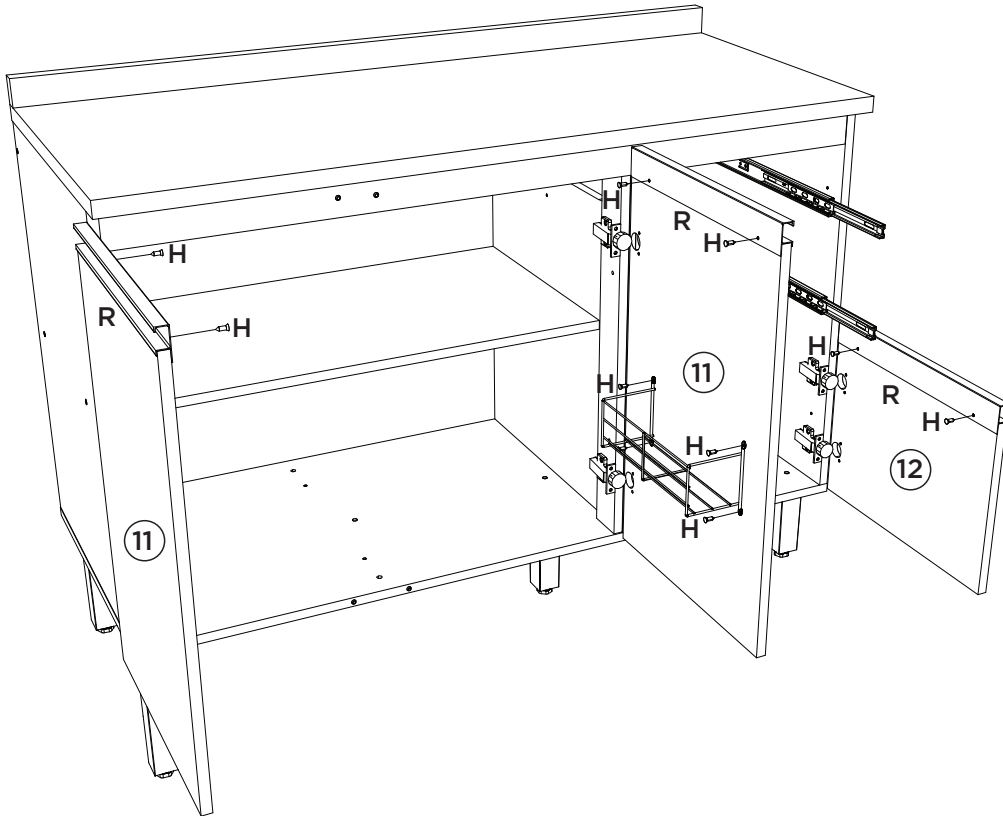

Somente para (C66-139)

Solo para (C66-139)

Only for (C66-139)

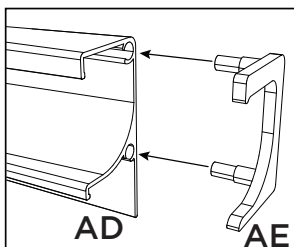

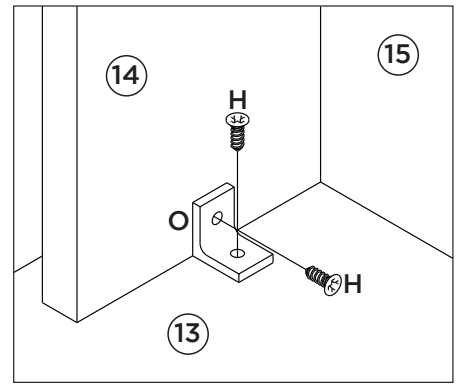
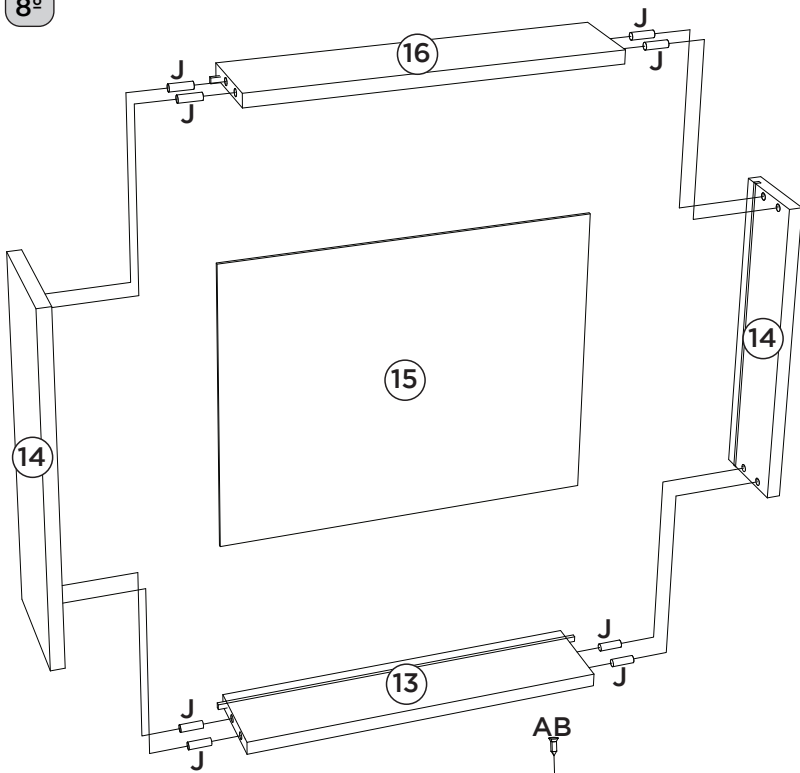

Somente para (C66-139)

Solo para (C66-139)

Only for (C66-139)

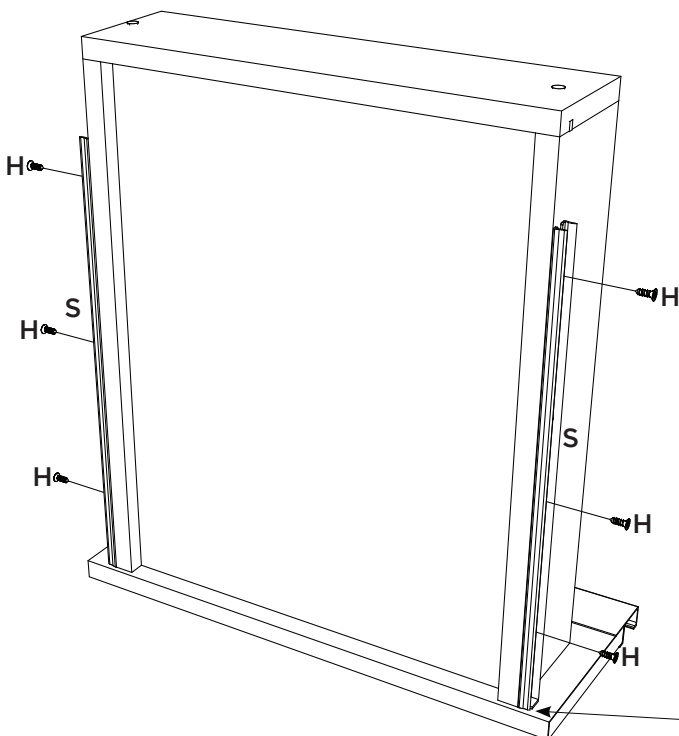
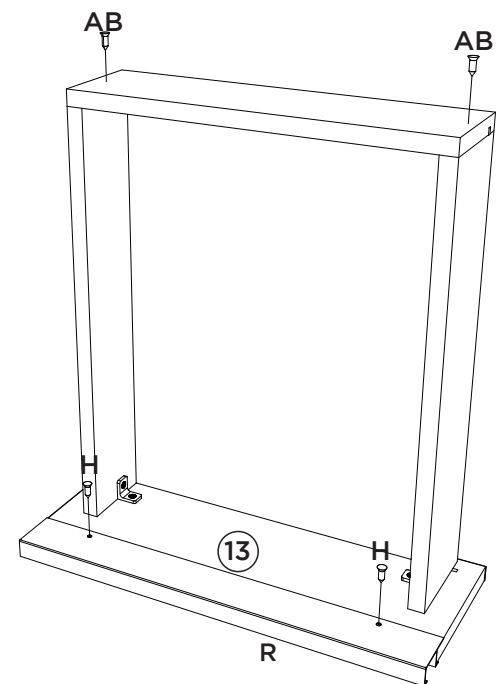
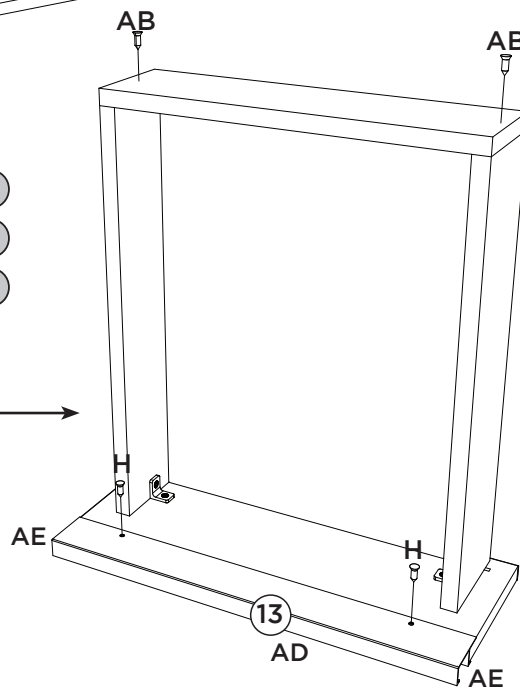
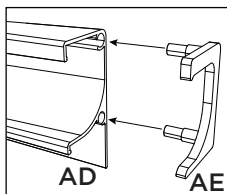

A corredeira (S) deverá ser alinhada com a parte de baixo do lado de gaveta (14).

La carcasa (S) será alineada con la parte de por el lado del cajón (14).

The slide (S) should be aligned with the underside of the drawer side (14).











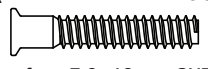
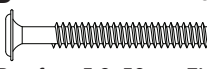

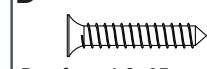
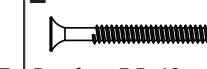





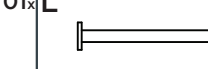
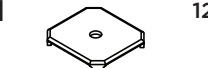
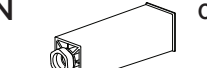



Deixar 3mm de distância da frente de gaveta.

Deje una separación de 3mm del frente del cajón.

Leave 3mm away from the front of the drawer.

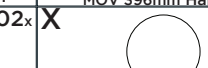
Item	Caixa Caja Box	Qtd Ctd Qty	Descrição Descripción Description	Medidas (mm) Dimensions (mm) Size (measurements) (mm)
01	1/1	01	Base Base Base	1200x490x15
02	1/1	01	Lateral esquerda Lateral izquierda Left side	660x490x15
03	1/1	01	Divisão División Division	600x490x15
04	1/1	01	Prateleira Estante Shelf	783x400x15
05	1/1	01	Travessa frontal Travesaño frontal Front crossbar	1168x60x15
06	1/1	01	Travessa traseira Travesaño trasero Rear bumper	1168x60x15
07	1/1	01	Lateral direita Lateral derecha Right side	660x490x15
08	1/1	01	Pilastra da Porta Pilastra Puerta Pilaster door	599x60x15
09	1/1	01	Fundo menor Fondo menor Minor fund	683x389x3
10	1/1	02	Fundo Fondo Bottom	802x341x3
11	1/1	02	Porta Puerta Door	625x396x15
11	1/1	02	Porta Puerta Door (Somente para C66-139)	629x396x15
12	1/1	01	Porta menor Puerta menor Smaller door	396x290x15
12	1/1	01	Porta menor Puerta menor Smaller door (Somente para C66-139)	396x294x15
13	1/1	02	Frente de gaveta Frente de cajón Front of drawer	396x136x15
13	1/1	02	Frente de gaveta Frente de cajón Front of drawer (Somente para C66-139)	396x140x15
14	1/1	04	Lado de Gaveta menor Lado del cajón menor Smallest Drawer Side	400x90x15
15	1/1	02	Fundo de gaveta Fondo de cajón Bottom of drawer	411x326x3
16	1/1	02	Ripa de trás Malla detrás Rear lath	345x90x15

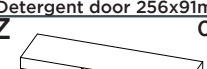
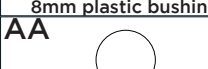
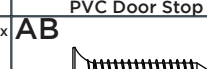
Ferragens | Herrajes | Hardware

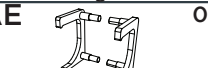
A  Parafuso 7,0x40mm CHT. Tornillo 7,0x40mm CHT. Screw 7,0x40mm CHT.	B  Parafuso 5,0x50mm FLA. Tornillo 5,0x50mm FLA. Screw 5,0x50mm FLA.	C  Parafuso 4,5x50mm CHT. Tornillo 4,5x50mm CHT. Screw 4,5x50mm CHT.	D  Parafuso 4,0x25mm CHT. Tornillo 4,0x25mm CHT. Screw 4,0x25mm CHT.	E  Parafuso 3,5x40mm CHT. Tornillo 3,5x40mm CHT. Screw 3,5x40mm CHT.	F  Divisor talheres 398x313mm Divisor cubiertos 398x313mm Cutlery divider 398x313mm
G  Parafuso 3,5x14mm FLA. Tornillo 3,5x14mm FLA. Screw 3,5x14mm FLA.	H  Parafuso 3,5x12mm CHT. Tornillo 3,5x12mm CHT. Screw 3,5x12mm CHT.	I  Giz de correção Tiza de corrección Chalk of correction	J  Cavilha 8x25mm Cinta 8x25mm Dowel 8x25mm	K  Etiqueta resinada Henn Etiqueta resinada Henn Henn resin label	L  Prego 10x10mm Clavo 10x10mm Nail 10x10mm
M  Fixador de fundos Fijador de fondos Bottom fixer	N  Pé 145mm x 42mm Pie 145mm x 42mm Foot 145mm x 42mm	O  Cantoneira plástica Cantонера plástica Plastic angle brackets	P  Calço metal médio 0mm Calzado metálico medio 0mm Metal shim 0mm	Q  Dobradiça metal Baixa 35mm Bisagra metálica Baja 35mm Metal hinge Low 35mm	R  Puxador MOV 396mm Tirador MOV 396mm MOV 396mm Handle
S  Corrediza telescópica Diapositivas telescópicas Telescopic slides	T  Porta detergente 256x91mm Puerta detergente 256x91mm Detergent door 256x91mm	U  Bucha plástica 8mm Bucha de plástico 8mm 8mm plastic bushing	V  Batente PVC para Porta Parada de PVC para Puerta PVC Door Stop	W  Sachê de cola Bolsa de pegamento Glue bag	X  Adesivo tapa parafuso 17mm Adhesivo tapón de tornillo 17mm Bolt cover adhesive 17mm
Y  Suporte de fixação Soporte de fijación Mounting bracket	Z  Proteção para cantoneira Ángulo de protección Protection angle	AA  Adesivo tapa parafuso 10mm Adhesivo tapón de tornillo 10mm Bolt cover adhesive 10mm	AB  Parafuso 3,0x30mm CHT. Tornillo 3,0x30mm CHT. Screw 3,0x30mm CHT.	AC  Parafuso União 30mm Tornillo Unión 30mm Union Screw 30mm	AD  Puxador MOV4083 - 392mm Tirador MOV4083 - 392mm MOV4083 - 392mm Handle
AE  Kit Ponteira Plástica MOV4083 Kit de punta de plástico MOV4083 Plastic Tip Kit MOV4083					

Somente para (C66-139)

Solo para (C66-139)

Only for (C66-139)



O parafuso (AC) deve ser usada somente quando este módulo for acoplado a outro módulo componível Henn.

RECOMENDAÇÃO

Para fixar o móvel na parede usar o suporte de fixação (Y), o parafuso 3,5x14mm FLA (G), a Bucha 8mm (U) e o parafuso 5,0x50mm FLA (B).



El tornillo (AC) se debe utilizar sólo cuando el módulo está conectado a otro módulo componible Henn.

RECOMENDACIÓN

Para conectar el móvil a la pared con el soporte (Y), tornillo 3,5 x14mm FLA (G), el casquillo de 8 mm (U) y el 5,0 x50mm tornillo FLA (B).



The screw (AC) should be used only when this module is attached to another Henn modular module.

RECOMMENDATION

To fix the furniture to the wall use the mounting bracket (Y), the 3.5x14mm FLA (G) screw, the 8mm bushing (U) and the 5.0x50mm FLA (B).

Cristaleira 4 Portas 715mm Connect | Gabinete 4 Puertas 715mm Connect | Cabinet 4 Doors 715mm Connect

Referência/Cor
c C71-35 - Duna/Cristal
c C71-42 - Fendi
c C71-139 - Off White

Requisitos para montagem
Requisitos para la montaje
Assembly Requirements

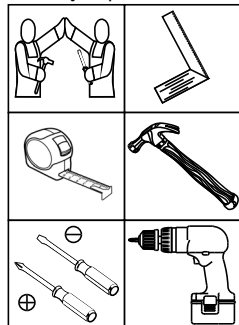

Imagens meramente ilustrativas, não acompanha o produto.
Imágenes ilustrativas, no incluidas con el producto.
Illustrative images, not included with the product.

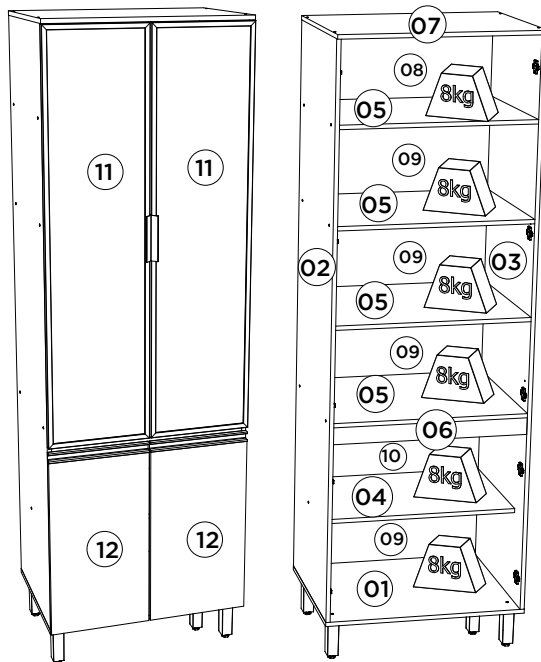

Pesos máximos recomendados com carga distribuída
Peso máximo recomendado con la carga distribuída
Recommended maximum weight with distributed load.

AVISO
Para limpeza de seu móvel, use uma flanela seca ou umedecida, e não utilize produtos químicos que possam danificar seu produto.

SISTEMA DE MONTAGEM
O sistema de montagem dos produtos, funciona de acordo com a ordem crescente dos números indicados no desenho. Ex: 01, 02, 03, 04... até a conclusão da montagem.

ASSISTÊNCIA TÉCNICA
Para solicitação de Assistência Técnica você consumidor deverá entrar em contato com o Lojista ou qual você realizou a compra deste produto e solicitar a assistência técnica das peças avariadas. A garantia abrange todas as peças, partes e componentes que eventualmente venham apresentar defeito de fabricação no prazo de 03 (três) meses, contando a partir da entrega do produto ao consumidor, mediante nota fiscal de compra. Se houver qualquer alteração na estrutura do produto ou ocorrer defeito por negligência do montador/consumidor em relação a instrução de montagem e manuseio, não será fornecido assistência técnica gratuita.

ADVERTENCIA
Para limpieza de su móvil, use una flanela seca o húmeda, y no utilice productos químicos que puedan dañar su producto.

SISTEMA DE MONTAJE
El sistema de montaje de los productos funciona de acuerdo con el orden creciente de los números indicados en el dibujo. Ej.: 01, 02, 03, 04... hasta la conclusión del montaje.

ASISTENCIA TÉCNICA
Para solicitar Asistencia Técnica, el consumidor debe comunicarse con el Comercio que usted realizó la compra de este producto y solicita asistencia técnica para las partes dañadas. La garantía cubre todas las partes, piezas y componentes que eventualmente puedan presentar defecto de fabricación en el plazo de 03 (tres) meses, contados a partir de la entrega del producto al consumidor, mediante factura de compra. Si se produce algún cambio en la estructura del producto o se produce un defecto por negligencia del montador/consumidor en relación con las instrucciones de montaje y manipulación, no se prestará asistencia técnica gratuita.

NOTICE
To clean your furniture, use a dry or wet cloth, and do not use chemicals that may damage your product.

ASSEMBLY SYSTEM
The products' assembly system works according to the increasing order of the indicated numbers. For example: 01, 02, 03, 04... to the end of the assembly.

TECHNICAL ASSISTANCE
To request Technical Assistance, the consumer must contact the retailer from whom you purchased this product and request technical assistance for the damaged parts. The warranty covers all parts, parts and components that may eventually present a manufacturing defect within a period of 03 (three) months, counting from the delivery of the product to the consumer, by means of a purchase invoice. If there is any change in the structure of the product or defect occurs due to negligence of the assembler/consumer in relation to the assembly and handling instruction, free technical assistance will not be provided.

Lista de Peças | Lista de piezas | List of parts

Item	Caixa Caja Box	Qtd Ctd Qty	Descrição Descripción Description	Medidas (mm) Dimensions (mm) Size (measurements) (mm)
01	2/2	01	Base Base Base	715x490x15
02	1/2	01	Lateral esquerda Lateral izquierda Left side	2030x490x15
03	1/2	01	Lateral direita Lateral derecha Right side	2030x490x15
04	2/2	01	Prateleira Inferior Estante Inferior Bottom Shelf	683x400x15
05	2/2	04	Prateleira Estante Shelf	683x490x15
06	2/2	01	Travessa frontal Travesaño frontal Front crossbar	683x60x15
07	1/2	01	Tampo Tapa Top	715x505x15
08	2/2	01	Fundo Superior Fondo superior Superior background	707x306x3
09	1/2	04	Fundo Inferior Fondo inferior Bottom background	707x341x3
10	2/2	01	Fundo Fondo Bottom	707x376x3
11	1/2	02	Porta de Vidro Reflecta Cristal de la puerta Reflecta Reflecta Glass Door	1367x350x20
12	1/2	02	Porta Puerta Door	625x354x15
12	1/2	02	Porta Puerta Door (Somente para C71-139)	629x354x15

Ferragens | Herrajes | Hardware

A 04x Parafuso 7,0x40mm CHT. Tornillo 7,0x40mm CHT. Screw 7,0x40mm CHT.	B 01x Parafuso 5,0x50mm FLA. Tornillo 5,0x50mm FLA. Screw 5,0x50mm FLA.	C 04x Parafuso União 30mm Tornillo Unión 30mm Union Screw 30mm
D 22x Parafuso 3,5x40mm CHT. Tornillo 3,5x40mm CHT. Screw 3,5x40mm CHT.	E 01x HENN Etiqueta resinada Henn Etiqueta resinada Henn Henn resin label	F 44x Parafuso 3,5x12mm FLA. Tornillo 3,5x12mm FLA. Screw 3,5x12mm FLA.
G 08x Parafuso 3,5x12mm CHT. Tornillo 3,5x12mm CHT. Screw 3,5x12mm CHT.	H 32x Cavilha 8x25mm Cinta 8x25mm Dowel 8x25mm	I 01x Sachê de cola Bolsa de pegamento Glue bag
J 92x Prego 10x10mm Clavo 10x10mm Nail 10x10mm	K 30x Fixador de fundos Fijador de fondos Bottom fixer	L 01x Proteção para cantoneira Ángulo de protección Protection angle
M 10x Calço metal Alto 3mm Calzado metálico Alto 3mm Metal chock High 3mm	N 10x Dobraçã metal 35mm Baixa Bisagra metálica 35mm Baja Metal hinge 35mm Low	O 02x Giz de correção Tiza de corrección Chalk of correction
P 01x Buchã plástica 8mm Buchã de plástico 8mm 8mm plastic bushing	Q 02x Perfil puxador 2015 150mm Perfil bastidor 2015 150mm Profile Handle 2015 150mm	R 02x Puxador MOV 354mm Tirador MOV 354mm MOV 354mm Handle
S 18x Adesivo tapa parafuso 10mm Adhesivo tapón de tornillo 10mm Bolt cover adhesive 10mm	T 04x Adesivo tapa parafuso 17mm Adhesivo tapón de tornillo 17mm Bolt cover adhesive 17mm	U 04x Pé 145mm x 42mm Pie 145mm x 42mm Foot 145mm x 42mm
V 08x Batente PVC para Porta Parada de PVC para Puerta PVC Door Stop	W 01x Suporte de fixação Soporte de fijación Mounting bracket	X 01x Conector de Montagem Conector de montaje Mounting Connector
Y 02x Puxador MOV4083 - 350mm Tirador MOV4083 - 350mm MOV4083 - 350mm Handle	Z 01x Kit Pontaíra Plástica MOV4083 Kit de punta de plástico MOV4083 Plastic Tip Kit MOV4083	

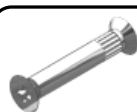

O parafuso (C) deve ser usada somente quando este módulo for acoplado a outro módulo componível Henn.



El tornillo (C) se debe utilizar sólo cuando el módulo está conectado a otro módulo componible Henn.



The screw (C) should be used only when this module is attached to another Henn modular module.

RECOMENDAÇÃO

Para fixar o móvel na parede usar o suporte de fixação (W), o parafuso 3,5x12mm FLA (F), a Bucha 8mm (P) e o parafuso 5,0x50mm FLA (B).

RECOMENDACIÓN

Para conectar el móvil a la pared con el soporte (W), tornillo 3,5 x12mm FLA (F), el casquillo de 8 mm (P) y el 5,0 x50mm tornillo FLA (B).

RECOMMENDATION

To fix the furniture to the wall use the fixing bracket (W), the 3.5x12mm FLA (F) screw, the 8mm bushing (P) and the 5.0x50mm FLA screw (B).

1º

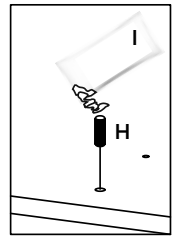
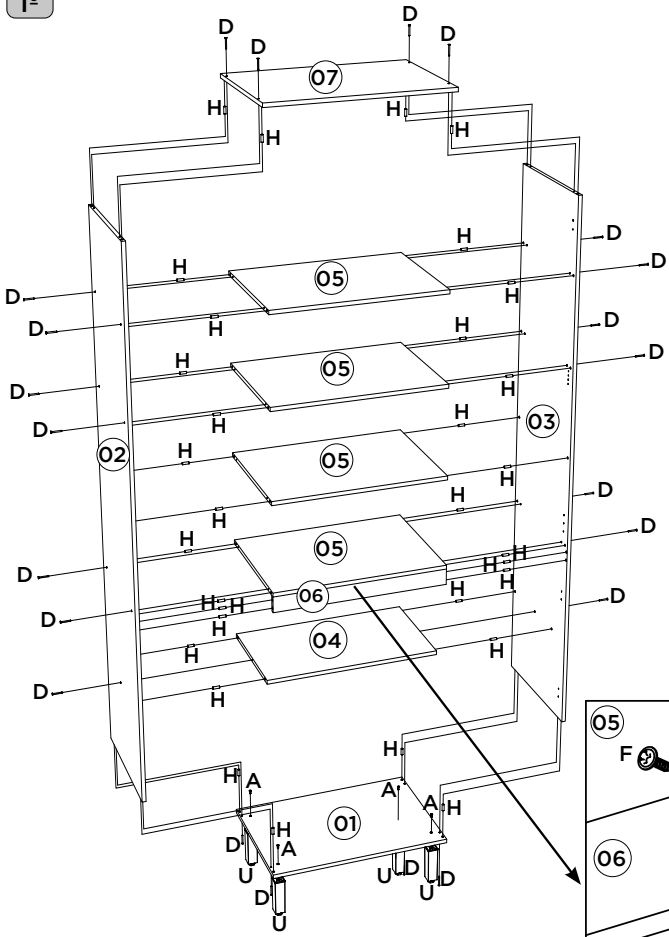

Utilizar o sachê de cola (I) em todas as cavilhas (H) do produto.

Con el pegamento sobre (I) en todos los pernos (H) producto.

Use the glue sachet (I) on all the pegs (H) of the product.

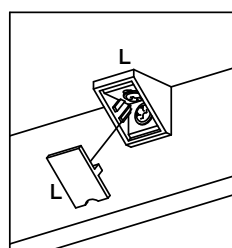
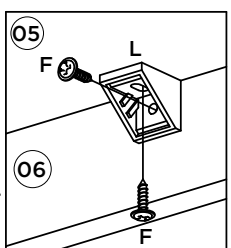

Conector de Montagem fixado Internamente

Conector de montaje fijado internamente

Mounting Connector fixed internally

2º

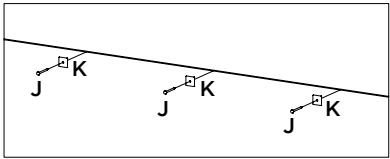
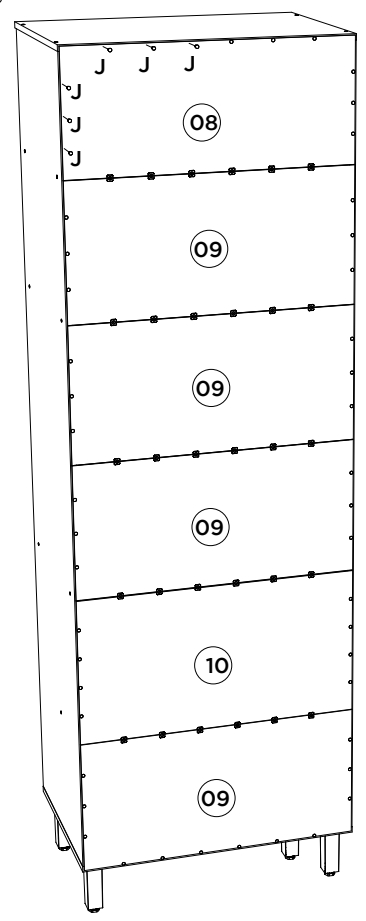

3º

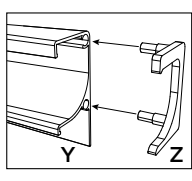
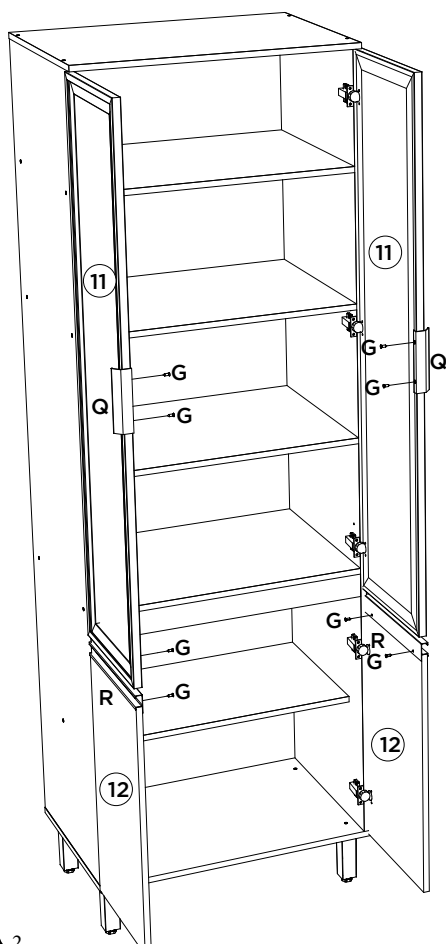

Somente para (C71-139)

Solo para (C71-139)

Only for (C71-139)

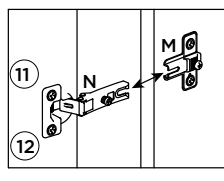
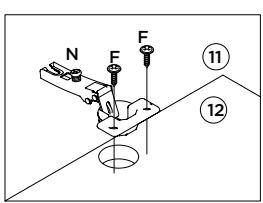
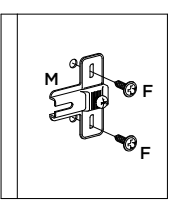

Vídeo: Instalar e regular Dobradiças

Vídeo: Instale y ajuste las bisagras

Vídeo: Install and adjust hinges

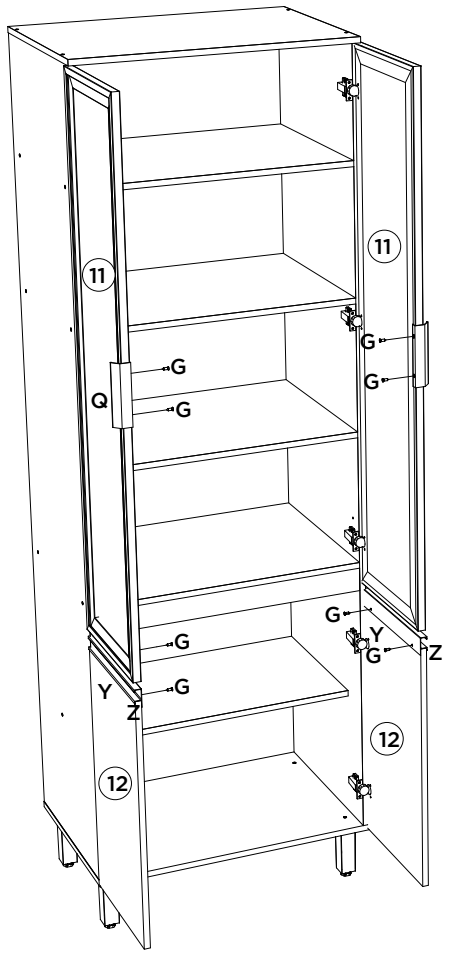
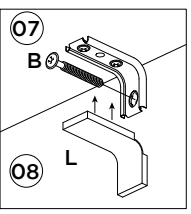
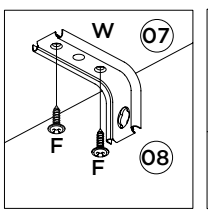

Aéreo 01 Porta Basculante 600mm Connect |
Aéreo 01 Puerta Basculante 600mm Connect |
01 air port Tipper 600mm Connect

- C77-35 - Duna/Cristal
- C77-42 - Fendi
- C77-139 - Off White

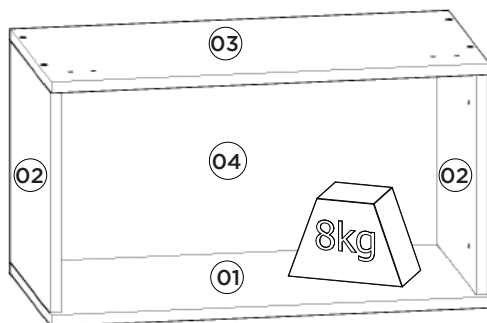
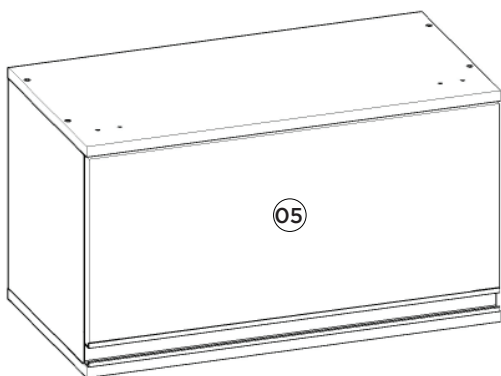

Pesos máximos recomendados com carga distribuída
Peso máximo recomendado con la carga distribuída
Recommended maximum weight with distributed load.

Requisitos para montagem
Requisitos para la montaje
Assembly Requirements

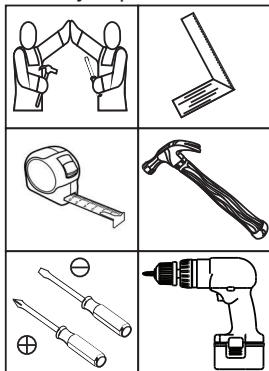

Imagens meramente ilustrativas
Imágenes meramente ilustrativas
Images for illustration only

AVISO

Para limpeza de seu móvel, use uma flanela seca ou umedecida, e não utilize produtos químicos que possam danificar seu produto.

SISTEMA DE MONTAGEM

O sistema de montagem dos produtos, funciona de acordo com a ordem crescente dos números indicados no desenho. Ex: 01, 02, 03, 04... até a conclusão da montagem.

ADVERTENCIA

Para limpieza de su móvil, use una franela seca o húmeda, y no utilice productos químicos que puedan dañar su producto.

SISTEMA DE MONTAJE

El sistema de montaje de los productos funciona de acuerdo con el orden creciente de los números indicados en el dibujo. Ej.: 01, 02, 03, 04... hasta la conclusión del montaje.

NOTICE

To clean your furniture, use a dry or wet cloth, and do not use chemicals that may damage your product.

ASSEMBLY SYSTEM

The products' assembly system works according to the increasing order of the indicated numbers. For example: 01, 02, 03, 04 ... to the end of the assembly.

1º

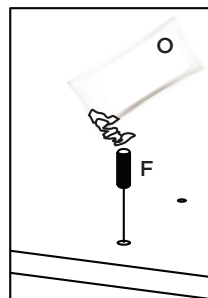
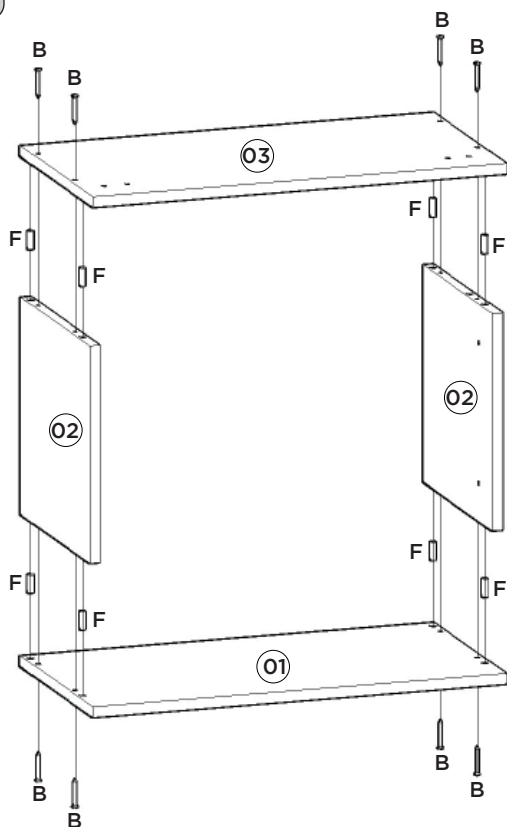

Utilizar o sachê de cola (O)
em todas as cavilhas (F)
do produto.

Con el pegamento sobre (O)
en todos los pernos (F)
producto.

Use the glue sachet (O) on all
the pegs (F) of the product.

2º

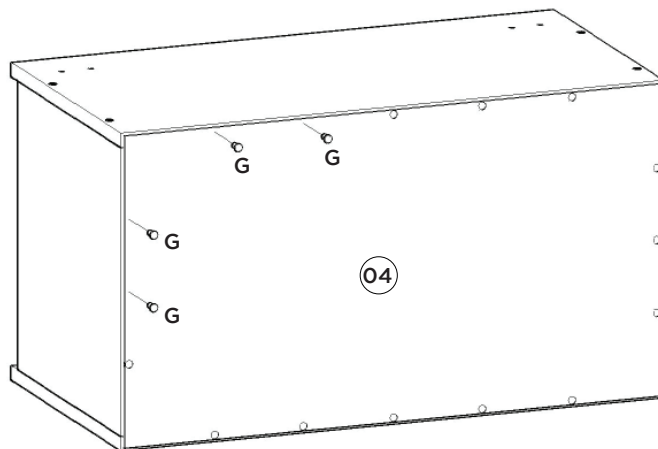

3º

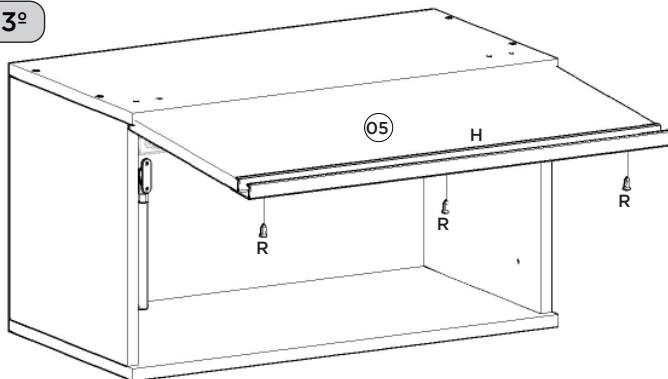

Video: Instalar e regular Dobradiças

Video: Instale y ajuste las bisagras

Video: Install and adjust hinges



Somente para (C77-139)

Solo para (C77-139)

Only for (C77-139)

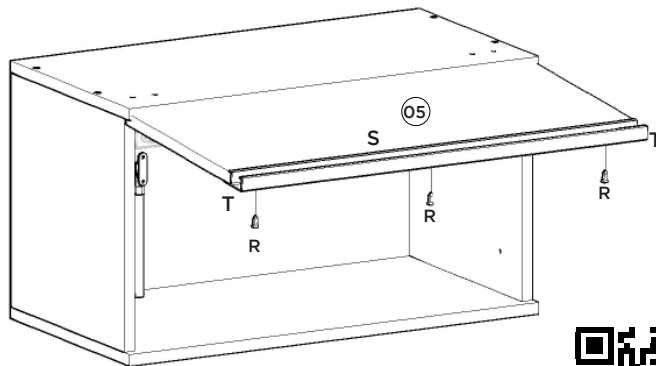
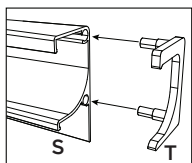

Video: Dicas para instalar o Kit Pistão à Gás

Video: Consejos para instalar el kit de pistón de gas



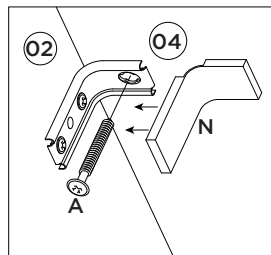
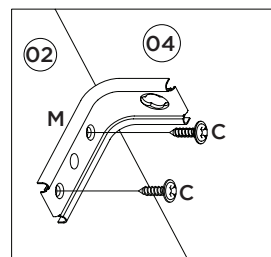
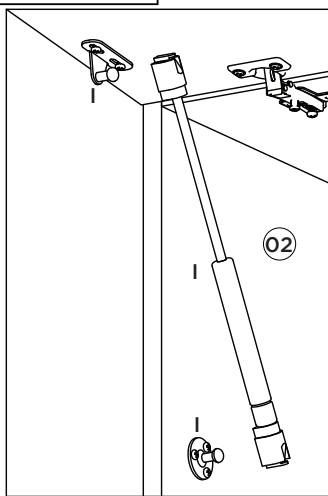
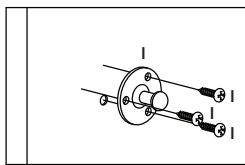
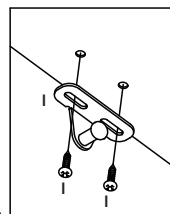
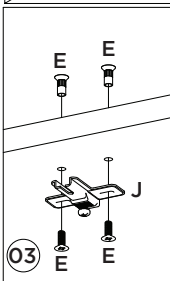
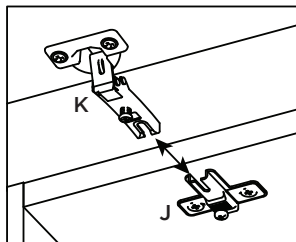
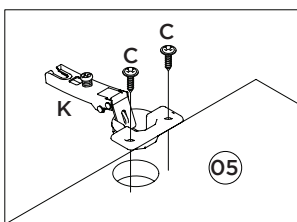







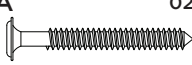

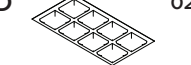
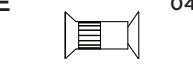

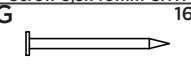
Video: Tips for installing the Gas Piston Kit

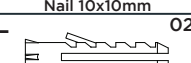

Lista de Peças | Lista de piezas | List of parts

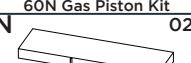
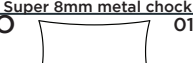
Item	Caixa Caja Box	Qtd Ctd Qty	Descrição Descripción Description	Medidas (mm) Dimensions (mm) Size (measurements) (mm)
01	1/1	01	Base Base Base	600x310x15
02	1/1	02	Lateral Direita Esquerda Lateral Derecha Izquierda Right Side Left	307x295x15
03	1/1	01	Tampo Tapa Top	600x310x15
04	1/1	01	Fundo Fondo Bottom	592x331x3
05	1/1	01	Porta Basculante Puerta Basculante Basculating Door	595x274x15
05	1/1	01	Porta Basculante Puerta Basculante Basculating Door (Somente para C77-139)	595x728x15

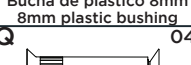
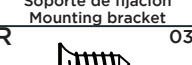
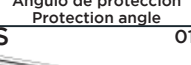
Ferragens | Herrajes | Hardware

A	02x	B	08x	C	08x	D	02x	E	04x
									
Parafuso 5,0x50mm FLA. Tornillo 5,0x50mm FLA. Screw 5,0x50mm FLA.		Parafuso 3,5x40mm CHT. Tornillo 3,5x40mm CHT. Screw 3,5x40mm CHT.		Parafuso 3,5x14mm FLA. Tornillo 3,5x14mm FLA. Screw 3,5x14mm FLA.		Batente PVC para Porta Parada de PVC para Puerta PVC Door Stop		Parafuso União 15mm Tornillo Unión 15mm Union Screw 15mm	
F	08x	G	16x	H	01x	I	01x	J	02x
									
Cavilha 8x25mm Cinta 8x25mm Dowel 8x25mm		Prego 10x10mm Clavo 10x10mm Nail 10x10mm		Puxador Alum. MOV 595mm Tirador Alum. MOV 595mm Handle Alum. MOV 595mm		Kit Pistão a Gás 60N Kit Pistón a Gas 60N 60N Gas Piston Kit		Calço metal Super Alto 8mm Calzado metálico Super Alto 8mm Super 8mm metal chock	
K	02x	L	02x	M	02x	N	02x	O	01x
									
Dobradiça metal 35mm Alta Bisagras metálicas 35mm Alta Metal hinge 35mm High		Bucha plástica 8mm Bucha de plástico 8mm 8mm plastic bushing		Suporte de fixação Soporte de fijación Mounting bracket		Proteção para cantoneira Ángulo de protección Protection angle		Sachê de cola Bolsa de pegamento Glue bag	
P	08x	Q	04x	R	03x	S	01x	T	01x
									
Adesivo tapa parafuso 10mm Adhesivo tapón de tornillo 10mm Bolt cover adhesive 10mm		Parafuso União 30mm Tornillo Unión 30mm Union Screw 30mm		Parafuso 3,5x12mm CHT. Tornillo 3,5x12mm CHT. Screw 3,5x12mm CHT.		Puxador MOV4083 - 591mm Tirador MOV4083 - 591mm MOV4083 - 591mm Handle		Kit Ponteira Plástica MOV4083 Kit de punta de plástico MOV4083 Plastic Tip Kit MOV4083	

Somente para (C77-139)

Solo para (C77-139)

Only for (C77-139)



O parafuso (Q) deve ser usada somente quando este módulo for acoplado a outro módulo componível Henn.



El tornillo (Q) se debe utilizar sólo cuando el módulo está conectado a otro módulo componible Henn.



The screw (Q) should be used only when this module is attached to another Henn modular module.

RECOMENDAÇÃO

Para fixar o móvel na parede usar o suporte de fixação (M), o parafuso 3,5x14mm FLA (C), a Bucha 8mm (L) e o parafuso 5,0x50mm FLA (A).

RECOMENDACIÓN

Para conectar el móvil a la pared con el soporte (M), tornillo 3,5 x14mm FLA (C), el casquillo de 8 mm (L) y el 5,0 x50mm tornillo FLA (A).

RECOMMENDATION

To fix the furniture to the wall use the fixing bracket (M), the 3.5x14mm FLA (C) screw, the 8mm bushing (L) and the 5.0x50mm FLA (A).

BALÇÃO 2 PORTAS 600MM CONNECT | BALCÓN 2 PUERTAS 600MM CONNECT | BALCONY 2 DOORS 600MM CONNECT

C78-35 Duna/Cristal
C78-42 Fendi
C78-139 Off White

Requisitos para montagem
Requisitos para la montaje
Assembly Requirements

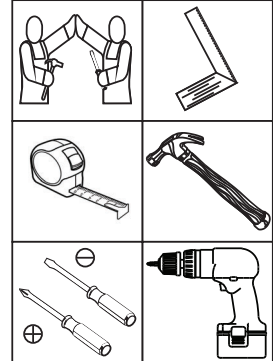

Imagens meramente ilustrativas, não acompanha o produto.
Imágenes ilustrativas, no incluidas con el producto.
Illustrative images, not included with the product.

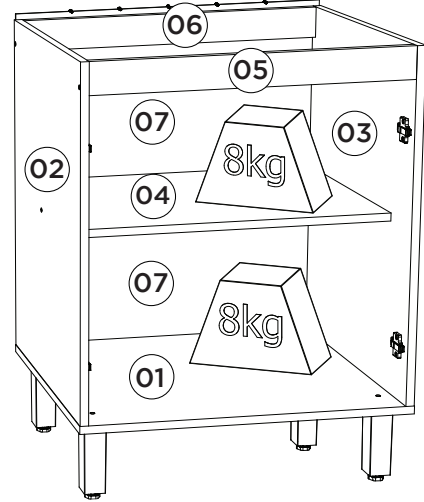
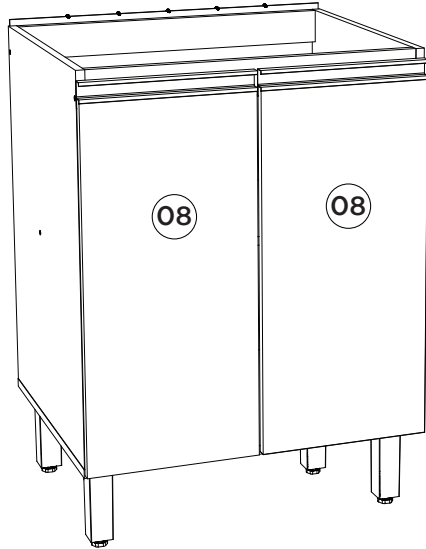

Pesos máximos recomendados com carga distribuída
Peso máximo recomendado con la carga distribuida
Recommended maximum weights with evenly distributed.

Lista de Peças | Lista de piezas | List of parts

Item	Caixa Caja Box	Qtd Ctd Qty	Descrição Descripción Description	Medidas (mm) Dimensions (mm) Size (measurements) (mm)
01	1/1	01	Base Base Base	600x490x15
02	1/1	01	Lateral esquerda Lateral izquierda Left side	660x490x15
03	1/1	01	Lateral direita Lateral derecha Right side	660x490x15
04	1/1	01	Prateleira Estante Shelf	568x400x15
05	1/1	01	Travessa frontal Travesaño frontal Front crossbar	568x60x15
06	1/1	01	Travessa traseira Travesaño trasero Rear bumper	568x60x15
07	1/1	02	Fundo Fondo Bottom	592x341x3
08	1/1	02	Porta Puerta Door	625x296x15
08	1/1	02	Porta Puerta Door (Somente para C78-139)	629x296x15

AVISO
Para limpeza de seu móvel, use uma flanela seca ou umedecida, e não utilize produtos químicos que possam danificar seu produto.

SISTEMA DE MONTAGEM
O sistema de montagem dos produtos, funciona de acordo com a ordem crescente dos números indicados no desenho. Ex: 01, 02, 03, 04... até a conclusão da montagem.

ASSISTÊNCIA TÉCNICA
Para solicitação de Assistência Técnica você consumidor deverá entrar em contato com o Lojista o qual você realizou a compra deste produto e solicitar a assistência técnica das peças avariadas. A garantia abrange todas as peças, partes e componentes que eventualmente venham apresentar defeito de fabricação no prazo de 03 (três) meses, contando a partir da entrega do produto ao consumidor, mediante nota fiscal de compra. Se houver qualquer alteração na estrutura do produto ou ocorrer defeito por negligência do montador/consumidor em relação a instrução de montagem e manuseio, não será fornecido assistência técnica gratuita.

ADVERTENCIA
Para limpieza de su móvil, use una flanela seca o húmeda, y no utilice productos químicos que puedan dañar su producto.

SISTEMA DE MONTAJE
El sistema de montaje de los productos funciona de acuerdo con el orden creciente de los números indicados en el dibujo. Ej: 01, 02, 03, 04... hasta la conclusión del montaje.

ASISTENCIA TÉCNICA
Para solicitar Asistencia Técnica, el consumidor debe comunicarse con el Comercio que usted realizó la compra de este producto y solicita asistencia técnica para las partes dañadas. La garantía cubre todas las partes, piezas y componentes que eventualmente puedan presentar defecto de fabricación en el plazo de 03 (tres) meses, contados a partir de la entrega del producto al consumidor, mediante factura de compra. Si se produce algún cambio en la estructura del producto o se produce un defecto por negligencia del montador/consumidor en relación con las instrucciones de montaje y manipulación, no se prestará asistencia técnica gratuita.

NOTICE
To clean your furniture, use a dry or wet cloth, and do not use chemicals that may damage your product.

ASSEMBLY SYSTEM
The products' assembly system works according to the increasing order of the indicated numbers. For example: 01, 02, 03, 04 ... to the end of the assembly.

TECHNICAL ASSISTANCE
To request Technical Assistance, the consumer must contact the retailer from whom you purchased this product and request technical assistance for the damaged parts. The warranty covers all parts, parts and components that may eventually present a manufacturing defect within a period of 03 (three) months, counting from the delivery of the product to the consumer, by means of a purchase invoice. If there is any change in the structure of the product or defect occurs due to negligence of the assembler/consumer in relation to the assembly and handling instruction, free technical assistance will not be provided.

Ferragens | Herrajes | Hardware

A 04x Parafuso 7,0x40mm CHT. Tornillo 7,0x40mm CHT. Screw 7,0x40mm CHT.	B 01x Parafuso 5,0x50mm FLA. Tornillo 5,0x50mm FLA. Screw 5,0x50mm FLA.	C 02x Parafuso 4,5x50mm CHT. Tornillo 4,5x50mm CHT. Screw 4,5x50mm CHT.	D 10x Parafuso 3,5x40mm CHT. Tornillo 3,5x40mm CHT. Screw 3,5x40mm CHT.	E 26x Parafuso 3,5x14mm FLA. Tornillo 3,5x14mm FLA. Screw 3,5x14mm FLA.	F 09x Parafuso 3,5x12mm CHT. Tornillo 3,5x12mm CHT. Screw 3,5x12mm CHT.	G 04x Parafuso União 30mm Tornillo Unión 30mm Union Screw 30mm	H 12x Cavilha 8x25mm Cinta 8x25mm Dowel 8x25mm
I 22x Prego 10x10mm Clavo 10x10mm Nail 10x10mm	J 05x Fixador de fundos Fijador de fondos Bottom fixer	K 04x Cantoneira plástica Cantonera plástica Plastic angle brackets	L 04x Pé 145mm x 42mm Pie 145mm x 42mm Foot 145mm x 42mm	M 02x Puxador MOV 296mm Tirador MOV 296mm MOV 296mm Handle	N 04x Calço metal médio 0mm Calzón de metal medio 0mm Shim metal middle 0mm	O 04x Dobradilha metal 35mm Bisagra de metal 35mm Metal hinge 35mm Colo Baixo Metal hincage 35mm Colo Low	P 04x Batente PVC para Porta Parada de PVC para Puerta PVC Door Stop
Q 01x Buchas de plástico 8mm 8mm plastic bushing	R 01x Suporte de fixação Soporte de fijación Mounting bracket	S 01x Proteção para cantoneira Ángulo de protección Protection angle	T 02x Giz de correção Tiza de corrección Chalk of correction	U 01x Sachê de cola Bolsa de pegamento Glue bag	V 10x Adesivo tapa parafuso 10mm Adhesivo tapón de tornillo 10mm Bolt cover adhesive 10mm	W 04x Adesivo tapa parafuso 17mm Adhesivo tapón de tornillo 17mm Bolt cover adhesive 17mm	X 02x Puxador MOV4083 - 292mm Tirador MOV4083 - 292mm MOV4083 - 292mm Handle

O parafuso (G) deve ser usada somente quando este módulo for acoplado a outro módulo componível Henn.

El tornillo (G) se debe utilizar sólo cuando el módulo está conectado a otro módulo componible Henn.

The screw (G) should be used only when this module is attached to another Henn modular module.

RECOMENDAÇÃO

Para fixar o móvel na parede usar o suporte de fixação (R), o parafuso 3,5x14mm FLA (E), a Bucha 8mm (Q) e o parafuso 5,0x50mm FLA (B).

RECOMENDACIÓN

Para conectar el móvil a la pared con el soporte (R), tornillo 3,5 x14mm FLA (E), el casquillo de 8 mm (Q) y el 5,0 x50mm tornillo FLA (B).

RECOMMENDATION

To fix the furniture to the wall use the mounting bracket (R), the 3.5x14mm FLA (E) screw, the 8mm bushing (Q) and the 5.0x50mm FLA (B).

Kit Ponta Plástica MOV4083
Kit de ponta de plástico MOV4083
Plastic Tip Kit MOV4083

Somente para (C78-139)
Solo para (C78-139)
Only for (C78-139)

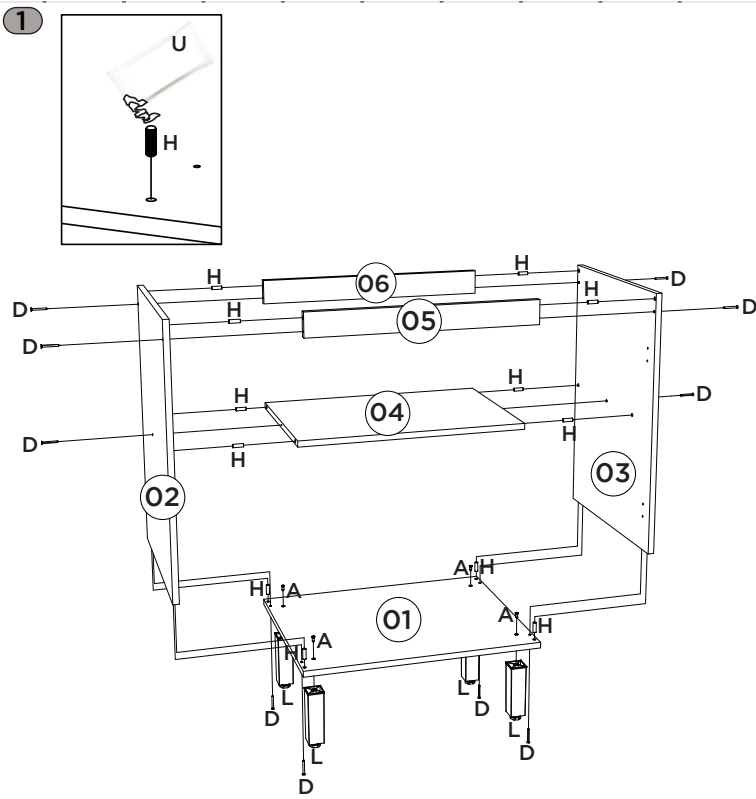

2

Esse tampo é opcional e é vendido separadamente (C903-33).

Esta vez es opcional y se vende por separado (C903-33).

This top is optional and is sold separately (C903-33).

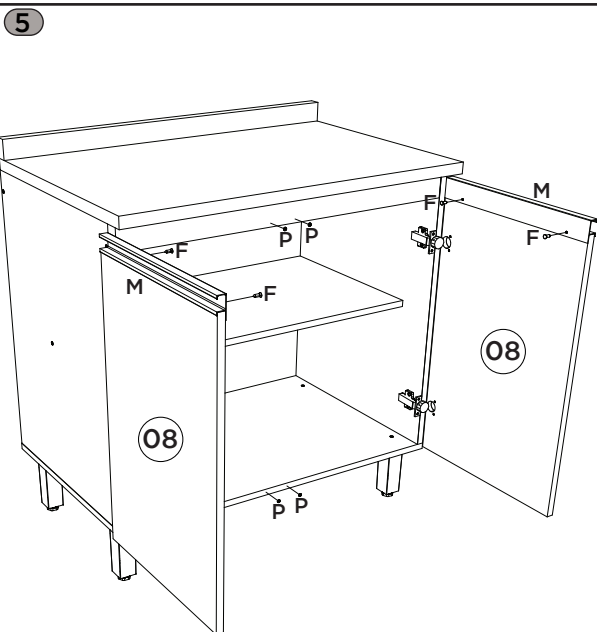
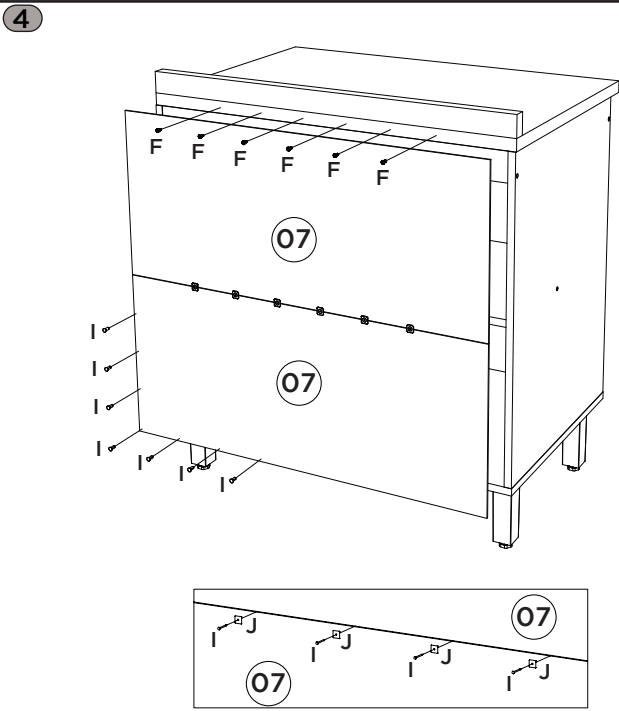
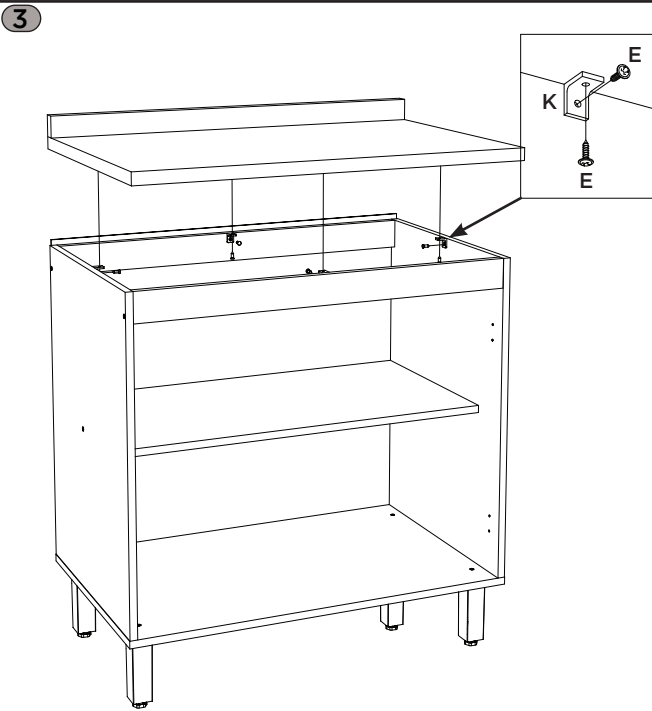
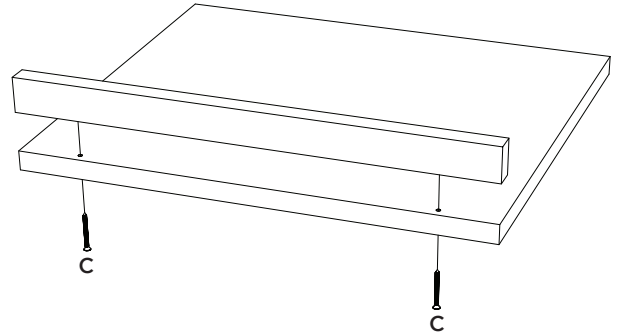

!

Somente para (C78-139)

Solo para (C78-139)

Only for (C78-139)

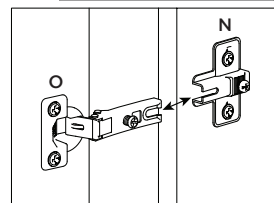
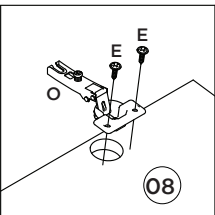
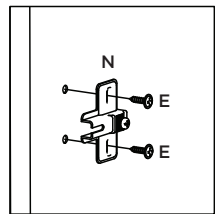
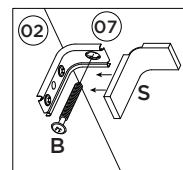
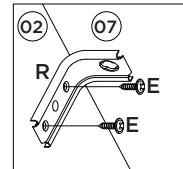
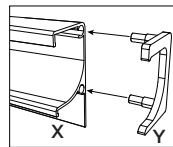

Video: Instalar e regular Dobradiças

Video: Instale y ajuste las bisagras

Video: Install and adjust hinges

HENNInd. e Com. de Móveis Henn
Mondaí - SC - Brasil

☎+55 49 3674.3500

📧@moveishenn
www.henn.com.br**INSTRUÇÕES DE MONTAGEM**INSTRUCCIONES DE MONTAJE
ASSEMBLY INSTRUCTIONS**BALÇÃO PARA FORNO DE EMBUTIR CONNECT | BALCÓN PARA HORNO EMPOTRADO CONNECT | BALCONY FOR BUILT-IN OVEN CONNECT**

Referência/Cor

-
- C85-23 - Duna
-
-
- C85-35 - Duna/Cristal
-
-
- C85-139 Off White

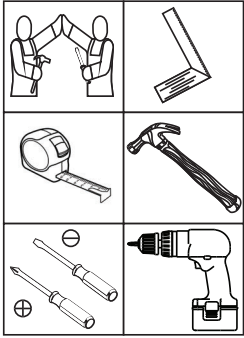
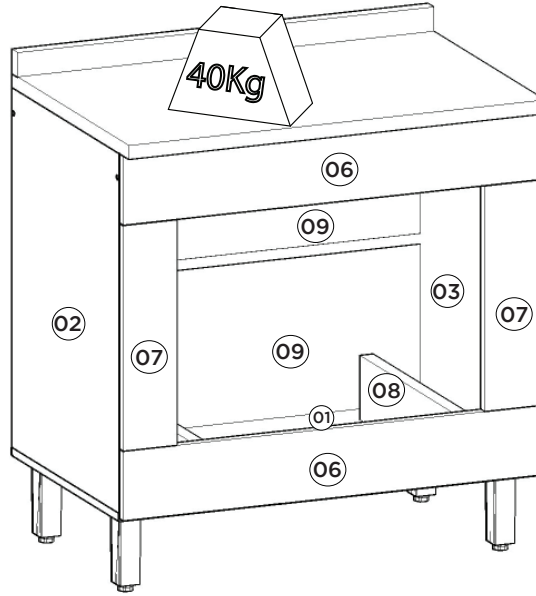
Requisitos para montagem
Requisitor para la montaje
Assembly RequirementsImagens meramente ilustrativas
Imágenes meramente ilustrativas
Images for illustration onlyPesos máximos recomendados com carga distribuída
Peso máximo recomendado con la carga distribuida
Recommended maximum weights with evenly distributed.

AVISO

Para limpeza de seu móvel, use uma flanela seca ou umedecida, e não utilize produtos químicos que possam danificar seu produto.

SISTEMA DE MONTAGEM

O sistema de montagem dos produtos, funciona de acordo com a ordem crescente dos números indicados no desenho. Ex: 01, 02, 03, 04... até a conclusão da montagem.

ADVERTENCIA

Para limpieza de su móvil, use una flanela seca o húmeda, y no utilice productos químicos que puedan dañar su producto.

SISTEMA DE MONTAJE

El sistema de montaje de los productos funciona de acuerdo con el orden creciente de los números indicados en el dibujo. Ej.: 01, 02, 03, 04... hasta la conclusión del montaje.

NOTICE

To clean your furniture, use a dry or wet cloth, and do not use chemicals that may damage your product.

ASSEMBLY SYSTEM

The products' assembly system works according to the increasing order of the indicated numbers. For example: 01, 02, 03, 04 ... to the end of the assembly.

Lista de Peças | Lista de piezas | List of parts

Item	Caixa Caja Box	Qtd Ctd Qty	Descrição Descripción Description	Medidas (mm) Dimensions (mm) Size (measurements) (mm)
01	1/1	01	Base Base Base	800x490x15
02	1/1	01	Lateral esquerda Lateral izquierda Left side	660x490x15
03	1/1	01	Lateral direita Lateral derecha Right side	660x490x15
04	1/1	01	Travessa frontal Travesaño frontal Front crossbar	769x60x15
05	1/1	01	Travessa traseira Travesaño trasero Rear bumper	769x60x15
06	1/1	02	Vista Frontal Maior Vista frontal más grande Larger Front View	798x134x15
07	1/1	02	Vista Lateral Vista lateral Side view	402x104x15
08	1/1	02	Travessa Sustentação Placa de soporte Support Plate	420x124x25
09	1/1	02	Fundo Fondo Bottom	793x312x3

Ferragens | Herrajes | Hardware

A Parafuso 7,0x40mm CHT. Tornillo 7,0x40mm CHT. Screw 7,0x40mm CHT.	B Parafuso 5,0x50mm FLA. Tornillo 5,0x50mm FLA. Screw 5,0x50mm FLA.	C Parafuso 4,5x50mm CHT. Tornillo 4,5x50mm CHT. Screw 4,5x50mm CHT.	D Parafuso 3,5x40mm CHT. Tornillo 3,5x40mm CHT. Screw 3,5x40mm CHT.	E Parafuso 3,5x14mm FLA. Tornillo 3,5x14mm FLA. Screw 3,5x14mm FLA.	F Parafuso 3,5x12mm CHT. Tornillo 3,5x12mm CHT. Screw 3,5x12mm CHT.	G Parafuso União 30mm Tornillo Unión 30mm Union Screw 30mm	H Cavilha 8x25mm Cinta 8x25mm Dowel 8x25mm
I Prego 10x10mm Clavo 10x10mm Nail 10x10mm	J Parafuso 4,0x25mm CHT. Tornillo 4,0x25mm CHT. Screw 4,0x25mm CHT.	K Cantoneira plástica Cantонера plástica Plastic angle brackets	L Pé 145mm x 42mm Pie 145mm x 42mm Foot 145mm x 42mm	M Conector de Montagem Conector de montaje Mounting Connector	N Suporte metal Soporte metálico Metal support	O Perfil "H" 785mm Perfil "H" 785mm Profile "H" 785mm	P Adesivo tapa parafuso 10mm Adhesivo tapón de tornillo 10mm Bolt cover adhesive 10mm
Q Buchsa plástica 8mm Bucha de plástico 8mm 8mm plastic bushing	R Suporte de fixação Soporte de fijación Mounting bracket	S Proteção para cantoneira Ángulo de protección Protection angle	T Giz de correção Tiza de corrección Chalk of correction	U Sachê de cola Bolsa de pegamento Glue bag			

O parafuso (G) deve ser usada somente quando este módulo for acoplado a outro módulo componível Henn.

El tornillo (G) se debe utilizar sólo cuando el módulo está conectado a otro módulo componible Henn.

The screw (G) should be used only when this module is attached to another Henn modular module.

RECOMENDAÇÃO

Para fixar o móvel na parede usar o suporte de fixação (R), o parafuso 3,5x14mm FLA (E), a Buchsa 8mm (Q) e o parafuso 5,0x50mm FLA (B).

RECOMENDACIÓN

Para conectar el móvil a la pared con el soporte (R), tornillo 3,5 x14mm FLA (E), el casquillo de 8 mm (Q) y el 5,0 x50mm tornillo FLA (B).

RECOMMENDATION

To fix the furniture to the wall use the mounting bracket (R), the 3.5x14mm FLA (E) screw, the 8mm bushing (Q) and the 5.0x50mm FLA screw (B).

1º

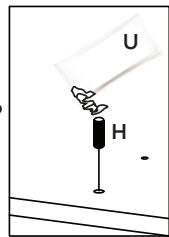
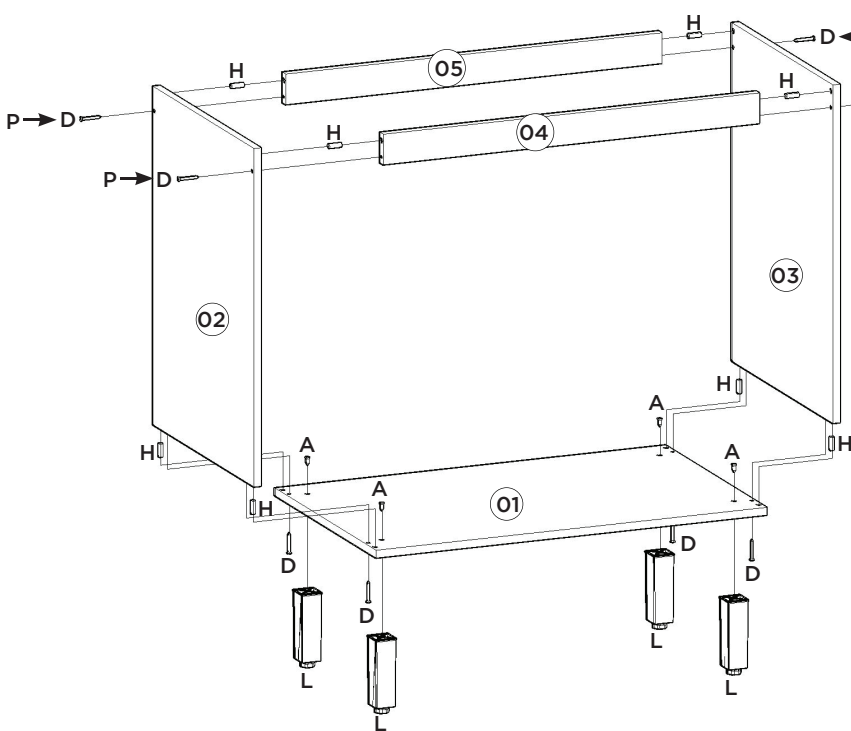

Utilizar o sachê de cola (U) em todas as cavilhas (H) do produto.

Con el pegamento sobre (U) en todos los pernos (H) producto.

Use the glue sachet (U) on all the pegs (H) of the product.

2º

Esse tampo é opcional e é vendido separadamente (C904-33).

Esta vez es opcional y se vende por separado (C904-33).

This top is optional and is sold separately (C904-33).

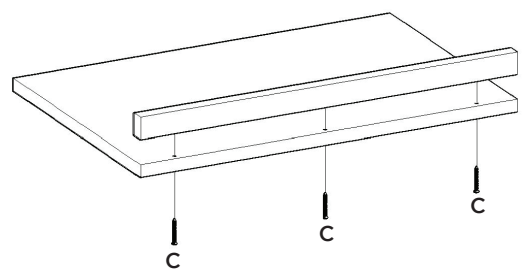

2º

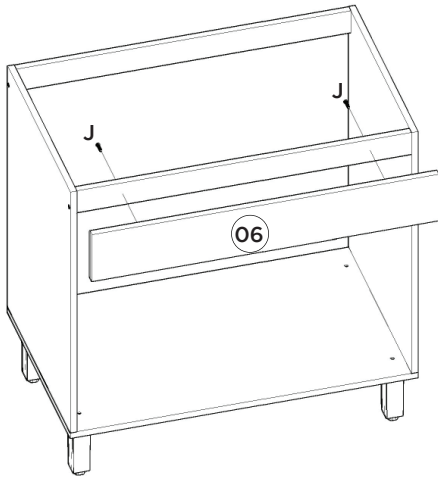

3º

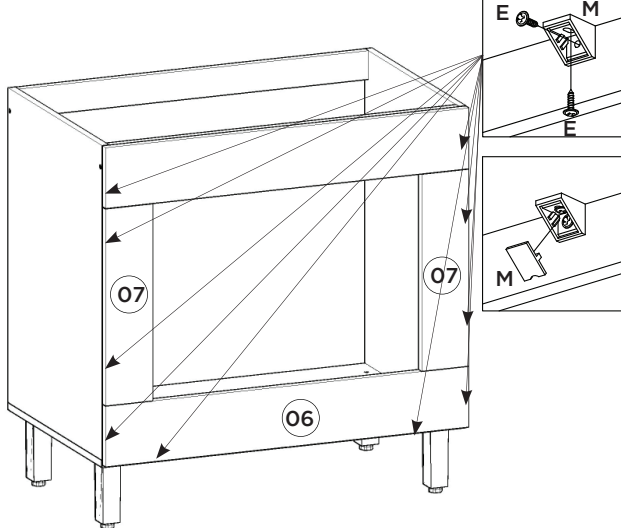

4º

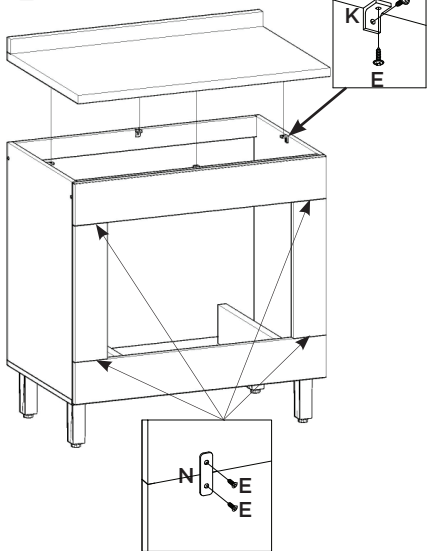

5º

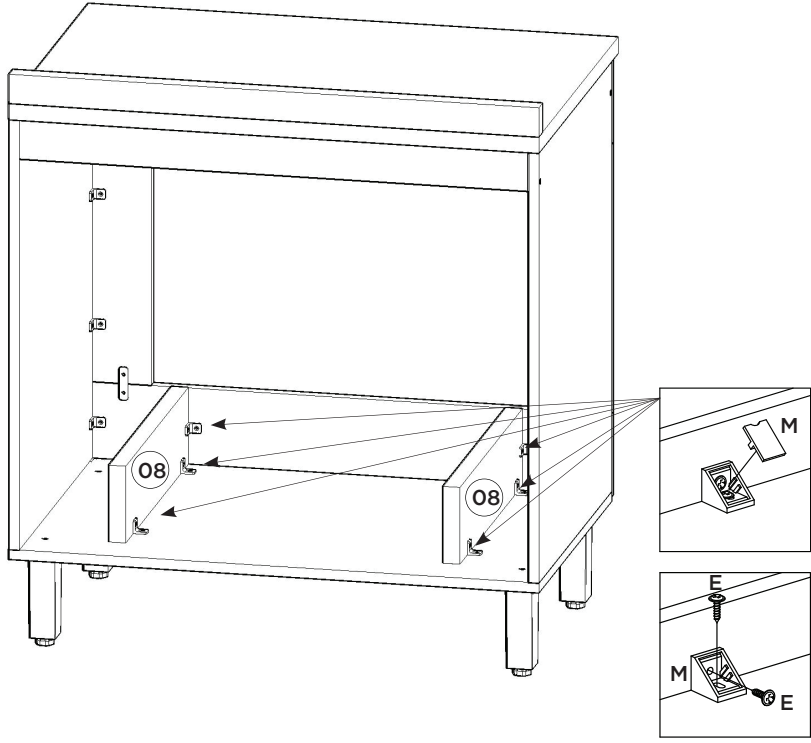

6º



ATENÇÃO: Por questão de segurança, recomendamos a não utilização do Fundo (12) caso o espaço seja utilizado por forno embutido, dessa forma, haverá melhor propagação do calor, evitando danos em seu móvel.

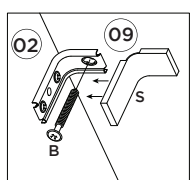
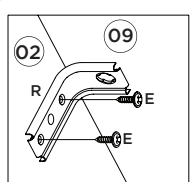
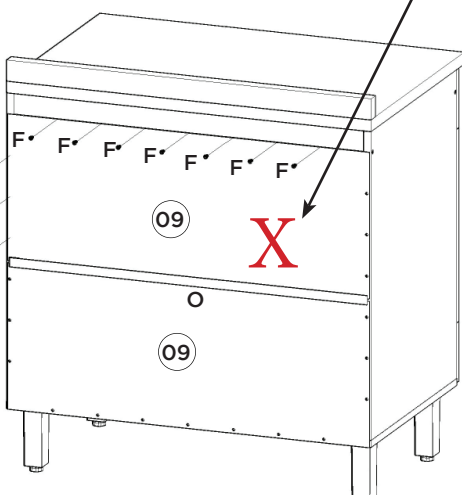

HENNInd. e Com. de Móveis Henn
Mondai - SC - Brasil

☎ +55 49 3674.3500

📱 @moveishenn
www.henn.com.br**INSTRUÇÕES DE
MONTAGEM****INSTRUCCIONES DE MONTAJE
ASSEMBLY INSTRUCTIONS****Aéreo Micro-ondas 600mm Connect | Aire Microondas 600mm Connect |
Aerial Microwave 600mm Connect****Referência/Cor**

- C428-23 - Duna
 C428-139 - Off White

Requisitos para montagem
Requisitos para la montaje
Assembly Requirements

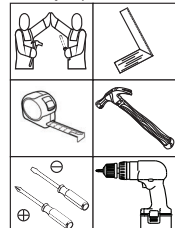

Imagens meramente ilustrativas, não
acompanha o produto.
Imágenes ilustrativas, no incluidas con
el producto.
Illustrative images, not included with
the product.

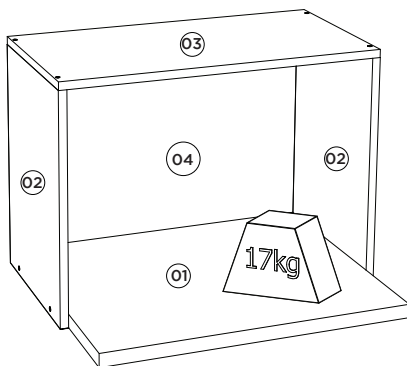

**Pesos máximos recomendados com carga distribuída
Peso máximo recomendado con la carga distribuída
Recommended maximum weight with distributed load.**

Lista de Peças | Lista de piezas | List of parts

Item	Caixa Caja Box	Qty Ctd Qty	Descrição Descripción Description	Medidas (mm) Dimensions (mm) Size (measurements) (mm)
01	1/1	01	Base Base Base	570x400x25
02	1/1	02	Lateral Direita Esquerda Lateral Derecha Izquierda Right Side Left	425x310x15
03	1/1	01	Tampo Tapa Top	600x310x15
04	1/1	01	Fundo Fondo Bottom	594x427x3

Ferragens | Herrajes | Hardware

A Parafuso 5,0x50mm FLA. Tornillo 5,0x50mm FLA. Screw 5,0x50mm FLA.	B Parafuso 3,5x40mm CHT. Tornillo 3,5x40mm CHT. Screw 3,5x40mm CHT.	C Prego 10x10mm Clavo 10x10mm Nail 10x10mm	D Parafuso 3,5x14mm FLA. Tornillo 3,5x14mm FLA. Screw 3,5x14mm FLA.	E Cavilha 8x25mm Cinta 8x25mm Dowel 8x25mm
F Bucha plástica 8mm Bucha de plástico 8mm 8mm plastic bushing	G Suporte de fixação Soporte de fijación Mounting bracket	H Proteção para cantoneira Ángulo de protección Protection angle	I Sachê de cola Bolsa de pegamento Glue bag	J Adesivo tapa parafuso 10mm Adhesivo tapón de tornillo 10mm Bolt cover adhesive 10mm
K Parafuso União 30mm Tornillo Unión 30mm Union Screw 30mm				

O parafuso (K) deve ser usada somente quando este módulo for acoplado a outro módulo componível Henn.

El tornillo (K) se debe utilizar sólo cuando el módulo está conectado a otro módulo componible Henn.

The screw (K) should be used only when this module is attached to another Henn modular module.

RECOMENDAÇÃO

Para fixar o móvel na parede usar o suporte de fixação (G), o parafuso 3,5x14mm FLA (D), a Bucha 8mm (F) e o parafuso 5,0x50mm FLA (A).

RECOMENDACIÓN

Para conectar el móvil a la pared con el soporte (G), tornillo 3,5 x14mm FLA (D), el casquillo de 8 mm (F) y el 5,0 x50mm tornillo FLA (A).

RECOMMENDATION

To fix the furniture to the wall use the fixing bracket (G), the 3.5x14mm FLA (D) screw, the 8mm bushing (F) and the 5.0x50mm FLA screw (A).

1

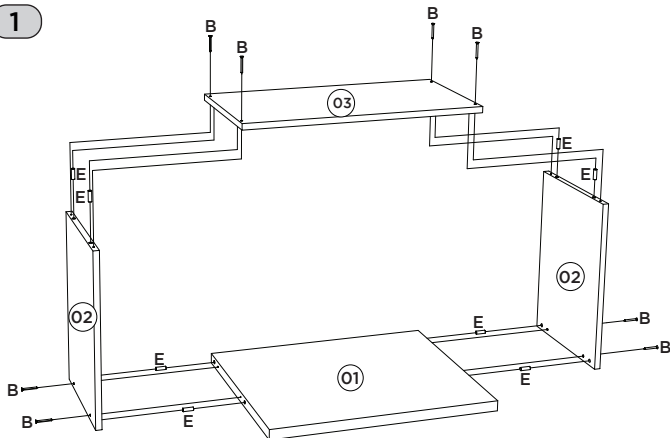

Utilizar o sachê de cola (I) em todas as cavilhas (E) do produto.

Con el pegamento sobre (U) en todos los pernos (E) producto.

Use the glue sachet (U) on all the pegs (E) of the product.

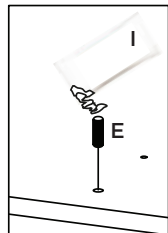

AVISO
Para limpeza de seu móvel, use uma flanela seca ou umedecida, e não utilize produtos químicos que possam danificar seu produto.

SISTEMA DE MONTAGEM
O sistema de montagem dos produtos, funciona de acordo com a ordem crescente dos números indicados no desenho. Ex: 01, 02, 03, 04... até a conclusão da montagem.

ASSISTÊNCIA TÉCNICA
Para solicitação de Assistência Técnica você consumidor deverá entrar em contato com o Lojista ou qual você realizou a compra deste produto e solicitar a assistência técnica das peças avariadas. A garantia abrange todas as peças, partes e componentes que eventualmente venham apresentar defeito de fabricação no prazo de 03 (três) meses, contando a partir da entrega do produto ao consumidor, mediante nota fiscal de compra. Se houver qualquer alteração na estrutura do produto ou ocorrer defeito por negligência do montador/consumidor em relação a instrução de montagem e manuseio, não será fornecido assistência técnica gratuita.

ADVERTENCIA
Para limpeza de su móvil, use una flanela seca o húmeda, y no utilice productos químicos que puedan dañar su producto.

SISTEMA DE MONTAJE
El sistema de montaje de los productos funciona de acuerdo con el orden creciente de los números indicados en el dibujo. Ej: 01, 02, 03, 04... hasta la conclusión del montaje.

ASISTENCIA TÉCNICA
Para solicitar Asistencia Técnica, el consumidor debe comunicarse con el Comercio que usted realizó la compra de este producto y solicita asistencia técnica para las partes dañadas. La garantía cubre todas las partes, piezas y componentes que eventualmente puedan presentar defecto de fabricación en el plazo de 03 (tres) meses, contados a partir de la entrega del producto al consumidor, mediante factura de compra. Si se produce algún cambio en la estructura del producto o se produce un defecto por negligencia del montador/consumidor en relación con las instrucciones de montaje y manipulación, no se prestará asistencia técnica gratuita.

NOTICE
To clean your furniture, use a dry or wet cloth, and do not use chemicals that may damage your product.

ASSEMBLY SYSTEM
The products' assembly system works according to the increasing order of the indicated numbers. For example: 01, 02, 03, 04 ... to the end of the assembly.

TECHNICAL ASSISTANCE
To request Technical Assistance, the consumer must contact the retailer from whom you purchased this product and request technical assistance for the damaged parts. The warranty covers all parts, parts and components that may eventually present a manufacturing defect within a period of 03 (three) months, counting from the delivery of the product to the consumer, by means of a purchase invoice. If there is any change in the structure of the product or defect occurs due to negligence of the assembler/consumer in relation to the assembly and handling instruction, free technical assistance will not be provided.

2

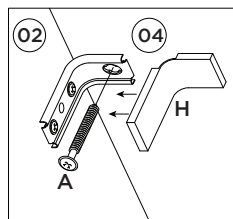
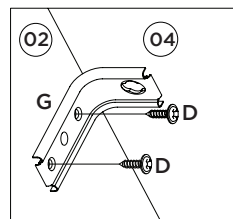
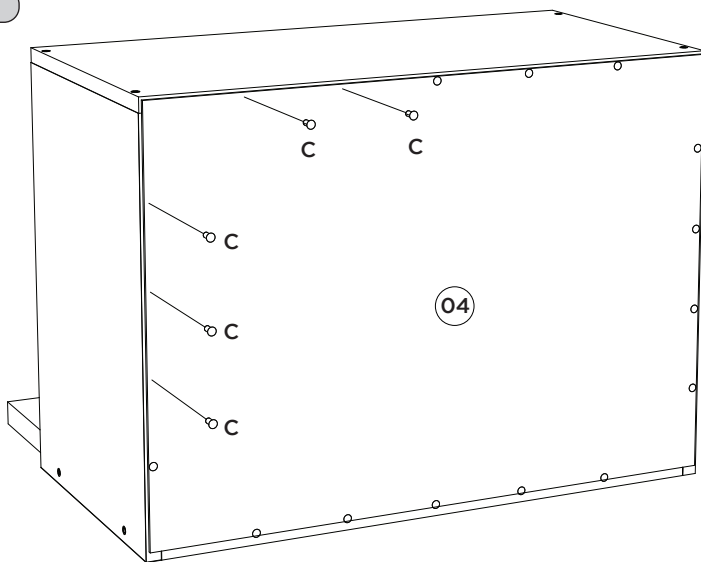

2

HENNInd. e Com. de Móveis Henn
Mondai - SC - Brasil

☎+55 49 3674.3500

📧📱@moveishenn
www.henn.com.br**INSTRUÇÕES DE MONTAGEM**INSTRUCCIONES DE MONTAJE
ASSEMBLY INSTRUCTIONS**Tampo para Balcão 600mm | Tablero para Balcón 600mm | Counter Top 600mm**

- C903-23 Duna
 C903-114 Calcare

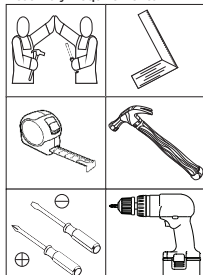
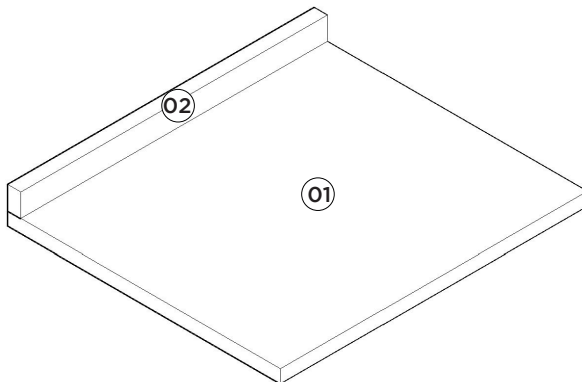
Requisitos para montagem
Requisitor para la montaje
Assembly RequirementsImagens meramente ilustrativas
Imágenes meramente ilustrativas
Images for illustration only**AVISO**

Para limpeza de seu móvel, use uma flanela seca ou umedecida, e não utilize produtos químicos que possam danificar seu produto.

SISTEMA DE MONTAGEM

O sistema de montagem dos produtos, funciona de acordo com a ordem crescente dos números indicados no desenho. Ex: 01, 02, 03, 04... até a conclusão da montagem.

ADVERTENCIA

Para limpieza de su móvil, use una franela seca o húmeda, y no utilice productos químicos que puedan dañar su producto.

SISTEMA DE MONTAJE

El sistema de montaje de los productos funciona de acuerdo con el orden creciente de los números indicados en el dibujo. Ej.: 01, 02, 03, 04... hasta la conclusión del montaje.

NOTICE

To clean your furniture, use a dry or wet cloth, and do not use chemicals that may damage your product.

ASSEMBLY SYSTEM

The products' assembly system works according to the increasing order of the indicated numbers. For example: 01, 02, 03, 04 ... to the end of the assembly.

Lista de Peças | Lista de piezas | List of parts

Item	Caixa Caja Box	Qtd Ctd Qty	Descrição Descripción Description	Medidas (mm) Dimensiones (mm) Size (measurements) (mm)
01	1/1	01	Tampo Tapa Top	600x533x25
02	1/1	01	Rodatampo Rodatampo Rodatampo	600x45x25

Ferragens | Herrajes | Hardware

A	02x	B	08x	C	04x
					
Parafuso 4,5x50mm CHT. Tornillo 4,5x50mm CHT. Screw 4,5x50mm CHT.		Parafuso 3,5x14mm FLA. Tornillo 3,5x14mm FLA. Screw 3,5x14mm FLA.		Cantoneira plástica Cantонера plástica Plastic angle brackets	

⚠ Estas ferragens constam no Pacote do respectivo Balcão.
Estos herrajes constan en el Paquete del respectivo Balcón.
These hardware are included in the Package of the respective Counter.

Esse tampo é opcional e é vendido separadamente

Esta vez es opcional y se vende por separado

This top is optional and is sold separately

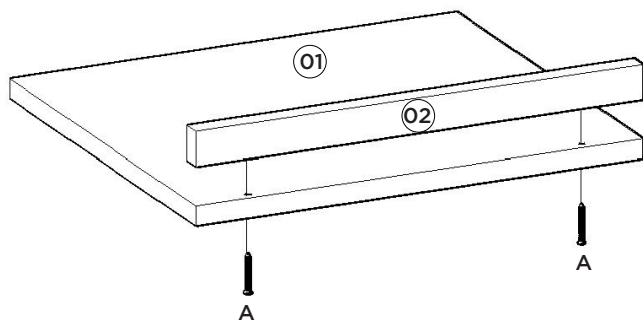

Exemplo de como fixar o Tampo no produto.

Ejemplo de la fijación de la tapa sobre el producto.

Example of fixing the lid on the product.

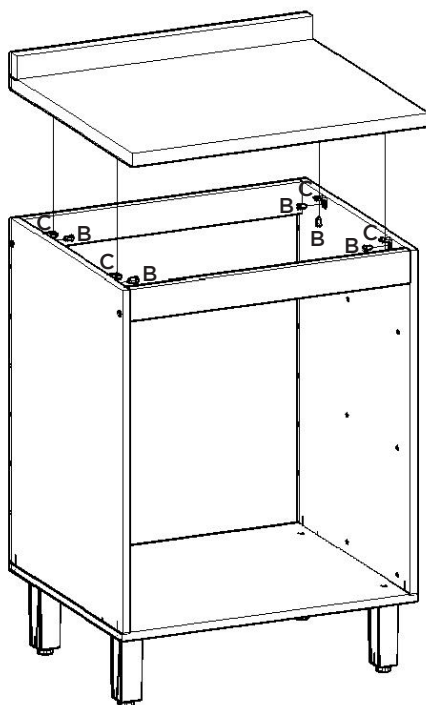

HENNInd. e Com. de Móveis Henn
Mondai - SC - Brasil

☎+55 49 3674.3500

📧@moveishenn
www.henn.com.br**INSTRUÇÕES DE MONTAGEM**INSTRUCCIONES DE MONTAJE
ASSEMBLY INSTRUCTIONS**Tampo Cooktop 800mm | Tampo Cooktop 800mm | Cooktop top 800mm**

- C908-23 Duna
- C908-33 Nero
- C908-114 Calcare

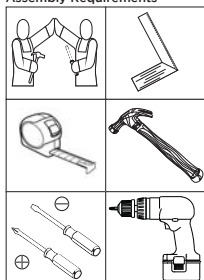
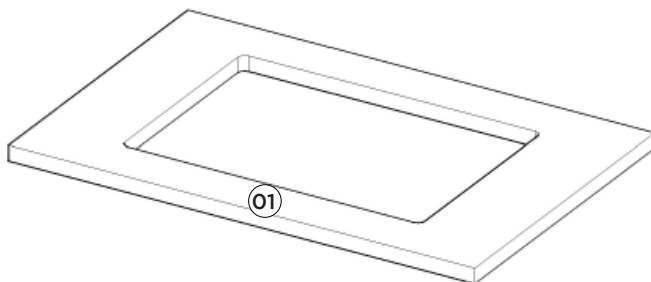
Requisitos para montagem
Requisitor para la montaje
Assembly RequirementsImagens meramente ilustrativas
Imágenes meramente ilustrativas
Images for illustration only**AVISO**

Para limpeza de seu móvel, use uma flanela seca ou umedecida, e não utilize produtos químicos que possam danificar seu produto.

SISTEMA DE MONTAGEM

O sistema de montagem dos produtos, funciona de acordo com a ordem crescente dos números indicados no desenho. Ex: 01, 02, 03, 04... até a conclusão da montagem.

ADVERTENCIA

Para limpieza de su móvil, use una franela seca o húmeda, y no utilice productos químicos que puedan dañar su producto.

SISTEMA DE MONTAJE

El sistema de montaje de los productos funciona de acuerdo con el orden creciente de los números indicados en el dibujo. Ej.: 01, 02, 03, 04... hasta la conclusión del montaje.

NOTICE

To clean your furniture, use a dry or wet cloth, and do not use chemicals that may damage your product.



ASSEMBLY SYSTEM

The products' assembly system works according to the increasing order of the indicated numbers. For example: 01, 02, 03, 04 ... to the end of the assembly.

Lista de Peças | Lista de piezas | List of parts

Item	Caixa Caja Box	Qty Ctd Qty	Descrição Descripción Description	Medidas (mm) Dimensions (mm) Size (measure- ments) (mm)
01	1/1	01	Tampo Tapa Top	800x533x25

Ferragens | Herrajes | Hardware

A		08x	B		04x
Parafuso 3,5x14mm FLA. Tornillo 3,5x14mm FLA. Screw 3,5x14mm FLA.			Cantoneira plástica Cantонера plástica Plastic angle brackets		

 Estas ferragens constam no Pacote do respectivo Balcão.
Estos herrajes constan en el Paquete del respectivo Balcón.
These hardware are included in the Package of the respective Counter.

Esse tampo é opcional e é vendido separadamente

Esta vez es opcional y se vende por separado

This top is optional and is sold separately

Exemplo de como fixar o Tampo Cooktop no produto.

Ejemplo de cómo fijar el Tablero Cooktop en el producto.

Example of how to secure the Cooktop Top to the product.

