

YOU WILL NEED

TU AURAS BESOIN DE | NECESITARÁ | VOCÊ VAI PRECISAR

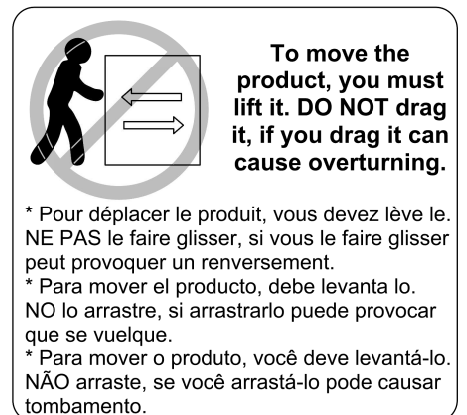
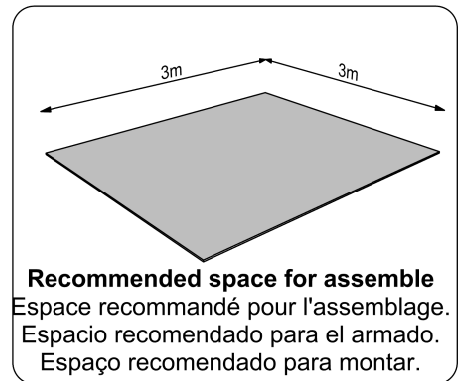
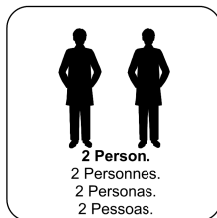
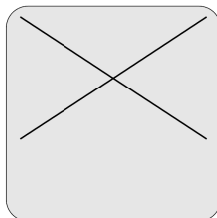
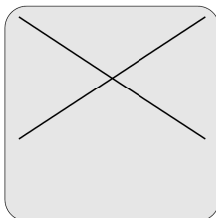
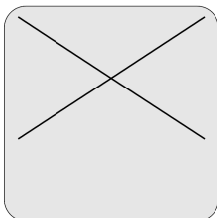
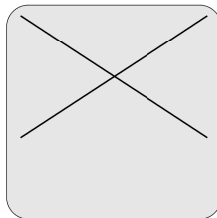
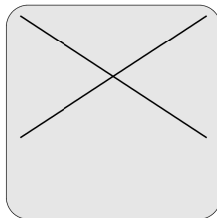
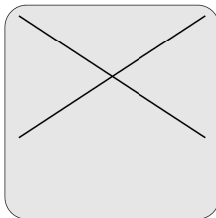
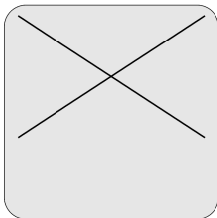
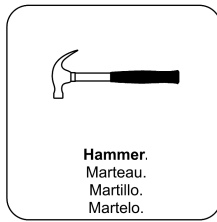
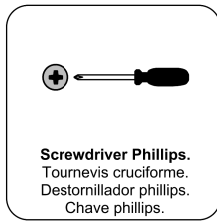
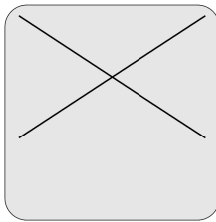
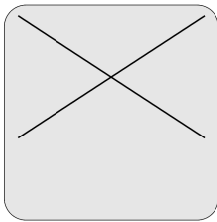

Tools not included

Outils non inclus | Herramientas no incluidas | Ferramentas não inclusas

PRE-ASSEMBLY - PRÉ-ASSEMBLAGE - PRE-ARMADO PRÉ-MONTAGEM

01 -

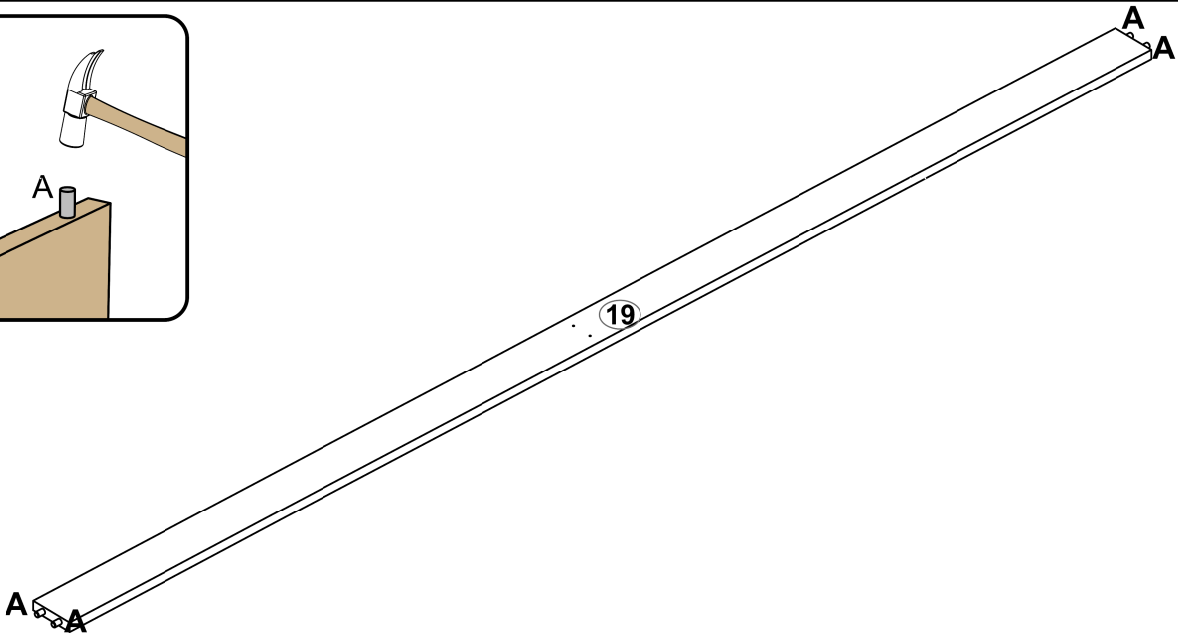
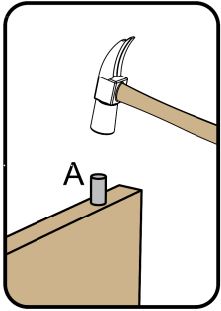

02 -

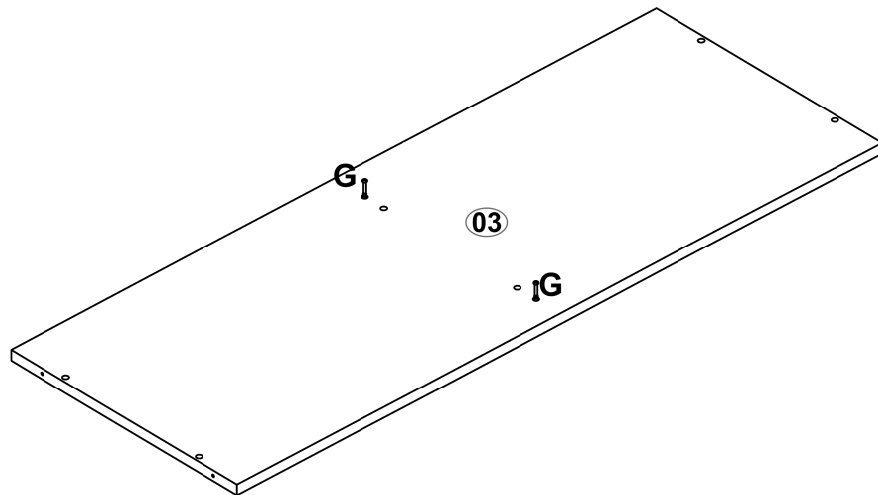
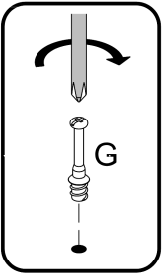

03 -

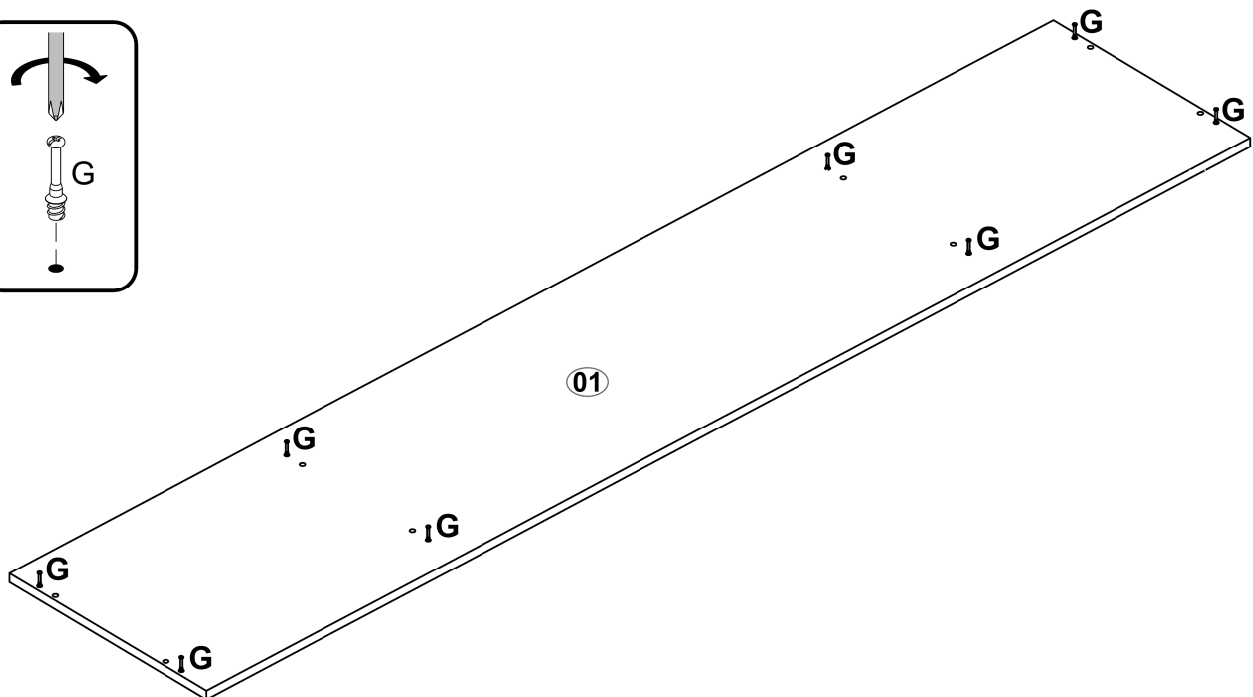
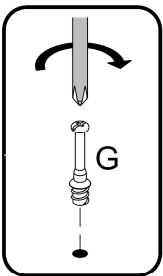

04 -

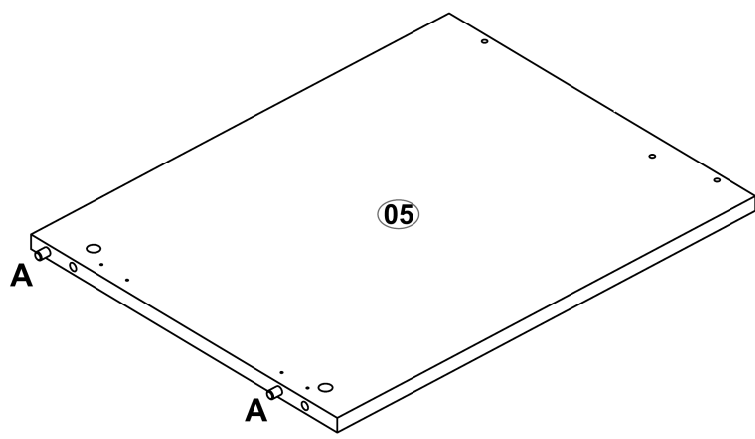
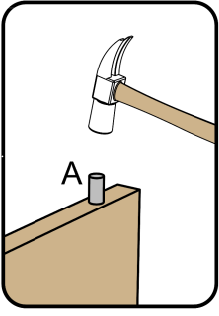

05 -

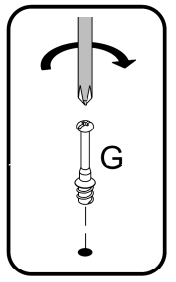
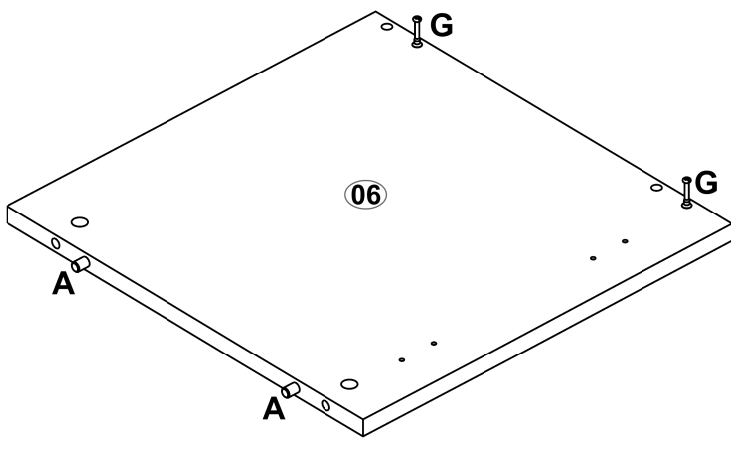
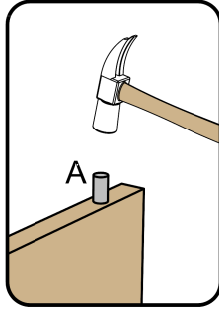

06 -

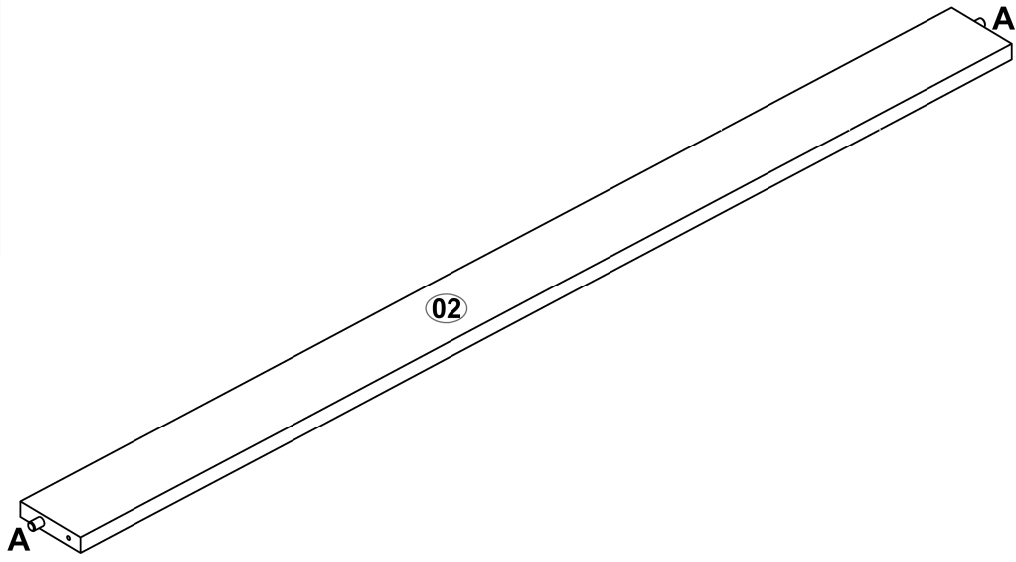
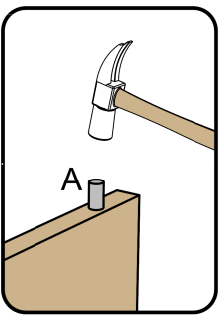

07 -

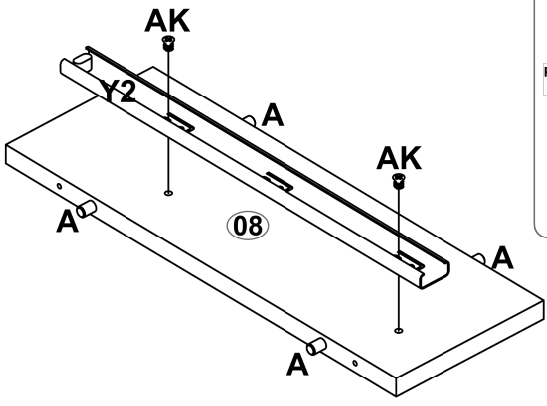
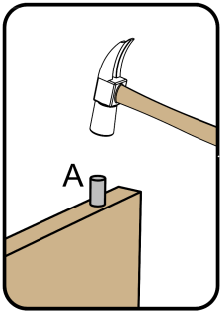

*SEPARATE THE TWO PARTS OF THE TELESCOPIC SLIDES FOLLOWING THE INSTRUCTIONS ILLUSTRATED BELOW TO ASSEMBLE.
 *POUR EFFECTUER L'ASSEMBLAGE, SÉPARER LES DEUX PARTIES DES DIAPOSITIVES TÉLESCOPIQUES COMME ILLUSTRÉ CI-DESSOUS
 *PARA EL ARMADO, SEPARA LAS DOS PARTES DE LAS CORREDERAS TELESCÓPICAS CONFORME LAS ILUSTRACIONES DE ABAJO.
 * SEPARA AS DUAS PARTES DA CORREDIÇA ANTES DE INICIAR AS MONTAGENS.

PULL / TIRER / TIRE / PUXE

PUSH DOWN AND PULL / APPUYER VERS LE BAS ET TIRER / PRESIONE PARA ABAJO Y TIRE / PRESSIONE PARA BAIXO E PUXE

PULL / TIRER / TIRE / PUXE

Y1 Y2

08 -

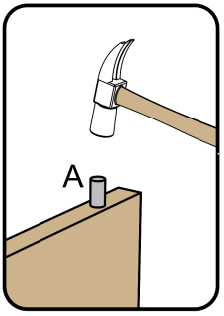

2x

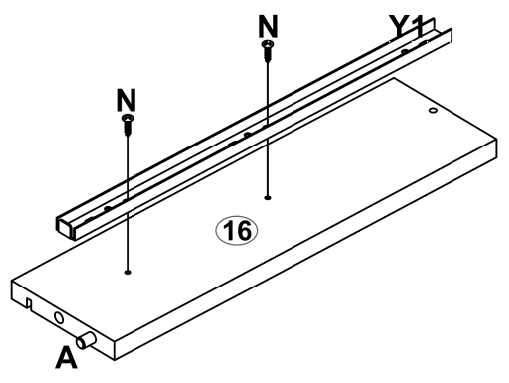
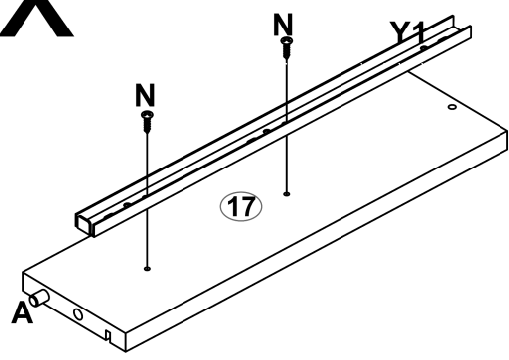

09 -

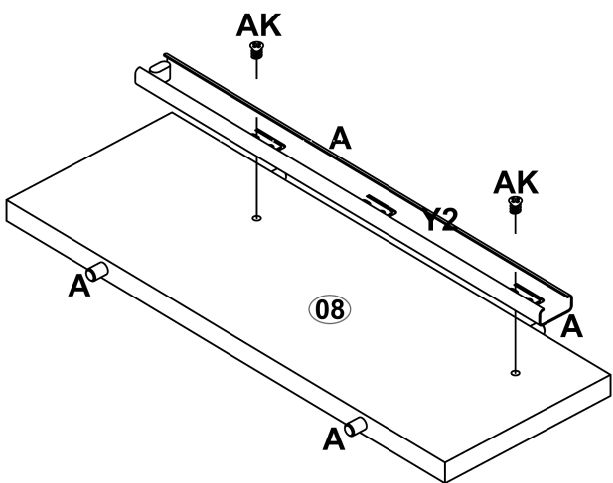
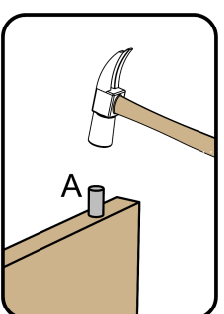

10 -

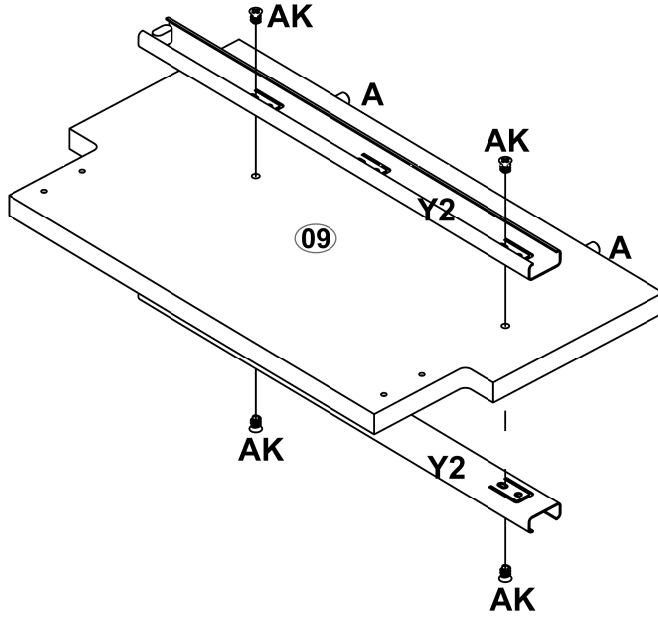
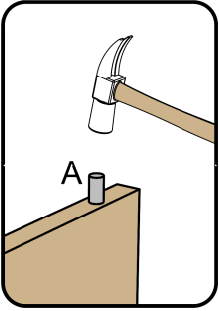

11 -

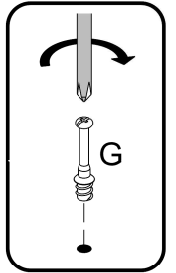
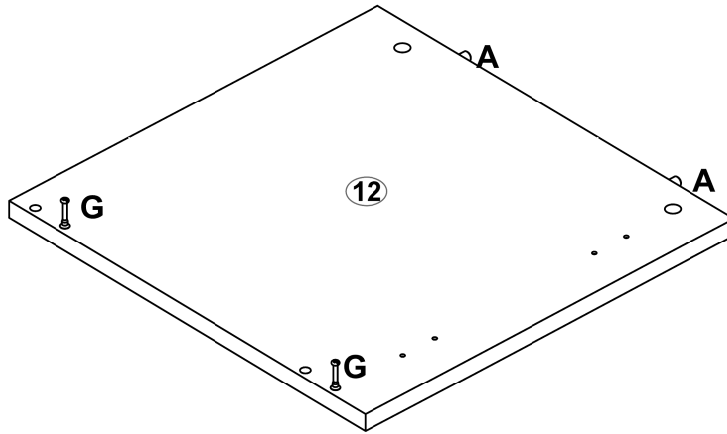
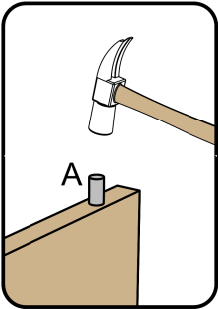

12 -

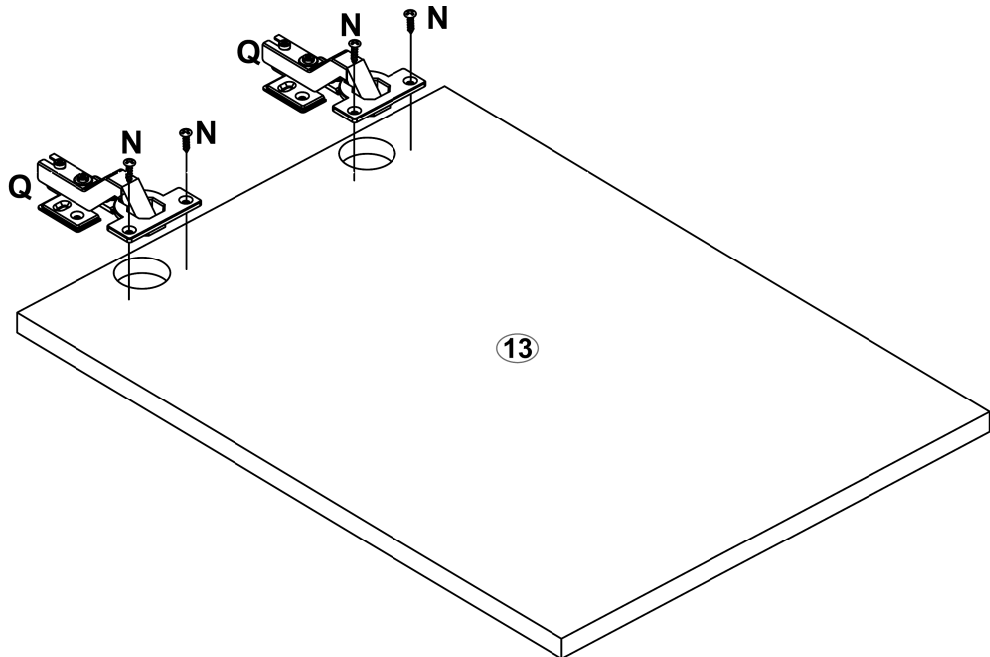

13 -

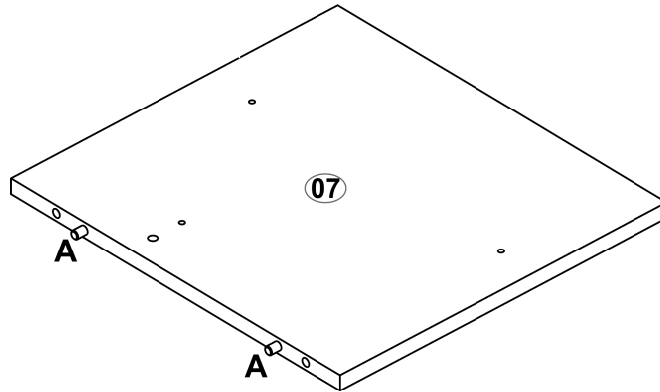
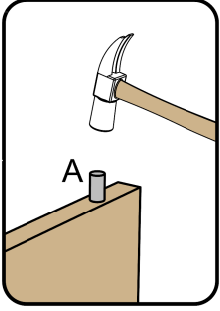

14 -

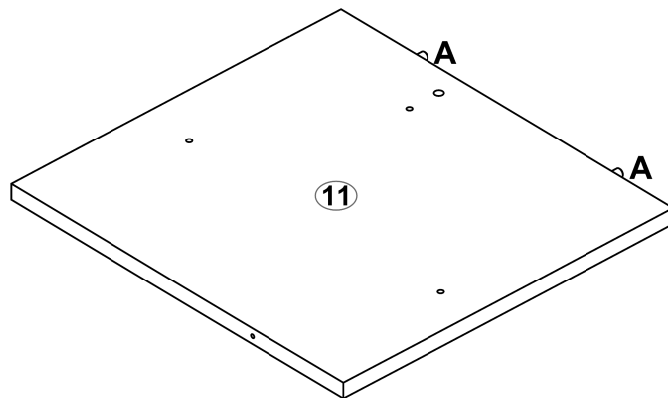
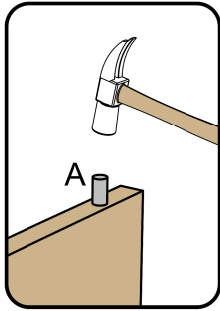

15 -

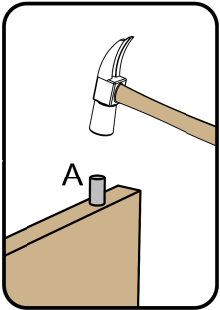

2x

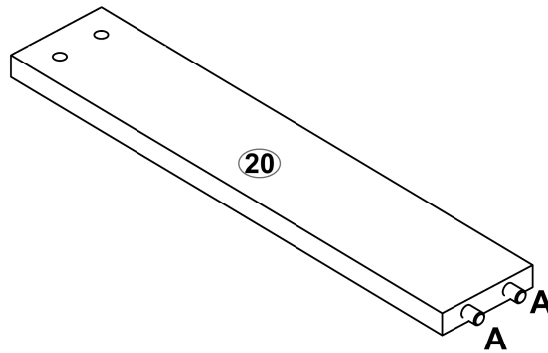

16 -

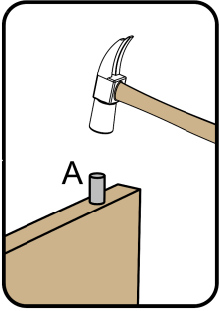

2x

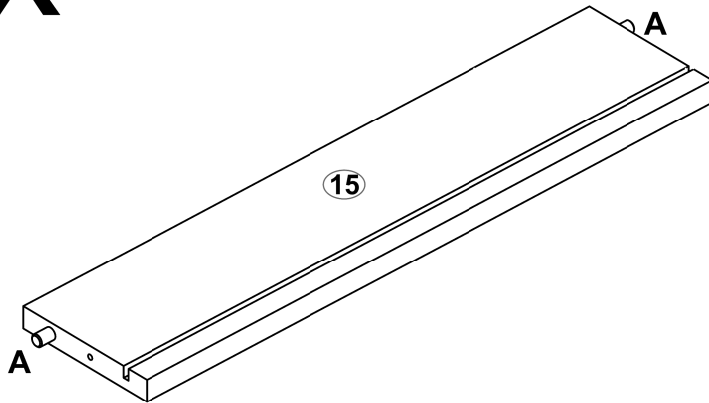

17 -

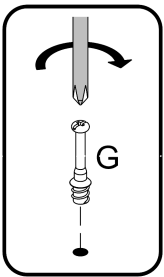

2x

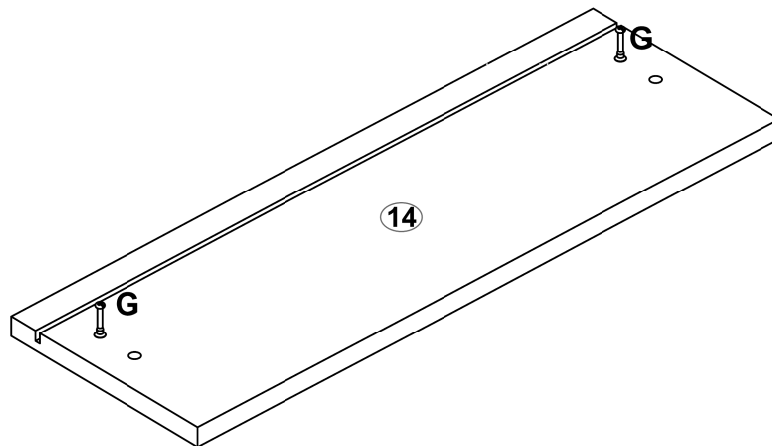

18 -

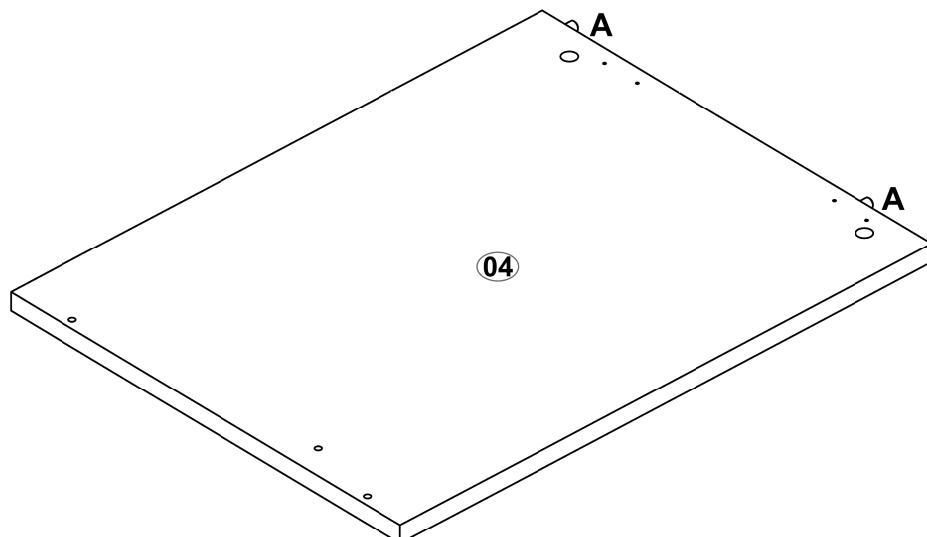
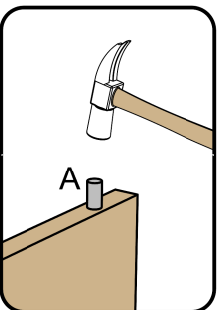

ASSEMBLY - MONTAGE - ARMADO - MONTAGEM

M01 -

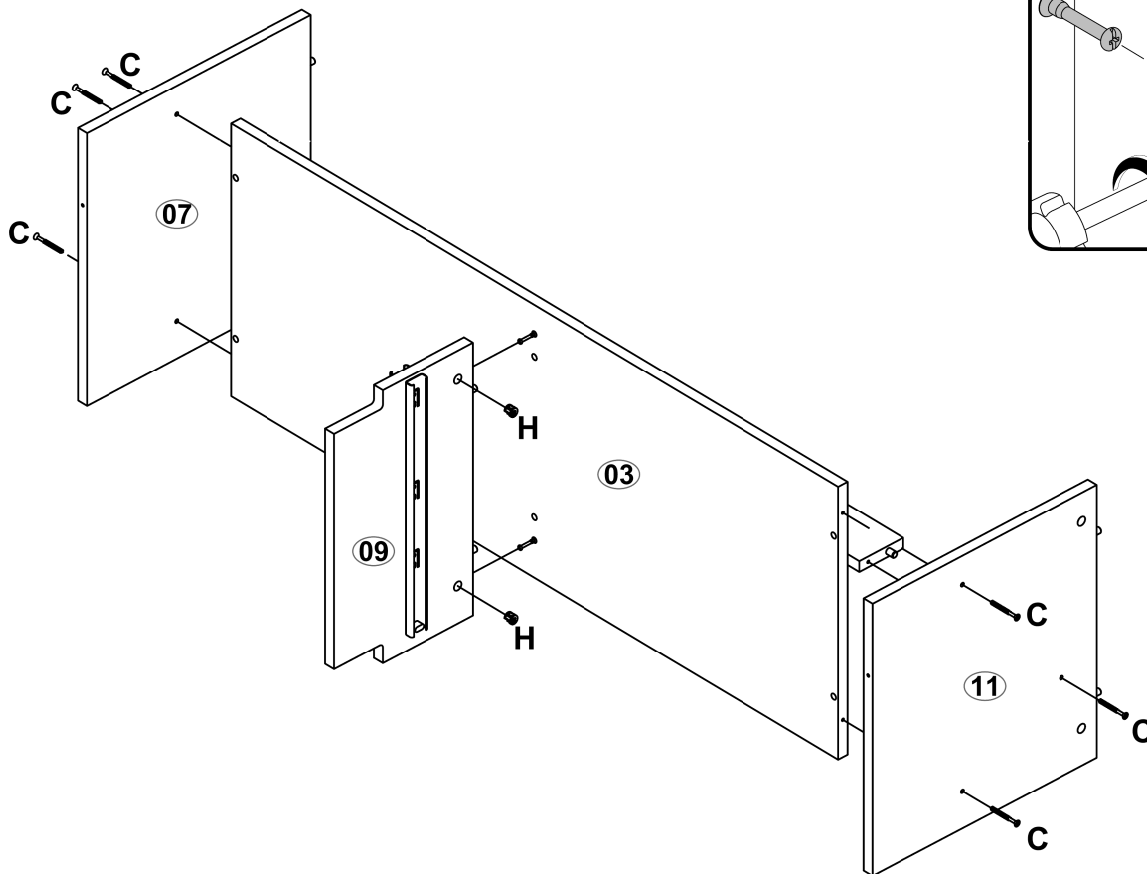

M02 -

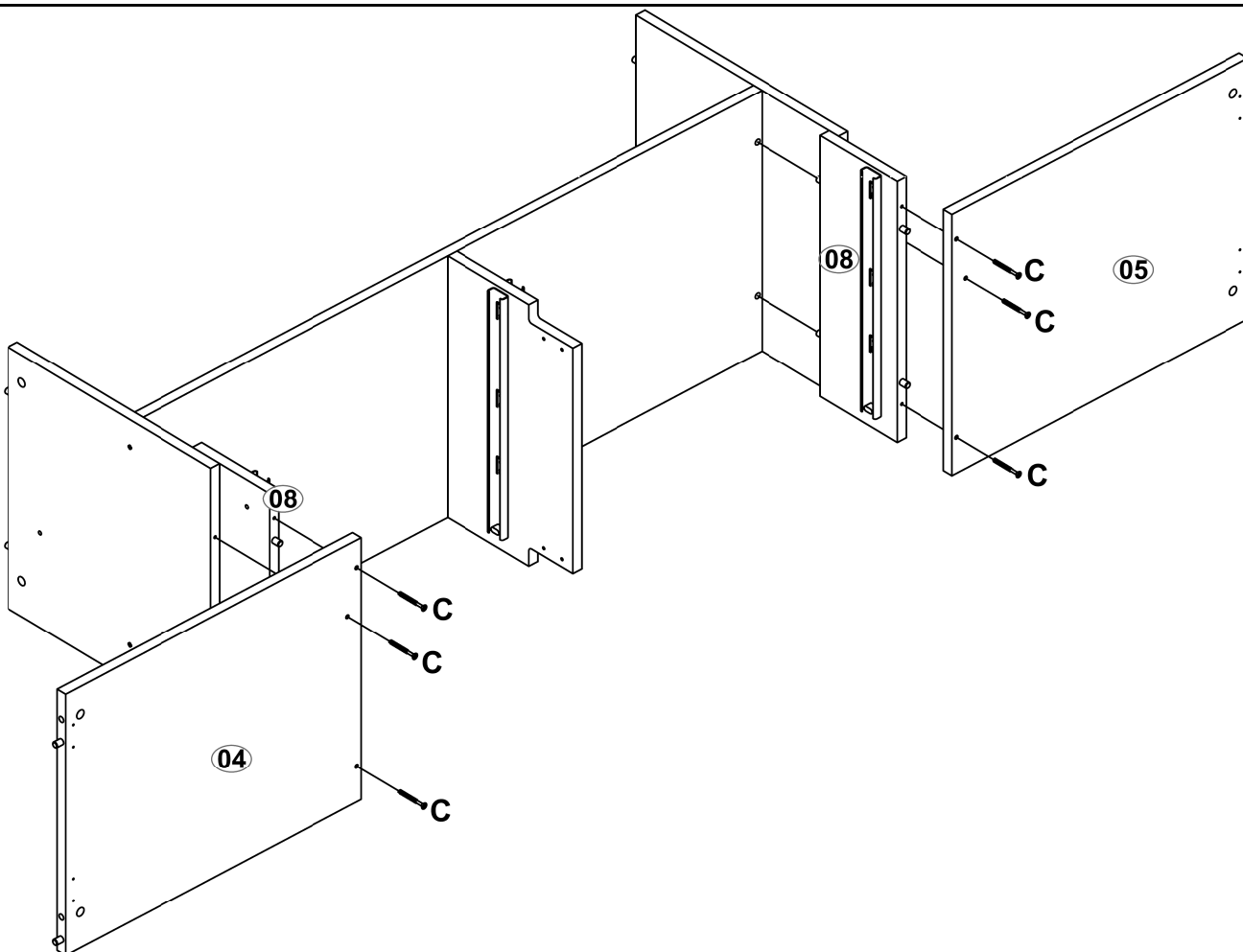

M03 -

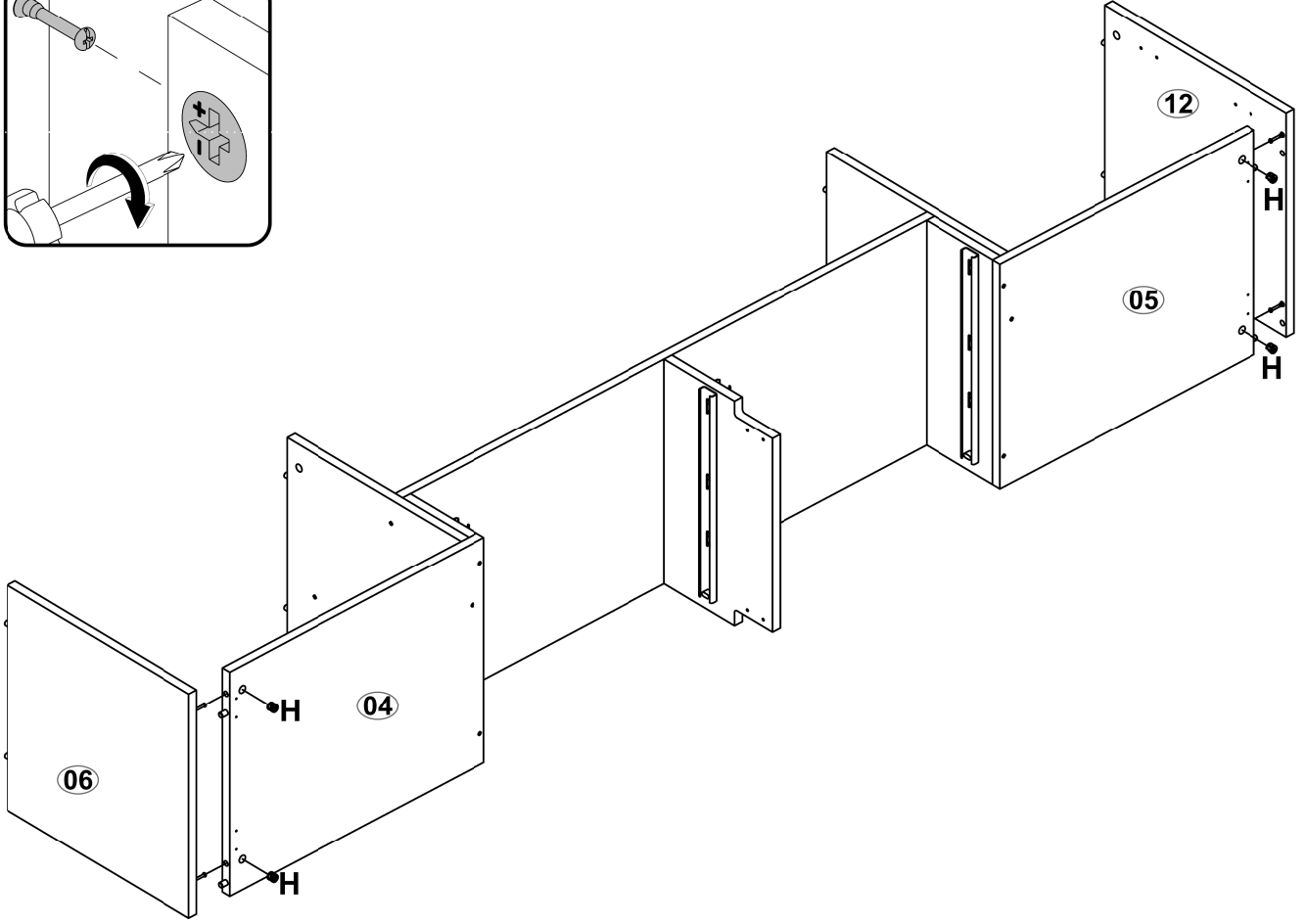
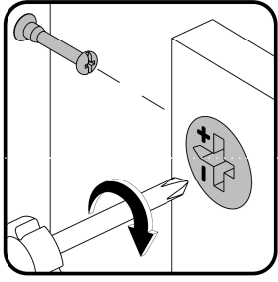

M04 -

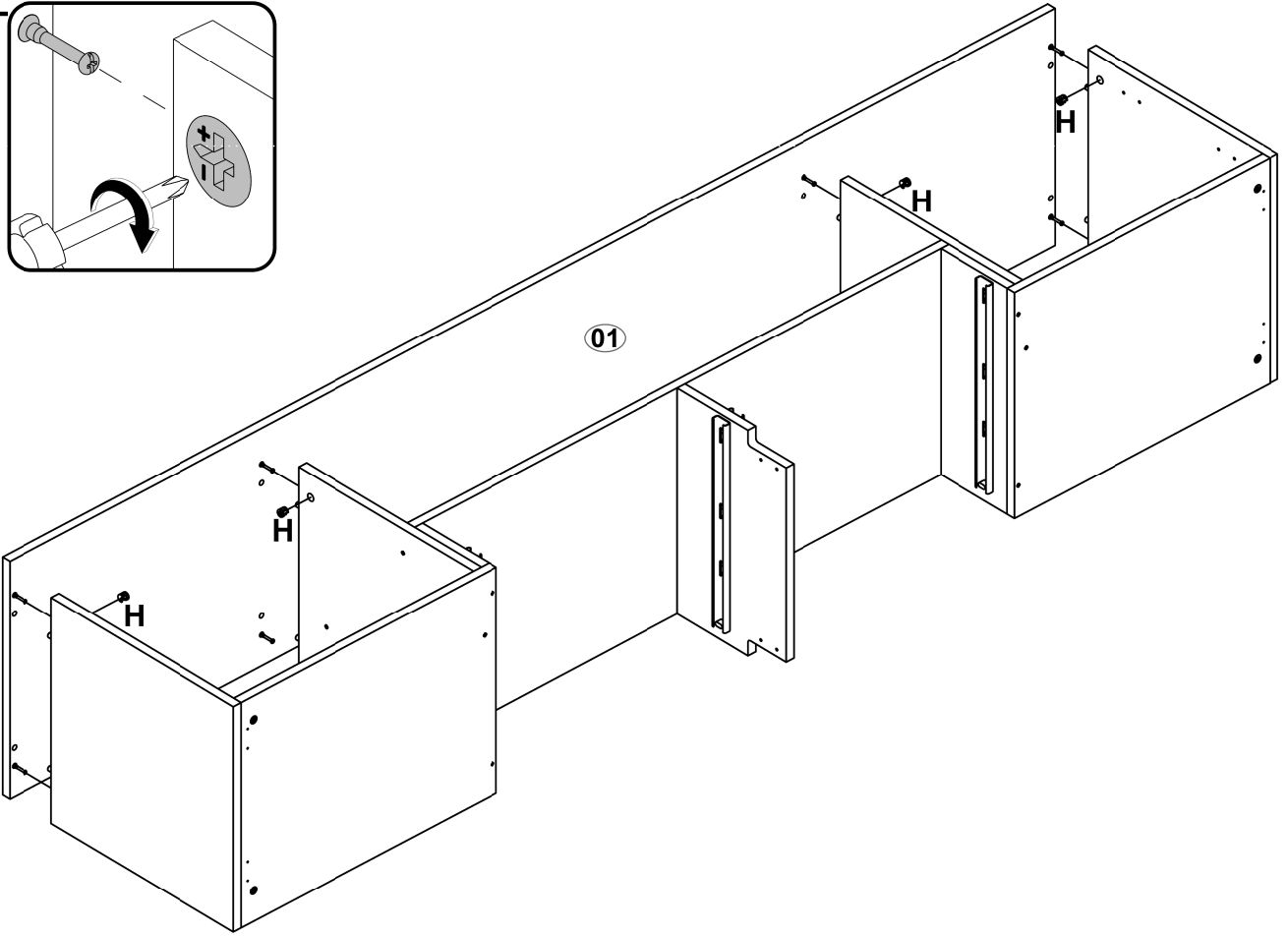
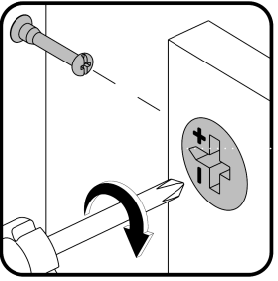

M05 -

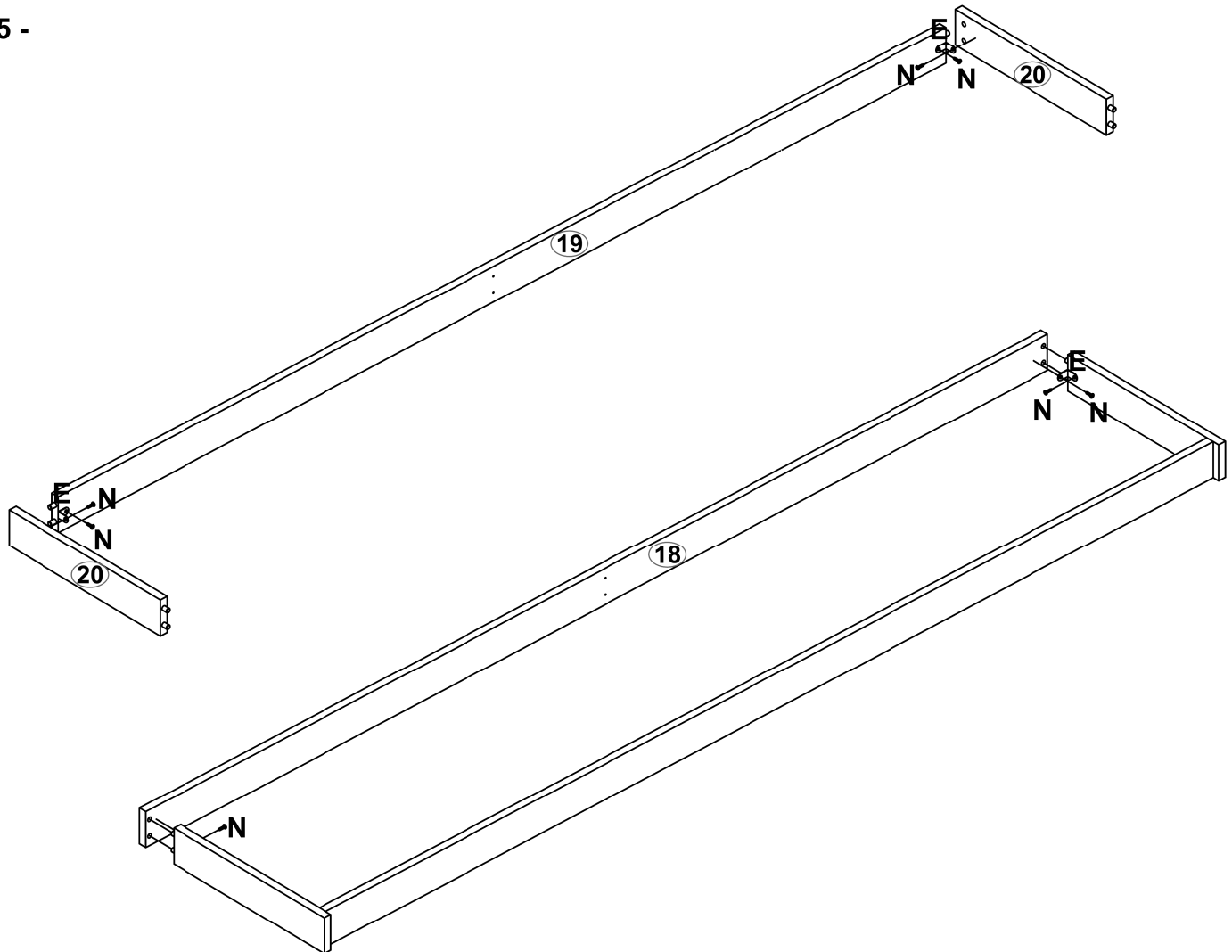

M06 -

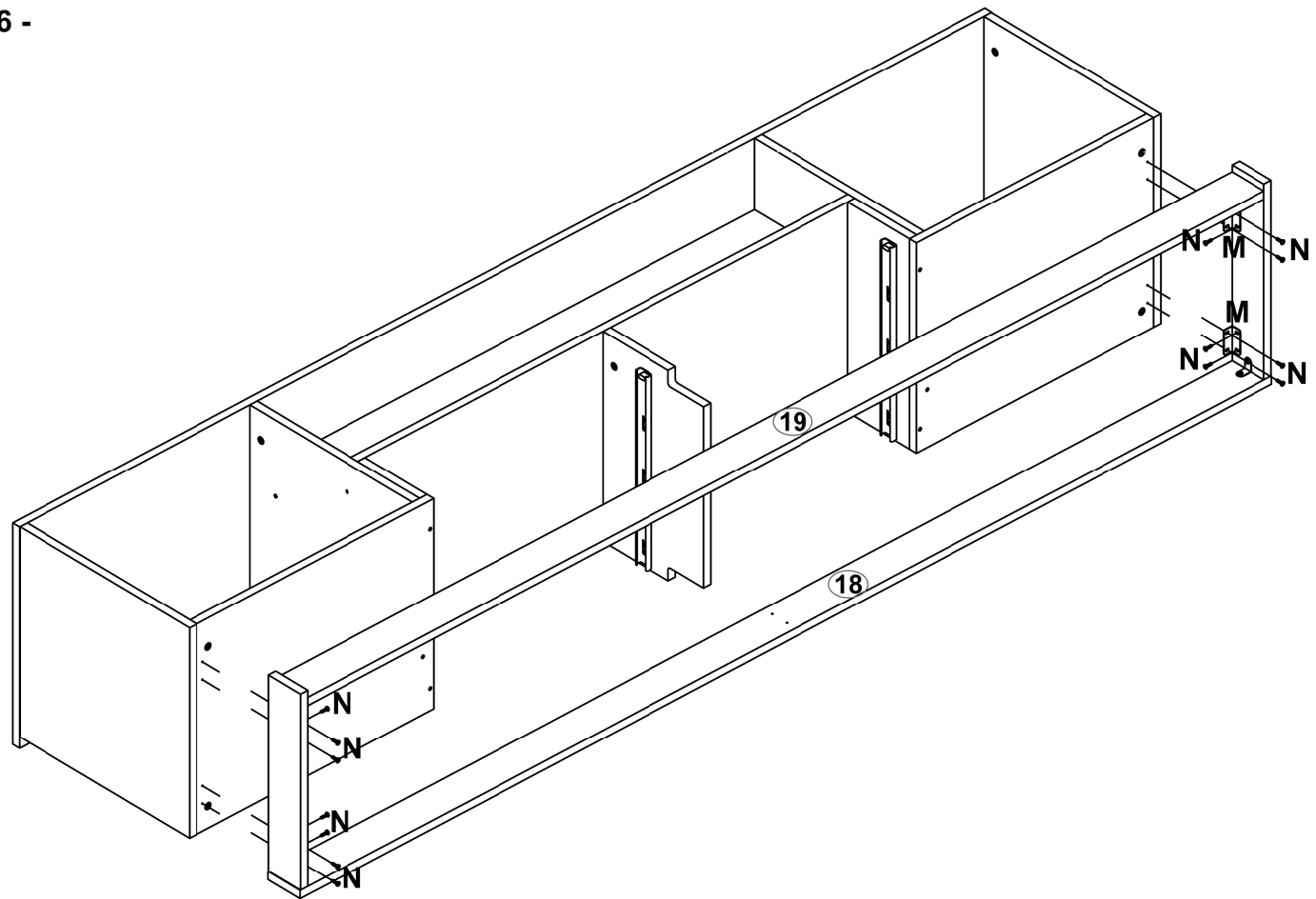

M07 -

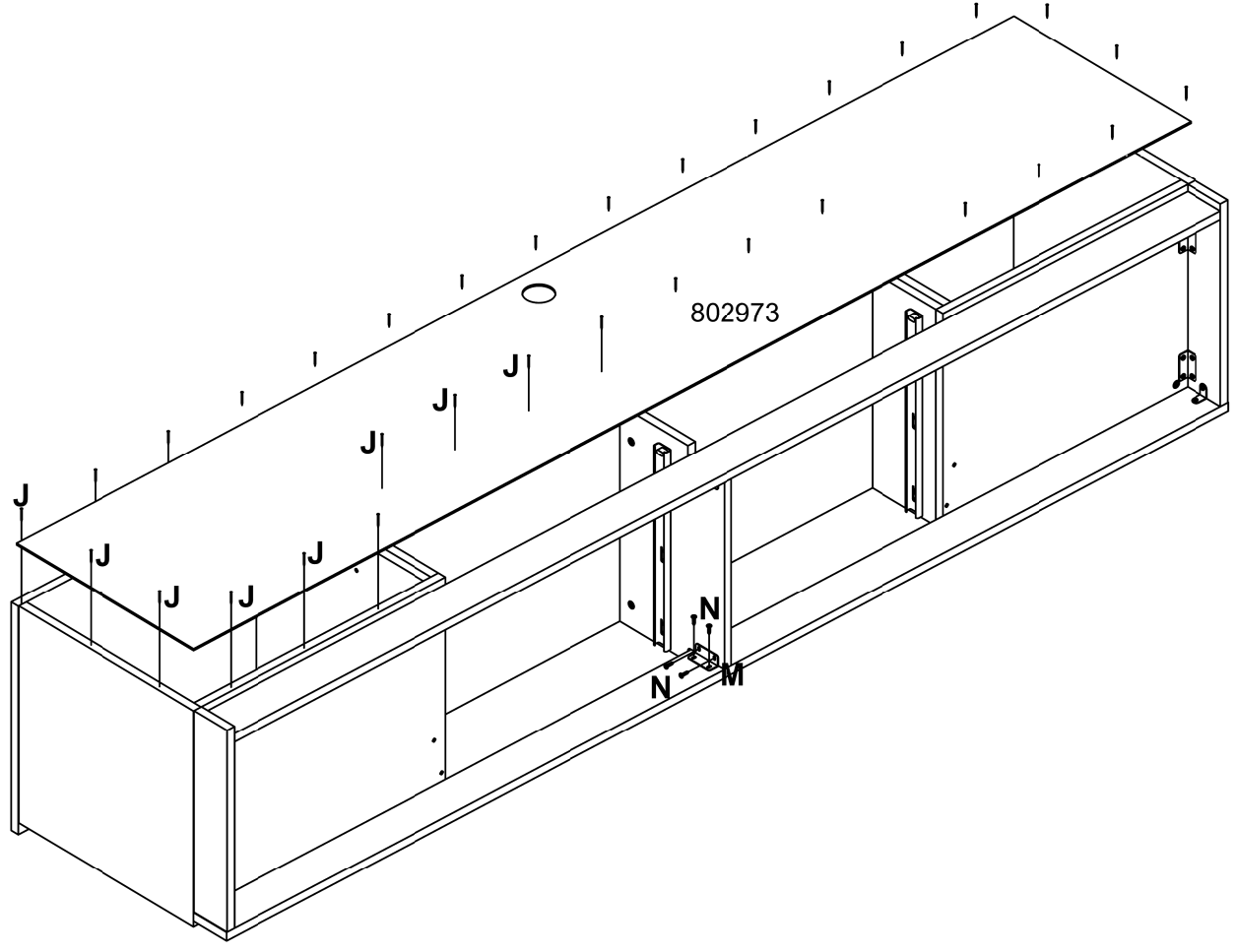

M08 -

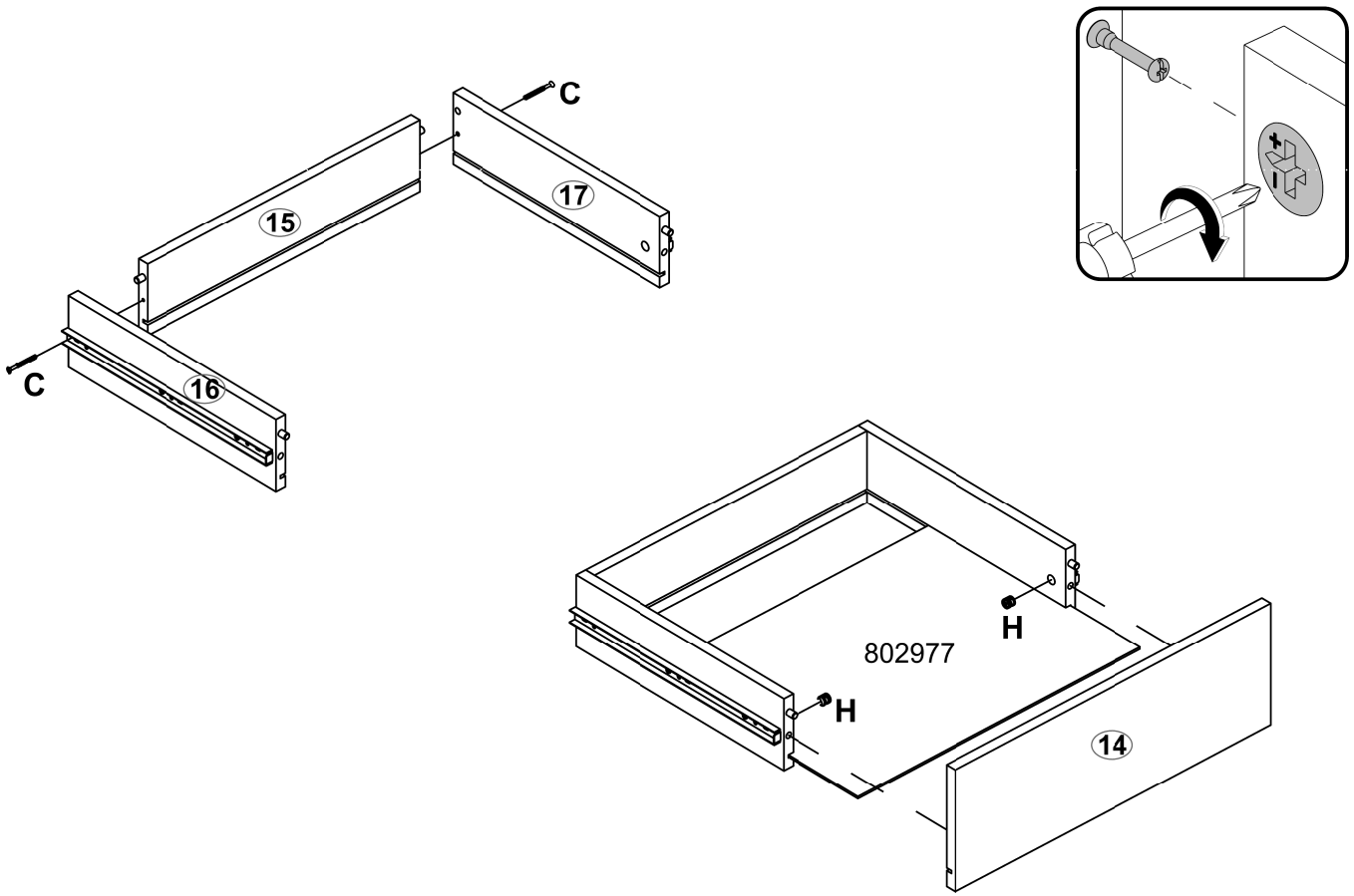

M09 -

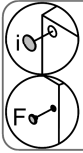

***Note:** Use the stickers and caps to finish.

***Remarque:** Utiliser les autocollants et les capuchons pour terminer la finition.

***Nota:** Utilice los adhesivos y tapas para finalizar el acabado.

***Nota:** Utilize os adesivos e tampas para finalizar o acabamento.

