

**Dicas de Conservação / Maintenance Tips / Consejos de Mantenimiento**

\*Para limpar ou tirar manchas, utilize uma flanela umedecida em solução de água e álcool, na mesma proporção. Evite exposição ao sol.

\*To clean or remove stains, use a piece of flannel dampened with a water and alcohol solution, in the same proportion. Avoid direct sunlight.

\*Para limpiar o sacar manchas, utilice una flanela humedecida en solución de agua y alcohol, en la misma proporción. Evite la exposición directa al sol.

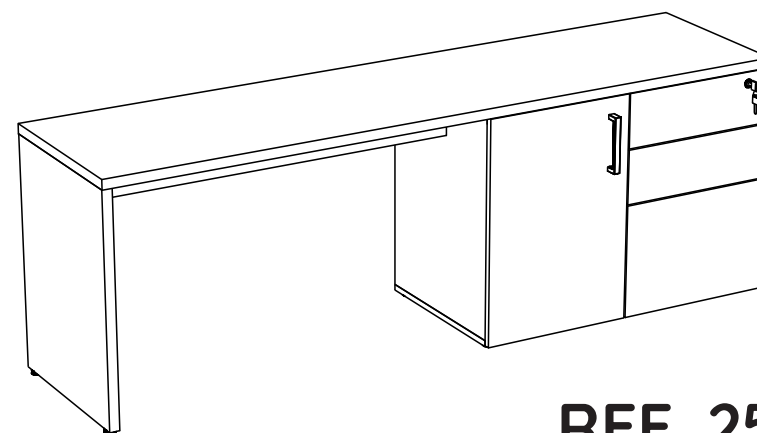
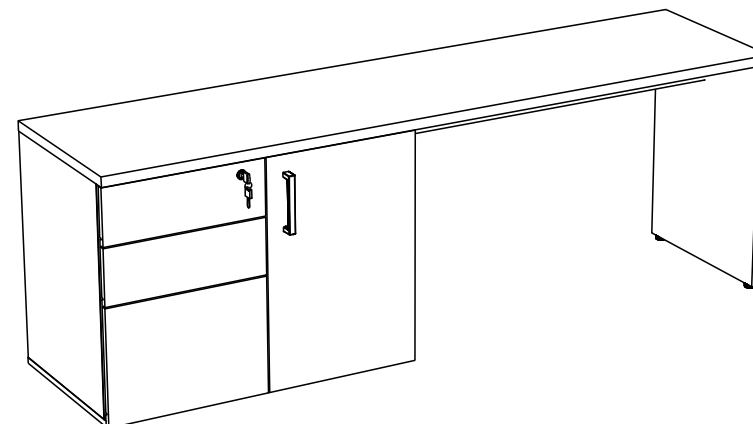

**REF. 25860**



# FERRAGENS / HARDWARE LIST / LISTA DE HERRAJES

Os desenhos das ferragens são em escala real, então suas dimensões são iguais às das ferragens reais.

The hardware drawings are full-scale, so their dimensions are the same as the actual hardware.

Los dibujos de los herrajes son la escala real, por lo que sus dimensiones son las mismas que las del herraje real.

ID	IMAGEM DE REFERÊNCIA / IMAGE REFERENCE IMAGEN REFERENCIA	QUANTIDADE # OF PIECES CANTIDAD
A	4,5x45mm	01
B	4,5x35mm	12
C	3,5x35mm	02
D	3,5x14mm	12
E	3,5x12mm	24
F		16
G		18
H1		17
H2		01
I	8x30mm	28
J	400mm	02
K	400mm	02
L		07
M		01
N		02
O		01
P	400mm	01
Q		02
R	5x8	04
S		02
T		01

## 18 Passo Step Paso

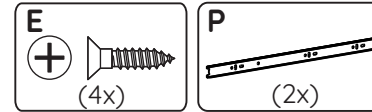
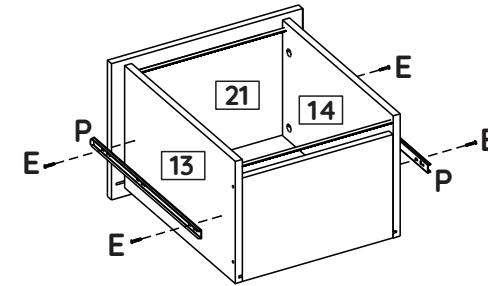

## 19 Passo Step Paso

OPCIONAL NA DIREITA  
OPTIONAL RIGHT  
OPCIONAL DERECHA

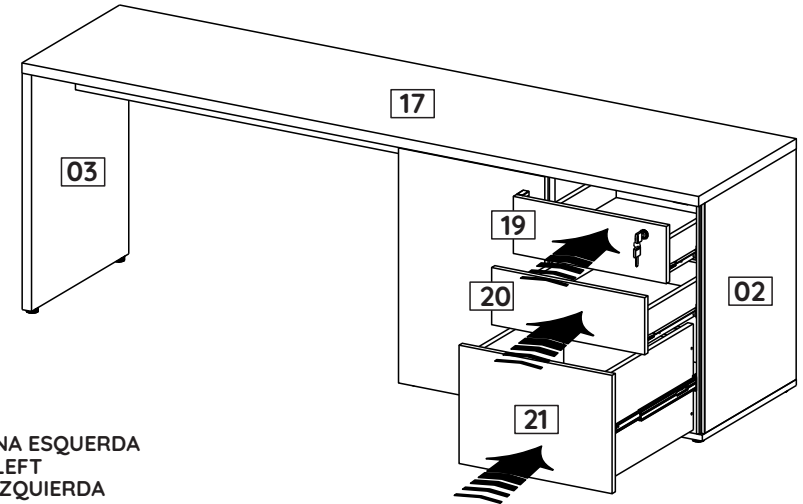

OPCIONAL NA ESQUERDA  
OPTIONAL LEFT  
OPCIONAL IZQUIERDA

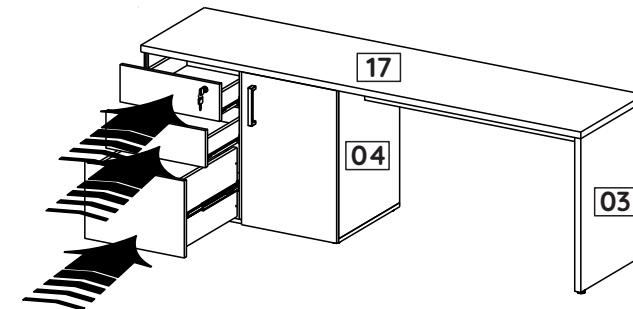

**15** Passo  
Step  
Paso

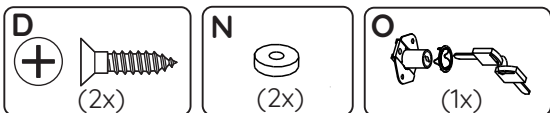
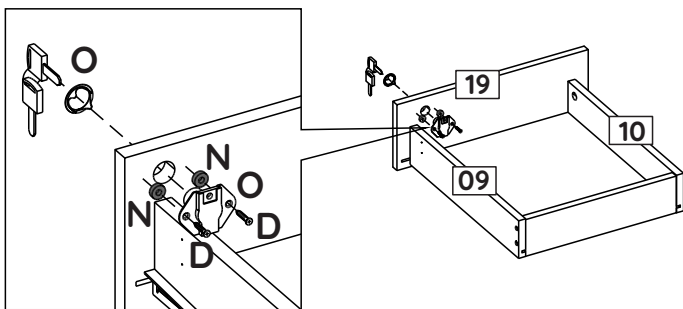

**16** Passo  
Step  
Paso

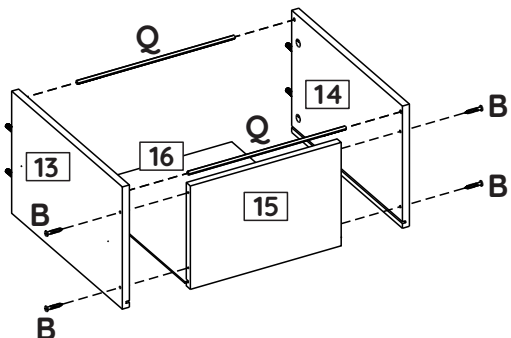
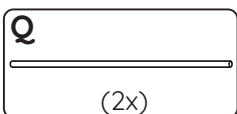
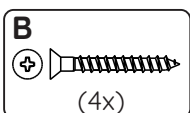

**17** Passo  
Step  
Paso

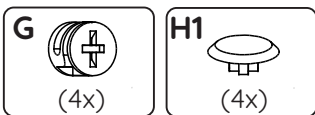
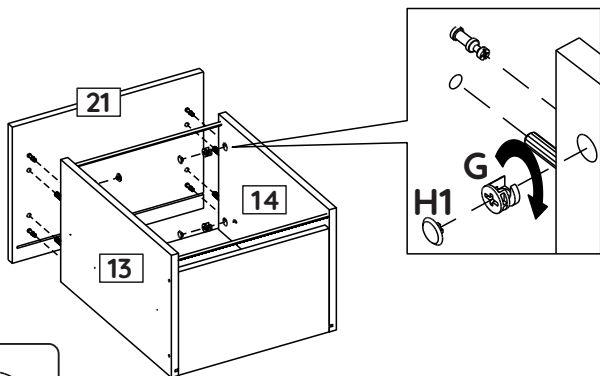

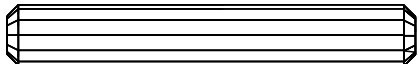
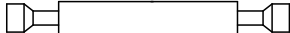
ID	IMAGEM DE REFERÊNCIA / IMAGE REFERENCE IMAGEN REFERENCIA	QUANTIDADE # OF PIECES CANTIDAD
U	 8x50mm	02
V		01

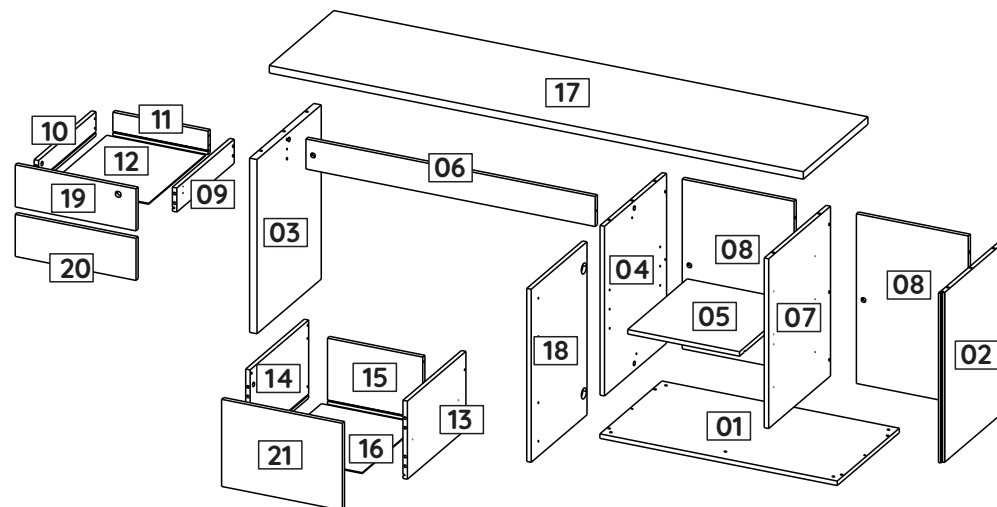

ID	Descrição / Description / Denominación	Quantidade # Of Pieces Cantidad	Dimensão (mm) Dimension (mm) Dimensión (mm)
01	Base/Base/Base	01	800x433x15
02	Lateral direita/Right side/Lateral derecha	01	565x423x15
03	Lateral esquerda/Left side/Lateral izquierda	01	565x433x25
04	Lateral apoio/Side support/Lateral soporte	01	580x448x15
05	Prateleira/Shelf/Repisa	01	377x415x15
06	Travessa/Traverse/Travesaño	01	975x100x15
07	Divisão/Division/División	01	565x415x15
08	Costa/Back/Revés	02	565x377x15
09	Lateral gaveta direita/Right drawer side/Lateral cajón derecha	02	400x80x15
10	Lateral gaveta esquerda/Left drawer side/Lateral cajón izquierda	02	400x80x15
11	Costa gaveta/Drawer back/Revés cajón	02	321x78x15
12	Fundo gaveta/Drawer bottom/Fondo cajón	02	398x333x3
13	Lateral gav. dir. maior/Larger right drawer side/Lateral cajón derecha mayor	01	408x260x15
14	Lateral gav. esq. maior/Larger left drawer side/Lateral cajón izquierda mayor	01	408x260x15
15	Costa gaveta maior/Larger drawer back/Revés cajón mayor	01	321x220x715
16	Fundo gaveta maior/Larger drawer bottom/Fondo cajón mayor	01	404x333x3
17	Tampo/Top/Tapa	01	1800x450x15
18	Porta/Door/Puerta	01	576x389x15
19	Frente gaveta chave/Front drawer key/Frente cajón LLave	01	140x407x15
20	Frente gaveta/Drawer front/Frente cajón	01	140x407x15
21	Frente gaveta maior/Larger drawer front/Frente cajón mayor	01	290x407x15

**1** Passo  
Step  
Paso

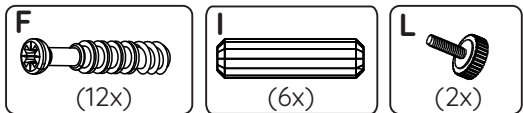
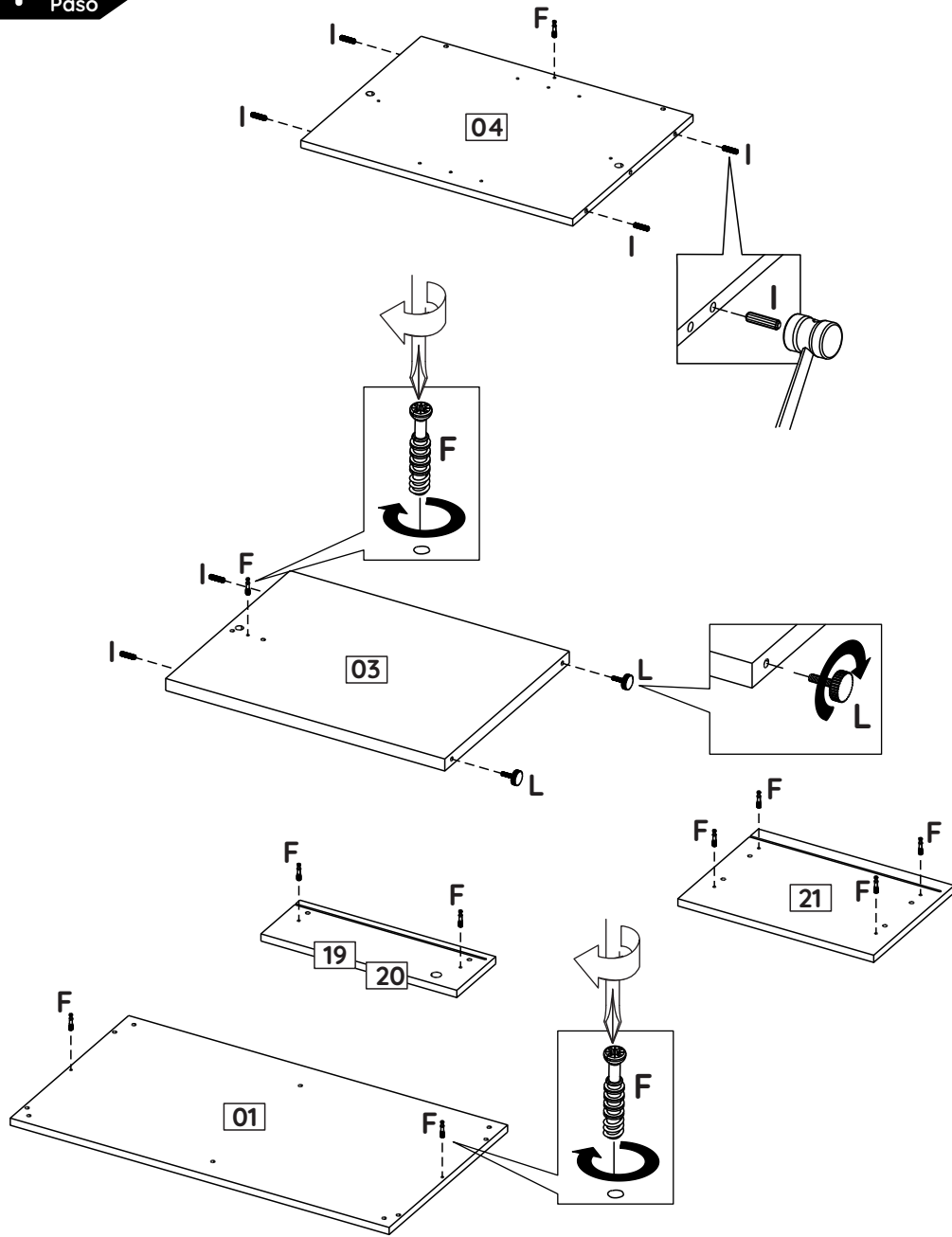

**12** Passo  
Step  
Paso

(2x)

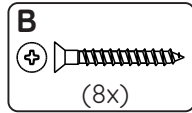
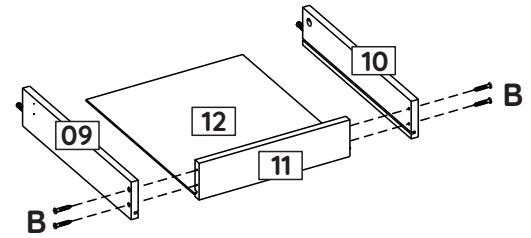

**13** Passo  
Step  
Paso

(2x)

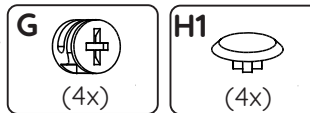
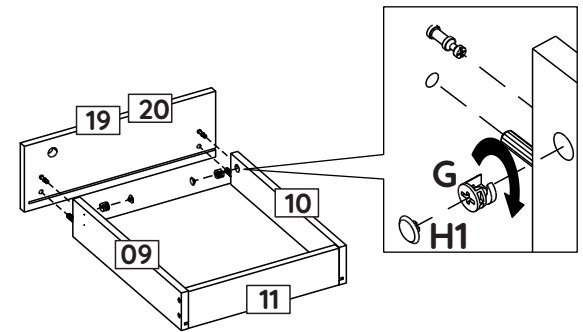

**14** Passo  
Step  
Paso

(2x)

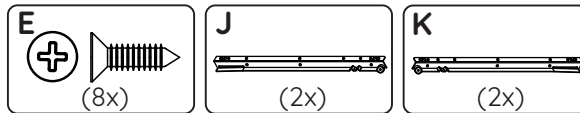
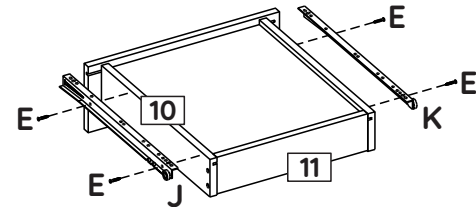

**11** Passo  
Step  
Paso

OPCIONAL NA DIREITA  
OPTIONAL RIGHT  
OPCIONAL DERECHA

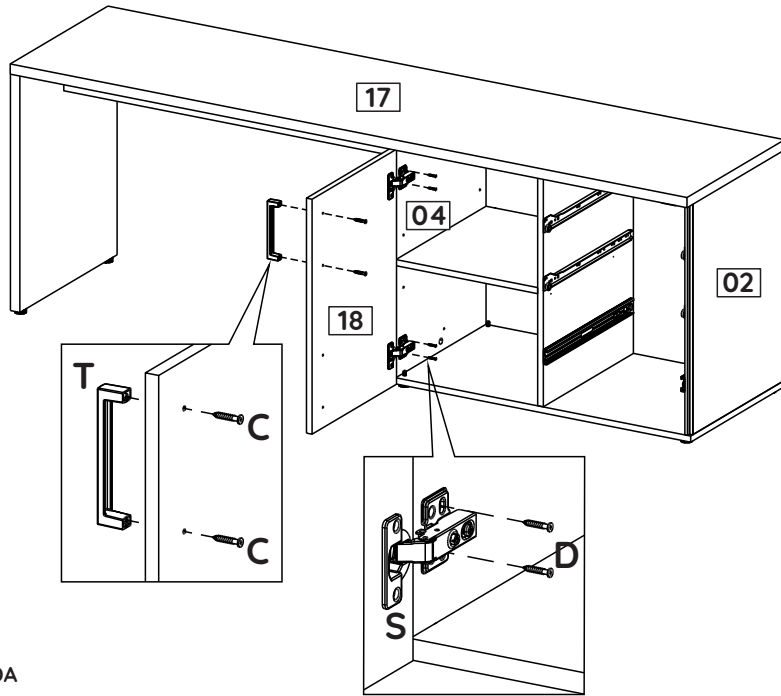

OPCIONAL NA ESQUERDA  
OPTIONAL LEFT  
OPCIONAL IZQUIERDA

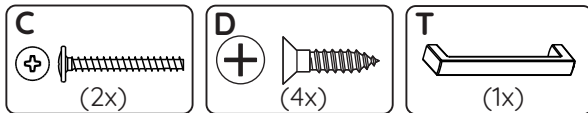
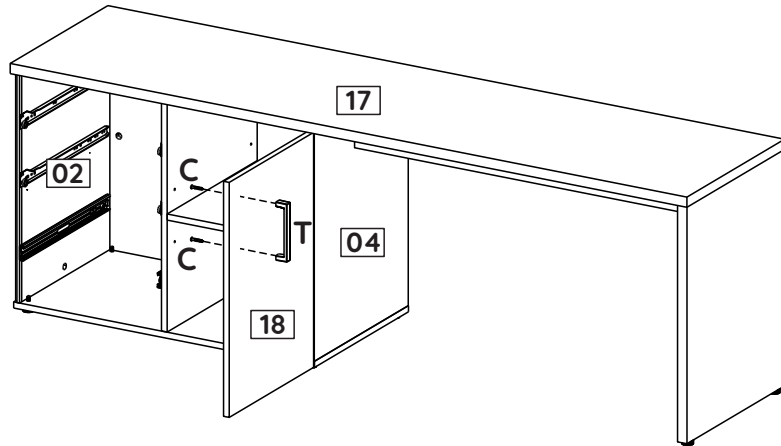

**2** Passo  
Step  
Paso

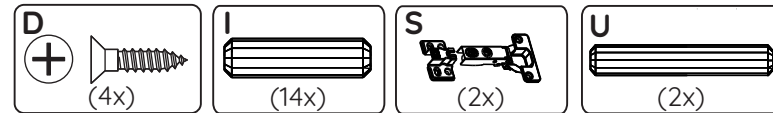
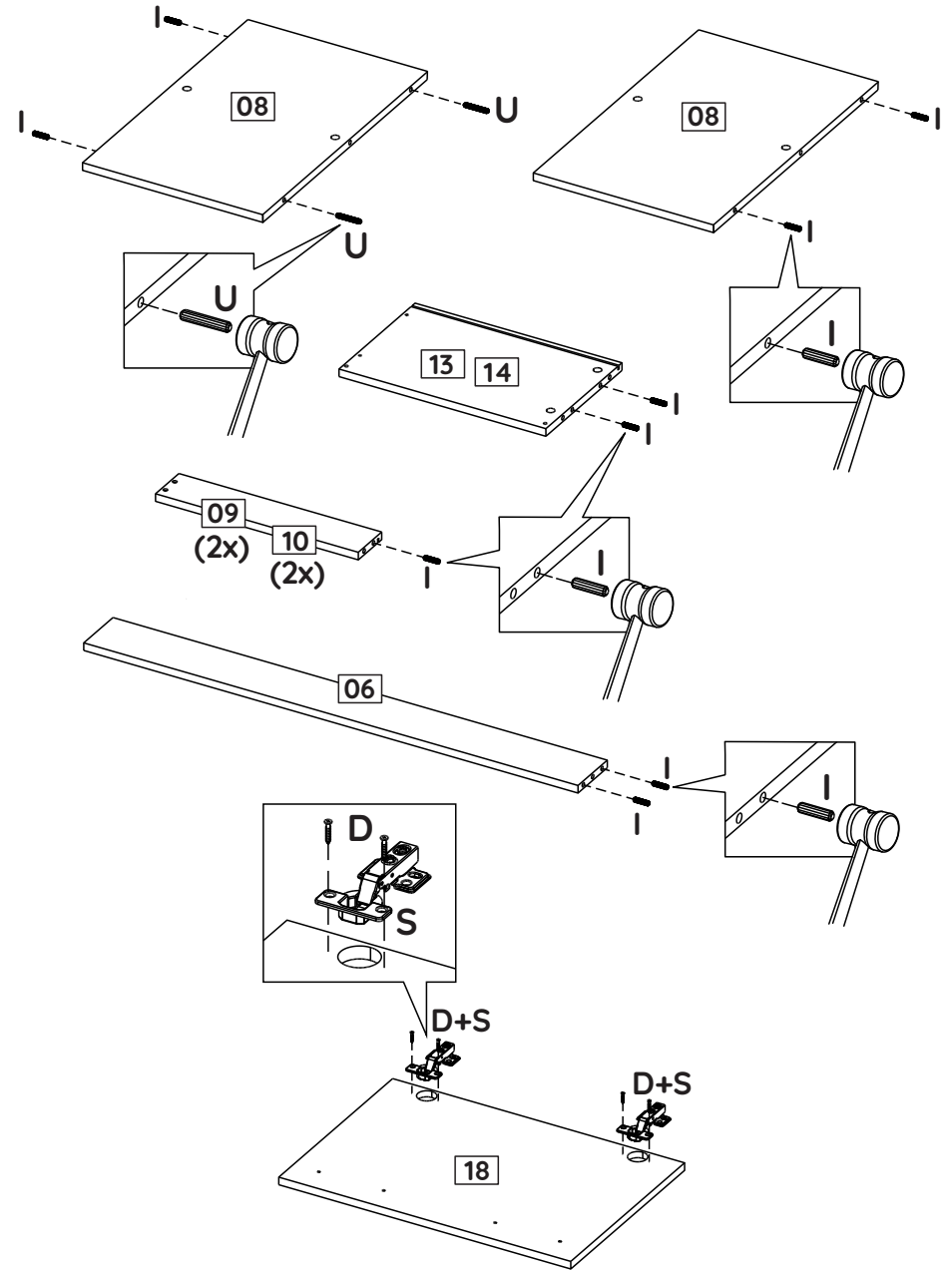

3  
Passo  
Step  
Paso

OPCIONAL NA DIREITA  
OPTIONAL RIGHT  
OPCIONAL DERECHA

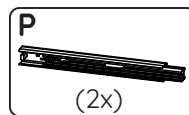
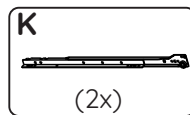
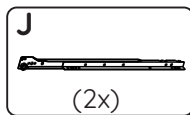
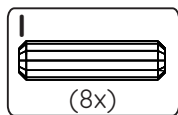
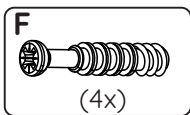
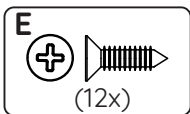
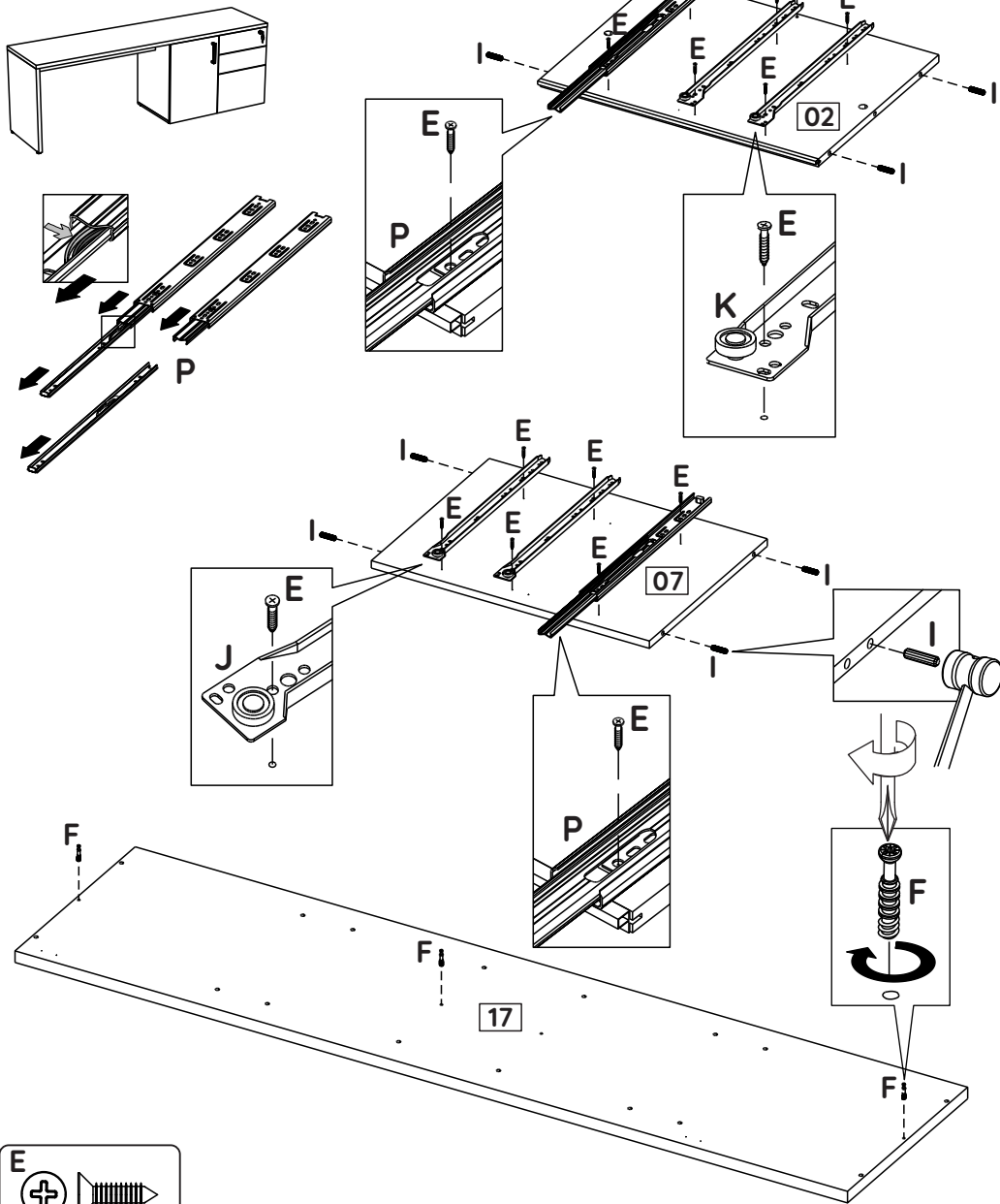

10  
Passo  
Step  
Paso

OPCIONAL NA DIREITA  
OPTIONAL RIGHT  
OPCIONAL DERECHA

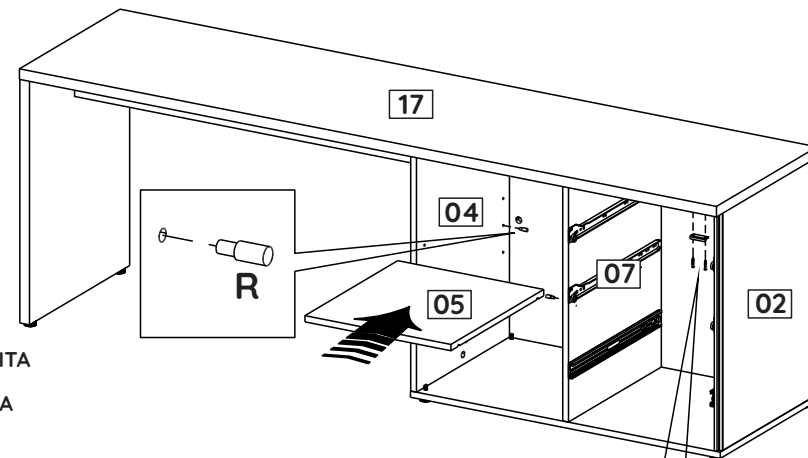

OPCIONAL NA ESQUERDA  
OPTIONAL LEFT  
OPCIONAL IZQUIERDA

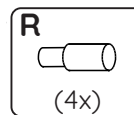
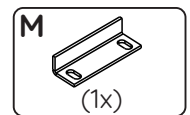
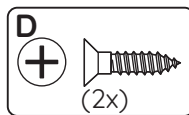
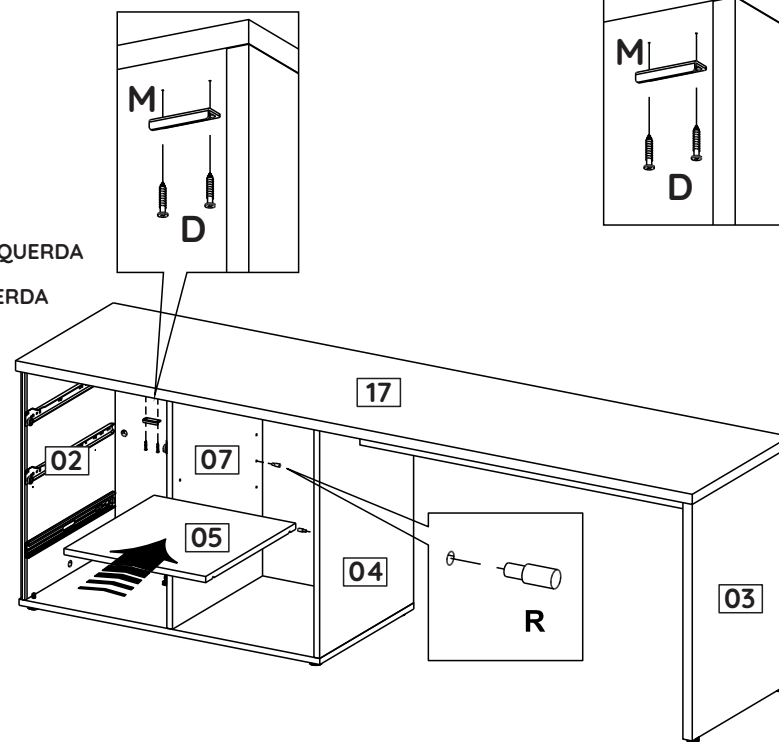

**9** Passo  
Step  
Paso

OPCIONAL NA DIREITA  
OPTIONAL RIGHT  
OPCIONAL DERECHA

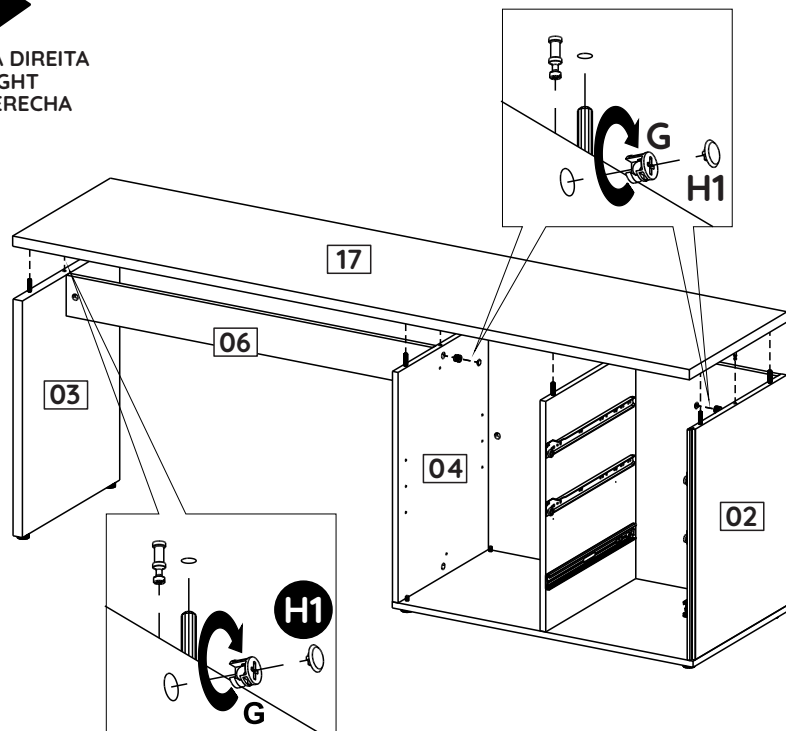

OPCIONAL NA ESQUERDA  
OPTIONAL LEFT  
OPCIONAL IZQUIERDA

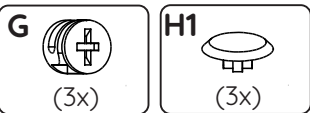
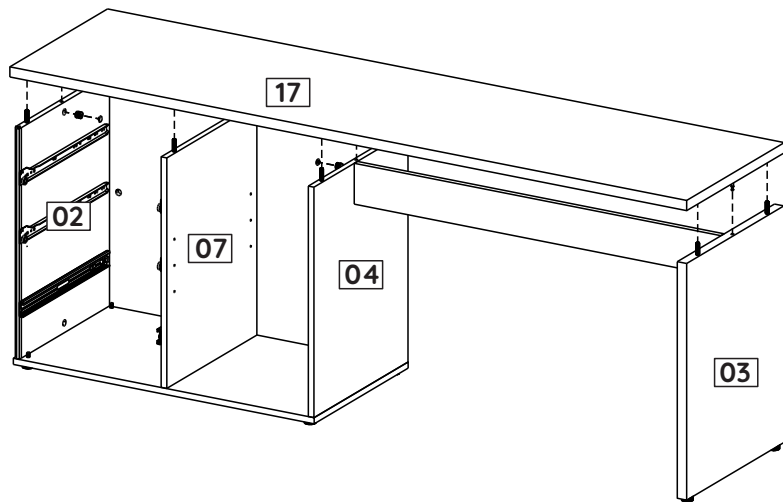

**4** Passo  
Step  
Paso

OPCIONAL NA ESQUERDA  
OPTIONAL LEFT  
OPCIONAL IZQUIERDA

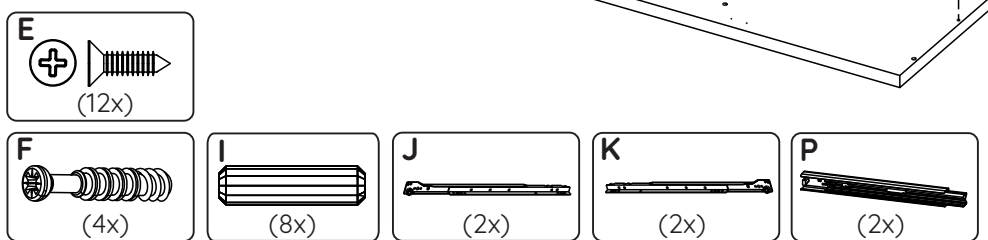
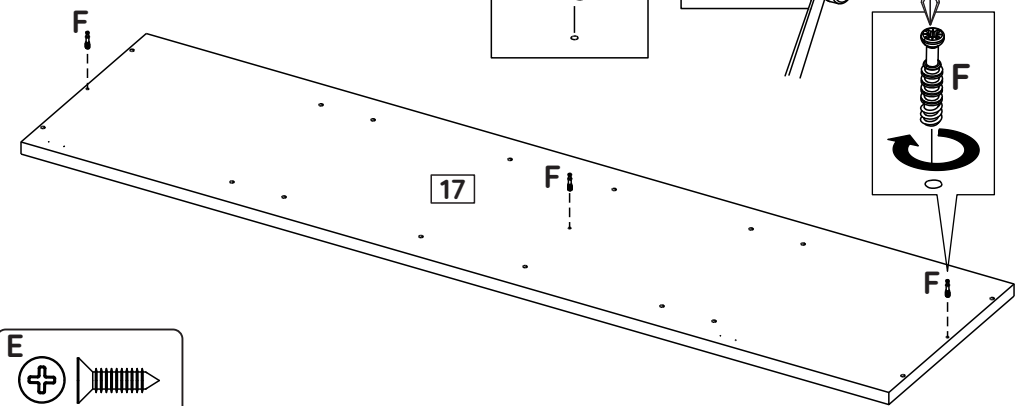
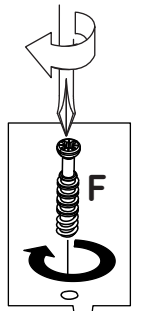
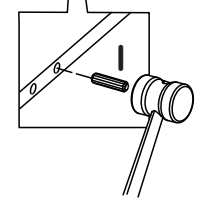
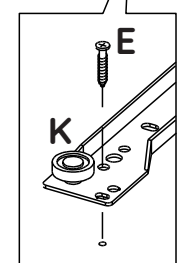
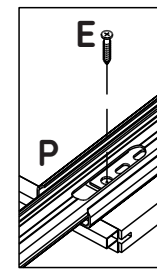
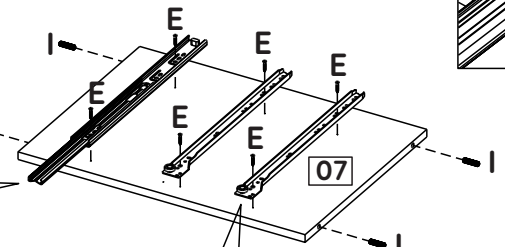
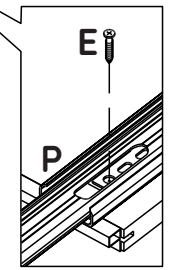
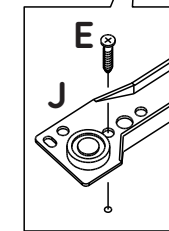
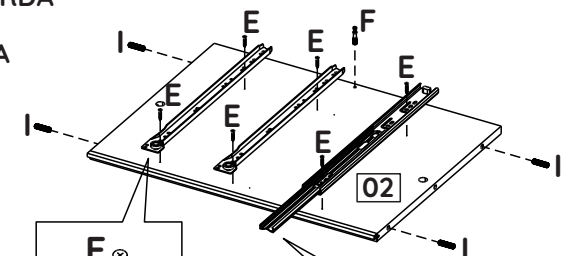
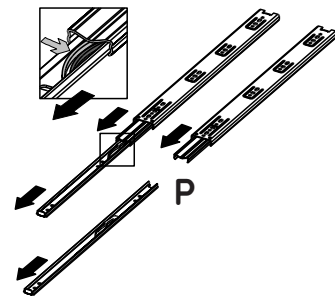
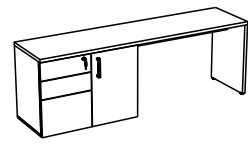

**5** Passo  
Step  
Paso

OPCIONAL NA DIREITA  
OPTIONAL RIGHT  
OPCIONAL DERECHA

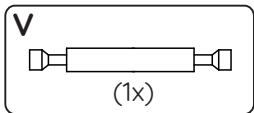
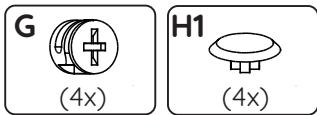
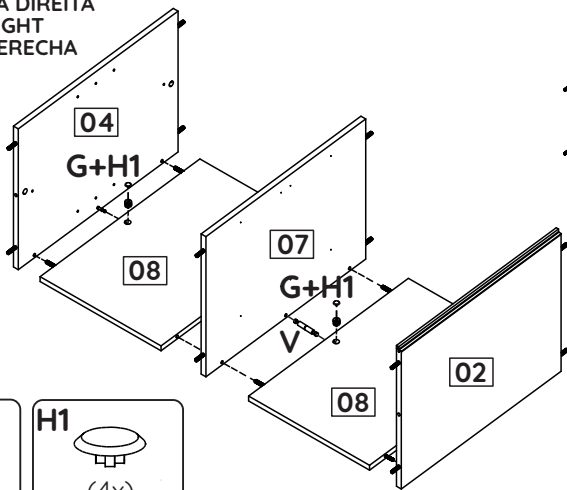

OPCIONAL NA ESQUERDA  
OPTIONAL LEFT  
OPCIONAL IZQUIERDA

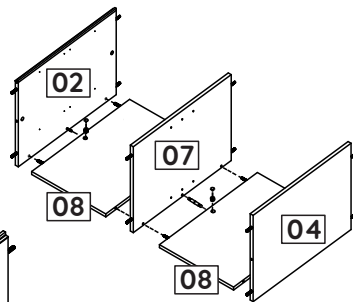

**7** Passo  
Step  
Paso

OPCIONAL NA ESQUERDA  
OPTIONAL LEFT  
OPCIONAL IZQUIERDA

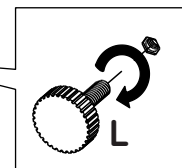
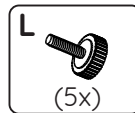
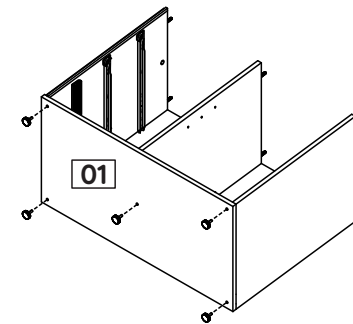
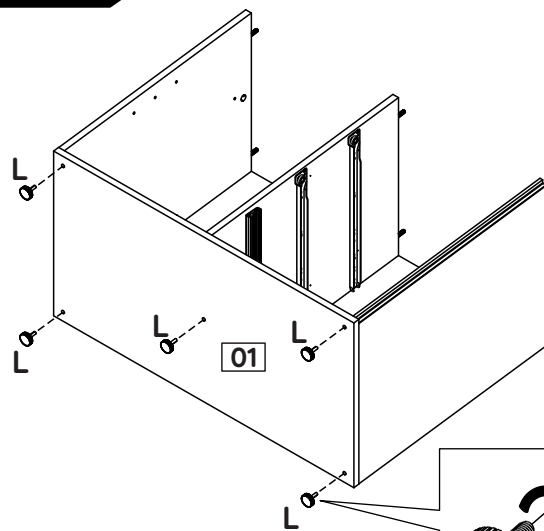

**6** Passo  
Step  
Paso

OPCIONAL NA DIREITA  
OPTIONAL RIGHT  
OPCIONAL DERECHA

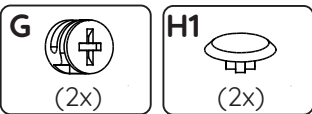
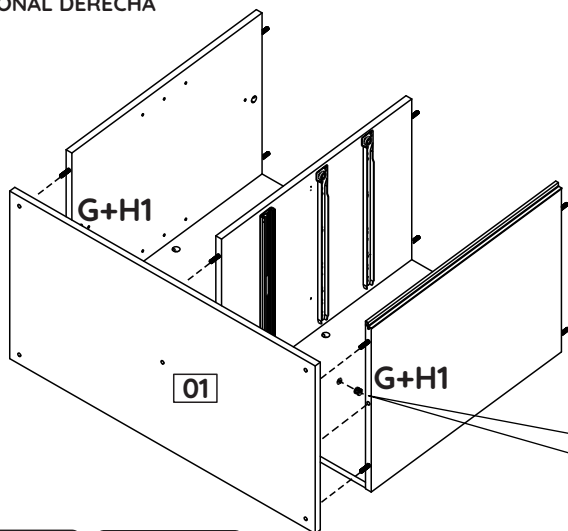

OPCIONAL NA ESQUERDA  
OPTIONAL LEFT  
OPCIONAL IZQUIERDA

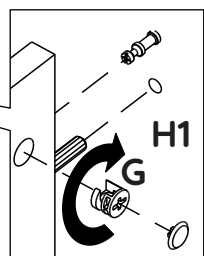
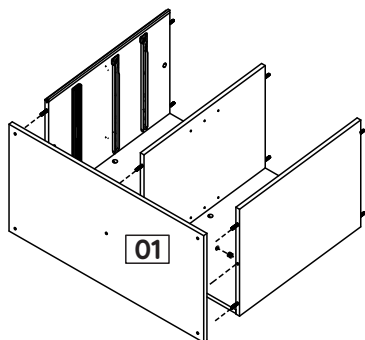

**8** Passo  
Step  
Paso

OPCIONAL NA DIREITA  
OPTIONAL RIGHT  
OPCIONAL DERECHA

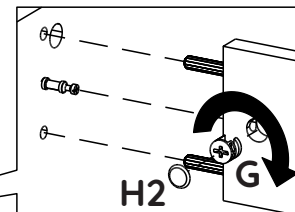
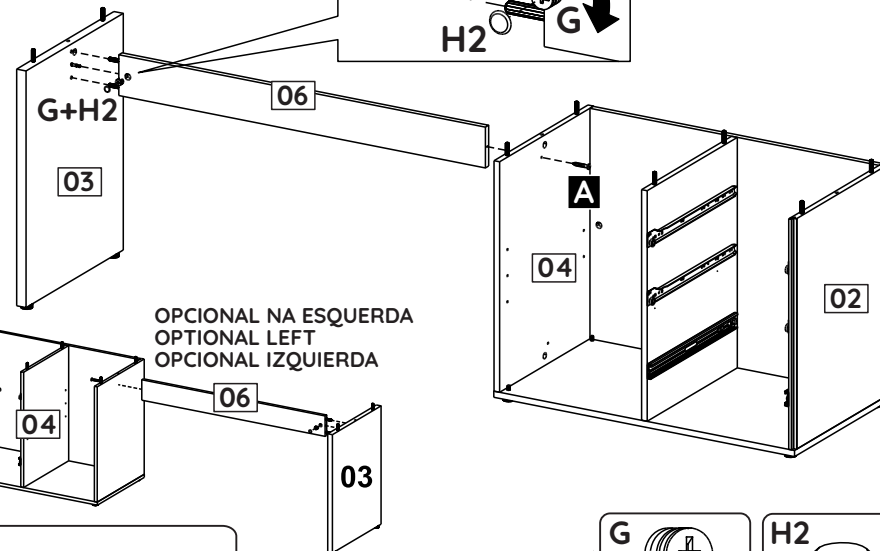

OPCIONAL NA ESQUERDA  
OPTIONAL LEFT  
OPCIONAL IZQUIERDA

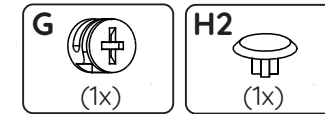
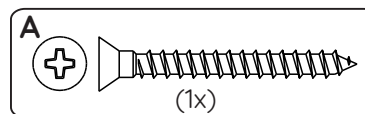
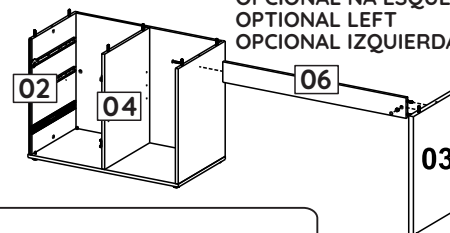

**4** Passo  
Step  
Paso

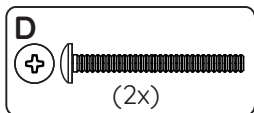
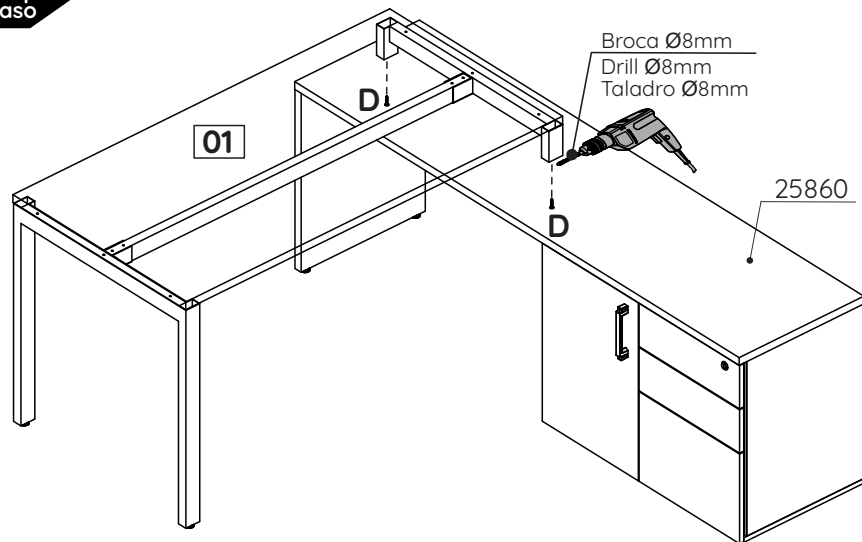

**5** Passo  
Step  
Paso

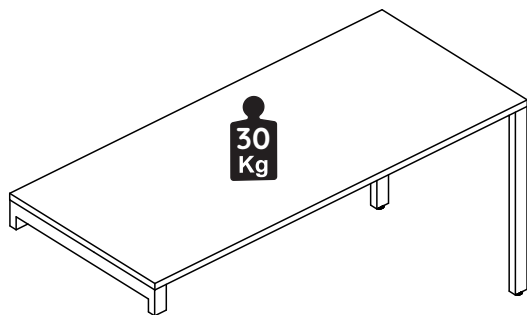

#### Dicas de Conservação / Maintenance Tips / Consejos de Mantenimiento

\*Para limpar ou tirar manchas, utilize uma flanela umedecida em solução de água e álcool, na mesma proporção. Evite exposição ao sol.

\*To clean or remove stains, use a piece of flannel dampened with a water and alcohol solution, in the same proportion. Avoid direct sunlight.

\*Para limpiar o sacar manchas, utilice una flanela humedecida en solución de agua y alcohol, en la misma proporción. Evite la exposición directa al sol.

## INSTRUÇÕES DE MONTAGEM ASSEMBLY INSTRUCTIONS INSTRUCCIONES DE MONTAJE

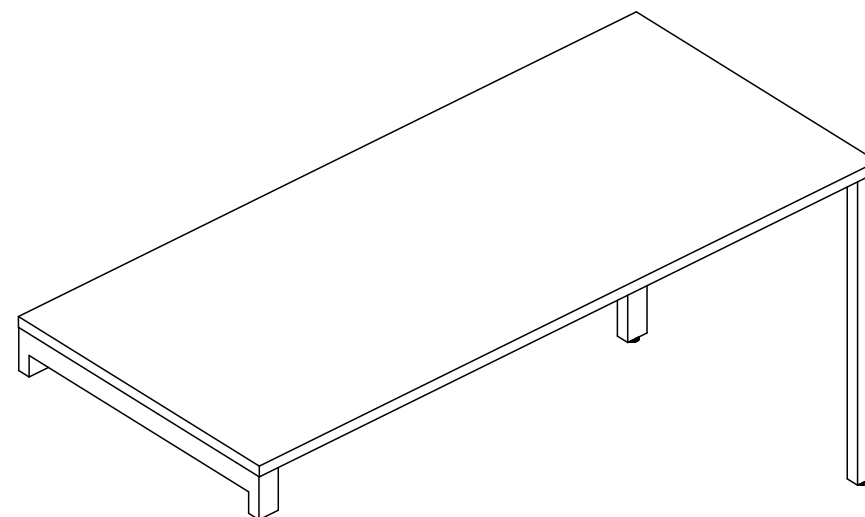



REF. 25859

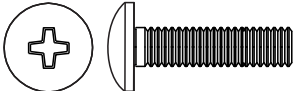

# FERRAGENS / HARDWARE LIST / LISTA DE HERRAJES

Os desenhos das ferragens são em escala real, então suas dimensões são iguais às das ferragens reais.  
The hardware drawings are full-scale, so their dimensions are the same as the actual hardware.  
Los dibujos de los herrajes son la escala real, por lo que sus dimensiones son las mismas que las del herraje real.

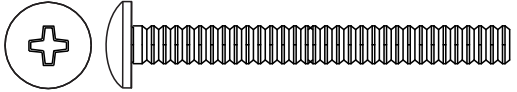
ID	IMAGEM DE REFERÊNCIA / IMAGE REFERENCE IMAGEN REFERENCIA	QUANTIDADE # OF PIECES CANTIDAD
A	 M6x20mm	04
B	 5,0x70mm	06
C		02
D	 1/4x11/2"	02

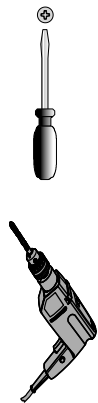

**1** Passo  
Step  
Paso

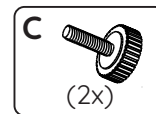
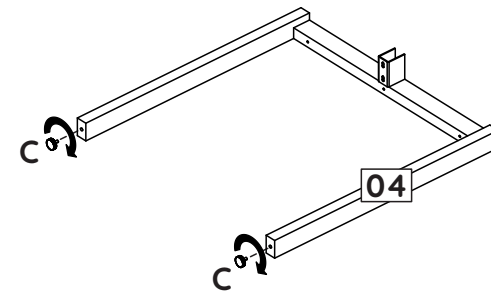

**2** Passo  
Step  
Paso

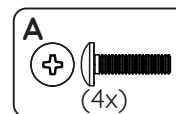
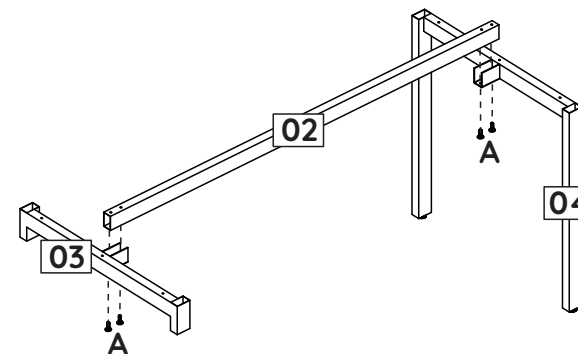

**3** Passo  
Step  
Paso

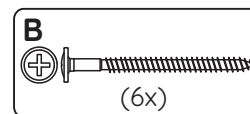
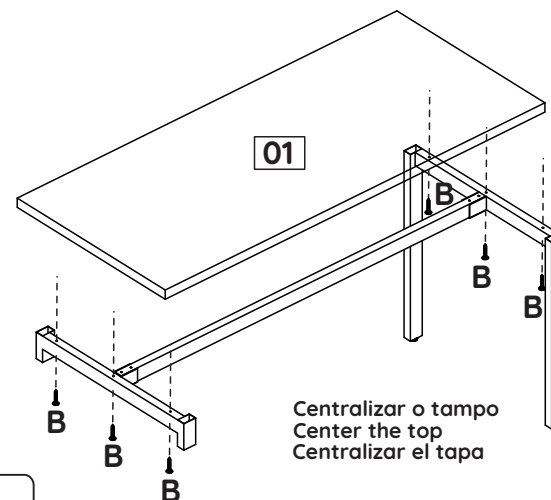
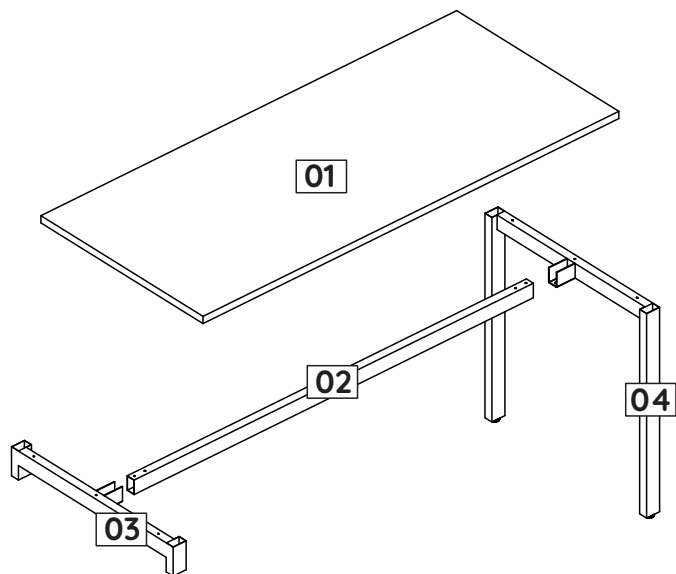

ID	Descrição / Description Denominación	Quantidade # Of Pieces Cantidad	Dimensão (mm) Dimension (mm) Dimensión (mm)
01	Tampo/Top/Tapa	01	1600x700x25
02	Longarina/Traverse/Travessaño	01	1532x50x30
03	Pé apoio/Support foot/Pata apoyo	01	700x100x50
04	Pé/Foot/Pata	01	700x725x150

**6** Passo  
Step  
Paso

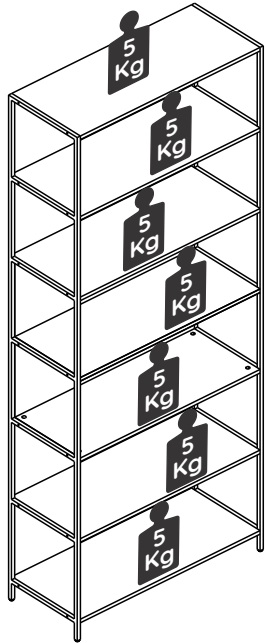

## INSTRUÇÕES DE MONTAGEM ASSEMBLY INSTRUCTIONS INSTRUCCIONES DE MONTAJE

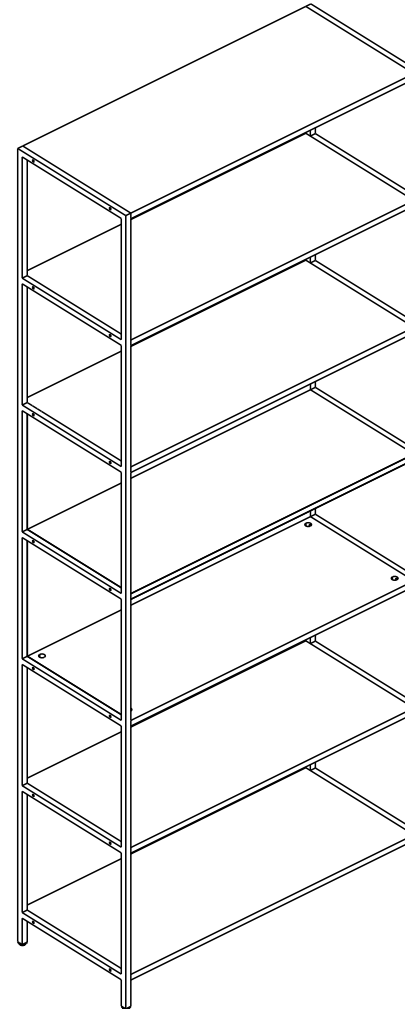

### Dicas de Conservação / Maintenance Tips / Consejos de Mantenimiento

\*Para limpar ou tirar manchas, utilize uma flanela umedecida em solução de água e álcool, na mesma proporção. Evite exposição ao sol.

\*To clean or remove stains, use a piece of flannel dampened with a water and alcohol solution, in the same proportion. Avoid direct sunlight.

\*Para limpiar o sacar manchas, utilice una flanela humedecida en solución de agua y alcohol, en la misma proporción. Evite la exposición directa al sol.









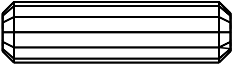

**REF. 25858**

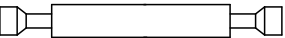

# FERRAGENS / HARDWARE LIST / LISTA DE HERRAJES

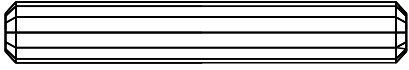
Os desenhos das ferragens são em escala real, então suas dimensões são iguais as das ferragens reais.  
 The hardware drawings are full-scale, so their dimensions are the same as the actual hardware.  
 Los dibujos de los herrajes son la escala real, por lo que sus dimensiones son las mismas que las del herraje real.

## 5 Passo Step Paso

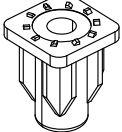
ID	IMAGEM DE REFERÊNCIA / IMAGE REFERENCE IMAGEN REFERENCIA	QUANTIDADE # OF PIECES CANTIDAD
A	 8x30mm	04
B		04
C		08
D		08
E		02
F		28
G	 8x50mm	02
H	 4,5x60mm	28
I	  1/4" x 30mm 	04

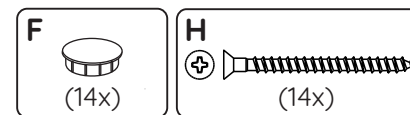
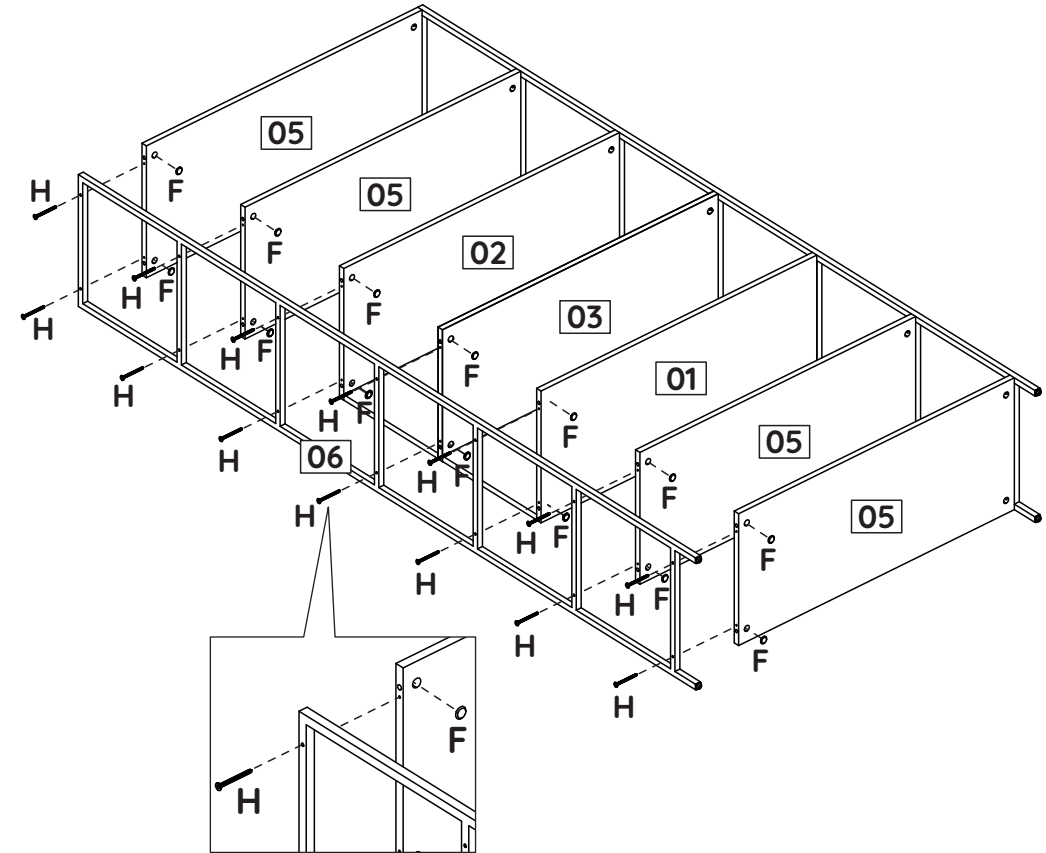

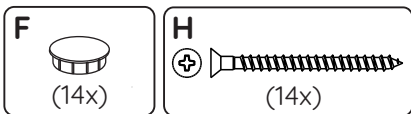
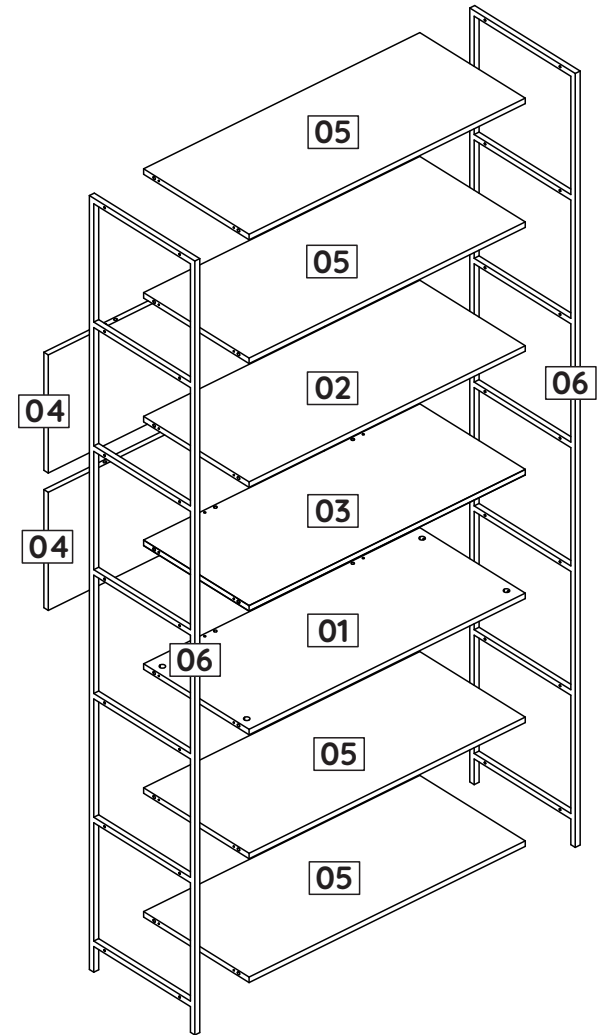
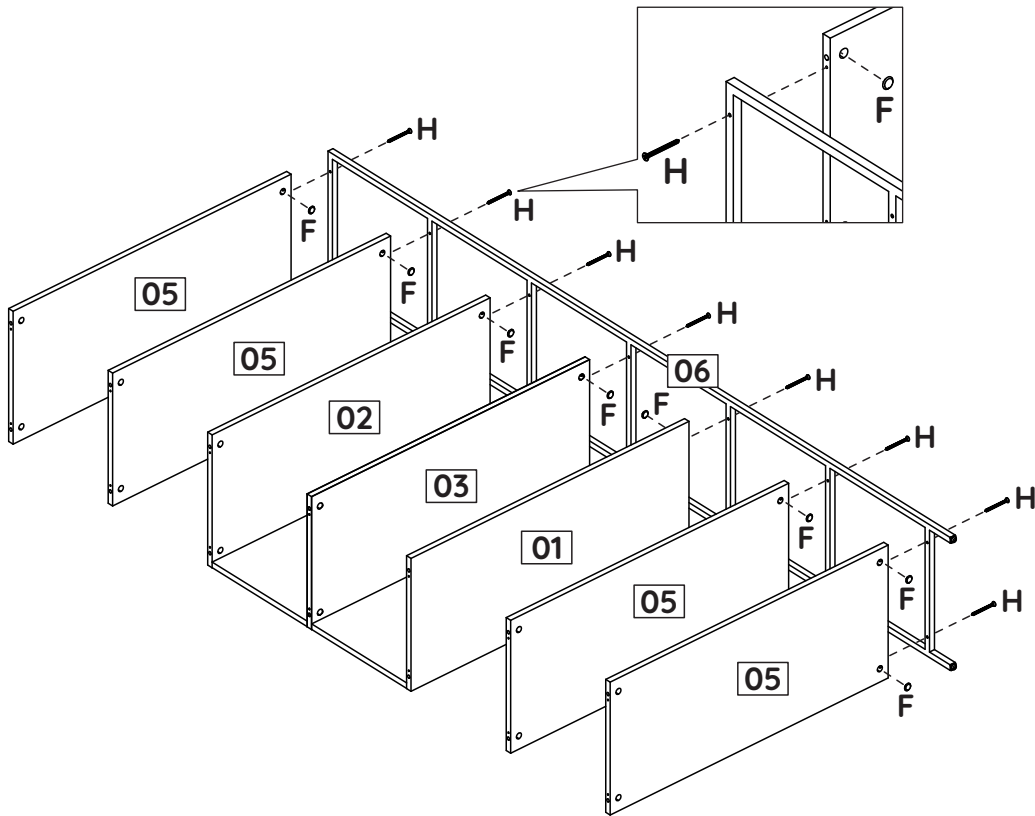

ID	Descrição / Description / Denominación	Quantidade # Of Pieces Cantidad	Dimensão (mm) Dimension (mm) Dimensión (mm)
01	Base/Base/Base	01	840x360x15
02	Tampo/Top/Tapa	01	840x360x15
03	Prateleira central/Center shelf/Repisa central	01	840x360x15
04	Costa/Back/Revés	02	840x360x15
05	Prateleira/Shelf/Repisa	04	840x360x15
06	Lateral metálica/Mettalic side/Lateral metálico	02	2110x360x15

**1** Passo Step Paso

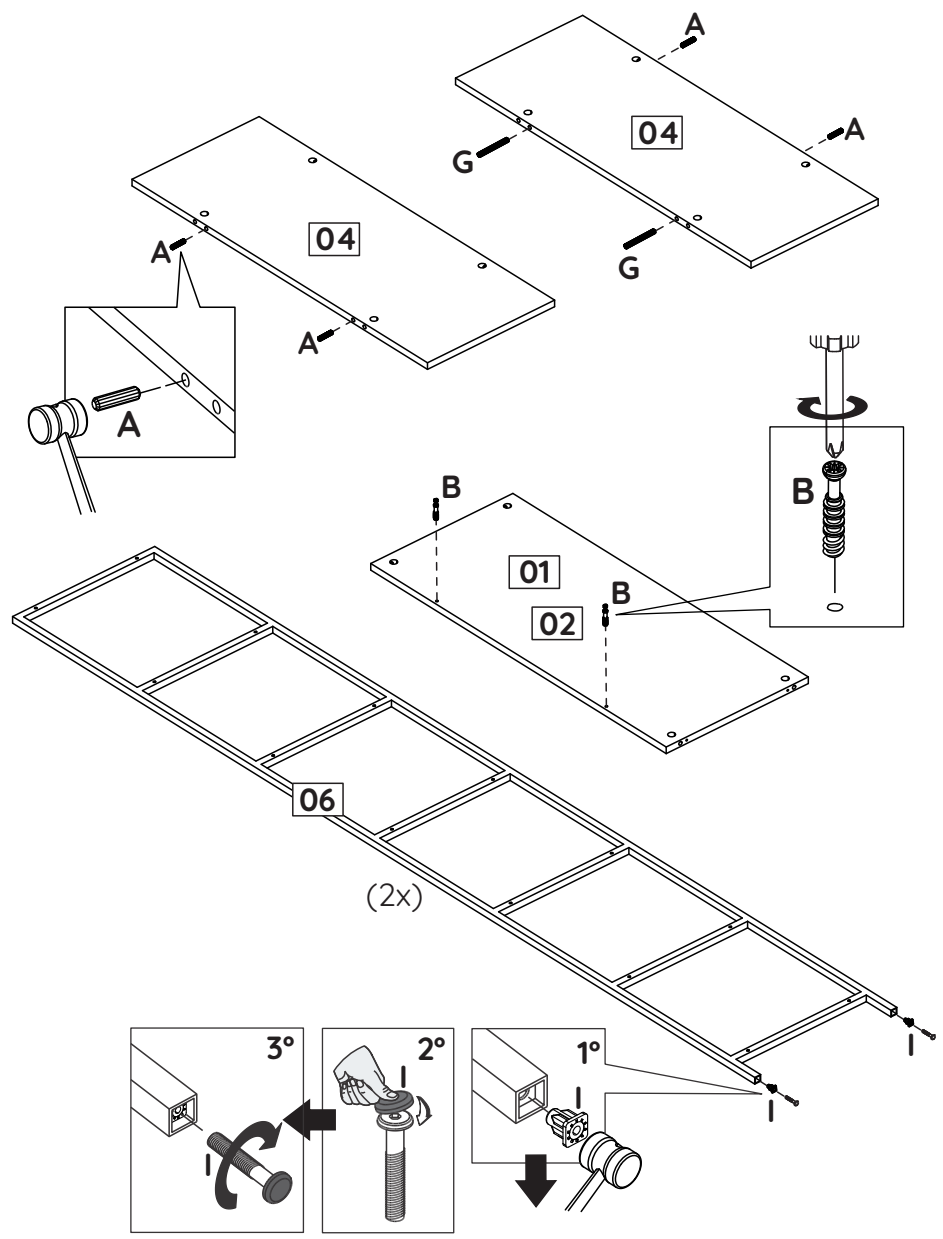

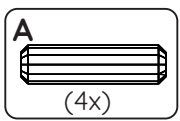
- 

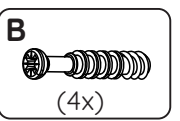
**A**  
(4x)
- 

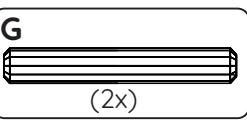
**B**  
(4x)
- 

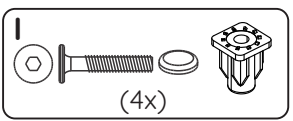
**G**  
(2x)
- 

**I**  
(4x)

**2** Passo Step Paso

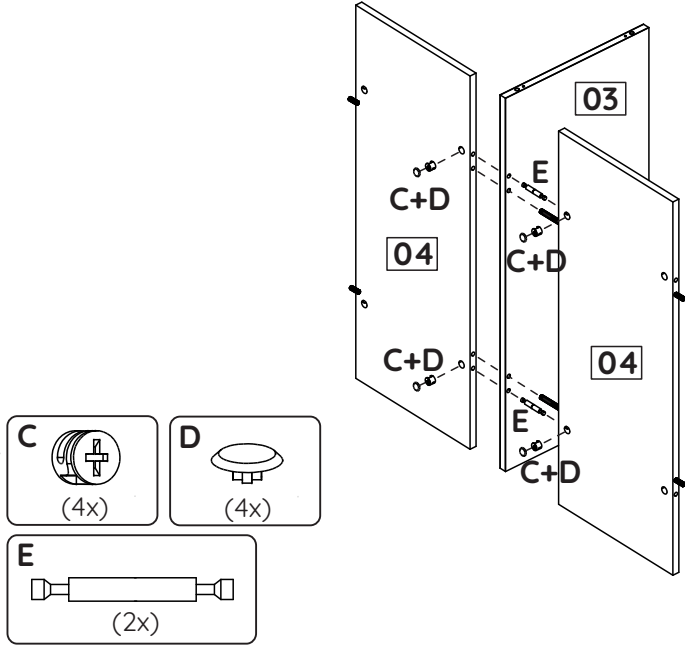

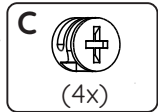
- 

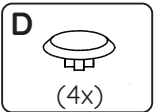
**C**  
(4x)
- 

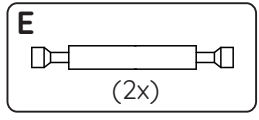
**D**  
(4x)
- 

**E**  
(2x)

**3** Passo Step Paso

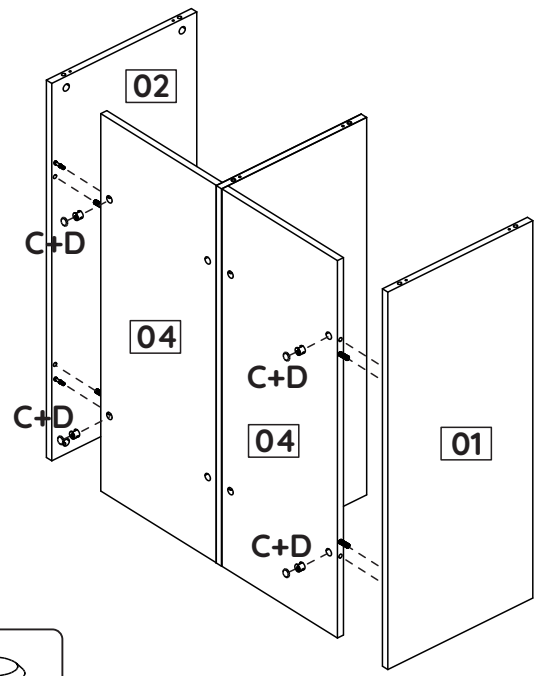

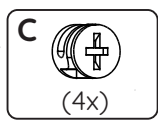
- 

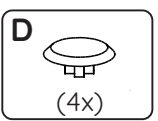
**C**  
(4x)
- 

**D**  
(4x)