

ASSEMBLY INSTRUCTIONS

Ref.: 200614 - ELB0036.001 | Review 01

INSTRUCTIONS DE MONTAGE | MANUAL DE ARMADO | ESQUEMA DE MONTAGEM

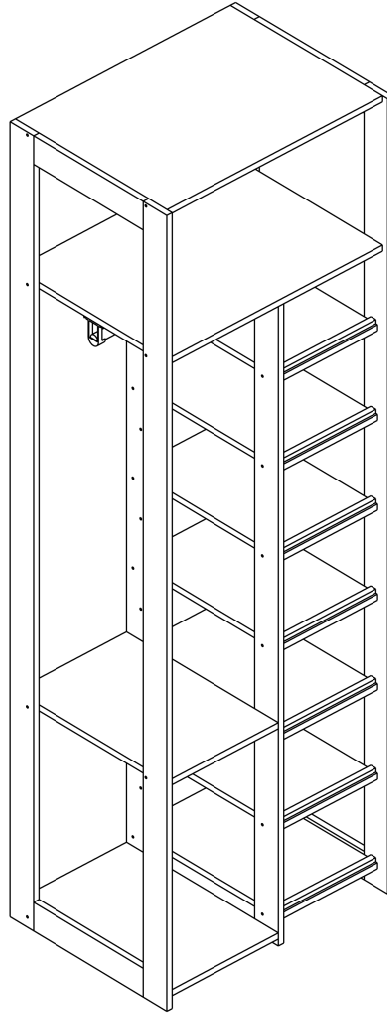

YOU WILL NEED

TU AURAS BESOIN DE | NECESITARÁ | VOCÊ VAI PRECISAR

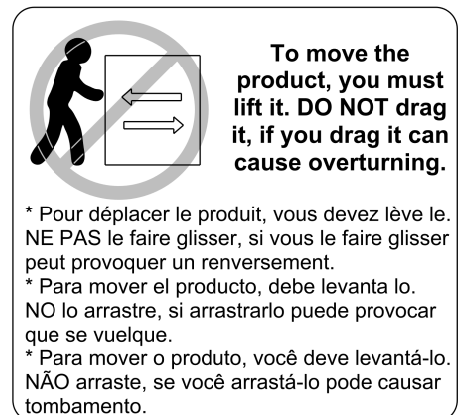
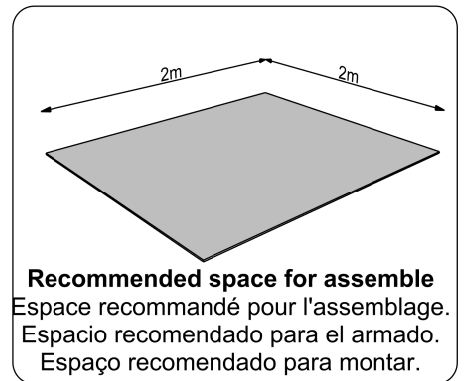
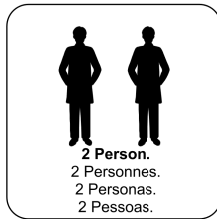
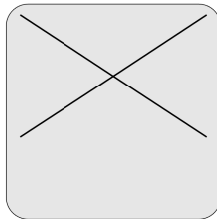
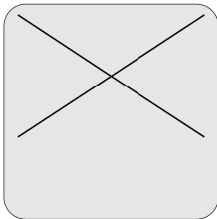
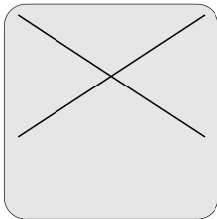
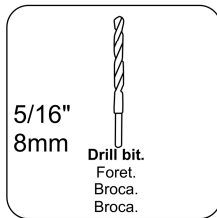
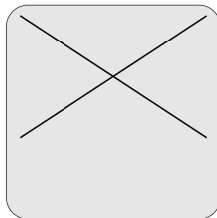
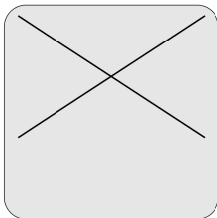
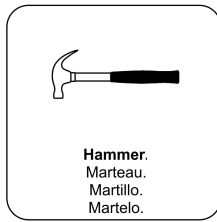
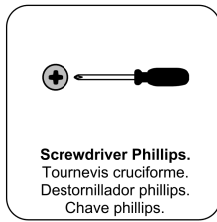
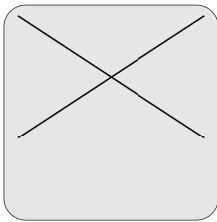
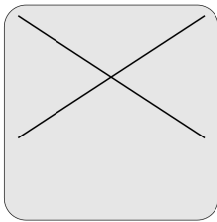

Tools not included

Outils non inclus | Herramientas no incluidas | Ferramentas não inclusas

PARTS IDENTIFICATION

IDENTIFICATION DES PIÈCES | IDENTIFICACIÓN DE PIEZAS | IDENTIFICAÇÃO DAS PEÇAS

01	Top Base Base Supérieure Base Superior Base Superior	Qty./Qtd. 01
02	Intermediate Base Base Intermédiaire Base Intermedia Base Intermediária	Qty./Qtd. 01
03	Base Base Base Base	Qty./Qtd. 02
04	Shelf Étagère Repisa Prateleira	Qty./Qtd. 07
05	Front Left Tray Plateau Gauche Avant Traviesa Izquierdo Frontal Travessa Esquerda Frontal	Qty./Qtd. 01
06	Rear Left Tray Plateau Gauche Arrière Traviesa Izquierdo Posterior Travessa Esquerda Traseira	Qty./Qtd. 01
07	Front Right Tray Plateau Droite Avant Traviesa Derecho Frontal Travessa Direita Frontal	Qty./Qtd. 01
08	Rear Right Tray Plateau Droite Arrière Traviesa Derecho Posterior Travessa Direita Traseira	Qty./Qtd. 01
09	Front Tray Plateau Avant Traviesa Frontal Travessa Frontal	Qty./Qtd. 01
10	Rear Tray Plateau Arrière Traviesa Posterior Travessa Traseira	Qty./Qtd. 01
11	Lateral Tray Plateau Latéral Traviesa Lateral Travessa Lateral	Qty./Qtd. 04
13	Backboard Panneau Fondo Trasero Costa	Qty./Qtd. 01

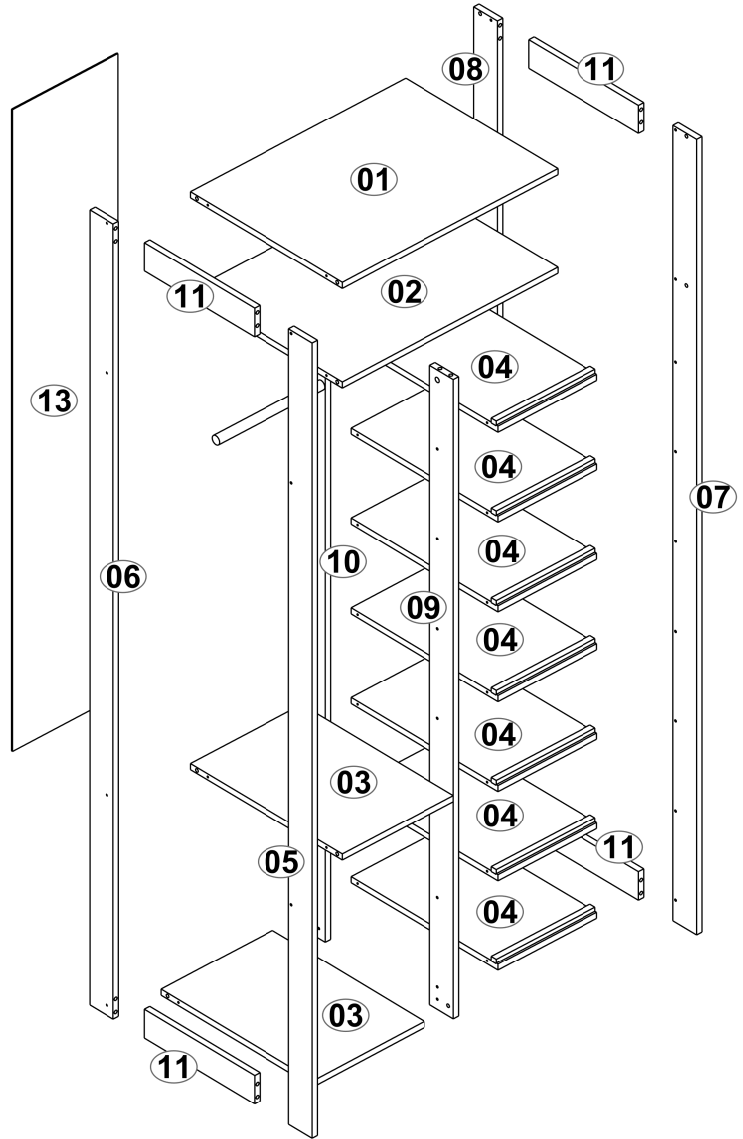

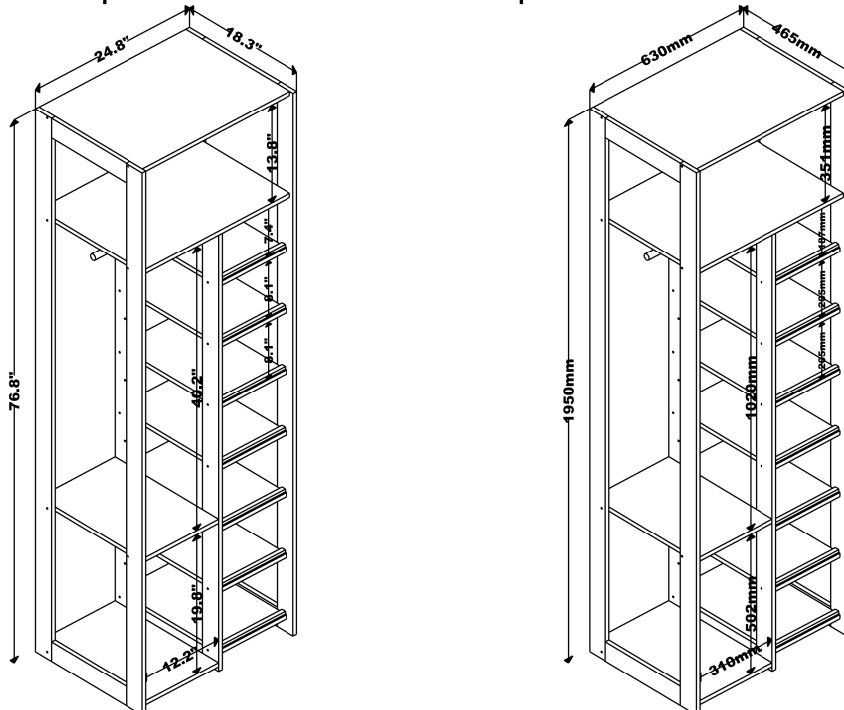

GENERAL DIMENSIONS | DIMENSIONS GÉNÉRALES | DIMENSIONES GENERALES | DIMENSÕES

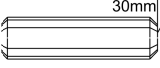

ACCESSORIES IDENTIFICATION

IDENTIFICATION DES ACCESSOIRES | IDENTIFICACIÓN DE ACCESORIOS | IDENTIFICAÇÃO DOS ACESSÓRIOS

A  Qty./Qtd. **34**
Wooden dowel / Chevilles en bois / Taquete / Caviha

AD  Qty./Qtd. **2**
Allen key / Clé Allen / Liave allen / Chave Allen

B  Qty./Qtd. **44**
Structural screw / Vis à tête structurelle / Tornillo estructural / Parafuso Estrutural

BS  Qty./Qtd. **2**
Support / Soutien / Soporte / Suporte

BT  Qty./Qtd. **4**
Pan head screw / Vis à tête bombée / Tornillo de pan / Parafuso Panela

BU  Qty./Qtd. **28**
Plastic hole plugs / Bouchons de trous en plastique / Tapones plásticos / Tapa furo plástico

F  Qty./Qtd. **44**
Structural screw cover/Cache-vis structurel/Tapa tornillo estructural/ Tampa estrutural

G  Qty./Qtd. **2**
Simple minifix screw / Vis minifix simple / Tornillo minifix simple / Haste Minifix Simples

H  Qty./Qtd. **2**
Drum lock / Verrouillage du tambour / Tambor minifix / Tambor de Minifix

i  Qty./Qtd. **2**
Bore patch adhesive / Adhésif de correction d'alésage / Tapones adhesivo/ Adesivo Tapa Furo

J  Qty./Qtd. **34**
Nail / Ongle / Clavo / Prego

N  Qty./Qtd. **2**
Pan head screw / Vis à tête bombée / Tornillo de pan / Parafuso Panela

R  Qty./Qtd. **1**
Metalic bracket / Support métallique / Soporte de metal / Suporte de Metal

S  Qty./Qtd. **1**
Bushing / Douille expansive / Tapón / Bucha Plástica

T  Qty./Qtd. **1**
Flanged head screw / Vis à tête bride / Tornillo de cabeza flangeada/ Parafuso flangeado

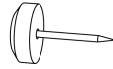
V  Qty./Qtd. **6**
Small plastic foot / Chaussure de glisse / Pie plástico / Sapata Plástica

Separating the accessories before starting the assembly will make it easier.
Séparer les accessoires avant de commencer le montage vous facilitera la tâche.
Separar los accesorios antes de comenzar el montaje lo hará más fácil.
Separar os acessórios antes de iniciar a montagem facilitará.

MAXIMUM RECOMMENDED WEIGHT BEING THIS EVENLY DISTRIBUTED.
LE POIDS MAXIMAL RECOMMANDÉ EST RÉGULIÈREMENT DISTRIBUÉ.
PESO MÁXIMO RECOMENDADO SIENDO ESTO UNIFORME REPARTIDO.
PESO MÁXIMO RECOMENDADO SENDO ESTE DISTRIBUIDO.

	LB	KG
A	44	20
B	11	5

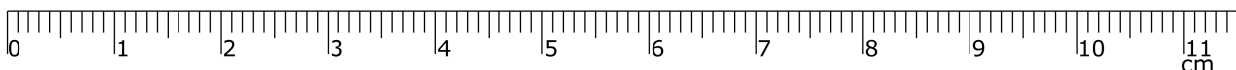
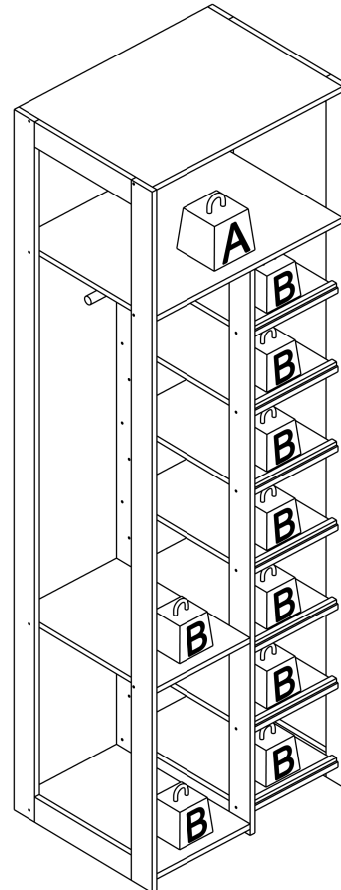

PRE-ASSEMBLY - PRÉ-ASSEMBLAGE - PRE-ARMADO PRÉ-MONTAGEM

- 01 - *Fix accessory (A) to part 01.
*Fixez l'accessoire (A) à la pièce 01.
*Fijar accesorio (A) a pieza 01.
*Fixe o acessório (A) na peça 01.

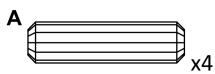
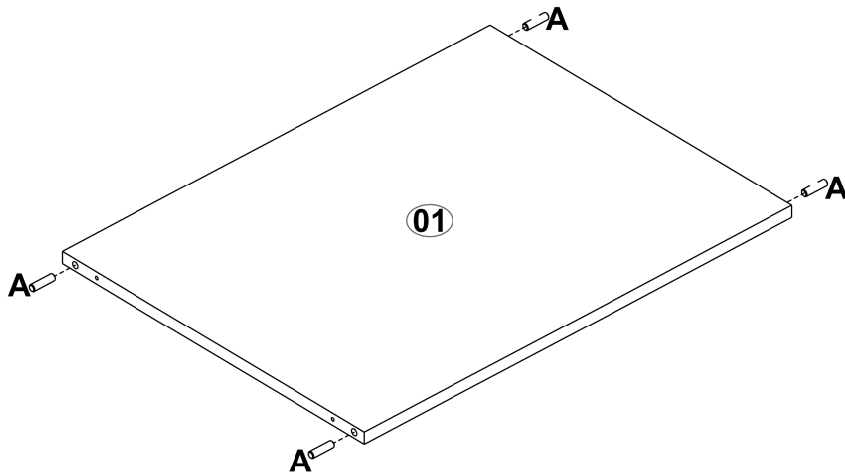
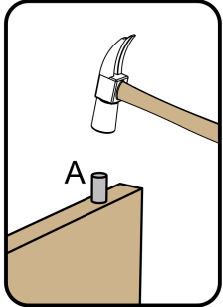

- 02 - *Fix accessory (A) to part 03.
*Fixez l'accessoire (A) à la pièce 03.
*Fijar accesorio (A) a pieza 03.
*Fixe o acessório (A) na peça 03.

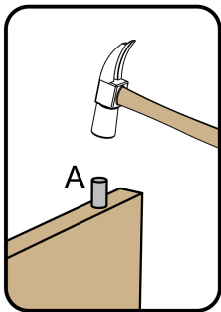

2x

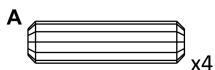
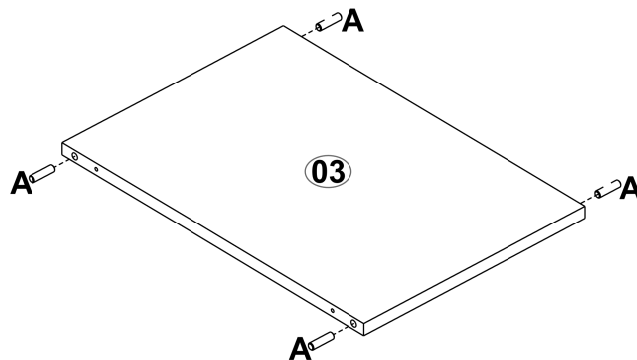

- 03 -** *Fix accessory (**A**) to part **02** and accessory (**BS**) with accessory (**N**).
 *Fixez l'accessoire (**A**) à la pièce **02** et l'accessoire (**BS**) avec l'accessoire (**N**).
 *Fijar accesorio (**A**) a pieza **02** y accesorio (**BS**) con el accesorio (**N**).
 *Fixe o acessório (**A**) na peça **02** e o acessório (**BS**) com o acessório (**N**).

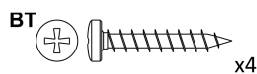
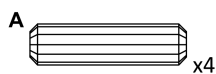
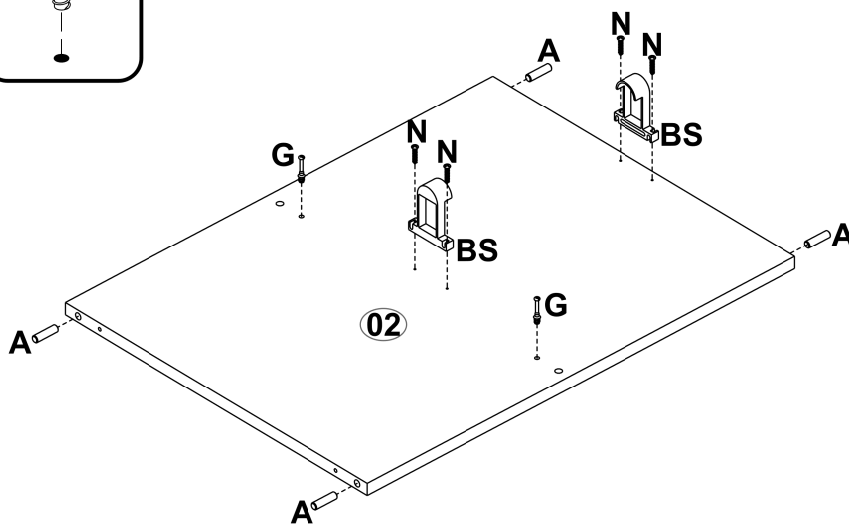
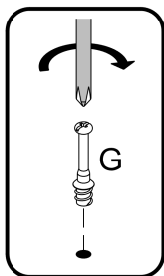
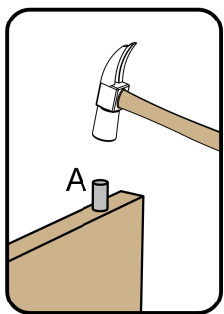

- 04 -** *Fix accessory (**A**) to part **11**.
 *Fixez l'accessoire (**A**) à la pièce **11**.
 *Fijar accesorio (**A**) a pieza **11**.
 *Fixe o acessório (**A**) na peça **11**.

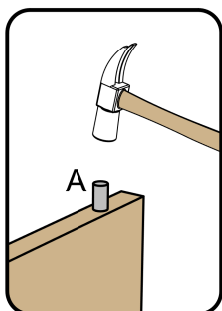

4x

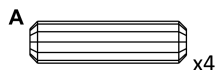
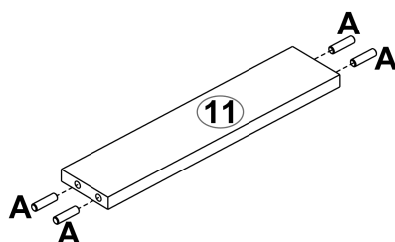

- 05 - *Fix accessory (**A**) to part ⑩.
*Fixez l'accessoire (**A**) à la pièce ⑩.
*Fijar accesorio (**A**) a pieza ⑩.
*Fixe o acessório (**A**) na peça ⑩.

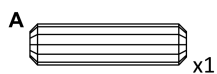
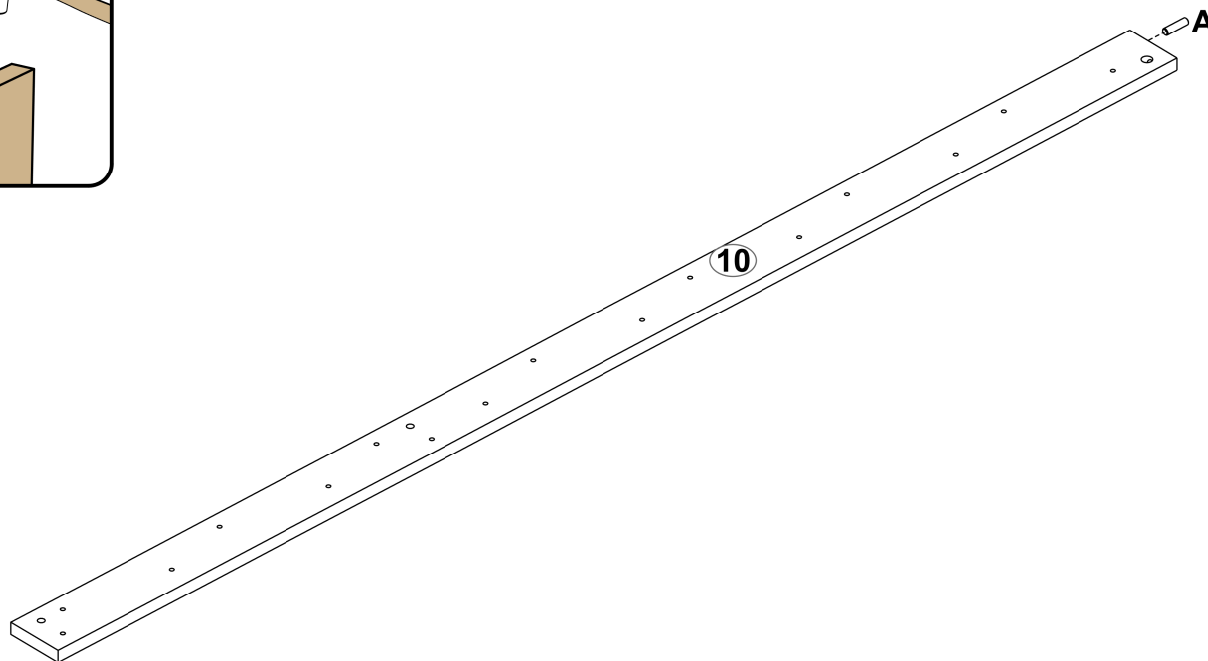
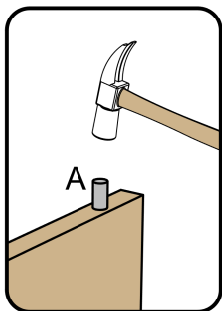

- 06 - *Fix accessory (**A**) to part ⑨.
*Fixez l'accessoire (**A**) à la pièce ⑨.
*Fijar accesorio (**A**) a pieza ⑨.
*Fixe o acessório (**A**) na peça ⑨.

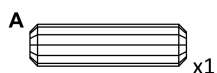
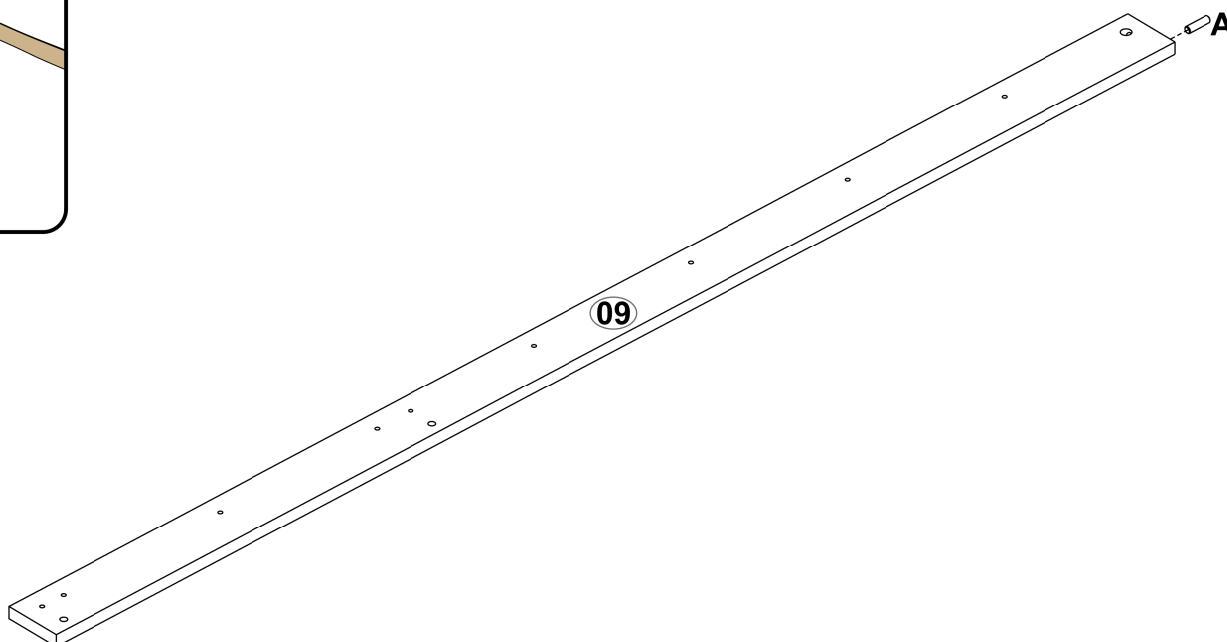
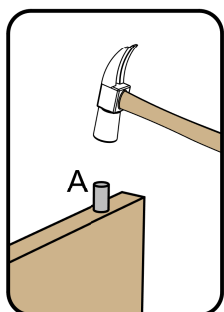

ASSEMBLY - MONTAGE - ARMADO - MONTAGEM

- 07 -** *Fix part **05**, part **06** and part **11**.
*Fixez la pièce **05**, la pièce **06** et la pièce **11**.
*Fijar pieza **05**, pieza **06** y pieza **11**.
*Fixe a peça **05**, a peça **06** e a peça **11**.

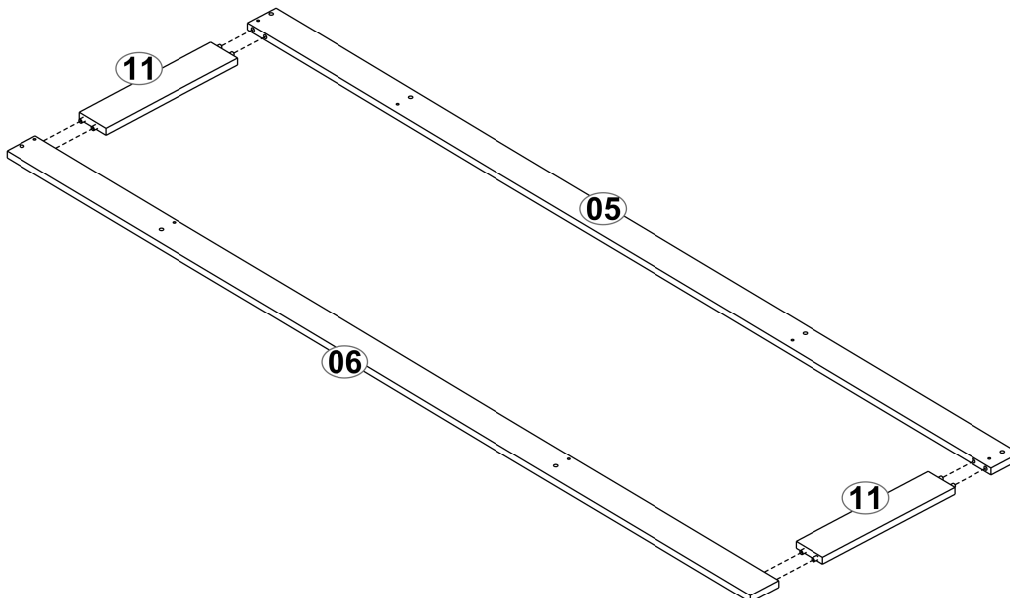

- 08 -** *Fix part **07**, part **08** and part **11**.
*Fixez la pièce **07**, la pièce **08** et la pièce **11**.
*Fijar pieza **07**, pieza **08** y pieza **11**.
*Fixe a peça **07**, a peça **08** e a peça **11**.

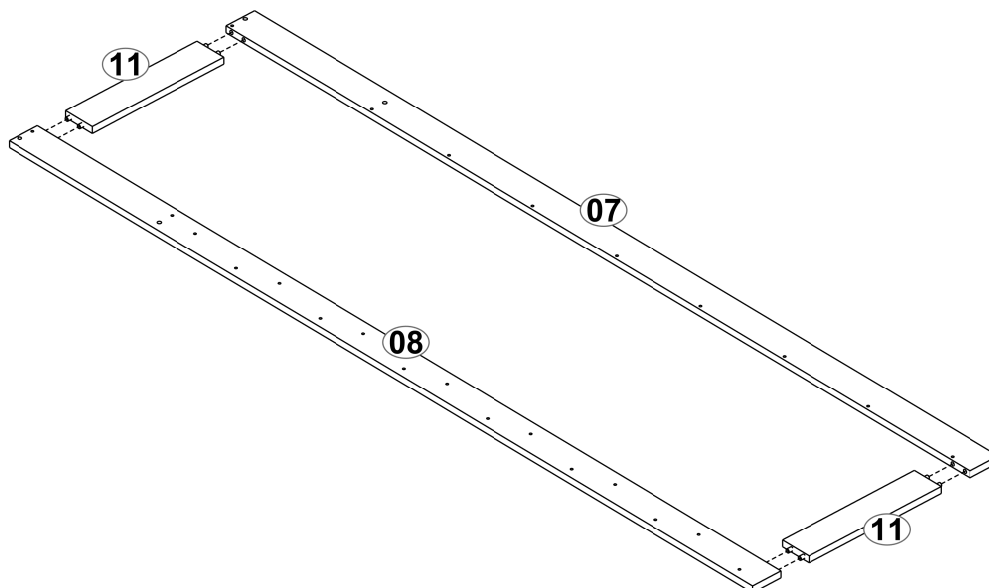

- 09** - *Fix part **09** and part **10** with the accessory (**B**) and part **02** with the accessory (**H**).
 *Fixez la pièce **09** ,et la pièce **10** avec l'accessoire (**B**) et la pièce **02** avec l'accessoire (**H**).
 *Fijar pieza **09** y pieza **10** con el accesorio (**B**) y pieza **02** con el accesorio (**H**).
 *Fixe a peça **09** e a peça **10** com o acessório (**B**) e a peça **02** com o acessório (**H**).

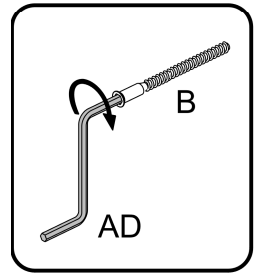
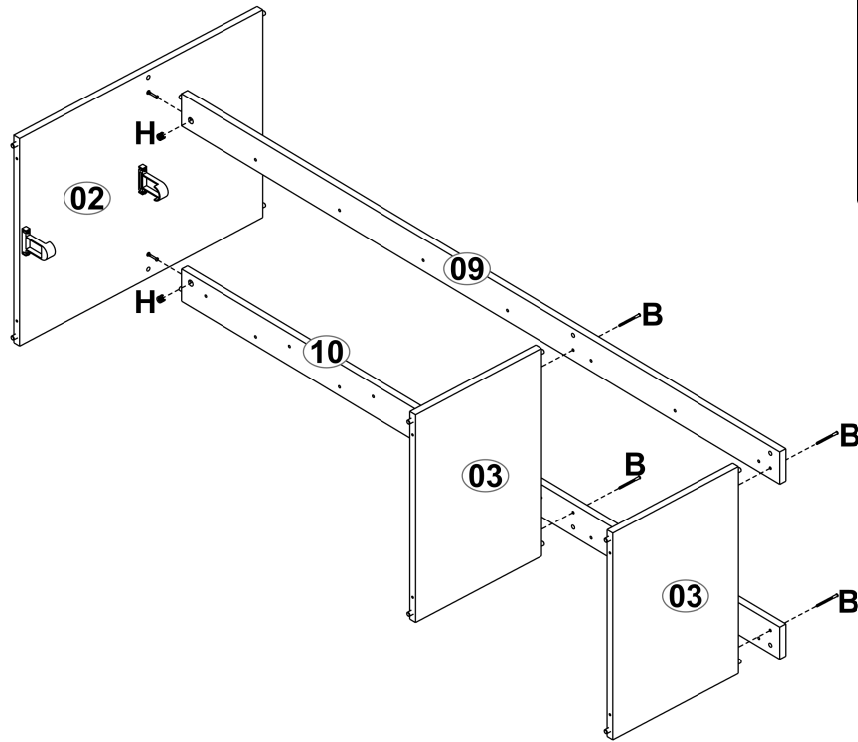
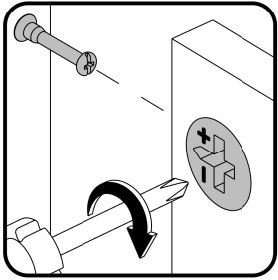

- 10** - *Fix part **04** to previous assembly with the accessory (**B**).
 *Fixez la pièce **04** à l'assemblage précédent avec l'accessoire (**B**).
 *Fijar pieza **04** a ensamble previo con el accesorio (**B**).
 *Fixe a peça **04** na montagem anterior com o acessório (**B**).

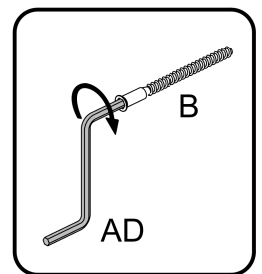
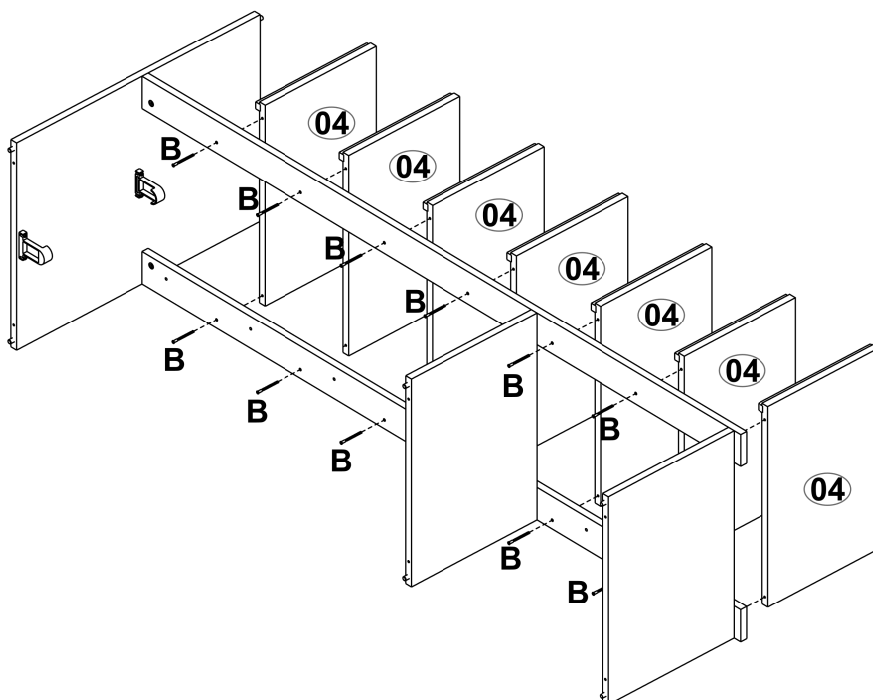

- 11 - *Fix previously assemblies (steps 07 and 10) and part 01 with the accessory (B).
 *Fixez assemblages précédents (étapes 07 et 10) et la pièce 01 avec l'accessoire (B).
 *Fijar ensambles previos (pasos 07 y 10) y pieza 10 con el accesorio (B).
 *Junte as montagens anteriores (passos 07 e 10) e a peça 01 com o acessório (B).

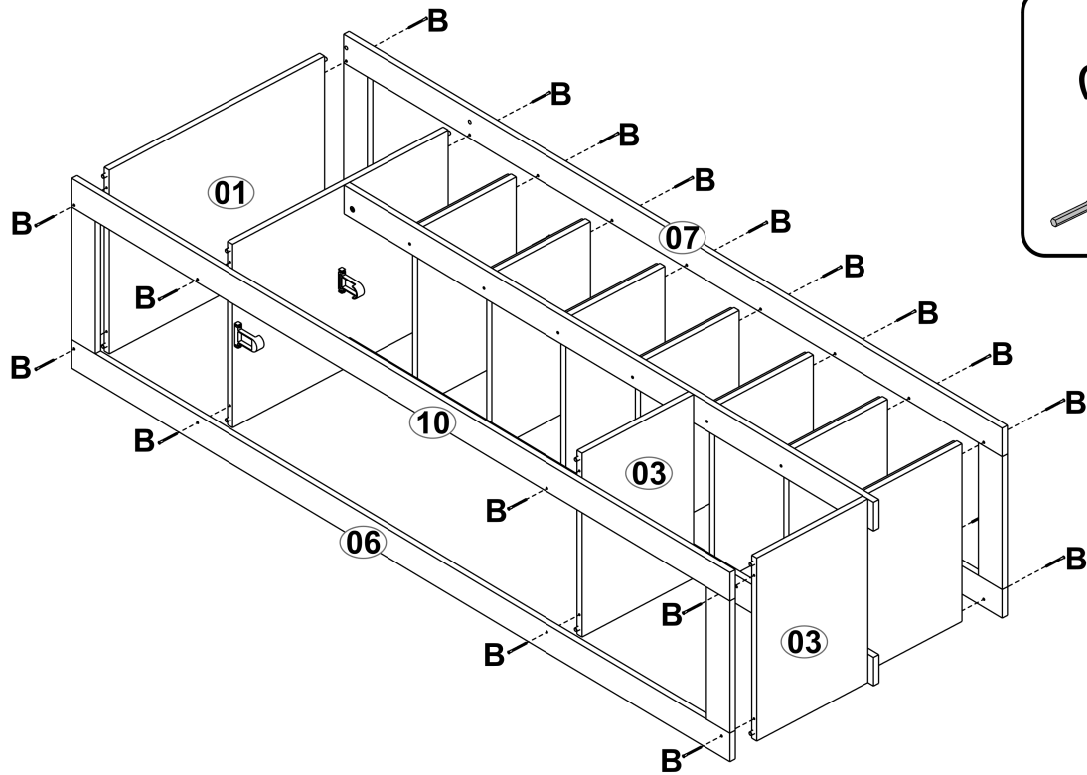

- 12 - *Fix part 13 to previous assembly with the accessory (J).
 *Fixez la pièce 13 à l'assemblage précédent avec l'accessoire (J).
 *Fijar pieza 13 a ensamble previo con el accesorio (J).
 *Fixe a peça 13 na montagem anterior com o acessório (J).

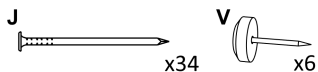
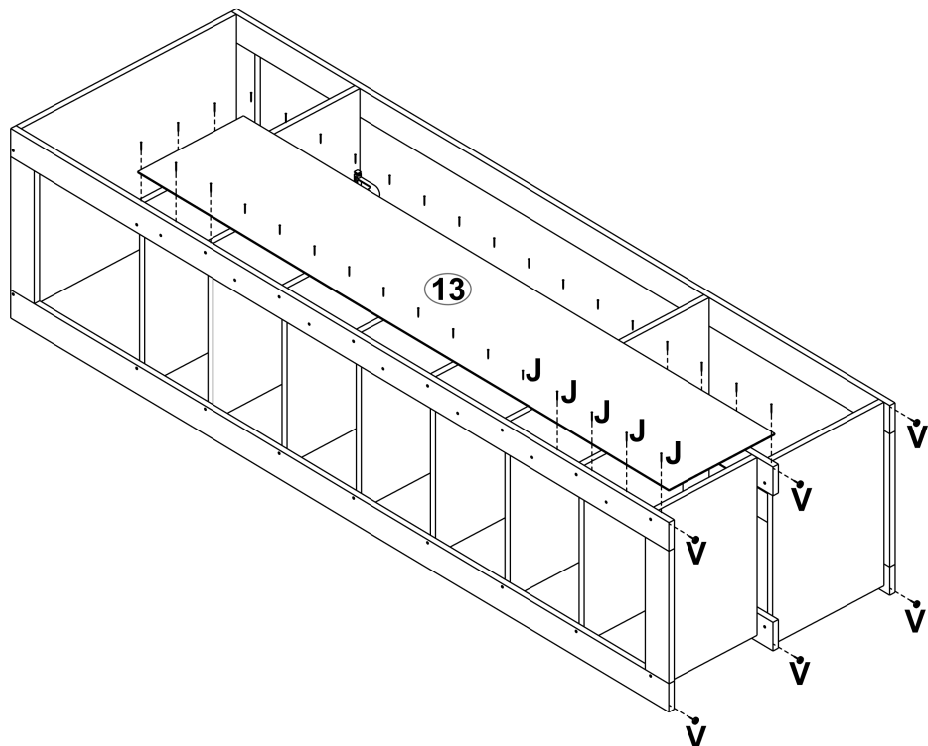

- 13 -** *Fix furniture to the wall with accessory (**S**) and accessory (**T**).
 *Fixez le meuble au mur avec l'accessoire (**S**) et l'accessoire (**T**).
 *Fijar mueble a la pared con el accesorio (**S**) y accesorio (**T**).
 *Fixe o móvel na parede com o acessório (**S**) e o acessório (**T**).

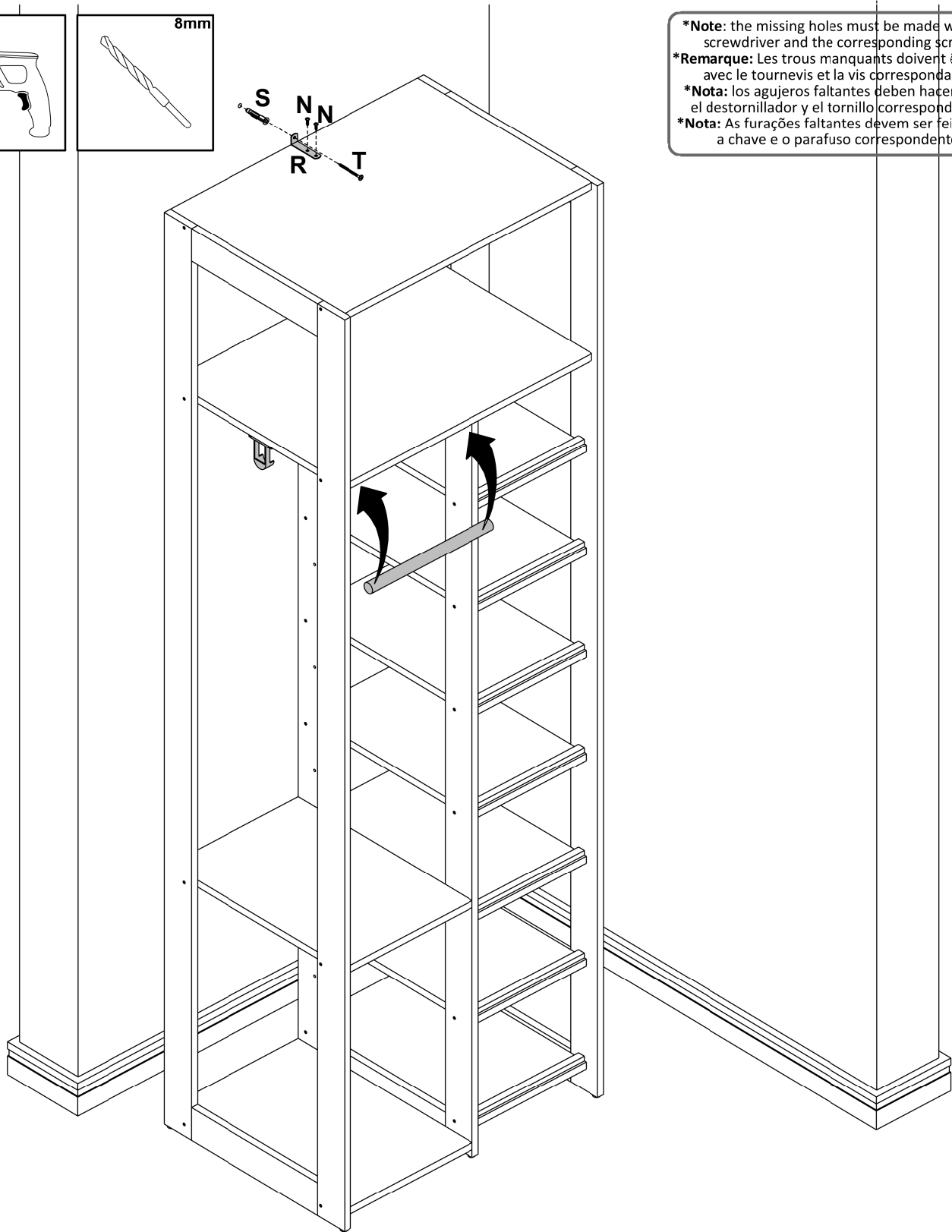
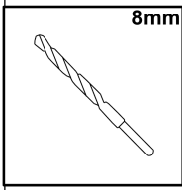
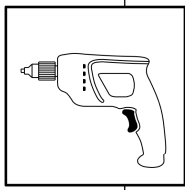

***Note:** the missing holes must be made with the screwdriver and the corresponding screw.
***Remarque:** Les trous manquants doivent être faits avec le tournevis et la vis correspondante.
***Nota:** los agujeros faltantes deben hacerse con el destornillador y el tornillo correspondiente.
***Nota:** As furações faltantes devem ser feitas com a chave e o parafuso correspondente.

***Note:** Use the stickers and caps to finish.
***Remarque:** Utiliser les autocollants et les capuchons pour terminer la finition.
***Nota:** Utilice los adhesivos y tapas para finalizar el acabado.
***Nota:** Utilize os adesivos e tampas para finalizar o acabamento.

