

# ASSEMBLY INSTRUCTIONS

Ref.: 200621 - ELB0038.001 Review 01

INSTRUCTIONS DE MONTAGE | MANUAL DE ARMADO | ESQUEMA DE MONTAGEM

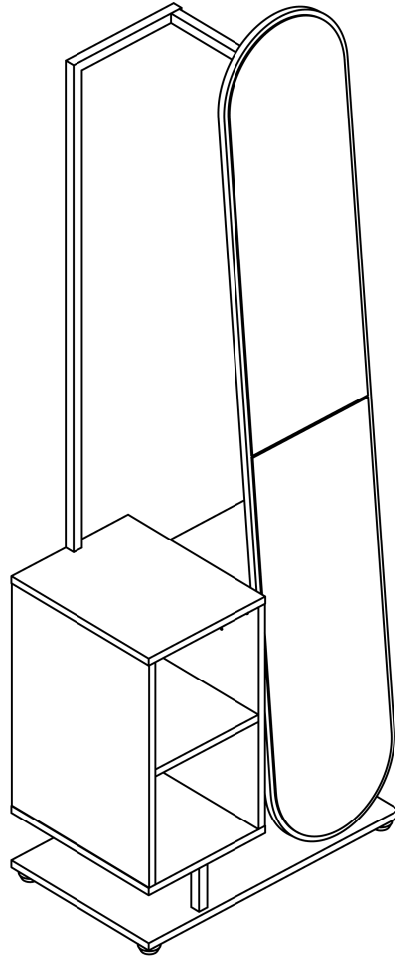

## YOU WILL NEED

TU AURAS BESOIN DE | NECESITARÁ | VOCÊ VAI PRECISAR

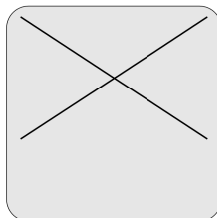
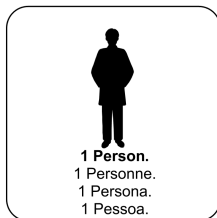
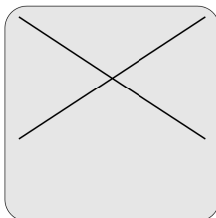
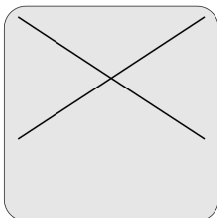
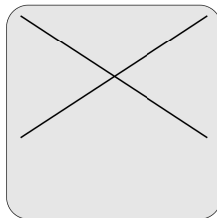
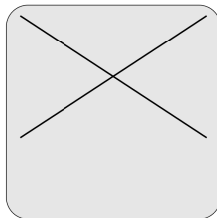
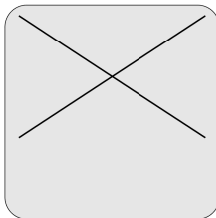
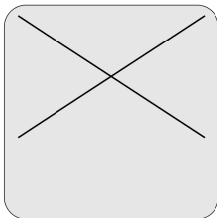
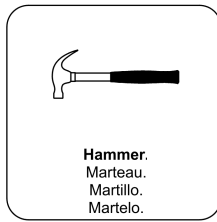
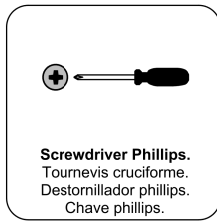
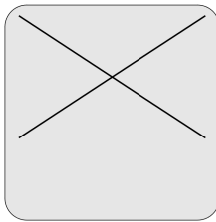
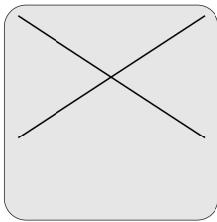

## Tools not included

Outils non inclus | Herramientas no incluidas | Ferramentas não inclusas

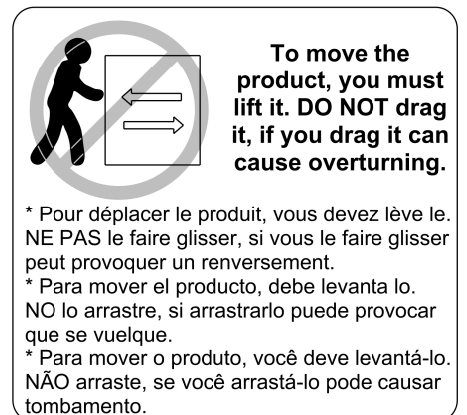
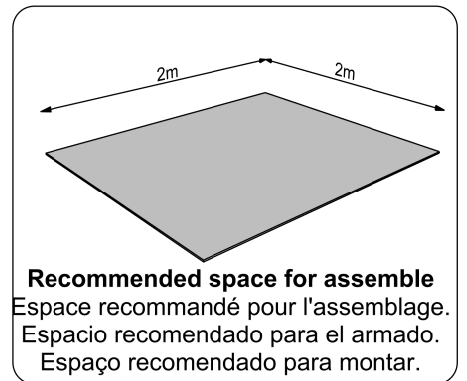

# PARTS IDENTIFICATION

IDENTIFICATION DES PIÈCES | IDENTIFICACIÓN DE PIEZAS | IDENTIFICAÇÃO DAS PEÇAS

<b>01</b>	Top Plan de Travail Tapa Tampo	Qty./Qtd. <b>01</b>
<b>02</b>	Shelf Étagère Repisa Prateleira	Qty./Qtd. <b>01</b>
<b>03</b>	Base Base Base Base	Qty./Qtd. <b>01</b>
<b>04</b>	Right Base Base Droite Base Derecha Base Direita	Qty./Qtd. <b>01</b>
<b>05</b>	Side Shelf Étagère Latérale Repisa Lateral Prateleira Lateral	Qty./Qtd. <b>01</b>
<b>06</b>	Bottom holder Support Inférieur Titular Inferior Suporte Inferior	Qty./Qtd. <b>01</b>
<b>07</b>	Bottom Base Base Inférieure Base Inferior Base Inferior	Qty./Qtd. <b>01</b>
<b>08</b>	Left Side Côté Gauche Lateral Izquierdo Lateral Esquerda	Qty./Qtd. <b>01</b>
<b>09</b>	Right Side Côté Droite Lateral Derecho Lateral Direita	Qty./Qtd. <b>01</b>
<b>10</b>	Side Côté Lateral Lateral	Qty./Qtd. <b>01</b>
<b>11</b>	Panel Panneau Panel Painel	Qty./Qtd. <b>01</b>
<b>12</b>	Backboard Panneau Fondo Trasero Costa	Qty./Qtd. <b>01</b>

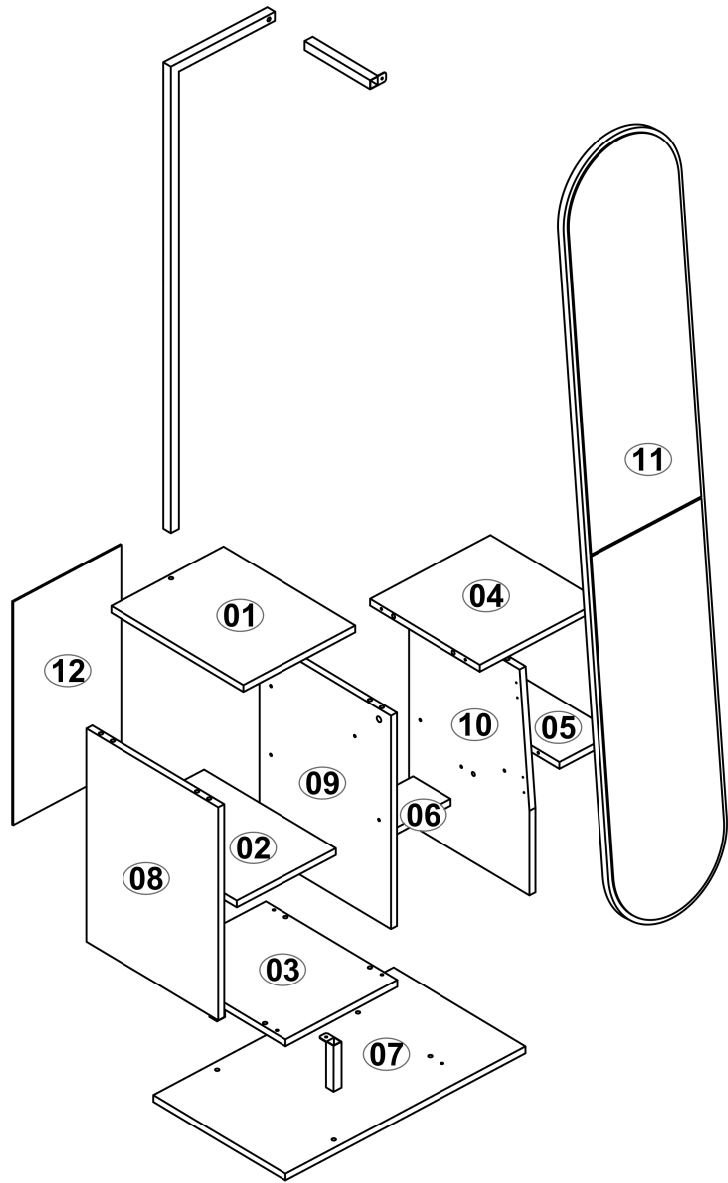

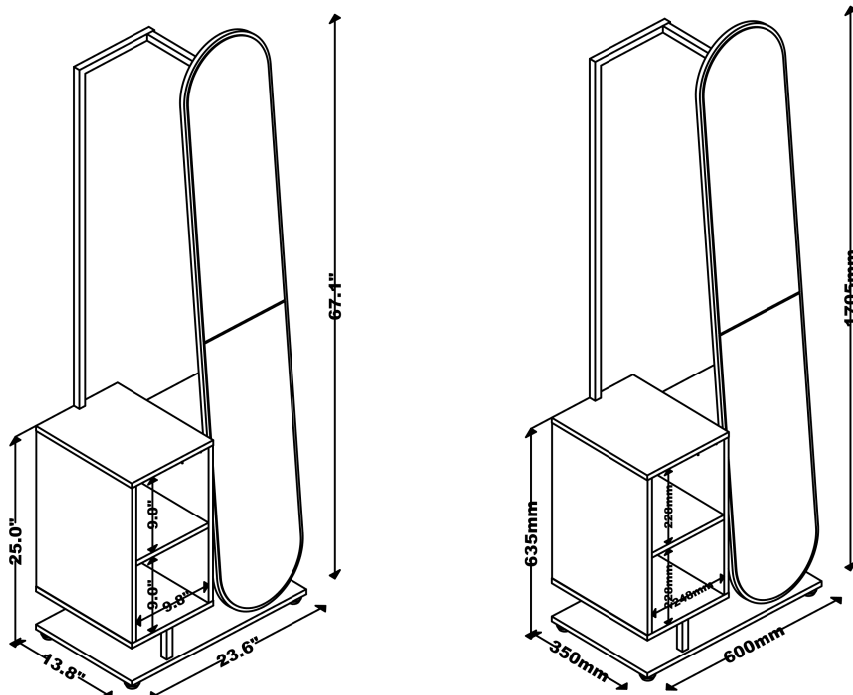

## GENERAL DIMENSIONS | DIMENSIONS GÉNÉRALES | DIMENSIONES GENERALES | DIMENSÕES



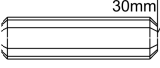

# ACCESSORIES IDENTIFICATION

IDENTIFICATION DES ACCESSOIRES | IDENTIFICACIÓN DE ACCESORIOS | IDENTIFICAÇÃO DOS ACESSÓRIOS

**A**  Qty./Qtd. **18**  
 30mm  
 Wooden dowel / Chevilles en bois / Taquete / Caviha

**AD**  Qty./Qtd. **1**  
 Allen key / Clé Allen / Liave allen / Chave Allen

**B**  Qty./Qtd. **12**  
 50mm  
 Structural screw / Vis à tête structurelle / Tornillo estructural / Parafuso Estrutural

**BB**  Qty./Qtd. **4**  
 Shelf support / Support d'étagère / Soporte de estantería / Suporte prateleira

**BC**  Qty./Qtd. **4**  
 Plastic foot / Pied en Plastique / Pie plástico / Sapata Plástica

**BM**  Qty./Qtd. **1**  
 Cover / Couvertres / Tapa / Tampa

**BN**  Qty./Qtd. **4**  
 Screw / Vis / Tornillo / Parafuso

**BT**  Qty./Qtd. **4**  
 20mm  
 Pan head screw / Vis à tête bombée / Tornillo de pan / Parafuso Panela

**F**  Qty./Qtd. **12**  
 Structural screw cover/Cache-vis structurel/Tapa tornillo estructural/ Tampa estrutural

**G**  Qty./Qtd. **6**  
 Simple minifix screw / Vis minifix simple / Tornillo minifix simple / Haste Minifix Simples

**H**  Qty./Qtd. **6**  
 Drum lock / Verrouillage du tambour / Tambor minifix / Tambor de Minifix

**i**  Qty./Qtd. **6**  
 Bore patch adhesive / Adhésif de correction d'alésage / Tapones adhesivo/ Adesivo Tapa Furo

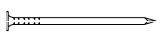
**J**  Qty./Qtd. **14**  
 10 x 10  
 Nail / Ongle / Clavo / Prego

**M**  Qty./Qtd. **4**  
 Metalic angle plates / Support métallique / Suporte de metal / Cantoneira de Metal

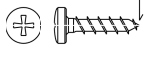
**N**  Qty./Qtd. **19**  
 14mm  
 Pan head screw / Vis à tête bombée / Tornillo de pan / Parafuso Panela

**Separating the accessories before starting the assembly will make it easier.**  
 Séparer les accessoires avant de commencer le montage vous facilitera la tâche.  
 Separar los accesorios antes de comenzar el montaje lo hará más fácil.  
 Separar os acessórios antes de iniciar a montagem facilitará.

**MAXIMUM RECOMMENDED WEIGHT BEING THIS EVENLY DISTRIBUTED.**  
 LE POIDS MAXIMAL RECOMMANDÉ EST RÉGULIÈREMENT DISTRIBUÉ.  
 PESO MÁXIMO RECOMENDADO SIENDO ESTO UNIFORME REPARTIDO.  
 PESO MÁXIMO RECOMENDADO SENDO ESTE DISTRIBUIDO.

	LB	KG
<b>A</b>	22	10

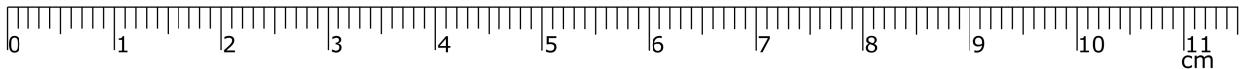
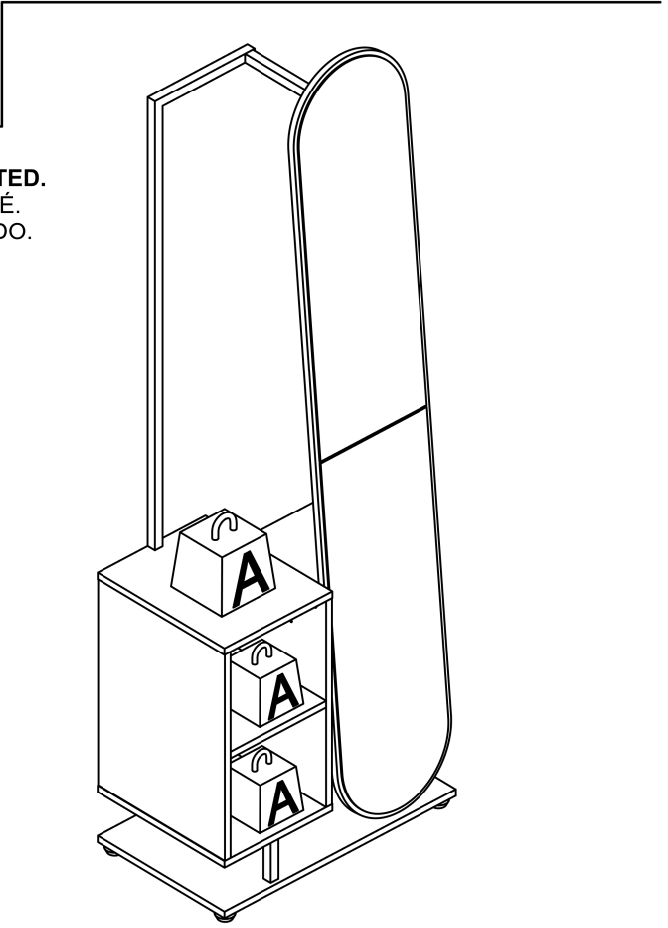

# PRE-ASSEMBLY - PRÉ-ASSEMBLAGE - PRE-ARMADO PRÉ-MONTAGEM

- 01** - \*Fix accessory ( **A** ) and accessory ( **BB** ) to part **08**.  
\*Fixez l'accessoire ( **A** ) et l'accessoire ( **BB** ) à la pièce **08**.  
\*Fijar accesorio ( **A** ) y accesorio ( **BB** ) a pieza **08**.  
\*Fixe o acessório ( **A** ) e o acessório ( **BB** ) na peça **08**.

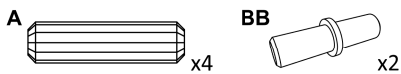
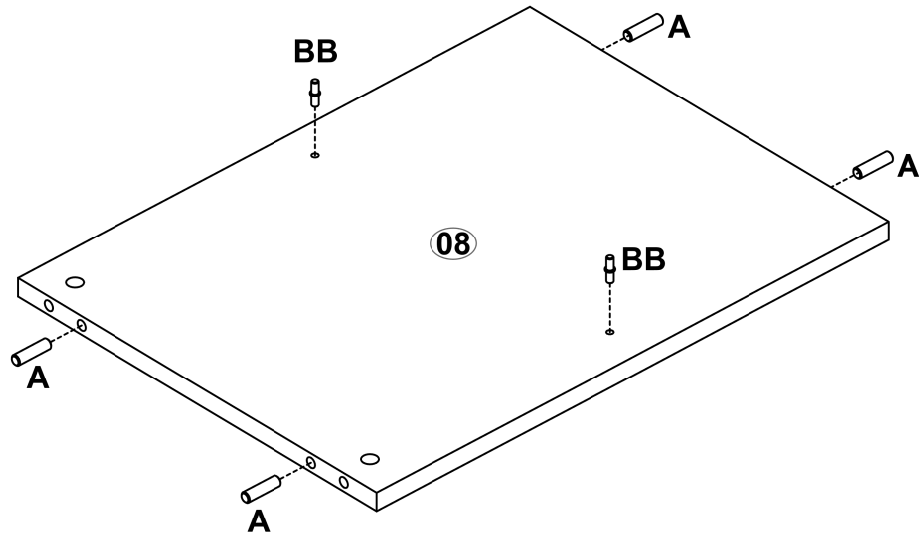
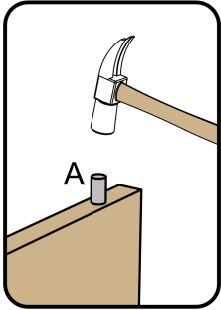

- 02** - \*Fix accessory ( **G** ) to part **01**.  
\*Fixez l'accessoire ( **G** ) à la pièce **01**.  
\*Fijar accesorio ( **G** ) a pieza **01**.  
\*Fixe o acessório ( **G** ) na peça **01**.

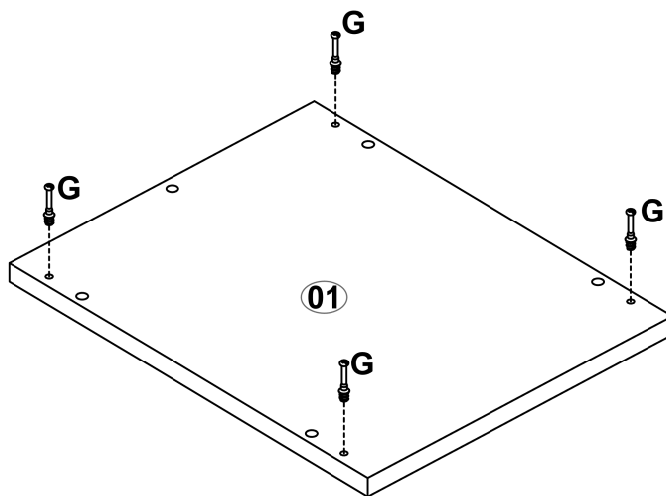
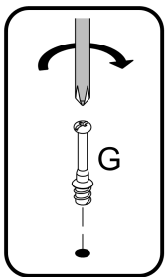

- 03 -** \*Fix accessory ( **G** ) to part **04** and accessory ( **M** ) with accessory ( **N** ).  
 \*Fixez l'accessoire ( **G** ) à la pièce **04** et l'accessoire ( **M** ) avec l'accessoire ( **N** ).  
 \*Fijar accesorio ( **G** ) a peça **04** y accesorio ( **M** ) con el accesorio ( **N** ).  
 \*Fixe o acessório ( **G** ) na peça **04** e o acessório ( **M** ) com o acessório ( **N** ).

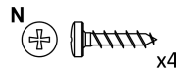
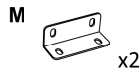
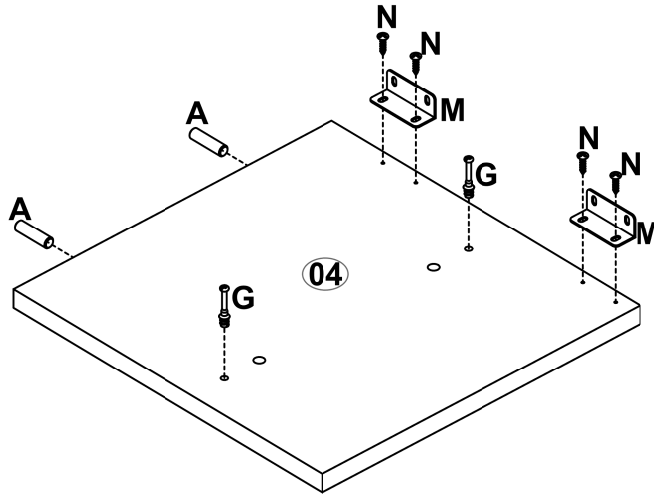
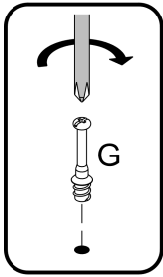
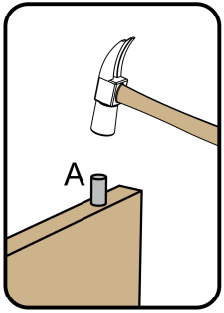

- 04 -** \*Fix accessory ( **BC** ) with accessory ( **BT** ) to part **07**.  
 \*Fixez l'accessoire ( **BC** ) avec l'accessoire ( **BT** ) à la pièce **07**.  
 \*Fijar accesorio ( **BC** ) con accesorio ( **BT** ) a peça **07**.  
 \*Fixe o acessório ( **BC** ) com o acessório ( **BT** ) na peça **07**.

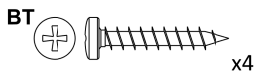
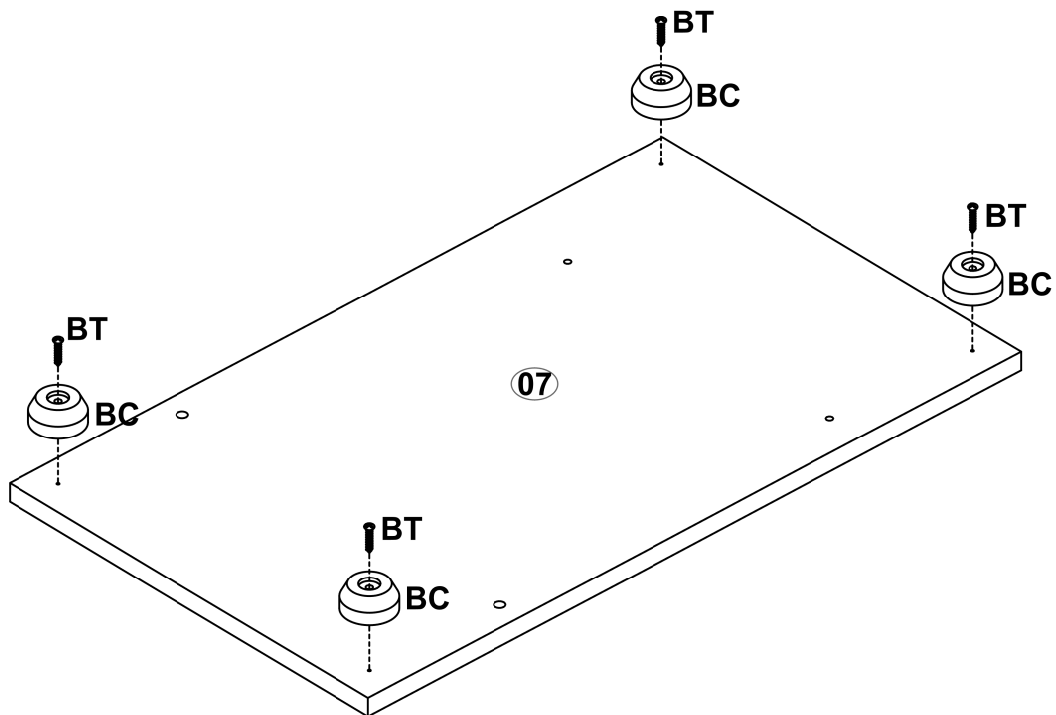

- 05** - \*Fix accessory (BB) and accessory ( A ) to part 09.  
 \*Fixez l'accessoire (BB) et l'accessoire ( A ) à la pièce 09.  
 \*Fijar accesorio (BB) y accesorio ( A ) a pieza 09.  
 \*Fixe o acessório (BB) e o acessório ( A ) na peça 09.

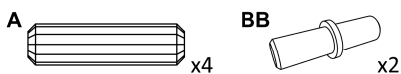
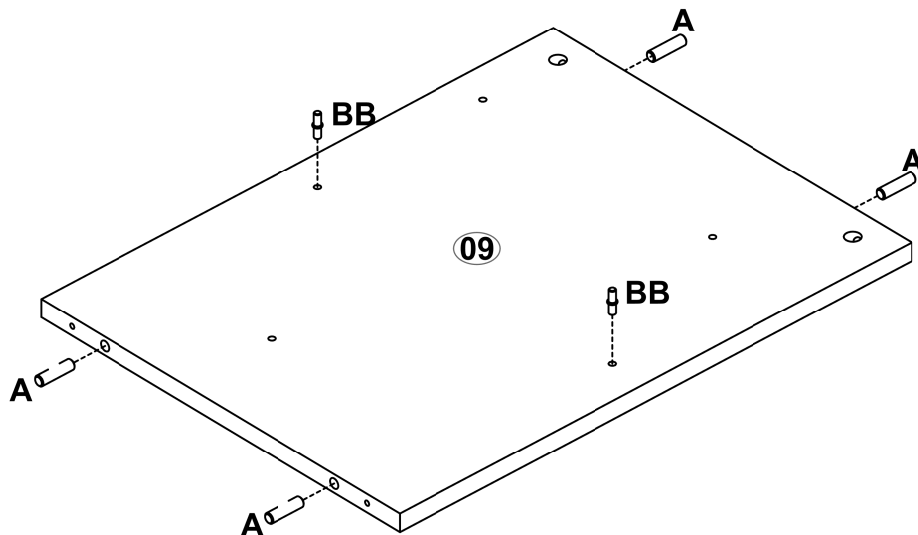
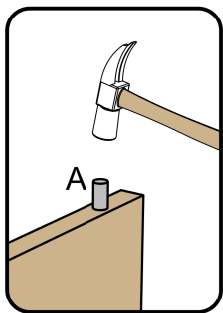

- 06** - \*Fix accessory ( A ) to part 10 and accessory ( M ) with accessory ( N ).  
 \*Fixez l'accessoire ( A ) à la pièce 10 et l'accessoire ( M ) avec l'accessoire ( N ).  
 \*Fijar accesorio ( A ) a pieza 10 y accesorio ( M ) con el accesorio ( N ).  
 \*Fixe o acessório ( A ) na peça 10 e o acessório ( M ) com o acessório ( N ).

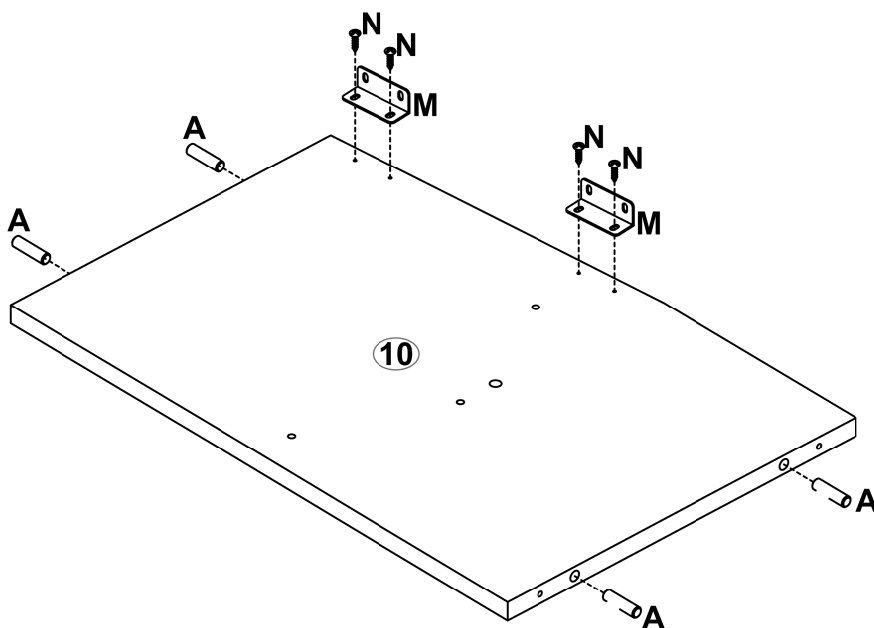
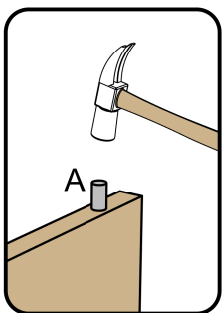

- 07 - \*Fix accessory ( **A** ) to part 06.  
\*Fixez l'accessoire ( **A** ) à la pièce 06.  
\*Fijar accesorio ( **A** ) a pieza 06.  
\*Fixe o acessório ( **A** ) na peça 06.

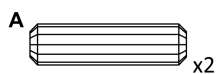
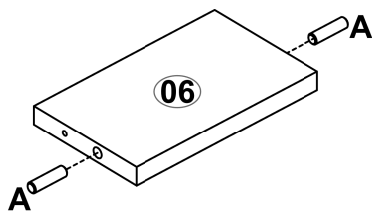
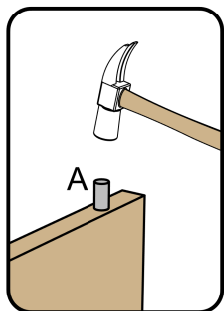

- 08 - \*Fix accessory ( **A** ) to part 05.  
\*Fixez l'accessoire ( **A** ) à la pièce 05.  
\*Fijar accesorio ( **A** ) a pieza 05.  
\*Fixe o acessório ( **A** ) na peça 05.

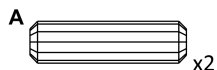
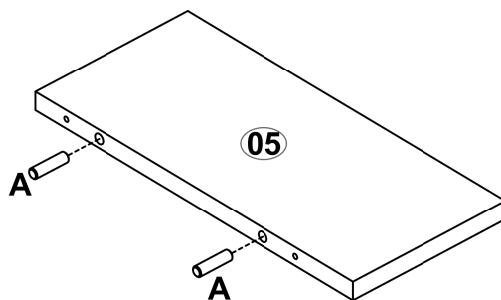
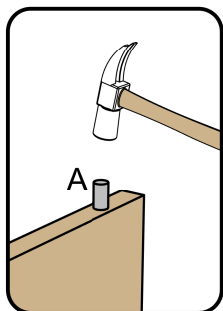

# ASSEMBLY - MONTAGE - ARMADO - MONTAGEM

- 09 - \*Fix part 06 and part 05 with the accessory ( B ) and part 04 with the accessory ( H ).  
\*Fixez la pièce 06, et la pièce 05 avec l'accessoire ( B ) et la pièce 04 avec l'accessoire ( H ).  
\*Fijar pieza 06 y pieza 05 con el accesorio ( B ) y pieza 04 con el accesorio ( H ).  
\*Fixe a peça 06 e a peça 05 com o acessório ( B ) e a peça 04 com o acessório ( H ).

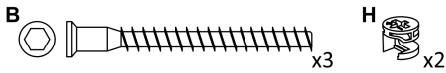
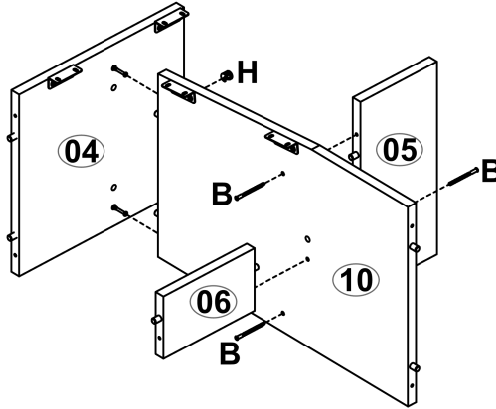
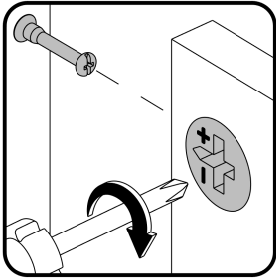
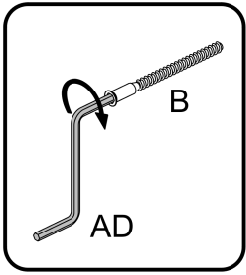

- 10 - \*Fix part 09 to previous assembly with the accessory ( B ).  
\*Fixez la pièce 09 à l'assemblage précédent avec l'accessoire ( B ).  
\*Fijar pieza 09 a ensamble previo con el accesorio ( B ).  
\*Fixe a peça 09 na montagem anterior com o acessório ( B ).

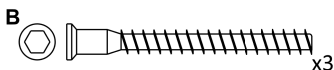
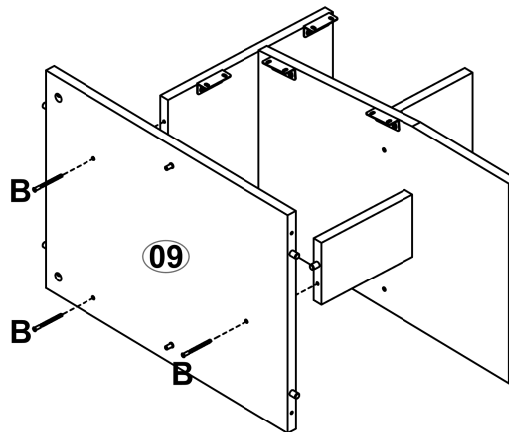
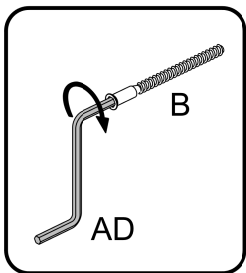



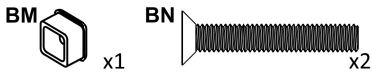
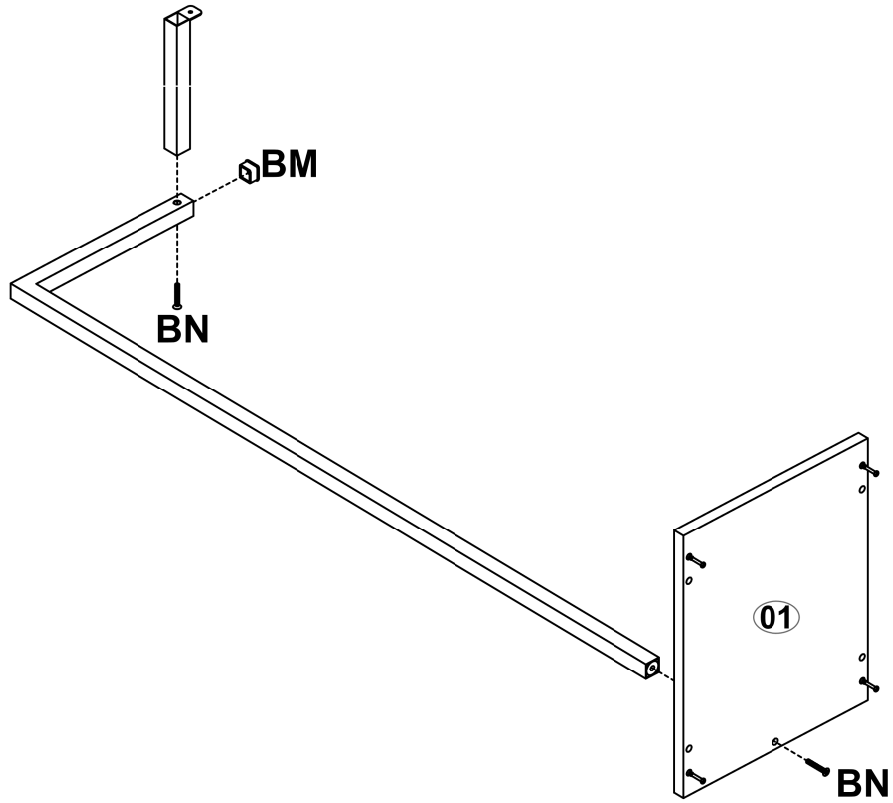

- 12 - \*Fix part 01 to previous assembly with the accessory ( H ) and part 03 with the accessory ( B ).  
 \*Fixez la pièce 01 à l'assemblage précédent avec l'accessoire ( H ) et la pièce 03 avec l'accessoire ( B ).  
 \*Fijar pieza 01 a ensamble previo con el accesorio ( H ) y pieza 03 con el accesorio ( B ).  
 \*Fixe a peça 01 na montagem anterior com o acessório ( H ) e a peça 03 com o acessório ( B ).

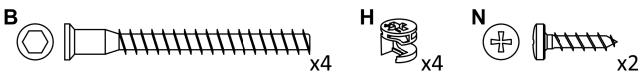
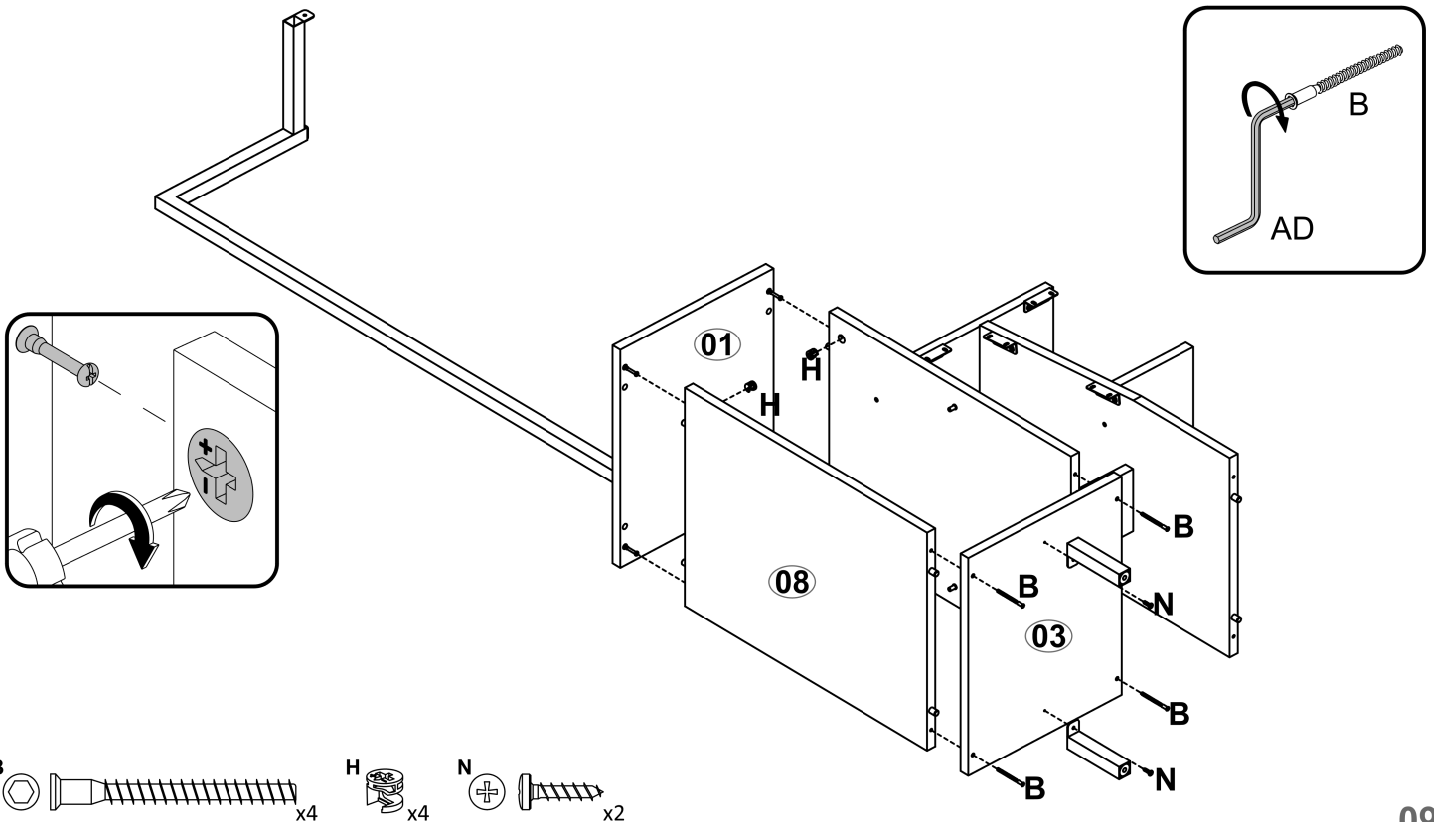

- 13 -** \*Fix part **12** to previous assembly with the accessory ( **J** ) and part **07** with the accessory ( **BN** ).  
 \*Fixez la pièce **12** à l'assemblage précédent avec l'accessoire ( **J** ) et la pièce **07** avec l'accessoire ( **BN** ).  
 \*Fijar pieza **12** a ensamble previo con el accesorio ( **J** ) y pieza **07** con el accesorio ( **BN** ).  
 \*Fixe a peça **12** na montagem anterior com o acessório ( **J** ) e a peça **07** com o acessório ( **BN** ).

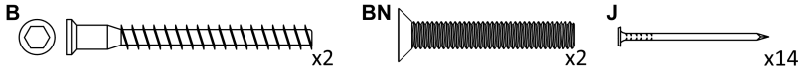
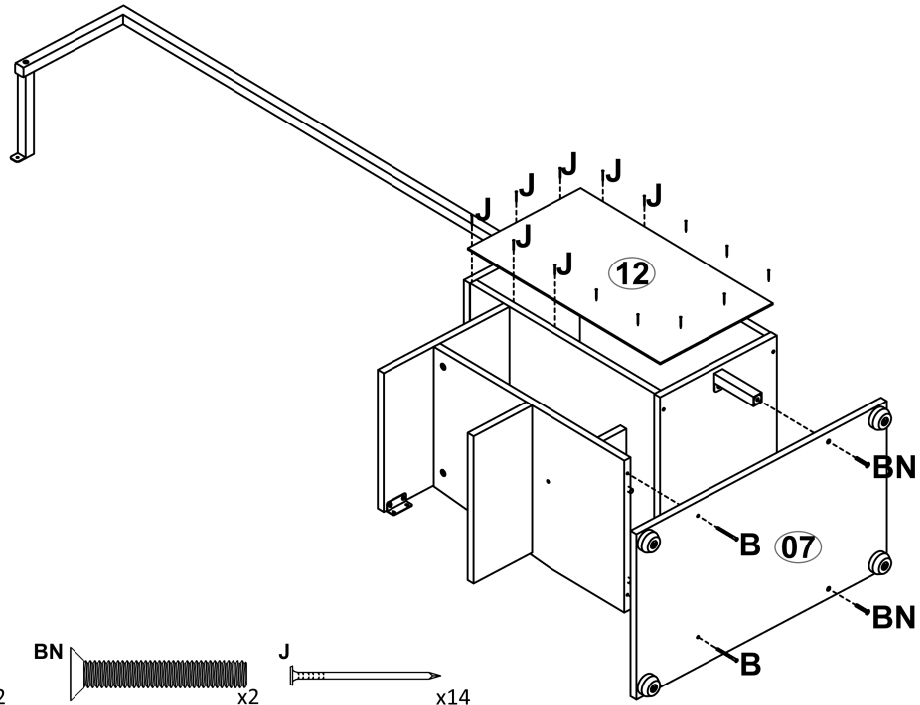
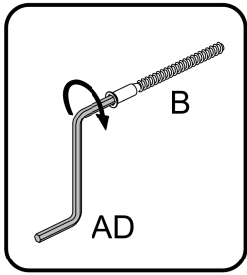

- 14 -** \*Fix part **11** to previous assembly with the accessory ( **N** ).  
 \*Fixez la pièce **11** à l'assemblage précédent avec l'accessoire ( **N** ).  
 \*Fijar pieza **11** a ensamble previo con el accesorio ( **N** ).  
 \*Fixe a peça **11** na montagem anterior com o acessório ( **N** ).

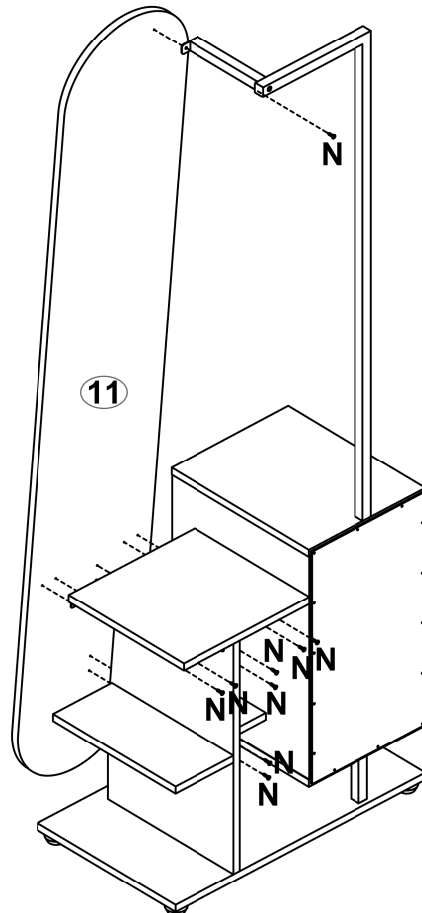

**\*Note:** the missing holes must be made with the screwdriver and the corresponding screw.  
**\*Remarque:** Les trous manquants doivent être faits avec le tournevis et la vis correspondante.  
**\*Nota:** los agujeros faltantes deben hacerse con el destornillador y el tornillo correspondiente.  
**\*Nota:** As furações faltantes devem ser feitas com a chave e o parafuso correspondente.



**\*Note:** Use the stickers and caps to finish.  
**\*Remarque:** Utiliser les autocollants et les capuchons pour terminer la finition.  
**\*Nota:** Utilice los adhesivos y tapas para finalizar el acabado.  
**\*Nota:** Utilize os adesivos e tampas para finalizar o acabamento.