

Instruções de montagem

Cama Mezzo

-Nível de complexidade

1 2 3 4 5



-Somente adultos



3:30h

-Montar de uma só vez

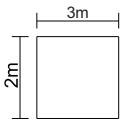
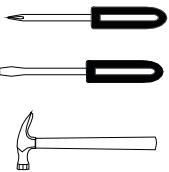

-Superfície de montagem

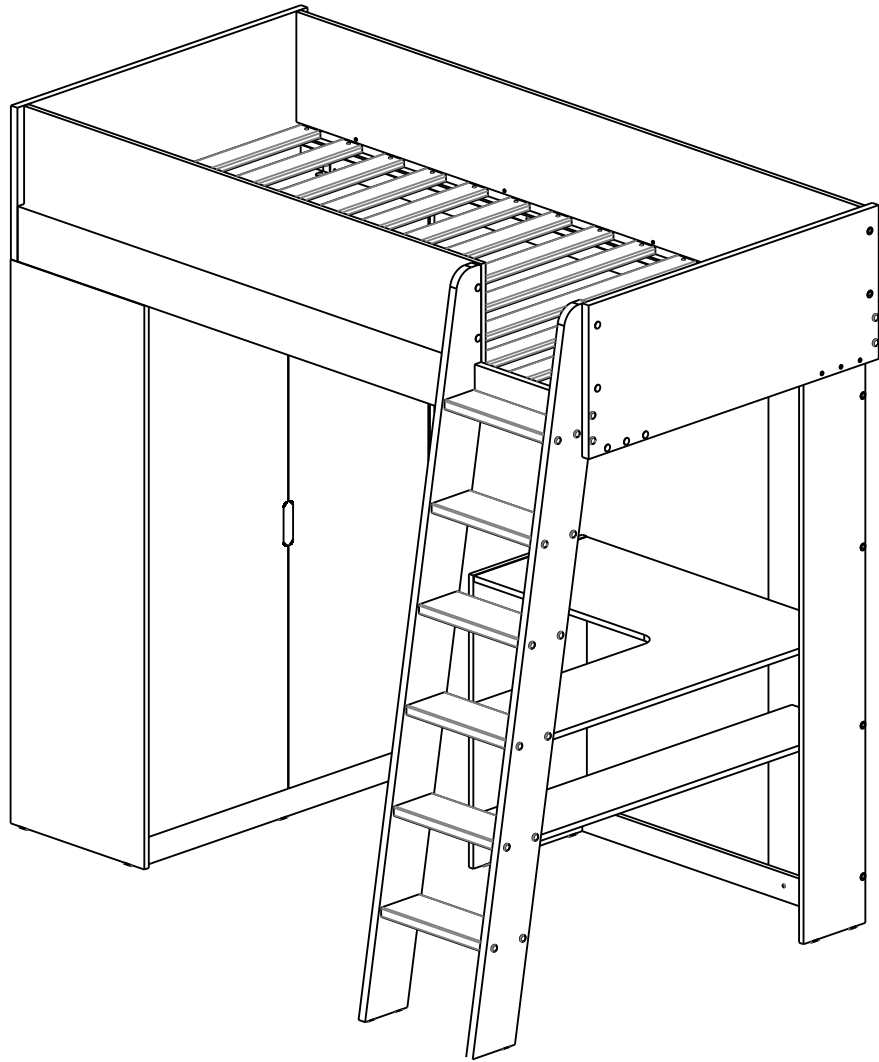

- GUARDAR PARA FUTURAS REFERÊNCIAS.



RECOMENDAÇÕES ANTES DA MONTAGEM

- Siga sempre as instruções do fabricante.

Por favor, verifique o conteúdo listado nas instruções de montagem para garantir que você tenha todos os componentes.

- Sempre monte o produto na sala designada para garantir que ele caiba no espaço designado.

- Sempre monte o produto na ordem correta e não aperte totalmente os parafusos antes de ter tudo montado.

- Se deseja devolver seu pedido o produto deve estar completo e devidamente embalado em sua caixa original.

-IMPORTANTE: GUARDE UMA CÓPIA DO AVISO DE SEGURANÇA E DAS INSTRUÇÕES DE MONTAGEM PARA REFERÊNCIA FUTURA

- SEGURANÇA: O PRODUTO ESTÁ EM CONFORMIDADE COM AS NORMAS DE SEGURANÇA DA UE: NF EN 747-1 + A1: 2015 ET NF EN 747-2 + A1: 2015.

COLCHÃO: O tamanho recomendado do colchão para esta cama é 90 x 190 cm.

De acordo com as normas de segurança europeias NF EN 747-1 + A1: 2015, recomendamos o uso de um colchão

espessura menor ou igual a 13 cm para preservar uma altura de barreira de 16 cm acima do colchão.

INSTRUÇÕES DE USO:

AVISO: o beliche superior e qualquer cama elevada não são adequados para crianças menores de 6 anos de idade devido ao risco de ferimentos relacionados às quedas.

AVISO: Se os beliches e as camas elevadas não forem usados corretamente, eles podem representar um sério risco de lesão por estrangulamento. Nunca prenda ou pendure itens em partes da cama de beliche que não foram projetadas para uso com a referida cama. Esses fatores incluem, mas não estão limitados a, cordas, cordas, cordas, cordas, ganchos, cintos e bolsas.

AVISO: As crianças podem ficar presas entre a cama e a parede, entre um telhado inclinado, teto, móveis adjacentes (por exemplo, armários) ou outros. Para evitar ferimentos graves, a distância entre o a barreira de segurança superior e os elementos circundantes não devem exceder 75 mm ou ser maiores que 230 mm.

AVISO: Não use o beliche ou cama alta se alguma parte da estrutura estiver faltando ou quebrada. Verifique regularmente se todos os fixadores e parafusos estão devidamente apertados. Ventile a sala regularmente para manter um nível de umidade baixo e evitar o crescimento de mofo.

Componentes usados





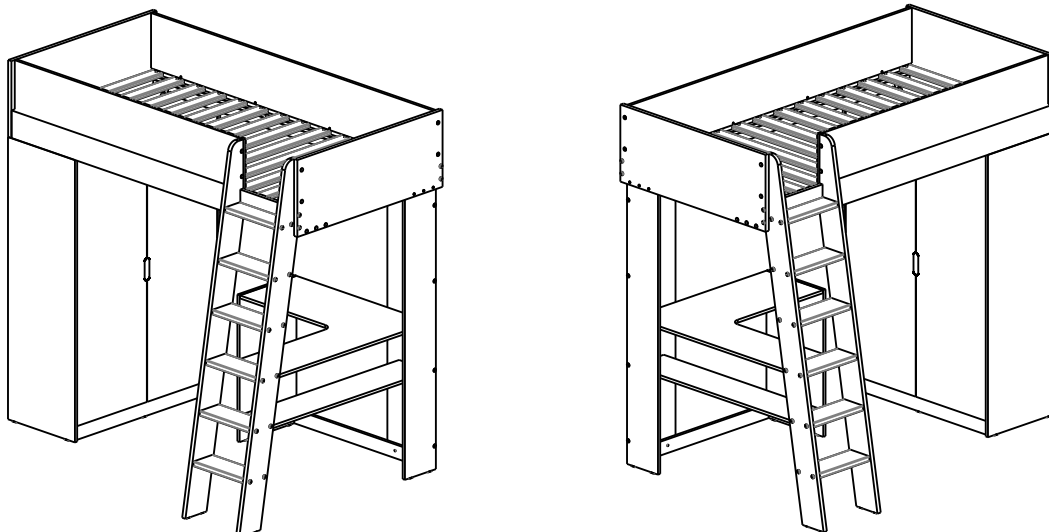

DESCRIÇÃO DE COMPONENTES

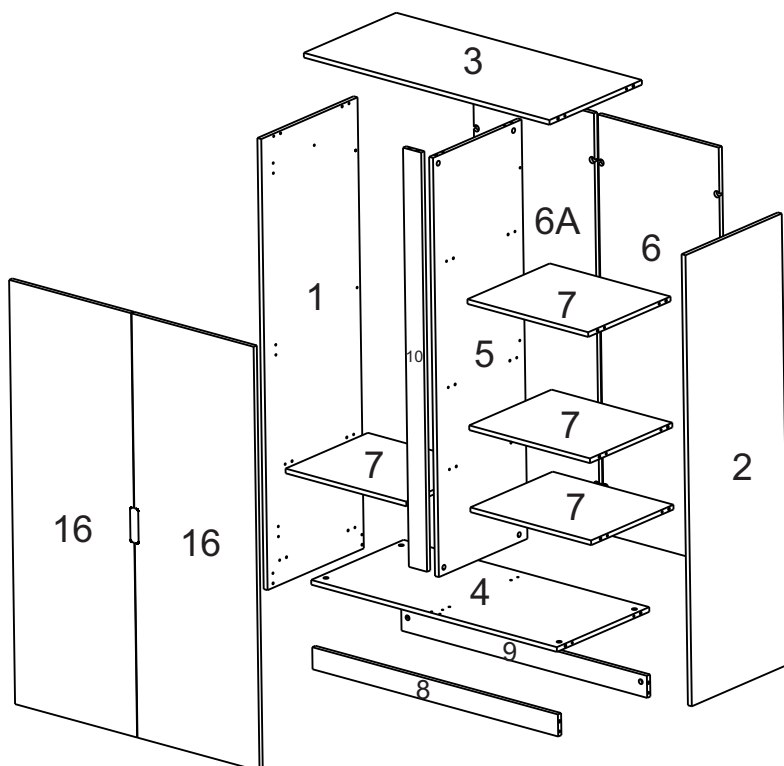
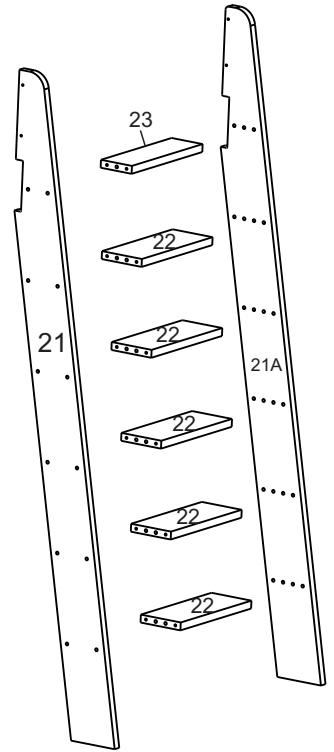
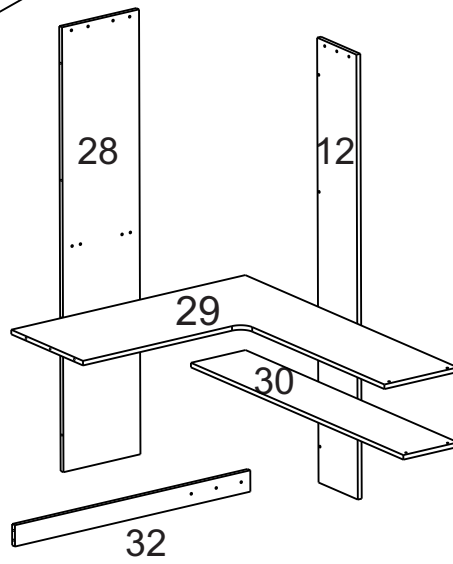
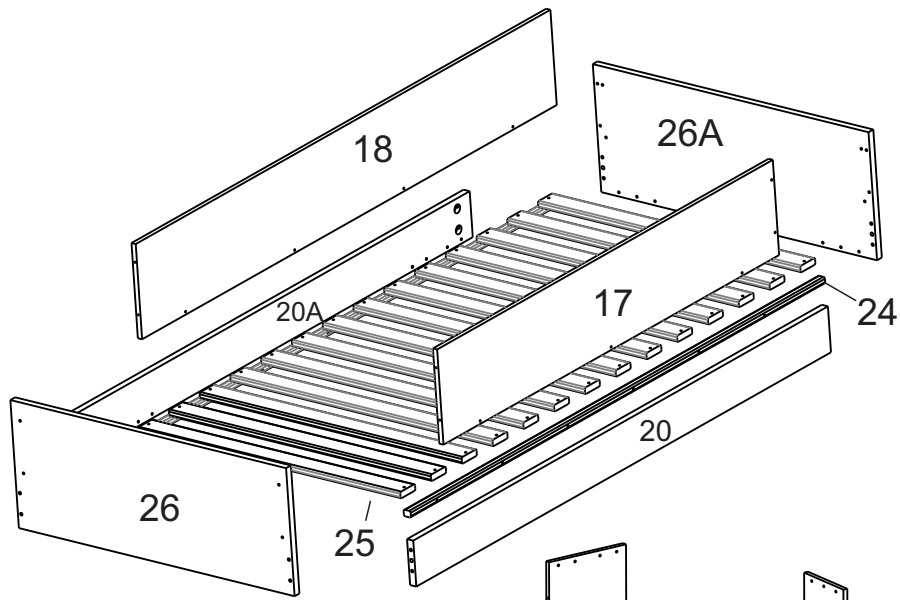

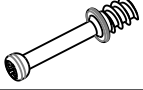

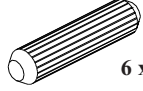

- N° da peça	- Dimensão da peça	- Quantidade	- Caixa
1	1430x450x15	1	1/5
2	1430x450x15	1	1/5
3	946x432x15	1	2/5
4	946x432x15	1	2/5
5	1329x415x15	1	3/5
6	1329x465x15	2	3/5
7	465x375x15	4	2/5
8	946x70x15	1	4/5
9	946x70x15	1	4/5
10	1329x70x15	1	1/5
12	1460x208x15	1	1/5
16	1345x470x15	2	3/5
17	1538x290x15	1	4/5
18	1900x290x15	1	4/5
20	1900x140x22	1	4/5
20A	1900x140x22	1	4/5
21	1860x140x22	1	4/5
21A	1860x140x22	1	4/5
22	340x130x25	5	5/5
23	340x100x25	1	5/5
24	1898x25x20	2	4/5
25	928x68x20	14	4/5
26	976x390x22	2	5/5
26A	976x390x22	2	5/5
28	1460x296x15	1	1/5
29	1125x900x15	1	1/5
30	1125x210x15	1	1/5
31	744x382x15	1	1/5
32	905x70x15	1	1/5

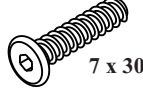



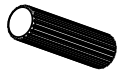

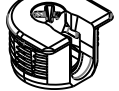
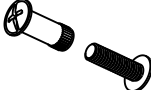

Possibilidade de montagem

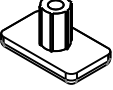
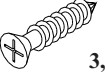

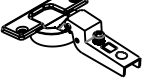
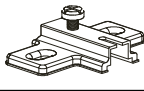

A		36
B		36
C		6
D		36
E		3
F		8
G		8
H		1
I		2

J		6
K		24
L		13
M		22
N		12
O		4
P		3
Q		8
R		7

S		16
T		32
U		29
V		2
W		19
X		2
Y		6
Z		6
A1		65
A2		53
A3		1

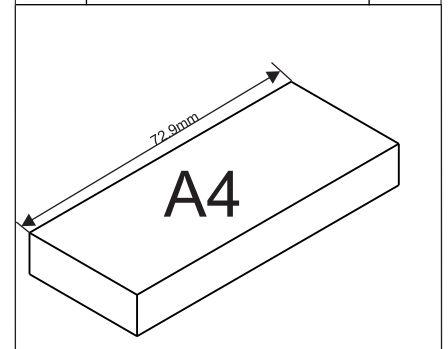
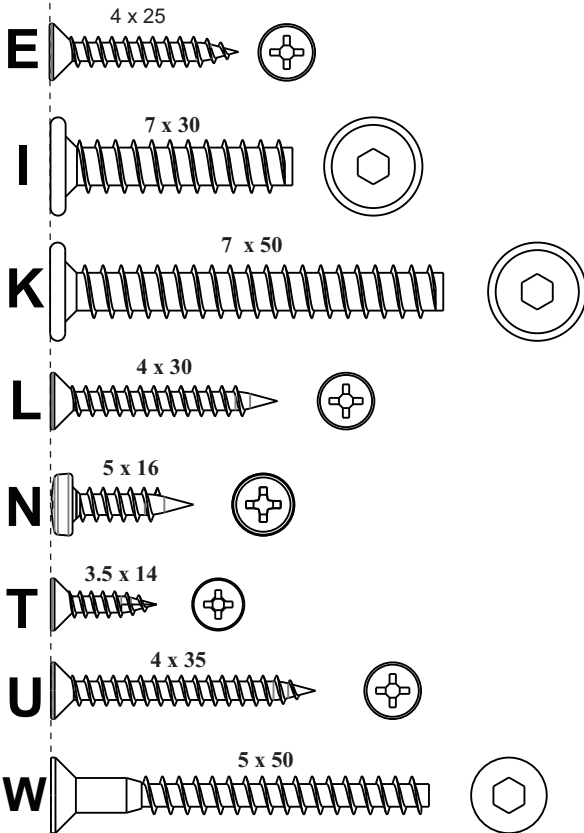
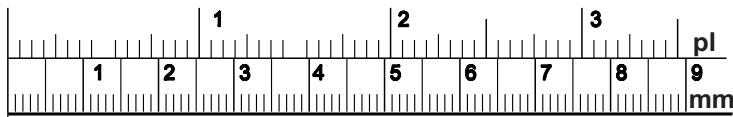

1

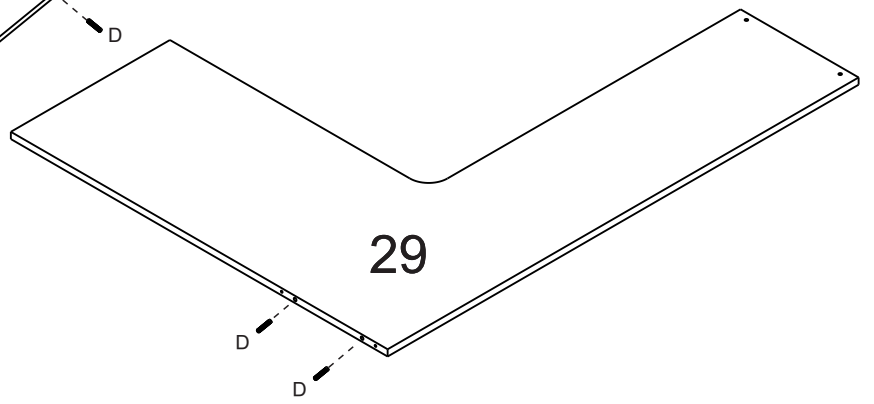
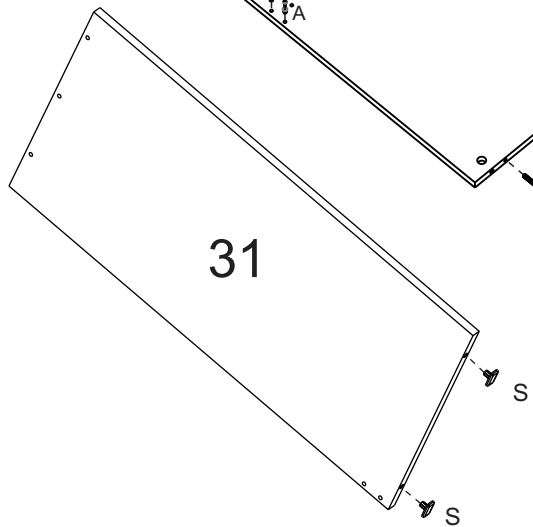
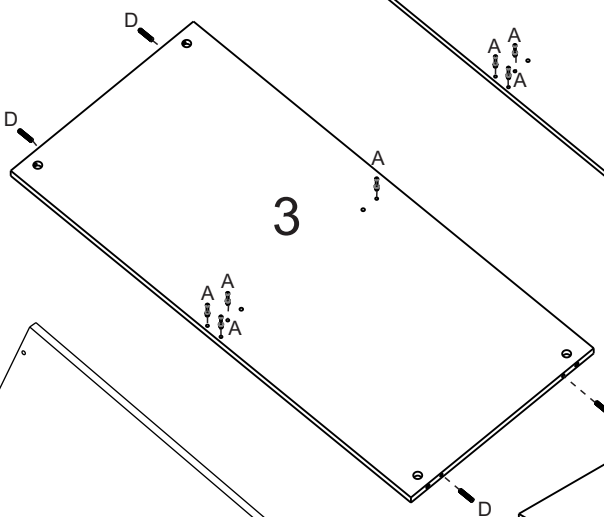
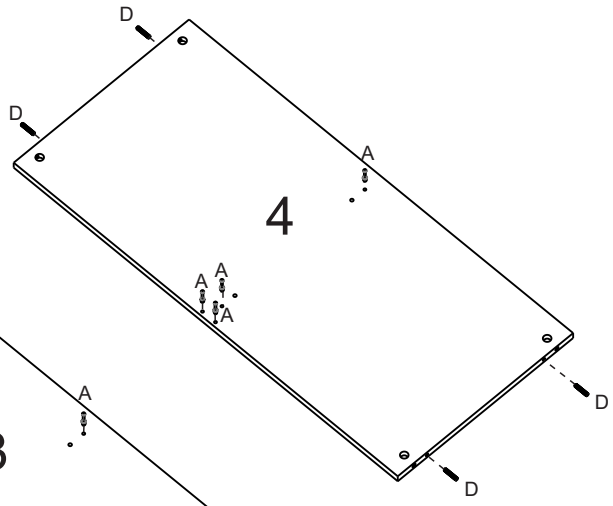
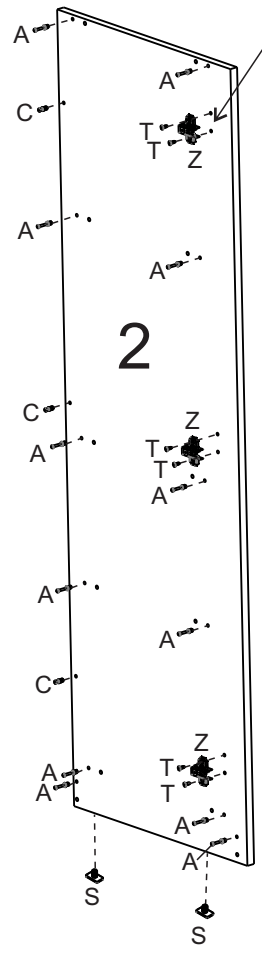
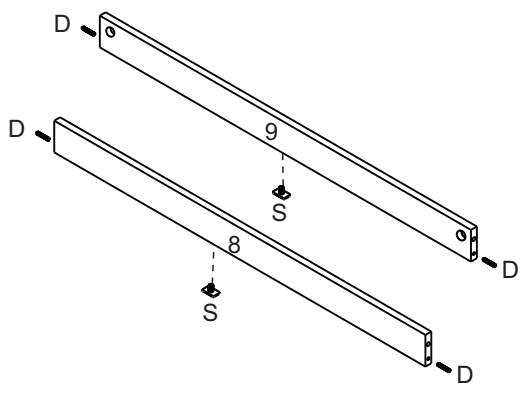
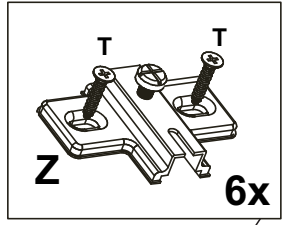
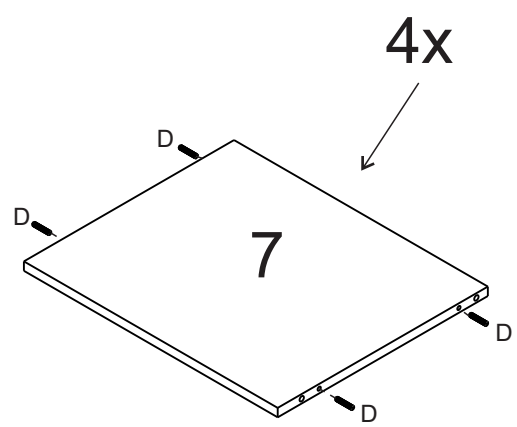
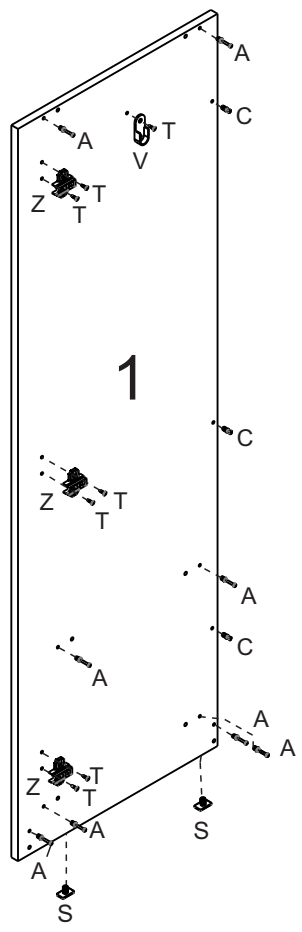
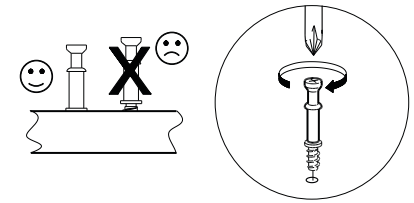
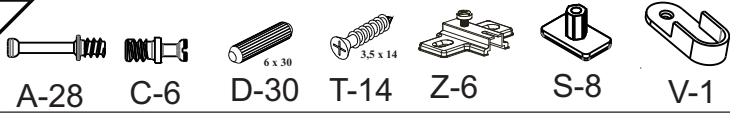

2

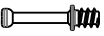

A-8



D-4



T-14



Q-12

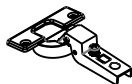

Y-6



V-1



P-3

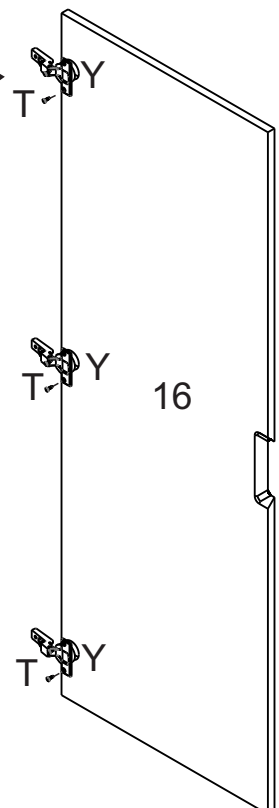
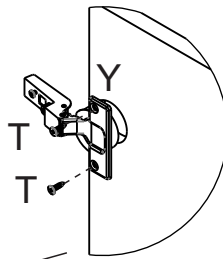
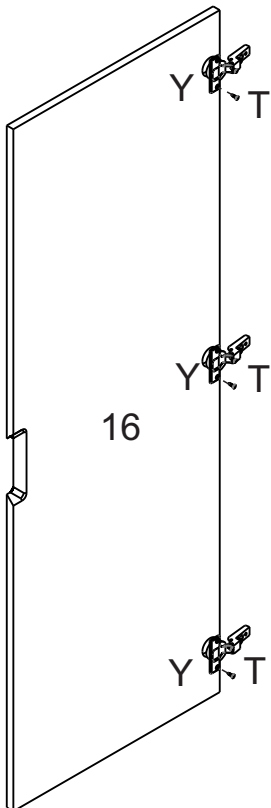
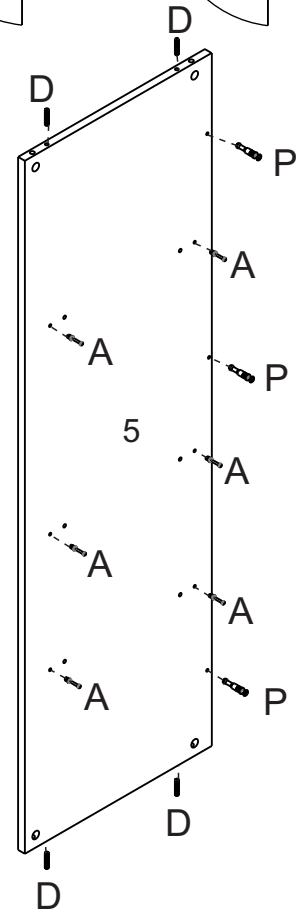
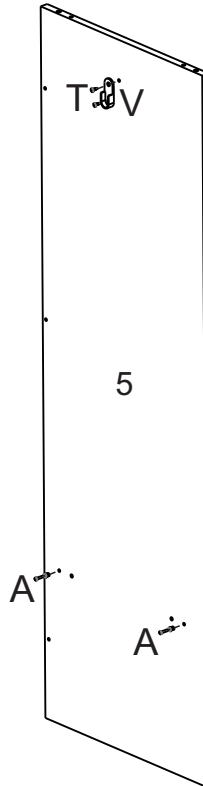
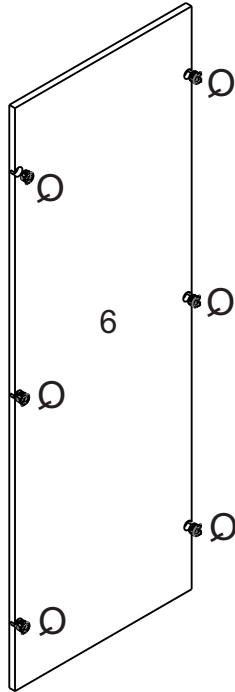
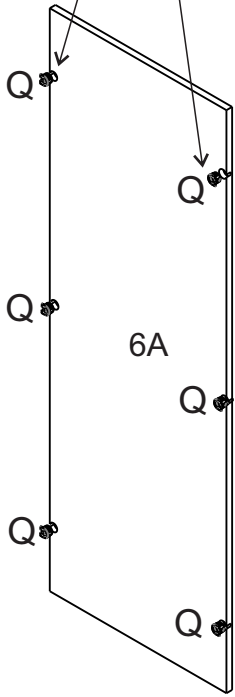
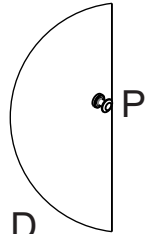
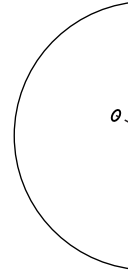
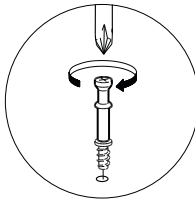
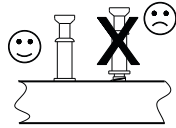
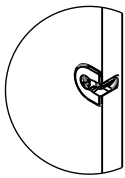
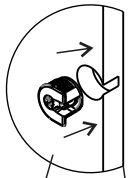

01

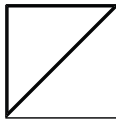

B-32

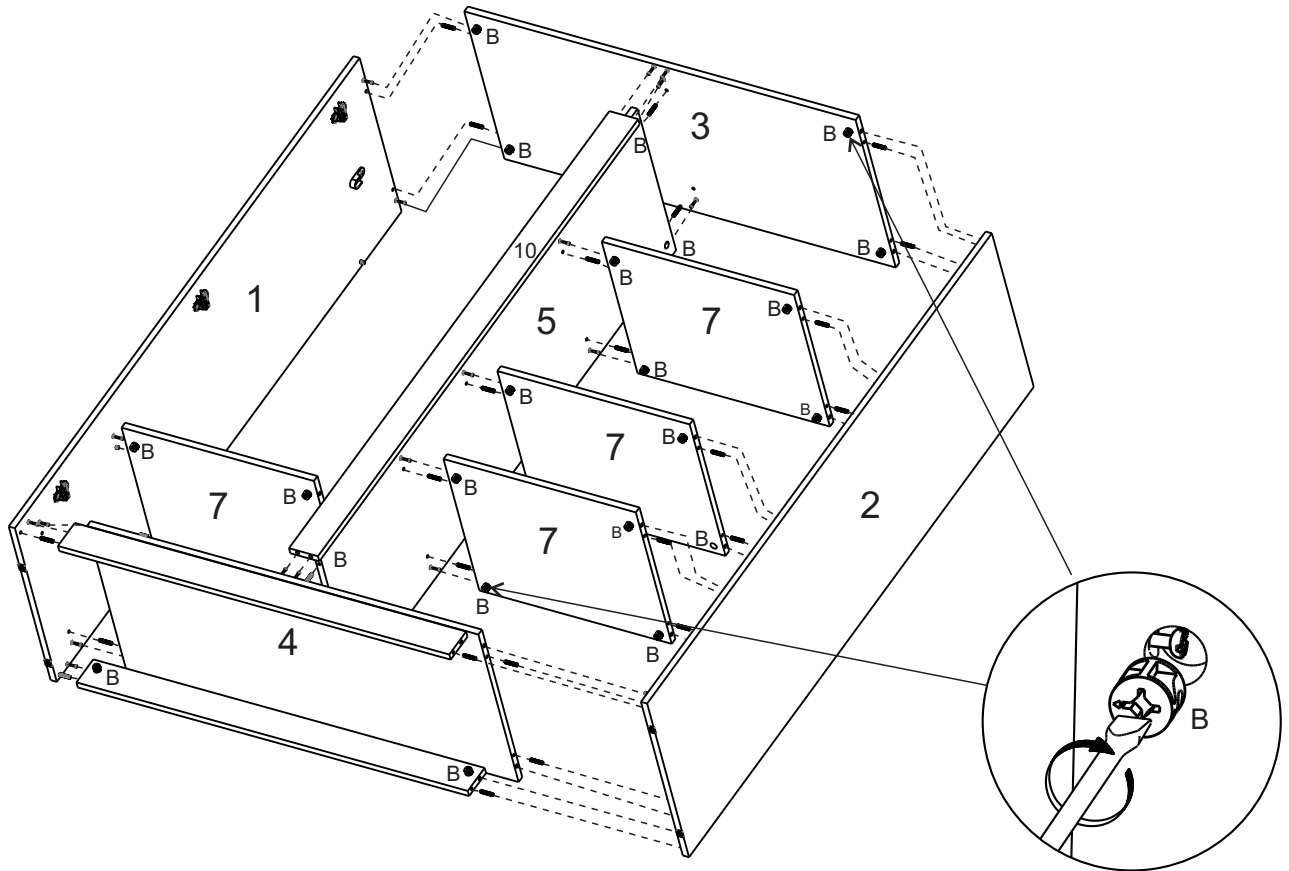

02

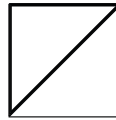

B-4



X-2



T-4

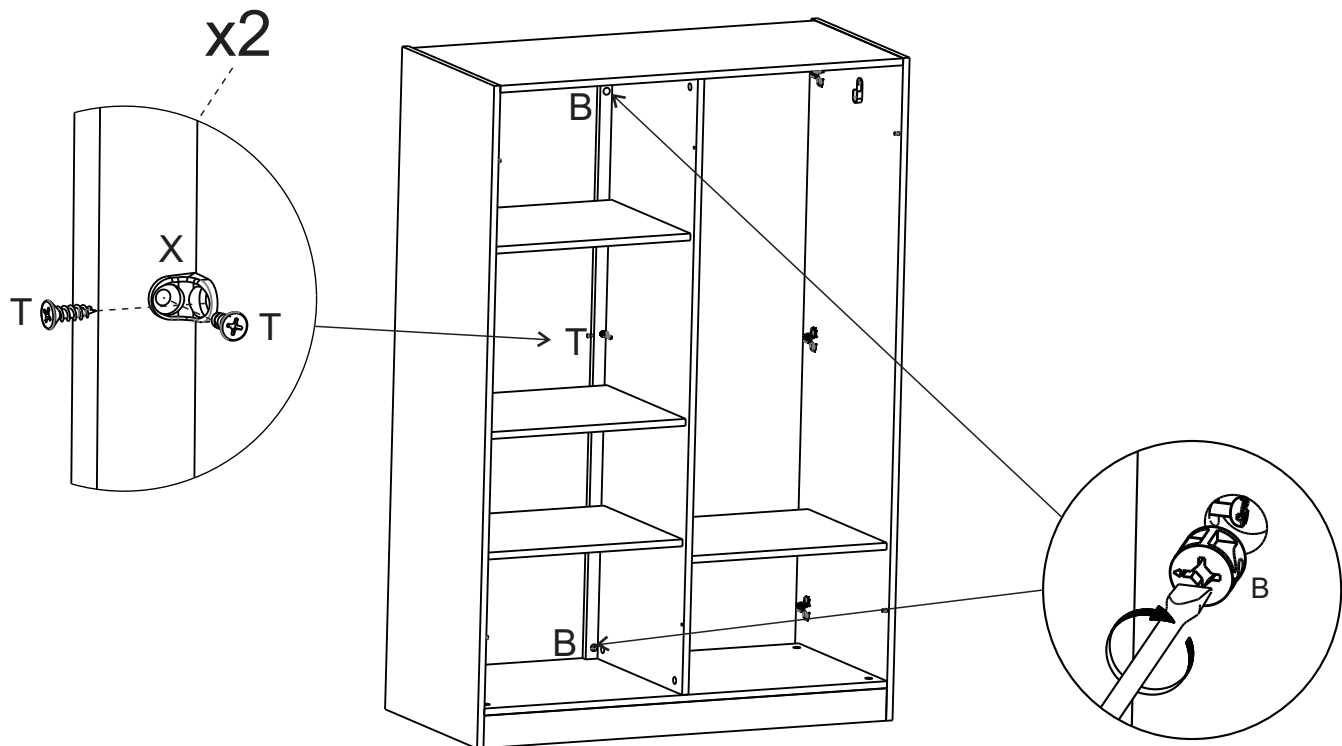

03

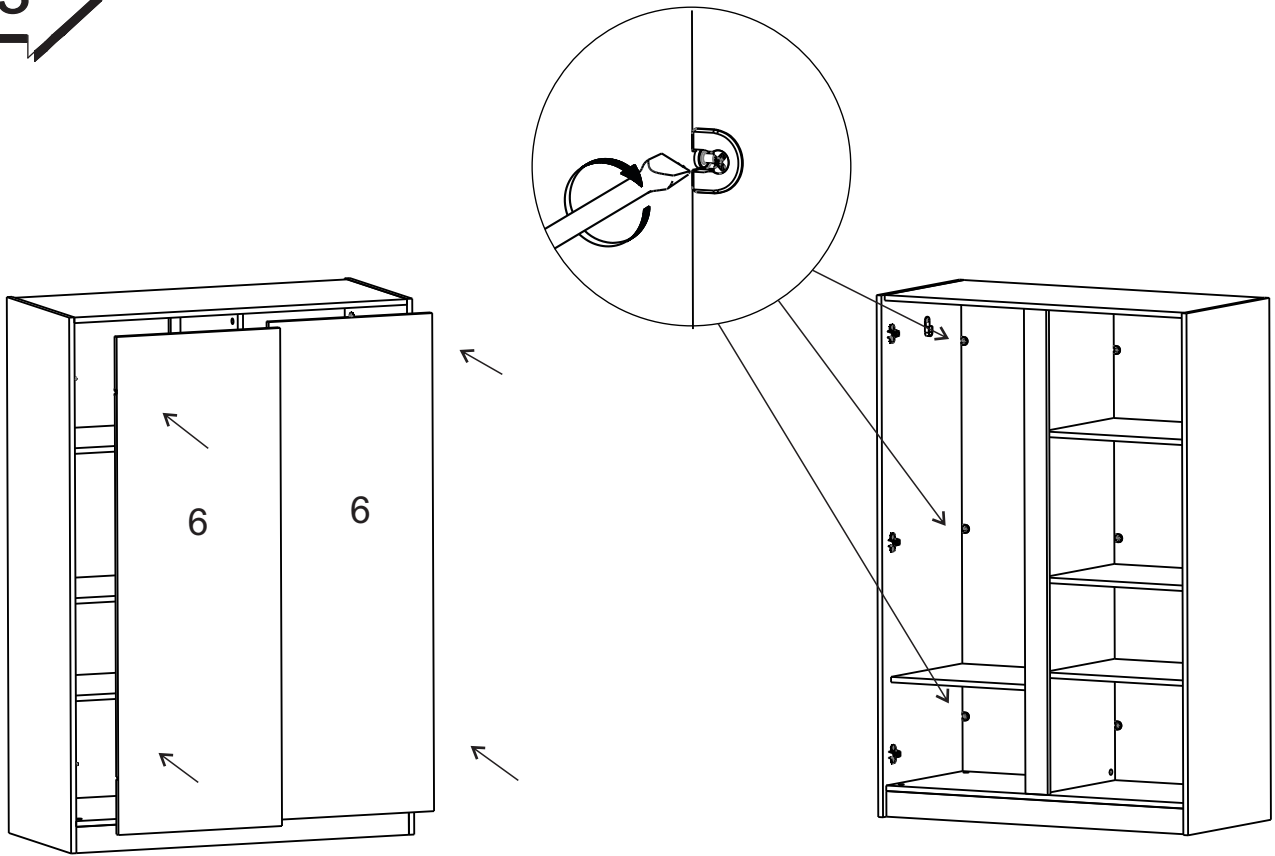

04

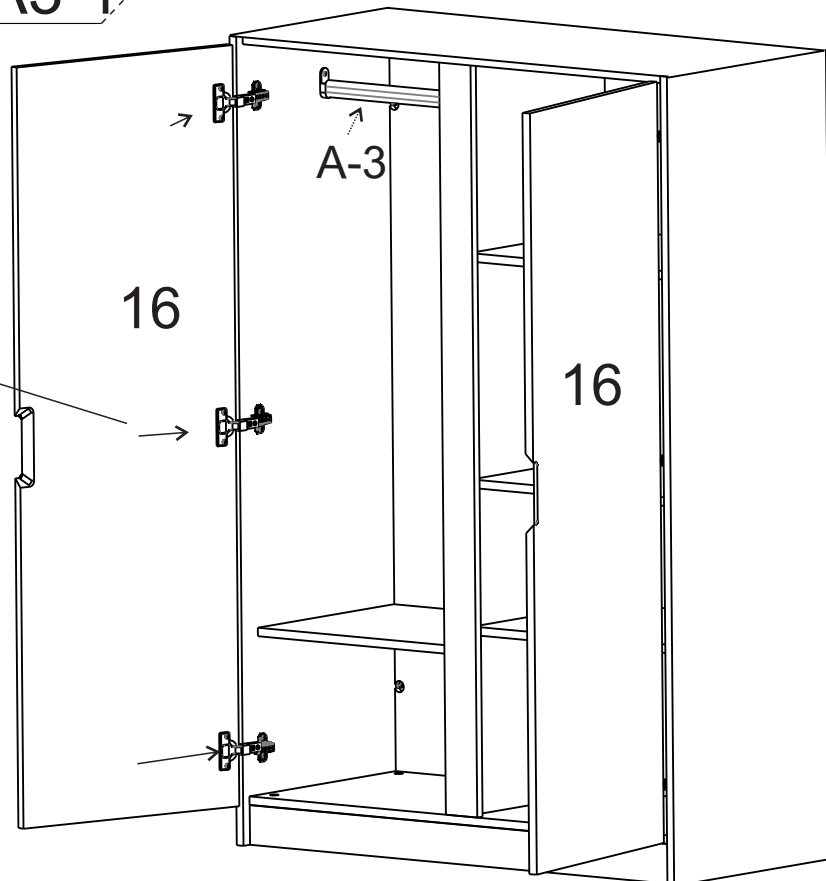
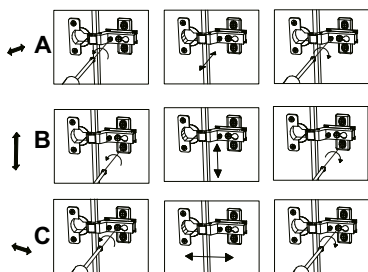
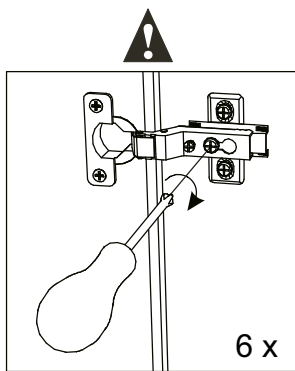

05

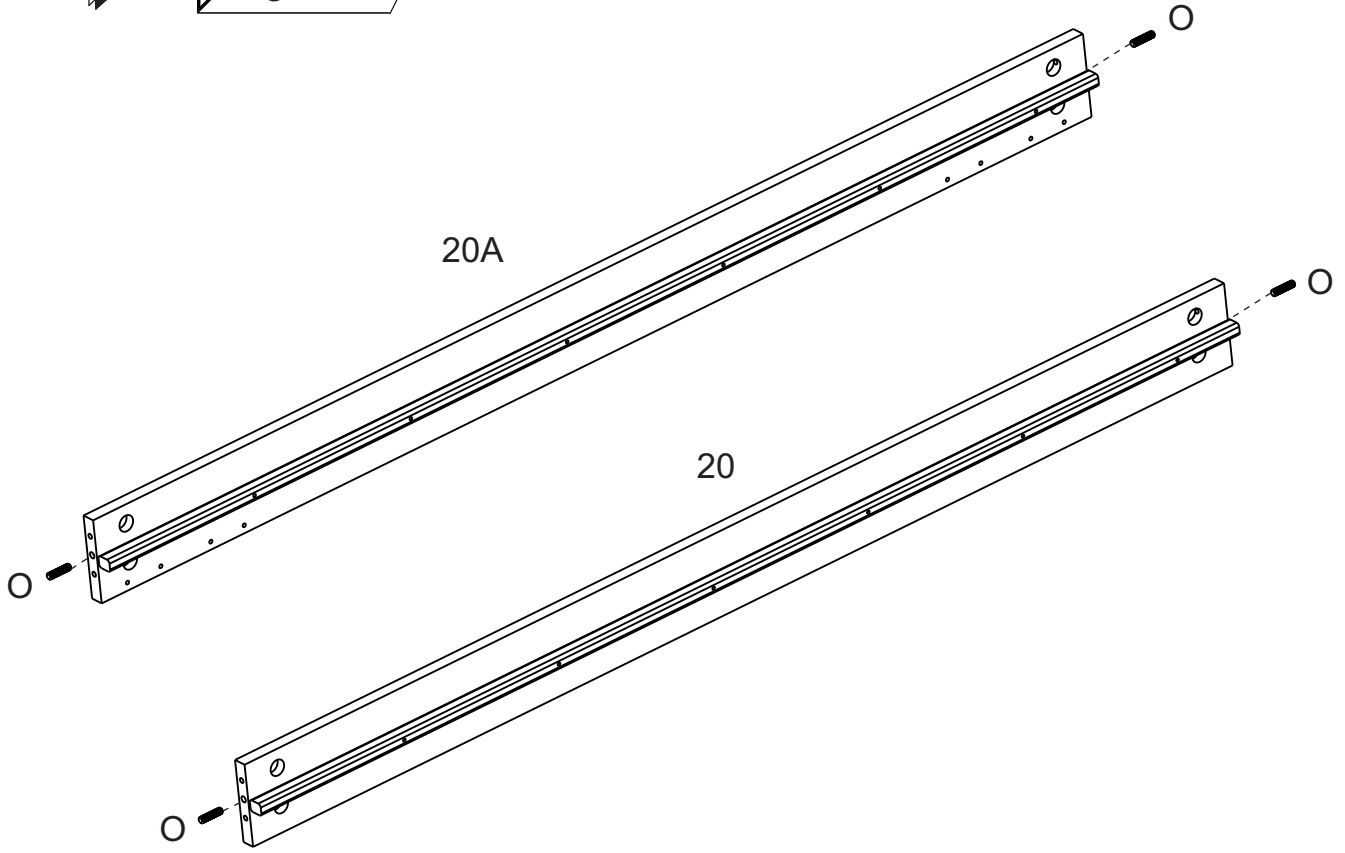
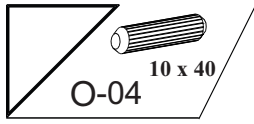

06

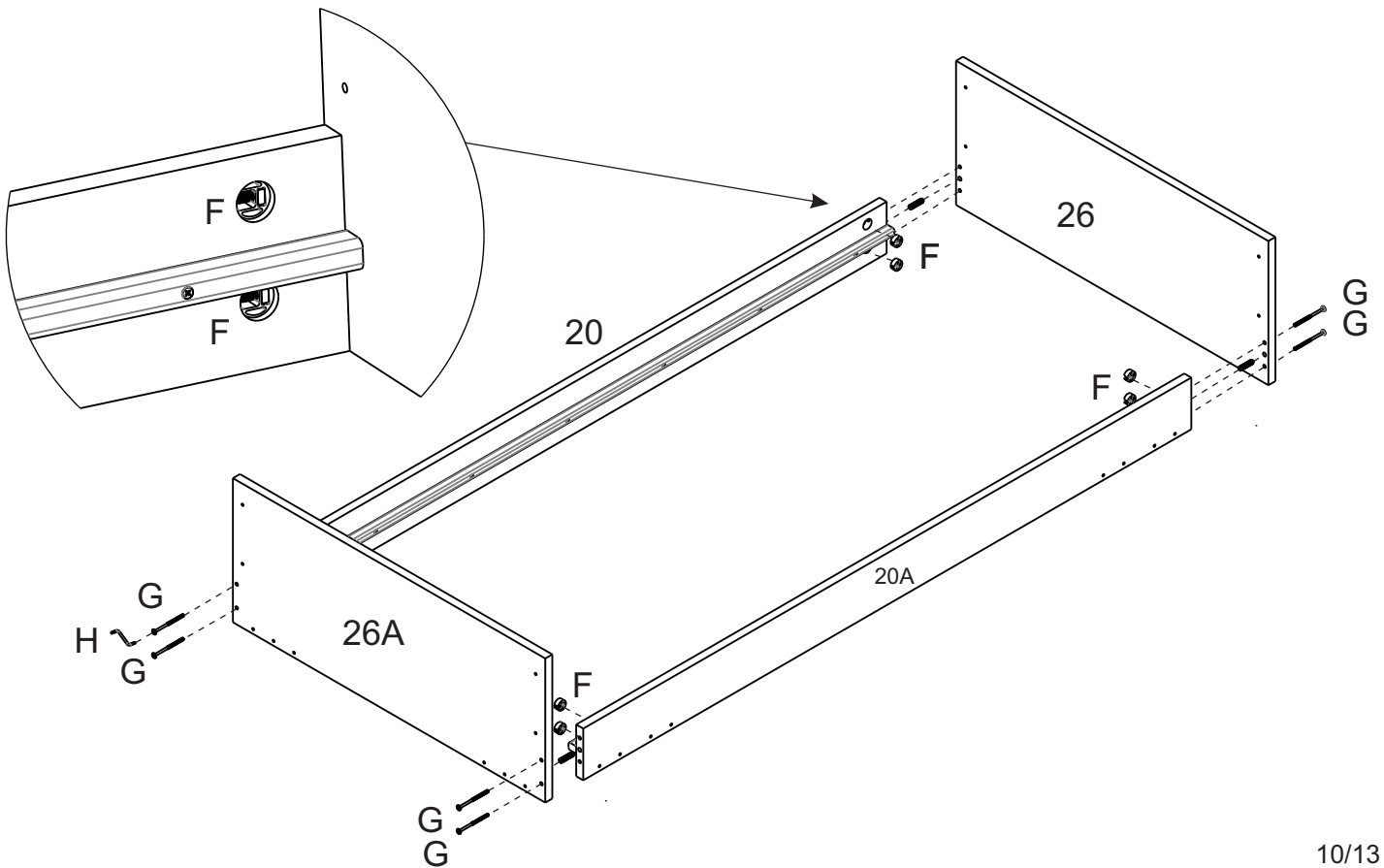

7

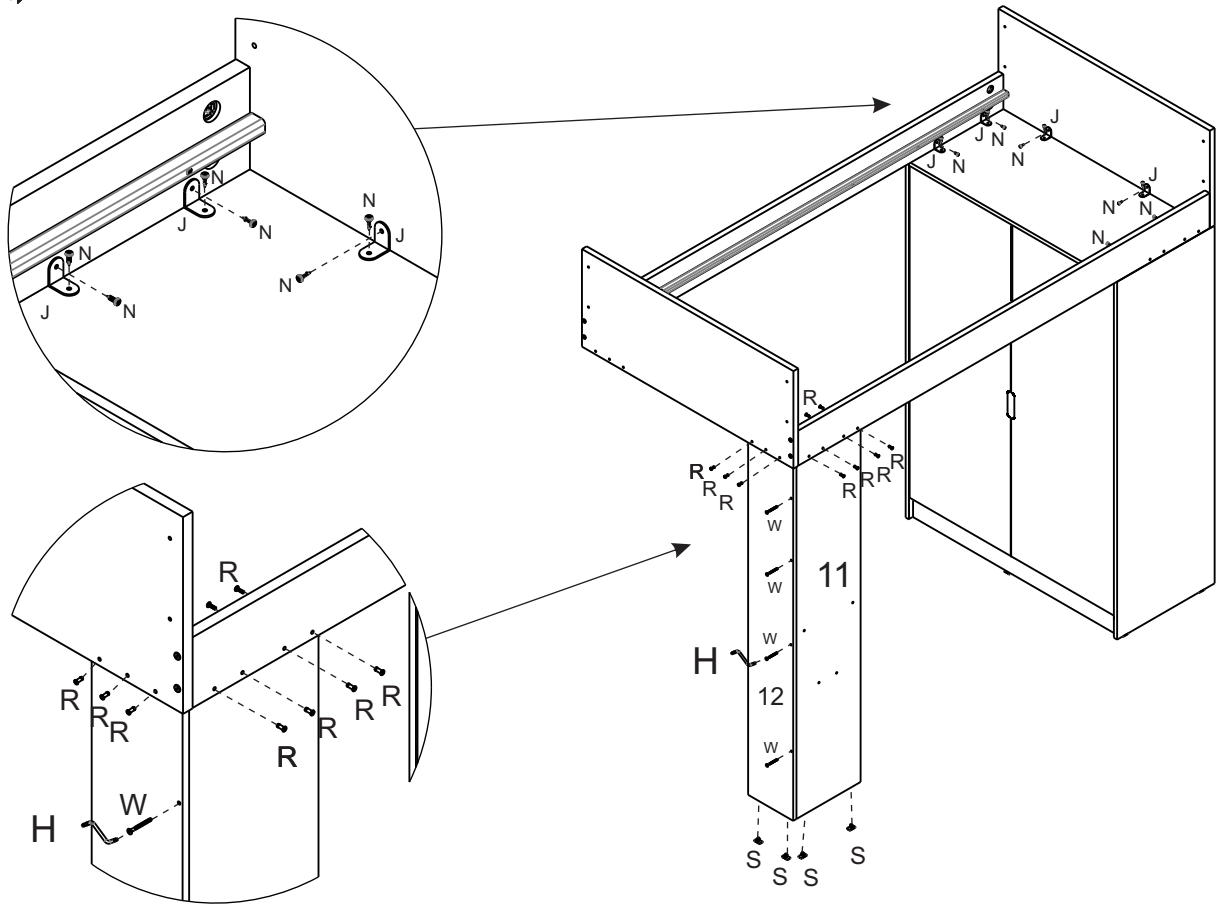
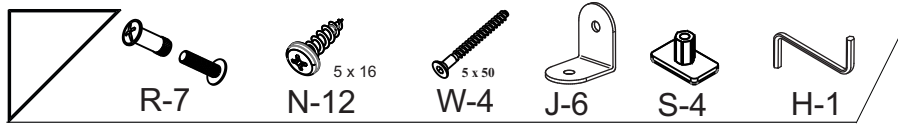

8

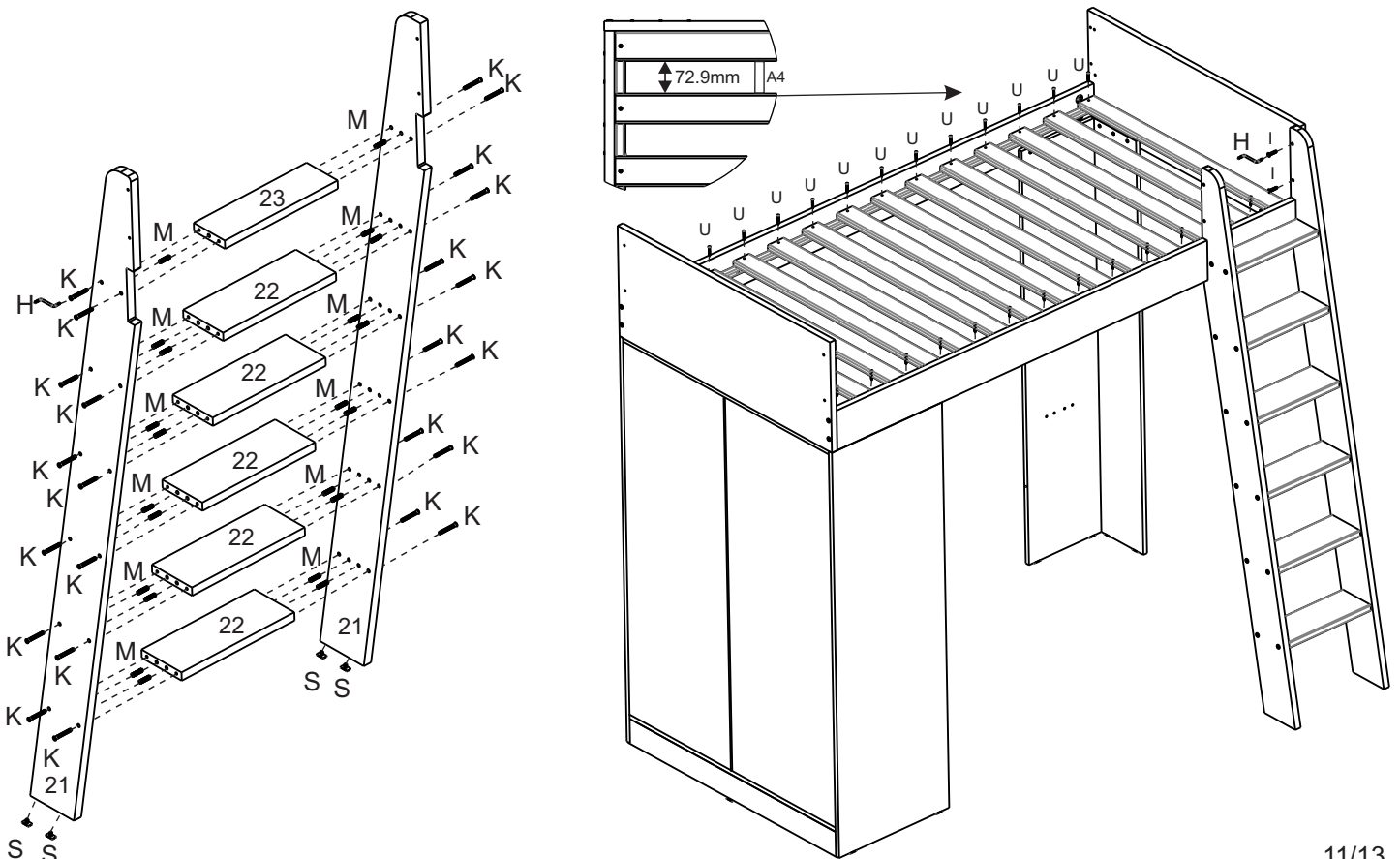
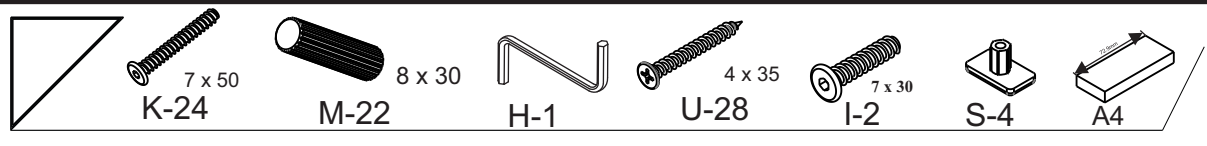

09

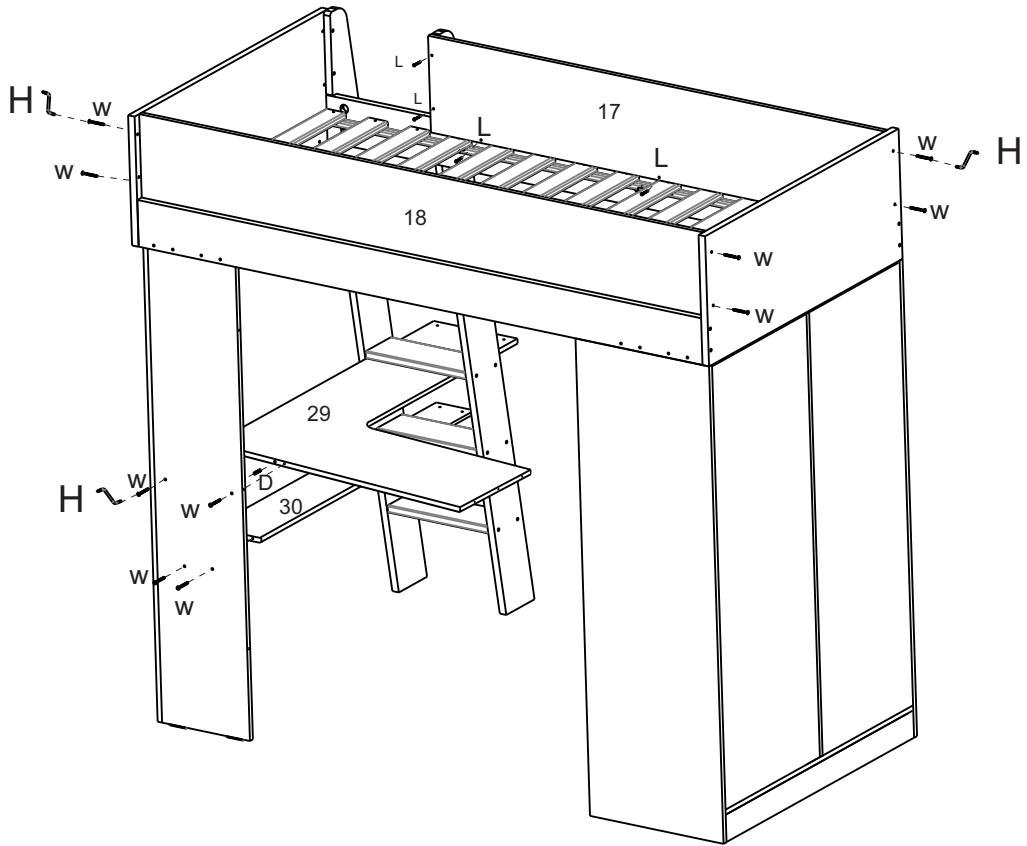
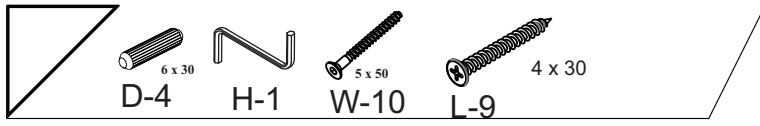

10

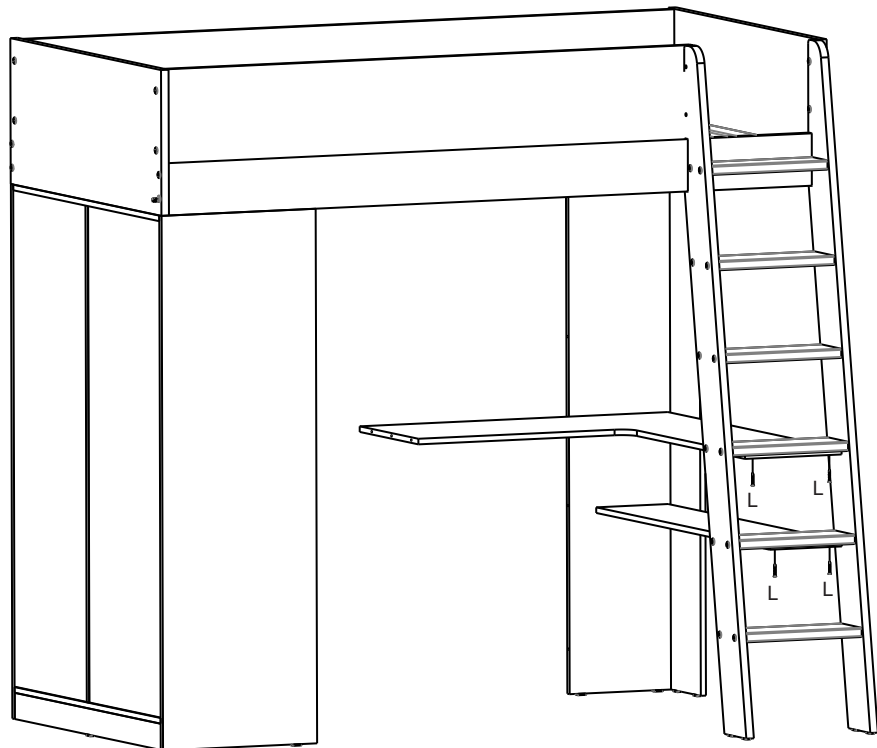
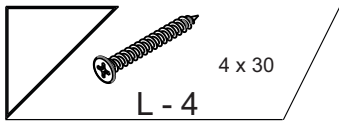

11

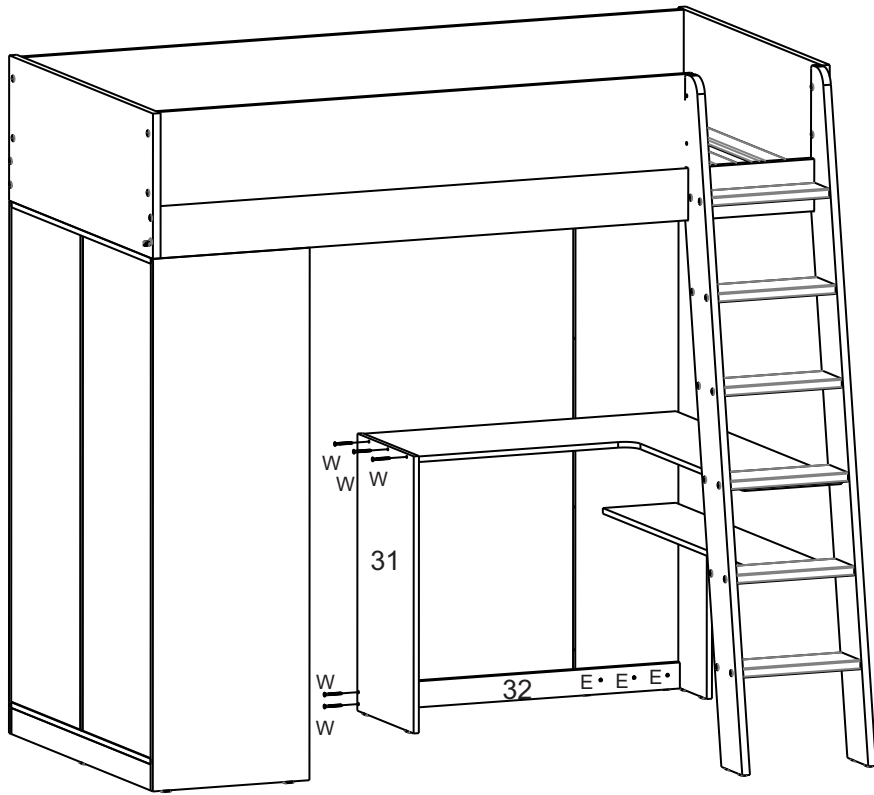
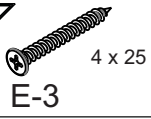

12

