

ASSEMBLY INSTRUCTIONS MANUAL DE MONTAGEM / INSTRUCCIONES DE ARMADO

STAR PLUS HIGH BED - TABLE
CAMA ALTA STAR PLUS - MESA
CAMA ALTA STAR PLUS - MESA

Reference
Referência
Referencia

230197

Revised
Revisão
Revisión

00



ENGLISH
PORTUGUÊS
ESPAÑOL

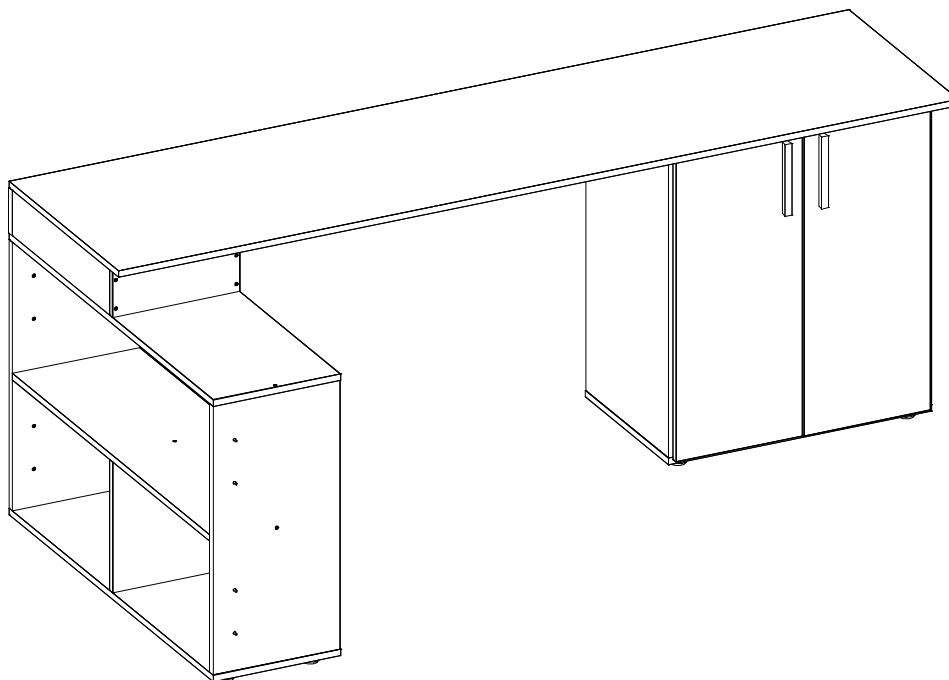

Este produto pode ser montado para a sua esquerda ou direita.
This product can be assembled to left or right.
Este producto se puede armar a la izquierda o derecha.



MAXIMUM RECOMMENDED WEIGHT
BEING THIS EVENLY DISTRIBUTED.

PESO MÁXIMO RECOMENDADO SENDO
ESTE DISTRIBUÍDO UNIFORMEMENTE.

PESO MÁXIMO RECOMENDADO SIENDO
ESTE UNIFORMEMENTE DISTRIBUIDO.

	LB	KG
D	11	5
F	22	10
H	44	20

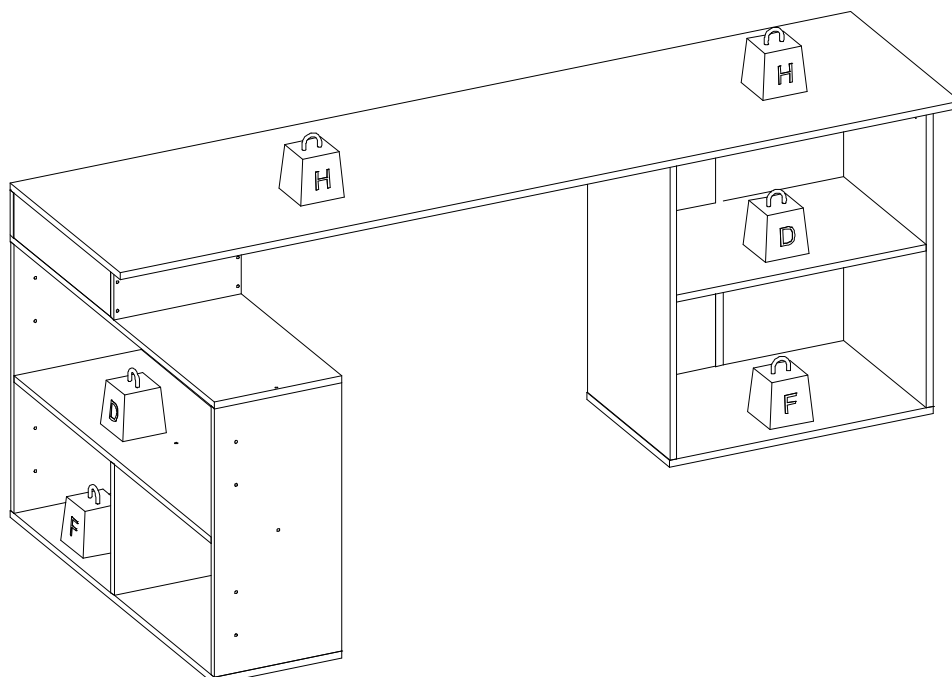

Nº	Measures_Inches	Medidas_cm	Qty./Qtd.
21	75 3/8 x 19 5/8 x 5/8	191.3 x 50.0 x 1.5	1
22	51 3/4 x 4 x 5/8	131.4 x 10.1 x 1.5	1
23	11 3/8 x 4 x 5/8	29.0 x 10.1 x 1.5	1
24	17 3/8 x 4 x 5/8	44.2 x 10.1 x 1.5	2
25	36 5/8 x 11 3/8 x 5/8	93.0 x 29.0 x 1.5	1
26	35 3/8 x 11 3/8 x 5/8	89.9 x 29.0 x 1.5	1
27	36 5/8 x 11 3/8 x 5/8	93.0 x 29.0 x 1.5	1
28	23 5/8 x 11 3/8 x 5/8	59.9 x 29.0 x 1.5	2
29	11 1/2 x 11 3/8 x 5/8	29.2 x 29.0 x 1.5	1
30	22 3/8 x 2 3/4 x 5/8	56.9 x 7.0 x 1.5	1
31	2 3/4 x 22 3/8 x 5/8	7.0 x 56.9 x 1.5	1
32	22 3/8 x 14 7/8 x 5/8	56.9 x 37.7 x 1.5	1
33	23 5/8 x 14 7/8 x 5/8	60.0 x 37.7 x 1.5	1
34	28 1/8 x 14 7/8 x 5/8	71.5 x 37.7 x 1.5	1
35	28 1/8 x 14 7/8 x 5/8	71.5 x 37.7 x 1.5	1
36	28 x 11 3/8 x 5/8	71.0 x 28.8 x 1.5	1
37	28 x 11 3/8 x 5/8	71.0 x 28.8 x 1.5	1
38	28 3/8 x 11 1/2 x 1/8	72.0 x 29.1 x 0.3	2
S17	x x	x x	2

PARTS IDENTIFICATION
IDENTIFICAÇÃO DAS PEÇAS / IDENTIFICACIÓN DE LAS PIEZAS

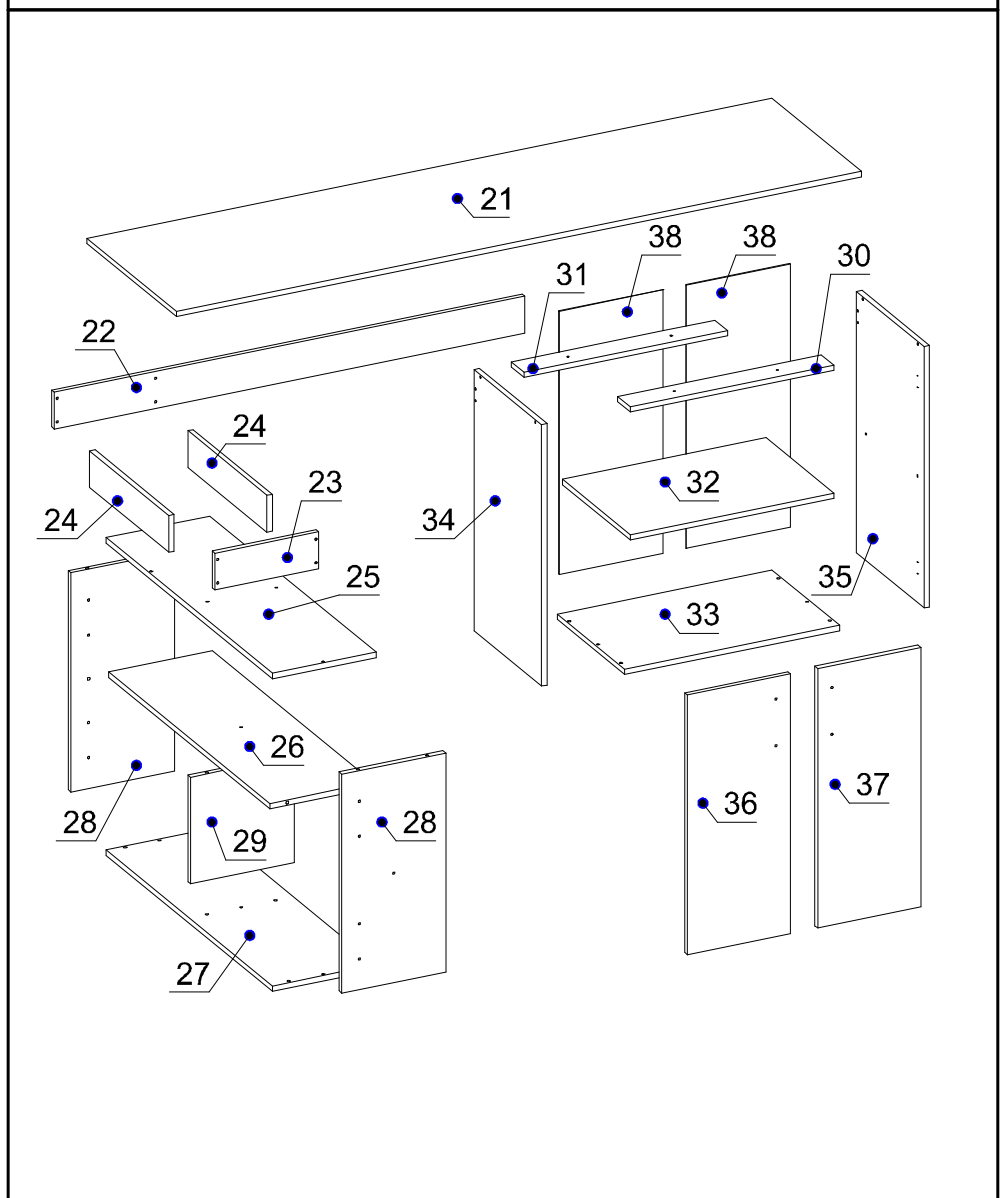

YOU WILL NEED / VOCÊ VAI PRECISAR DE / USTED NECESITARÁ

Tools not supplied / Ferramentas não fornecidas / Herramientas no incluidas

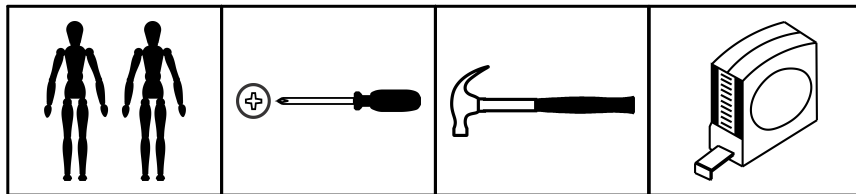

2 People / 2 Pessoas / 2 Personas
 Screwdriver Phillips / Chave Phillips / Destornillador cruz
 Hammer / Martelo / Martillo
 Measuring tape / Trena / Cinta de medición











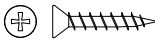
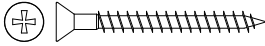

The separation of the accessories before you start the assembly will facilitate the same. In case of doubt on the size of the screws and bolts, use the ruler to bottom of page 3.

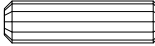
A separação dos acessórios antes de iniciar a montagem facilitará a mesma. Em caso de dúvida no tamanho dos parafusos e cavilhas, utilize a régua ao final da página 3.

La separación de los accesorios antes de comenzar el armado facilitará el mismo. En caso de duda sobre el tamaño de los tornillos y taquetes, utilice la regla al pie de página 3.

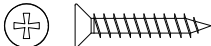
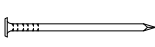
IDENTIFICATION OF ACCESSORIES IDENTIFICAÇÃO DOS ACESSÓRIOS/ IDENTIFICACIÓN DE ACCESORIOS

A4		Metalic bracket / Cantoneira de metal / Suporte de metal	22x22 mm	6
A6		"H" profile / Perfil "H" / Perfil "H"	-	1
A8		Flat head screw / Parafuso chato / Tornillo de cabeza plana	3,5x20 mm	9
D		Flat head screw / Parafuso chato / Tornillo de cabeza plana	4,0x40 mm	28
D5		Hinge shim / Calço dobradiça / Bisagra de calce	-	4
E		Wooden dowel / Cavilha / Taquete	8x30 mm	20
F6		Metal hinge curve / Dobradiça curva / Esquina de bisagra metálica	26 mm	4
H8		Shelf bracket / Suporte de prateleira / Suporte de repisa	6x8 mm	4
L4		Plastic foot / Sapata / Pie plástico	38x17 mm	9
M		Bore patch adhesive / Tapa furo adesivo / Tapones adhesivo	-	20
M1		Flat head screw / Parafuso chato / Tornillo de cabeza plana	3,5x25 mm	18
N		Nail / Pregro / Clavo	10x10	28
S		Pan head screw / Parafuso panela / Tornillo de pan	3,5x14 mm	28
S17		Handle / Puxador F14 / Tirador	160 mm	2



PRE-ASSEMBLE
PRÉ-MONTAGEM / PRE ARMADO

01

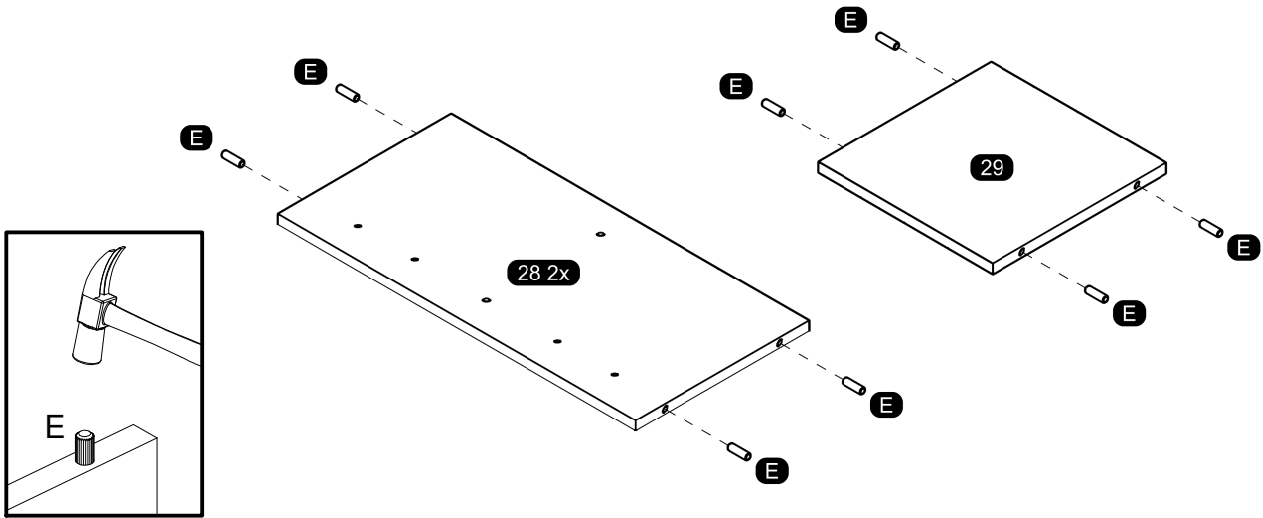

02

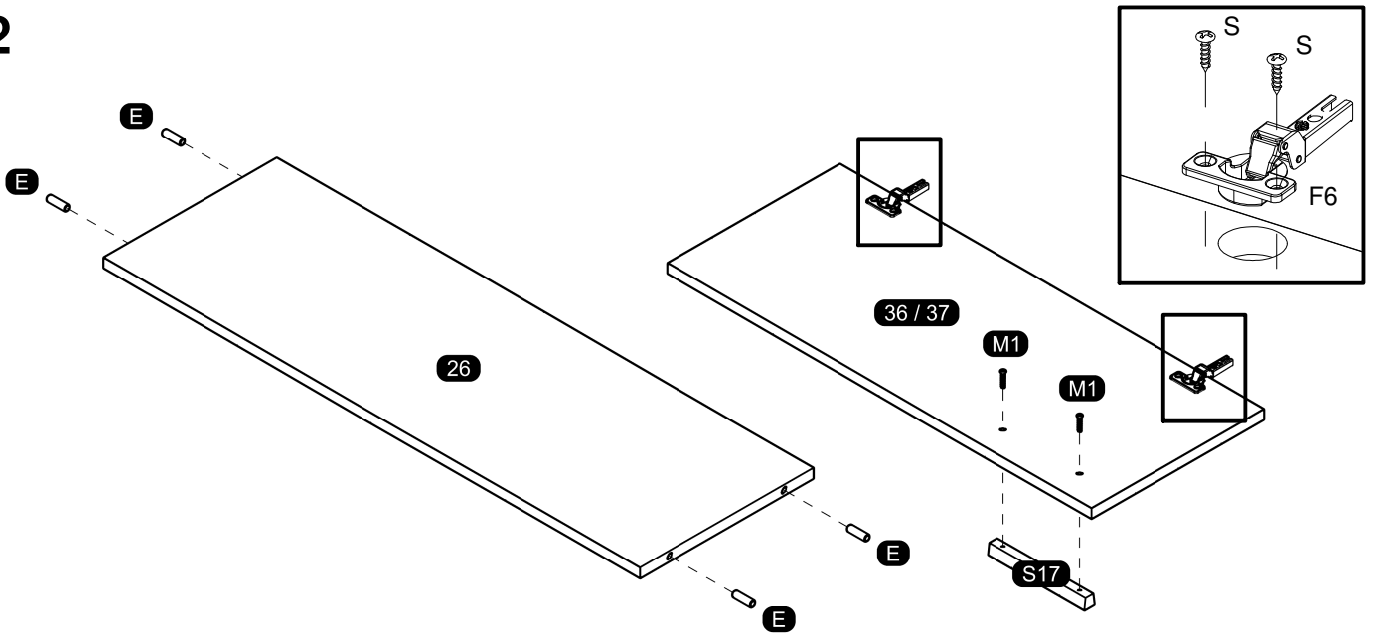

03

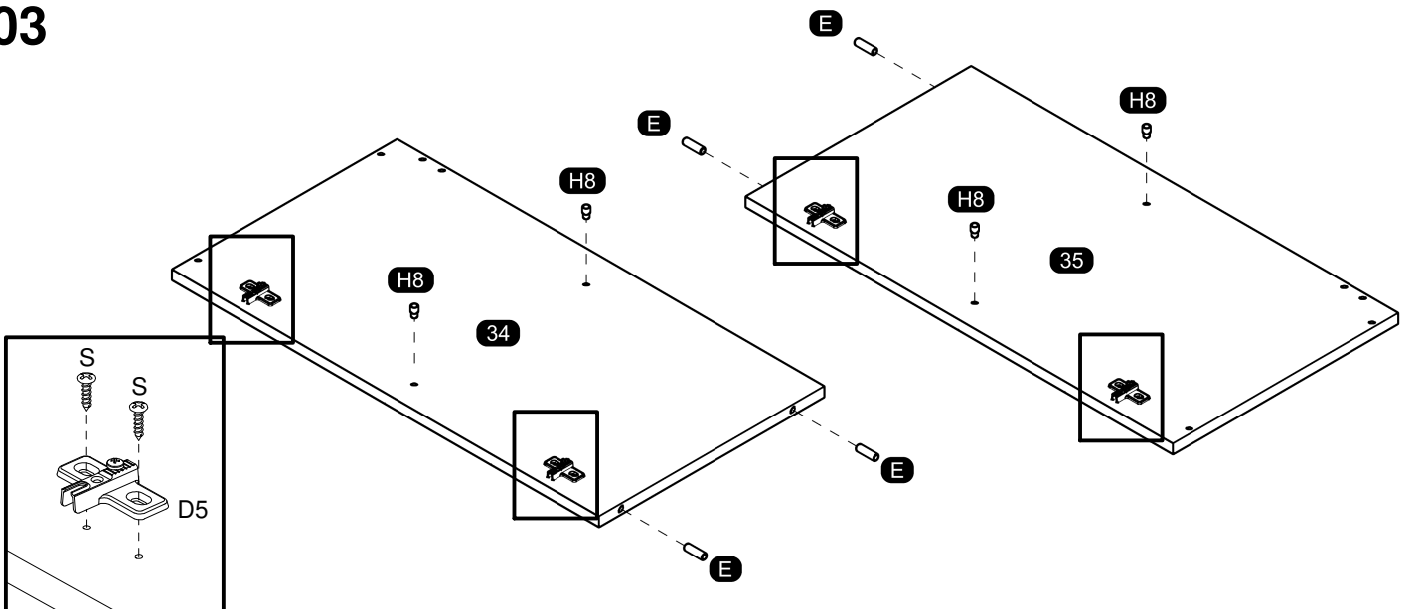

ASSEMBLY
MONTAGEM / ARMADO

04

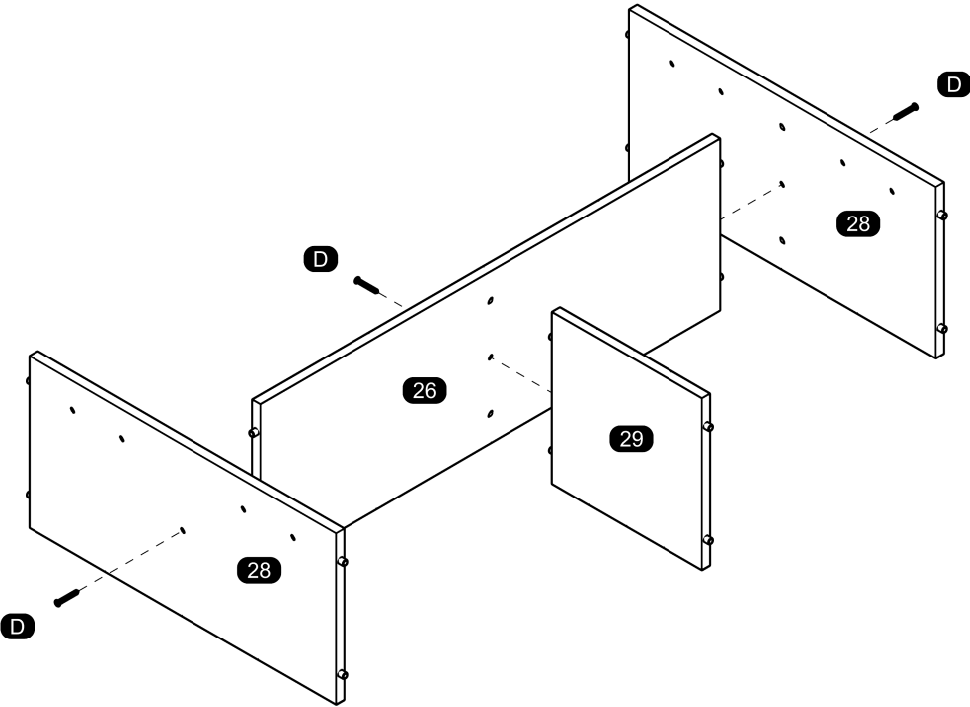

05

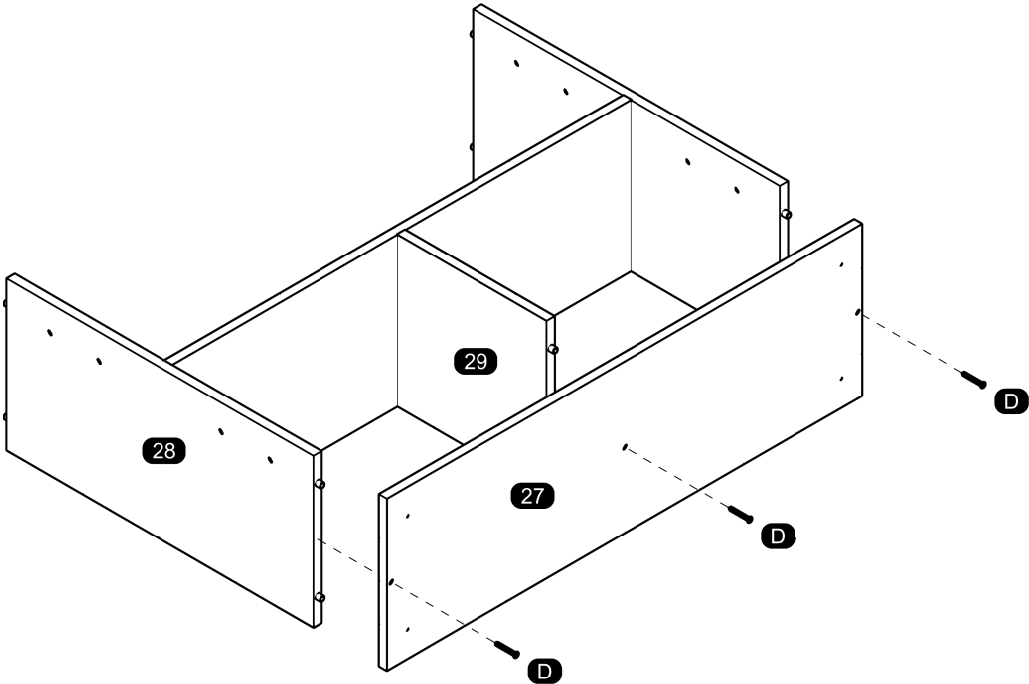

ASSEMBLY
MONTAGEM / ARMADO

06

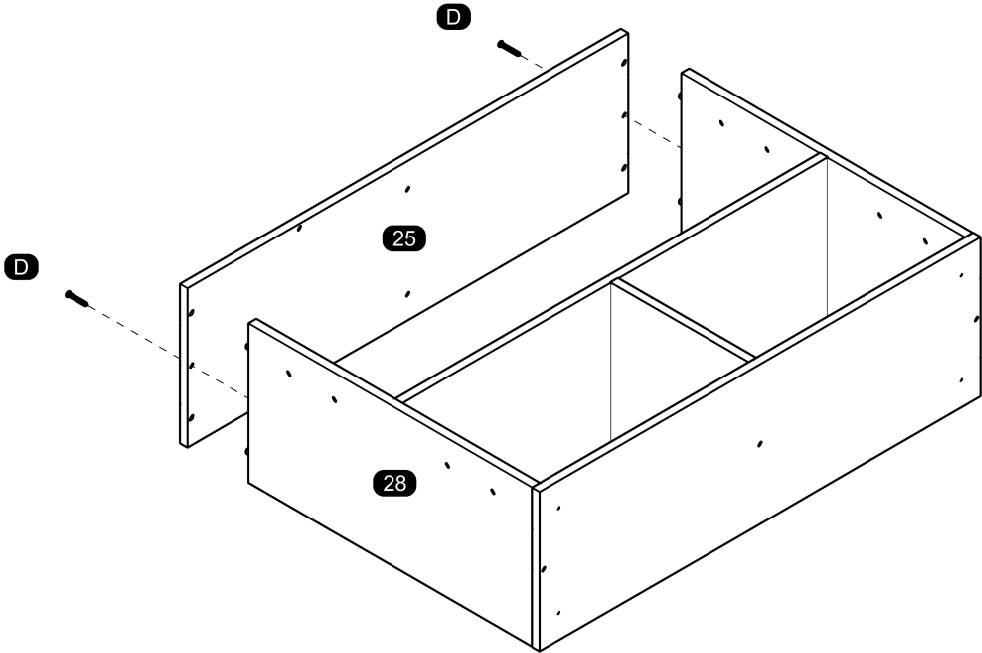

07

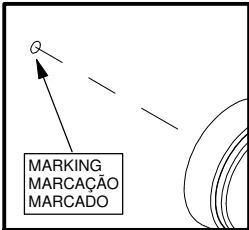
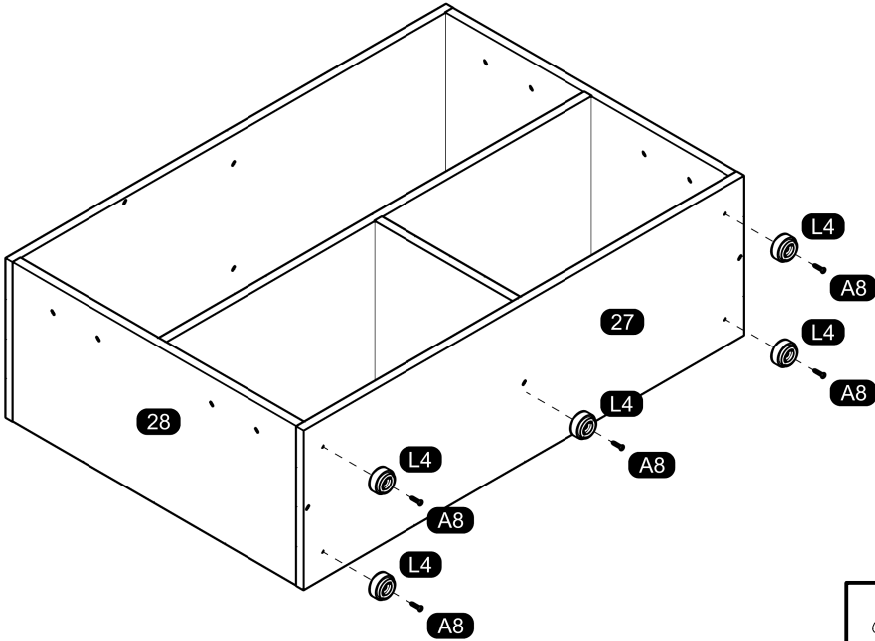

08

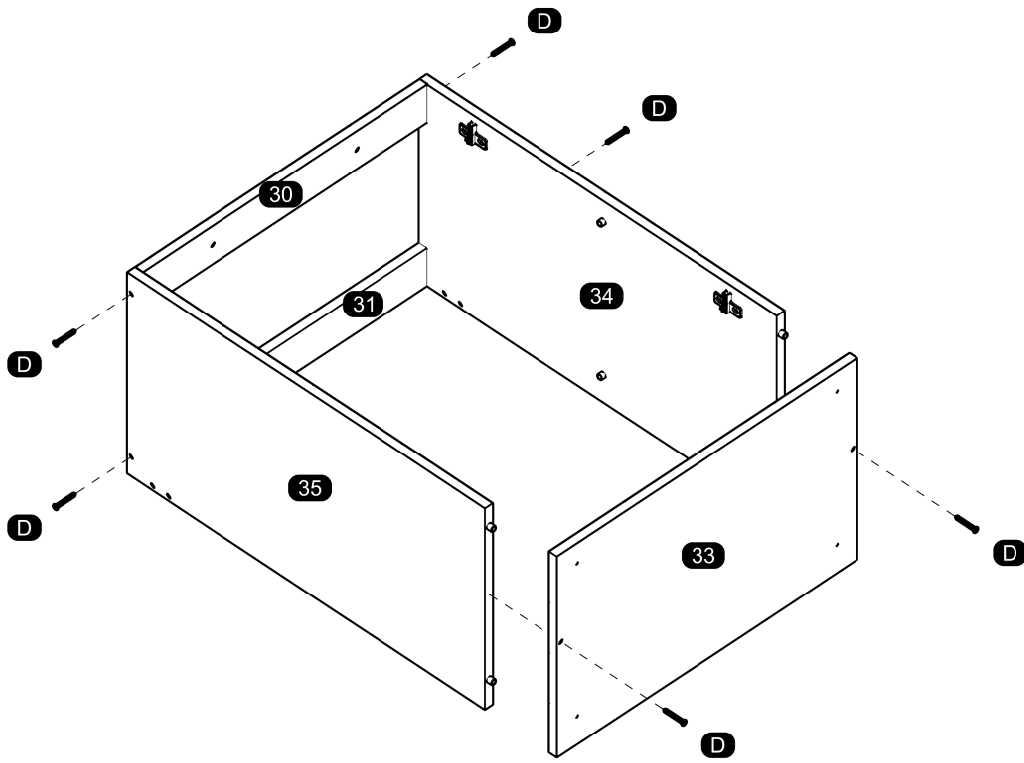

09

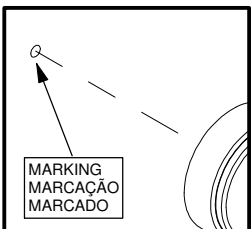
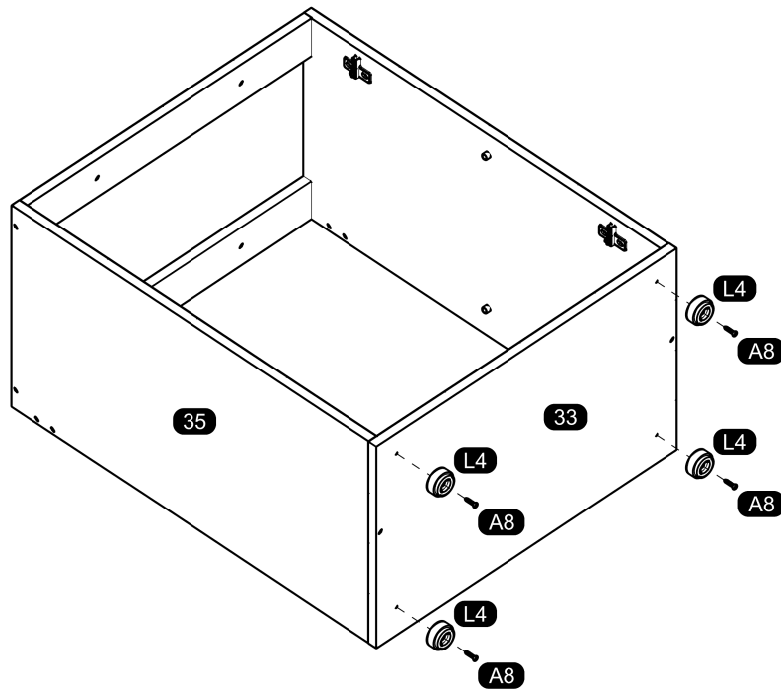

10 (E)

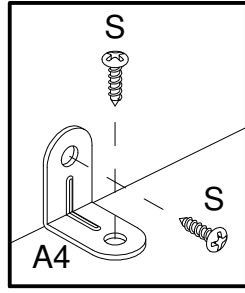

Montagem Esquerda
Left Assembly
Montaje Izquierda

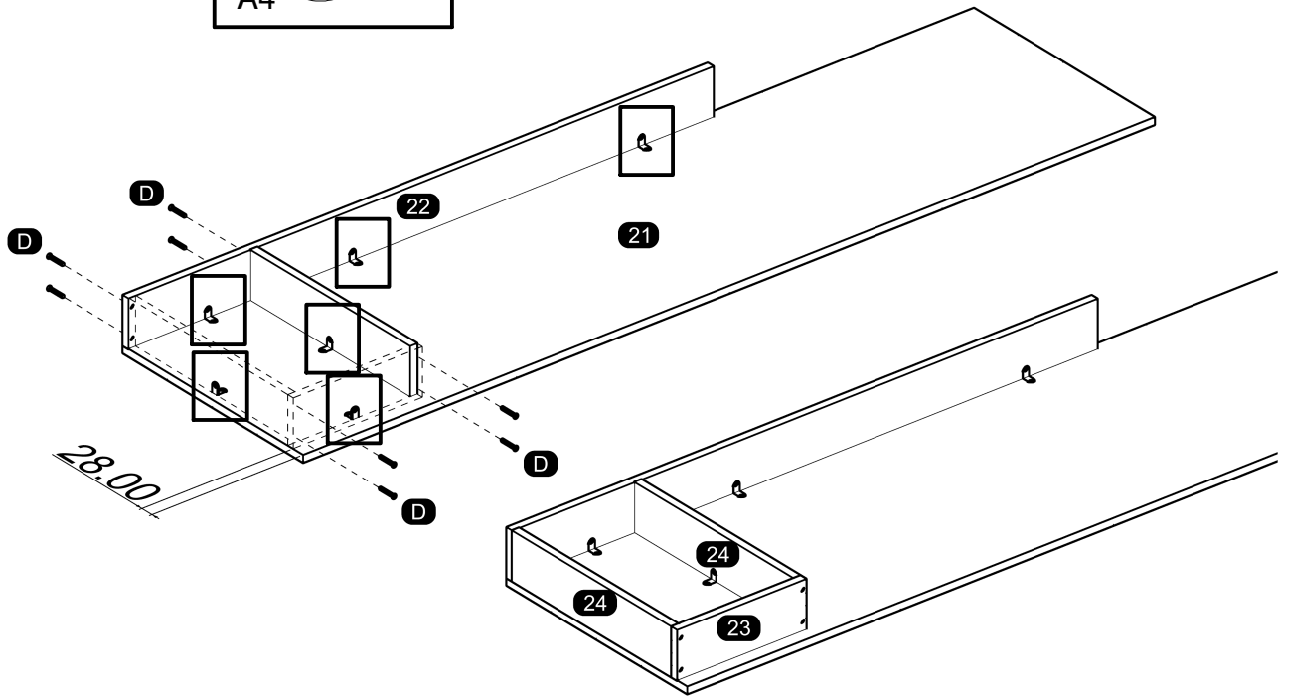

11 (E)

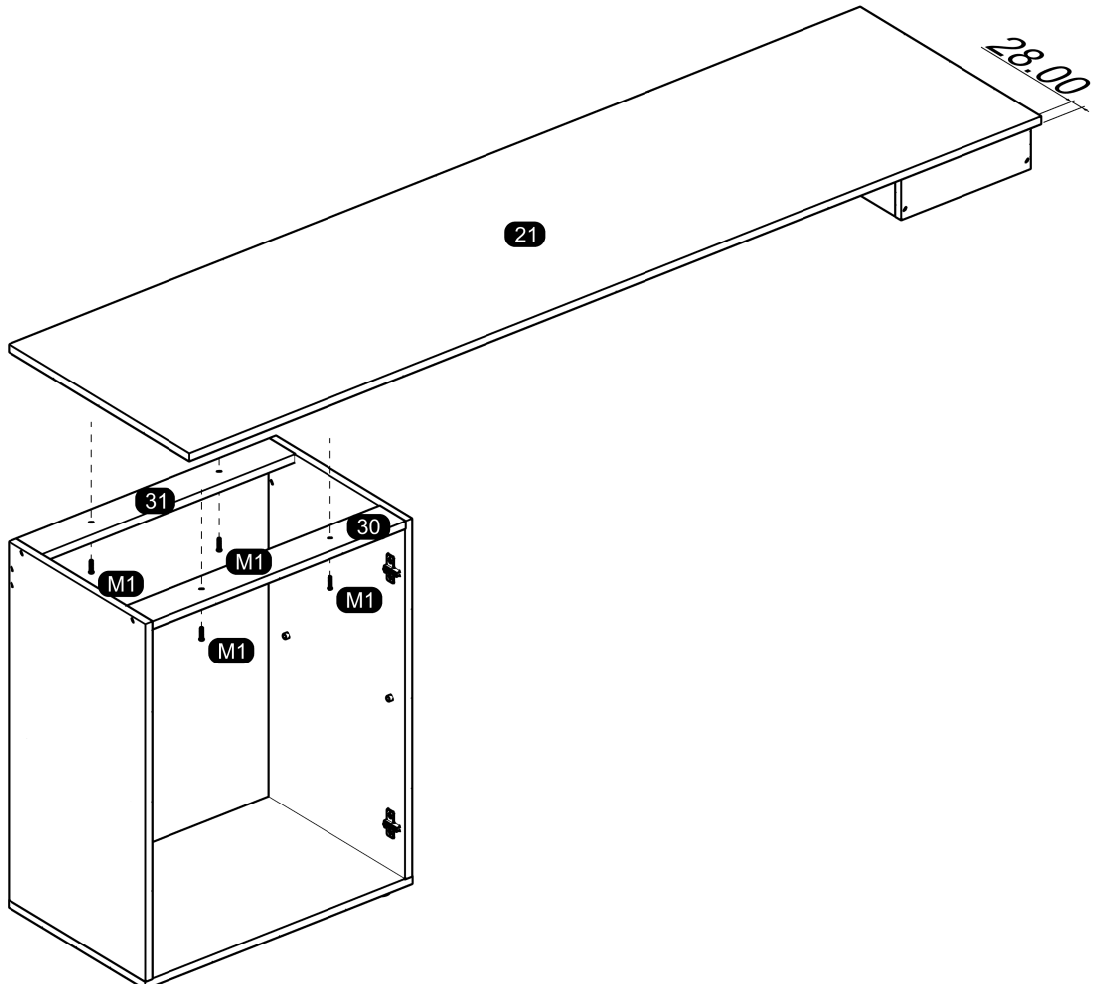

12 (D)

Montagem Direita
Right Assembly
Montaje Derecha

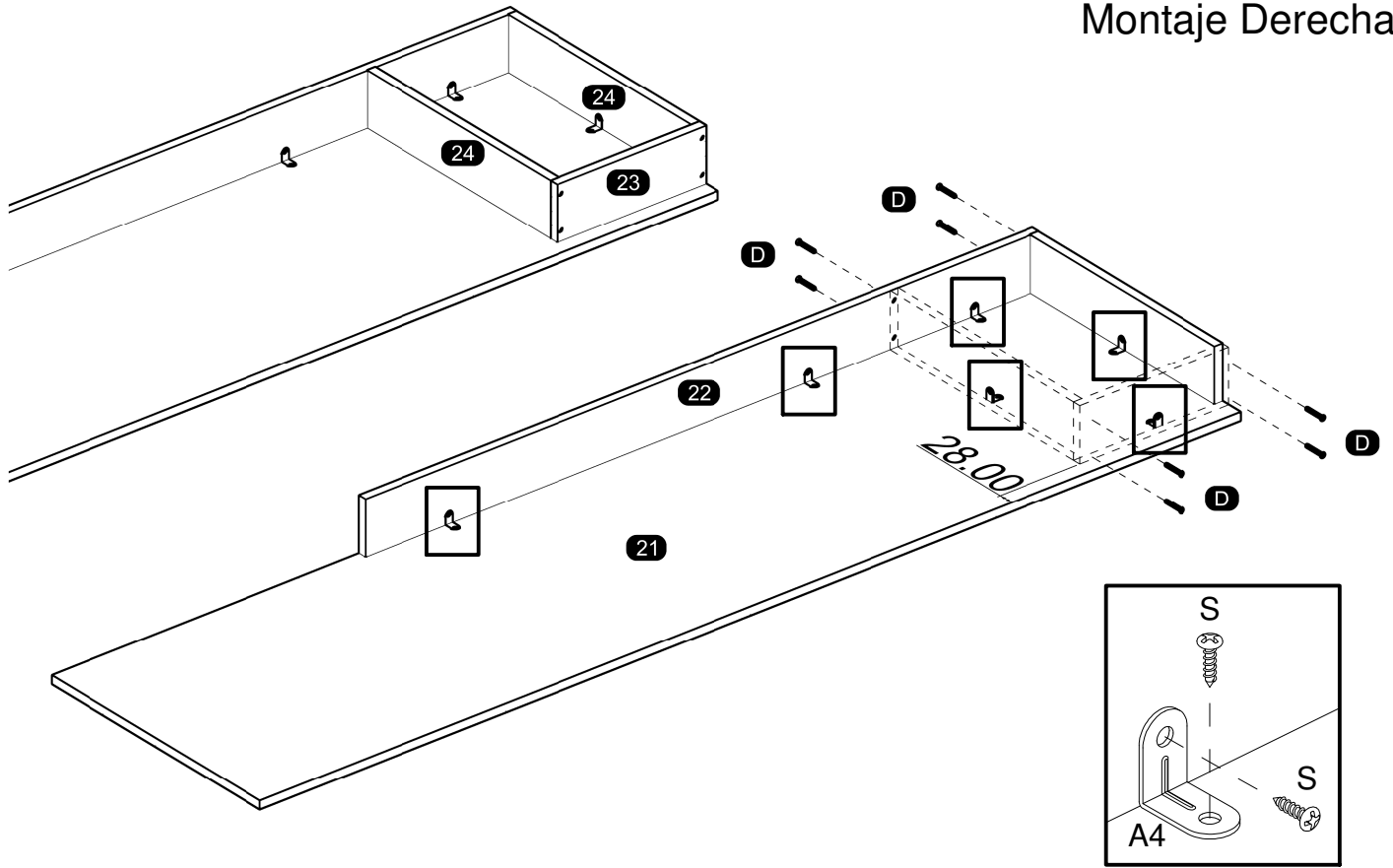

13 (D)

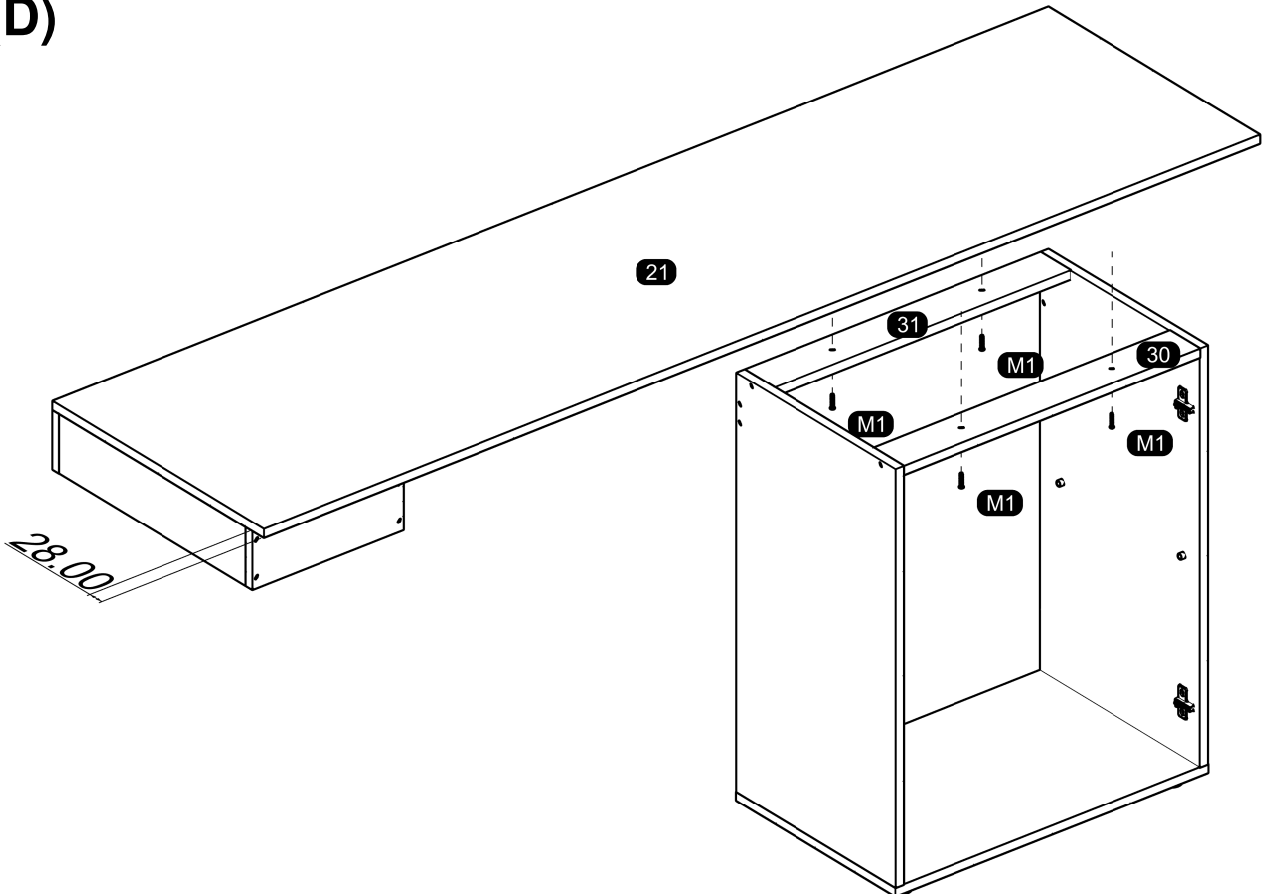

14

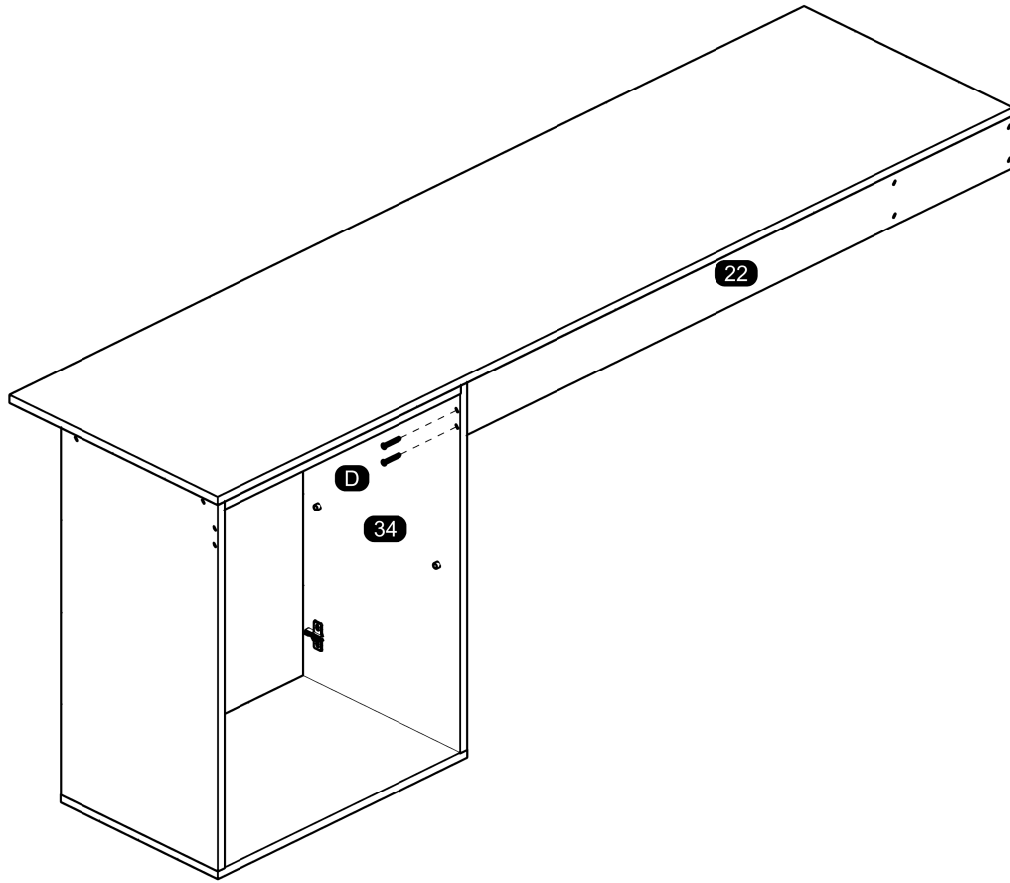

15

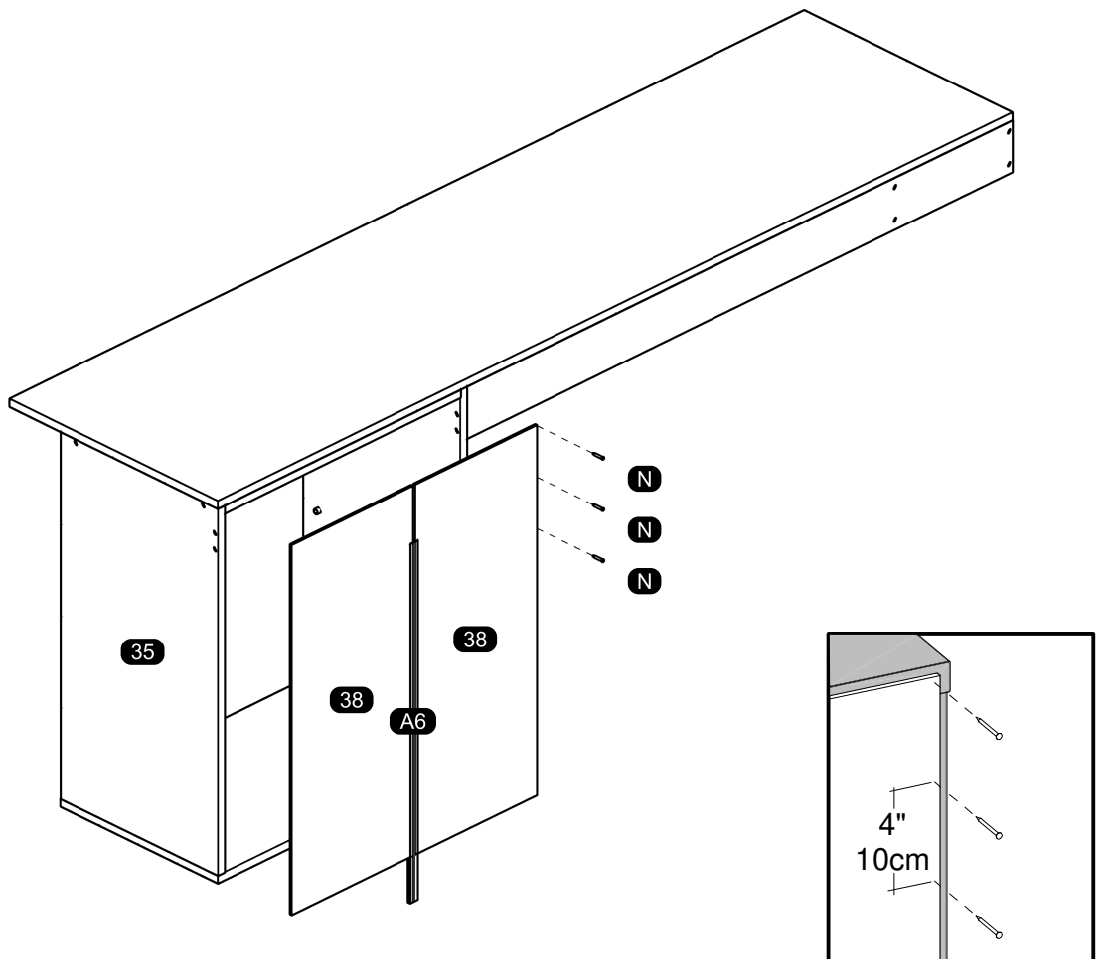

16

Montagem Esquerda
Left Assembly
Montaje Izquierda

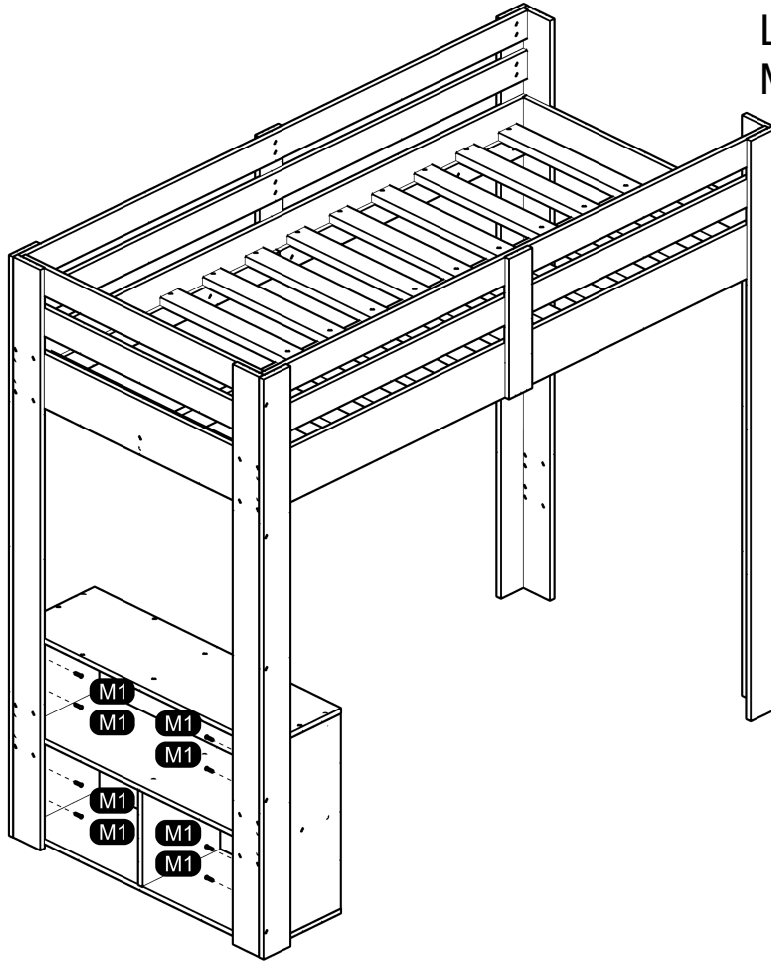

17

Montagem Direita
Right Assembly
Montaje Derecha

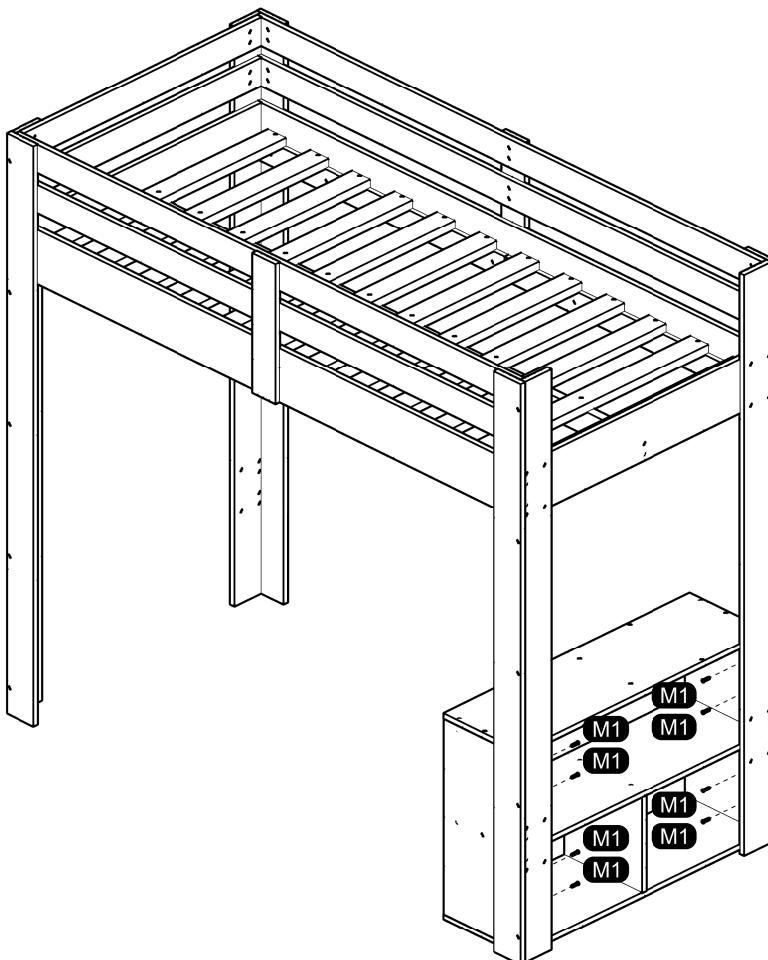

18

Montagem Esquerda
Left Assembly
Montaje Izquierda

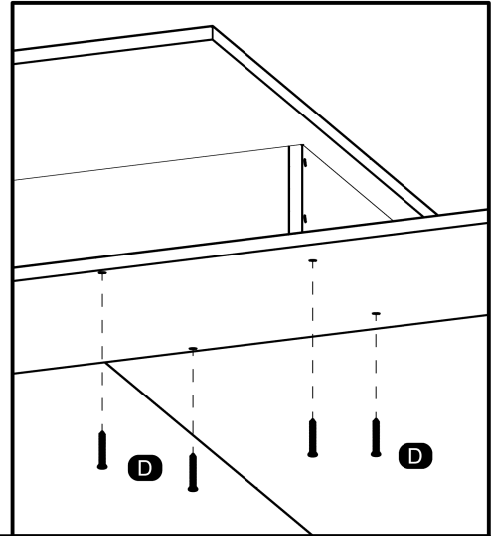
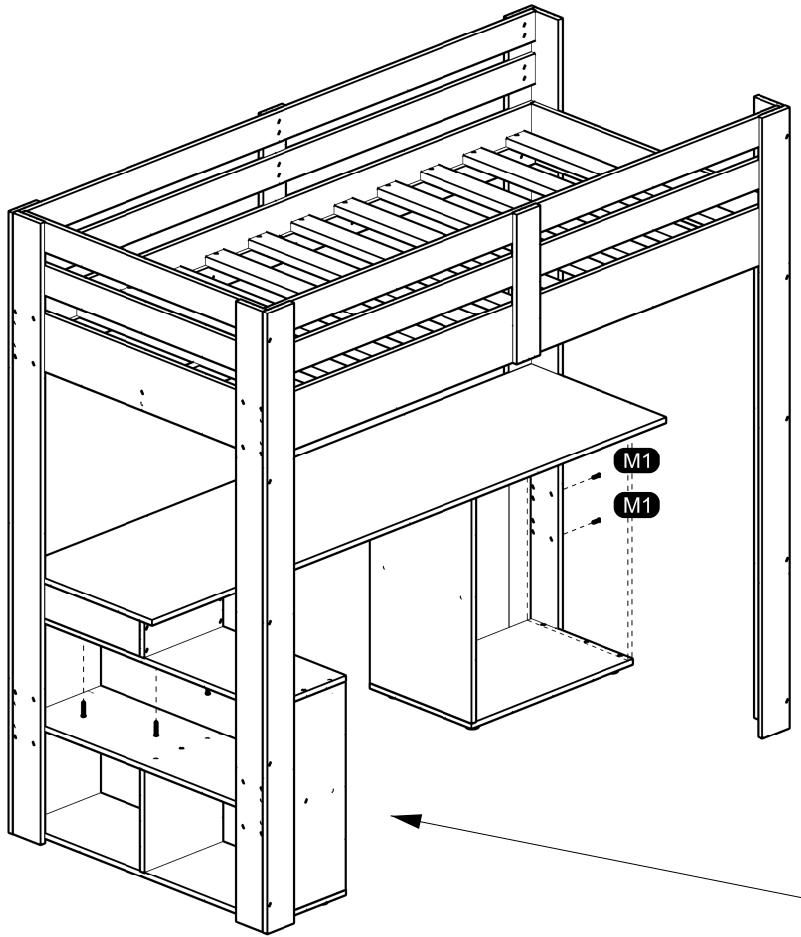

19

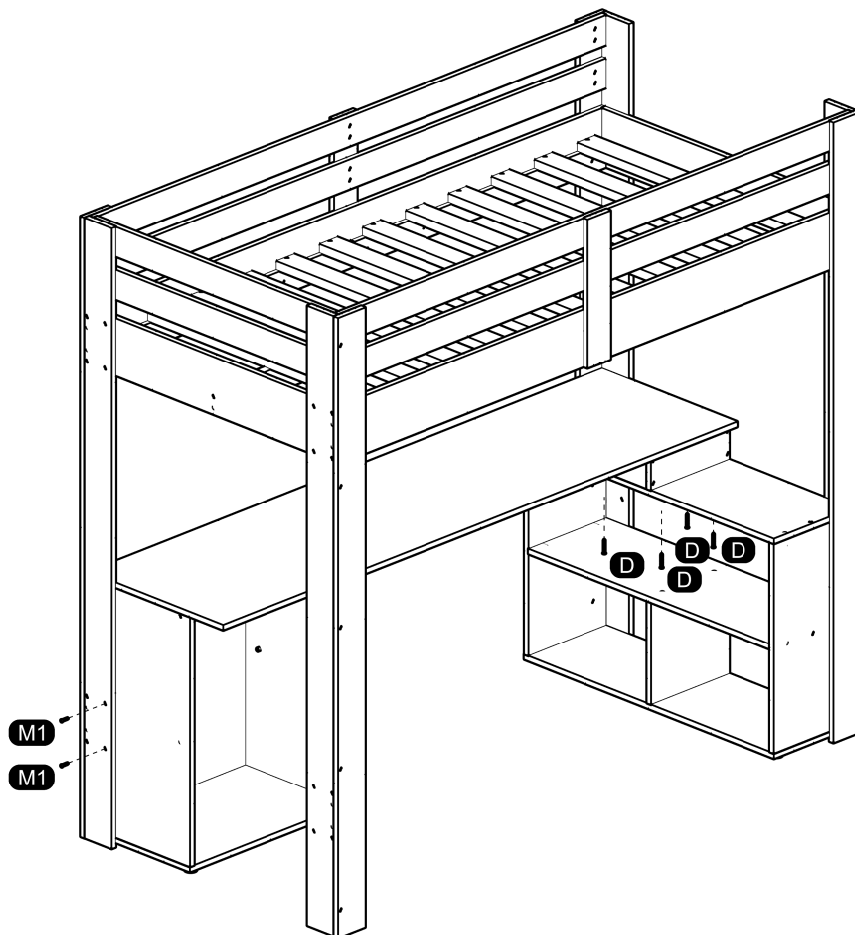

Montagem Direita
Right Assembly
Montaje Derecha

20

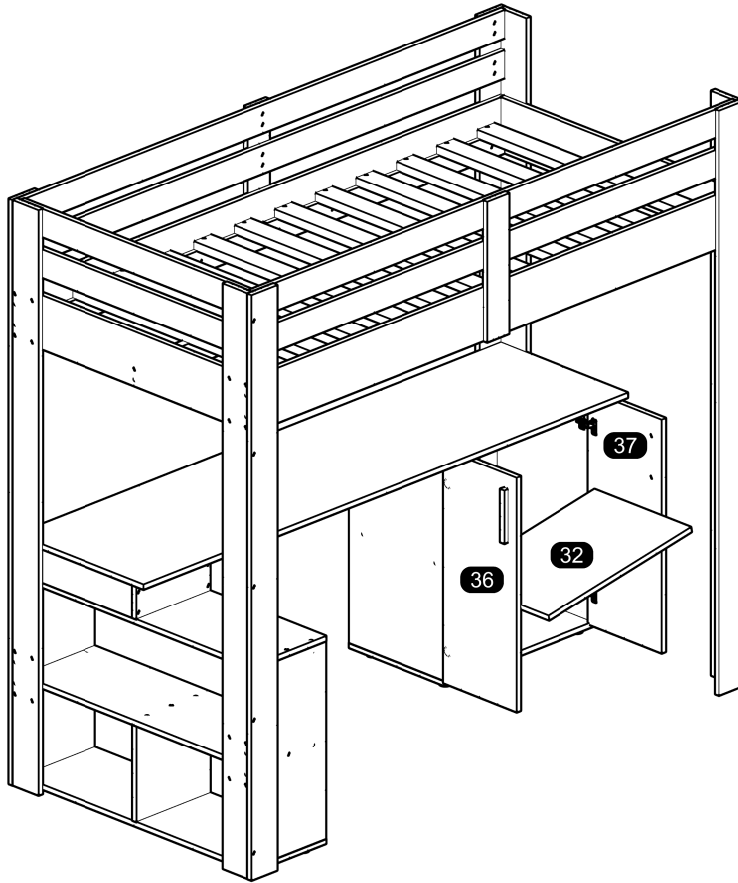

Montagem Esquerda
Left Assembly
Montaje Izquierda

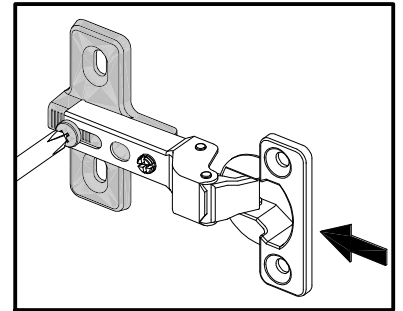

At the end of the assembly, insert the screw cover / hole plugs in the apparent holes.
Ao final da montagem, insira a(s) tampa(s) de parafuso / tapa furos nos furos que ficarem aparentes.
Al final del conjunto, coloque la tapa tornillo / tapón plástico en los agujeros que se hagan evidentes.

21

Montagem Direita
Right Assembly
Montaje Derecha

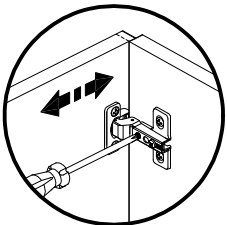

Horizontal Adjustment
Regulagem Horizontal
Ajuste Horizontal

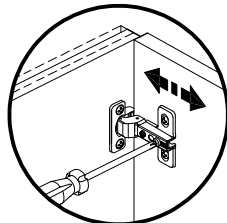

Depth Adjustment
Regulagem Profundidade
Ajuste Profundidad

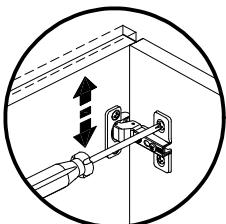

Vertical Adjustment
Regulagem Vertical
Ajuste Vertical

