

17º PASSO | PASS | PASO

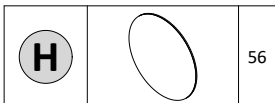

Colar tampa furo adesivo nos parafusos das molduras
 Attach adhesive hole plug to frame screws
 Pegue a tampa do orifício adesivo em los tornillos del marco

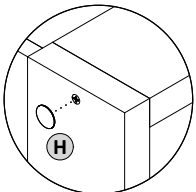

Colar tampa furo adesivo nos parafusos externos
 Attach adhesive hole plug to external screws
 Pegue la tampa del orificio adhesivo en los tornillos externos

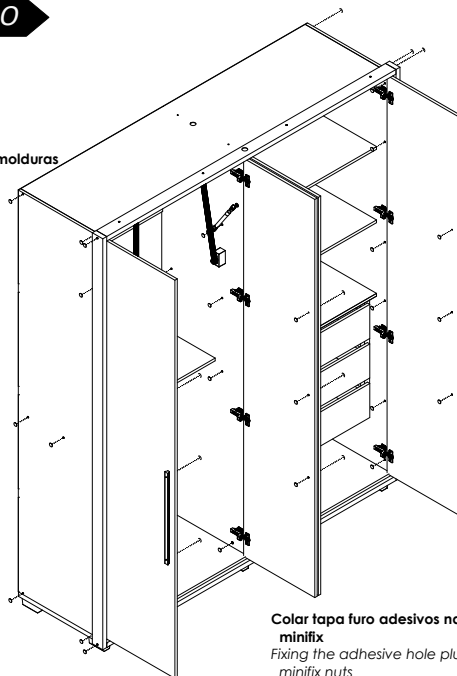
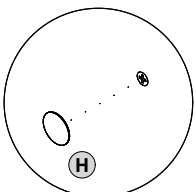

Colar tampa furo adesivos nos parafusos internos
 Attach adhesive hole plugs to the internal screws
 Pegar pegatinas en los agujeros tornillos internos

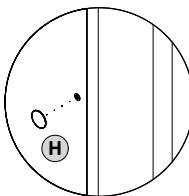

Colar tampa furo adesivos nas castanhas minifix
 Fixing the adhesive hole plugs to the minifix nuts
 Pegar tampa de orificio adhesivo en tuercas minifix

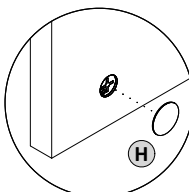

PESO SUPORTADO | SUPPORTED WEIGHT | PESO SOPORTADO

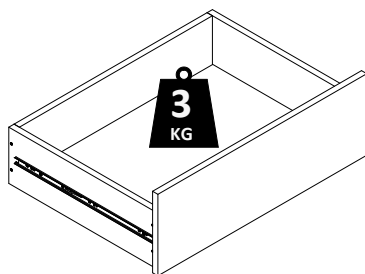
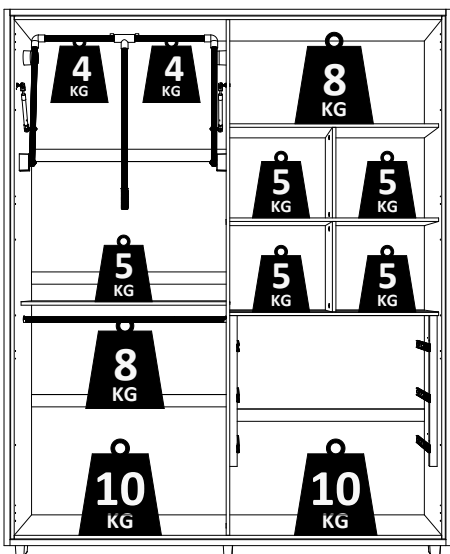

CUIDADOS ESPECIAIS | SPECIAL CARES | CUIDADOS ESPECIALES:

LIMPEZA MADEIRA: Pano limpo umedecido em água e sabão neutro - **BRILHO:** Flanela seca
CLEANING: Clean cloth humidified in water and neutral soap - **SHINE:** Dry flannel
LIMPIEZA: Tela limpia humedecida en la agua y el jabón neutro - **BRILLO:** Franela seca

Data última atualização
 Last update
 Fecha de última actualización
06.08.2025

181 - GUARDA-ROUPA GRECO
WARDROBE | ROPERO



ESQUEMA DE MONTAGEM | ASSEMBLY INSTRUCTIONS | ESQUEMA DE MONTAJE

ASPECTO FINAL | FINAL ASPECT



ESPAZZO

É tudo.
 E um pouco mais.

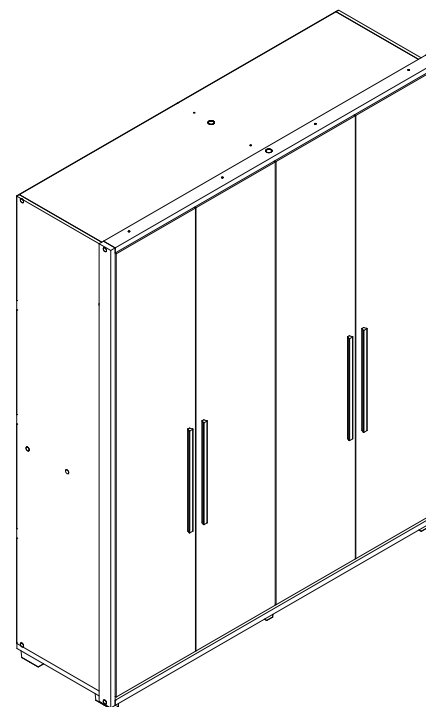

Pessoas necessárias para montagem
 People required for assembly
 Personas necesarias para el montaje



Ferramentas necessárias para montagem (não fornecidas)
 Tools required for assembly (not provided)

Herramientas necesarias para el montaje. (no proporcionado)

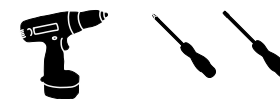

Parafusadeira ou chave de fenda e philips
 Screwdriver or Phillips screwdriver
 Destornillador o destornillador y Phillips



Martelo | Hammer | Martillo



Trena | Measuring tape | Cinta métrica

INSTRUÇÕES | INSTRUCTIONS | INSTRUCCIONES

- Prepare a montagem do móvel próximo ao local que ele ficará definitivamente e evite deslocá-lo depois de montado;
 - Forre o chão com papelão ou similar e utilize a isomanta que vem entre as peças para evitar o contato entre elas durante a montagem;
 - Monte o móvel obedecendo a ordem numérica da **seqüência de montagem (S.M.)**, identificando as peças pelo **código de peça (C.P.)** carimbado na mesma.

- Prepare the assembly of the close piece of furniture to the place that it will be definitively and avoid to move after done. Will be definitively and avoid to move after done;
 - Cover the ground with cardboard or similar and use the isomanta that it comes among the pieces to avoid the contact among them during the assembly;
 - Set up the piece of furniture obeying the numeric order of the **assembly sequence (S.M.)**, identifying the pieces by **code of piece (C.P.)** stamped in the same.

- Prepare la montaje del mobiliario proximo al lugar que estará definitivamente y evite mover después de hecho;
 - Tape la tierra con el cartón o similar y use la "isomanta" que viene entre las piezas para evitar el contacto entre ellos durante la montaje;
 - Monte el mobiliario obedeciendo la orden numérica de la **sucesión de montaje (S.M.)**, identificando las piezas por el **código de piezas (C.P.)** de la misma estampado en esta.



Atendimento ao consumidor | Attendance to the consumer | Asistencia al consumidor
 tel +55 43 3303 1800
 madetec@madetec.com.br

Madetec Móveis Ltda.
 Rua Rouxinol 5205 | Parque Industrial IV
 CEP 86706-418 | Arapongas | PR | Brasil
 www.madetec.com.br

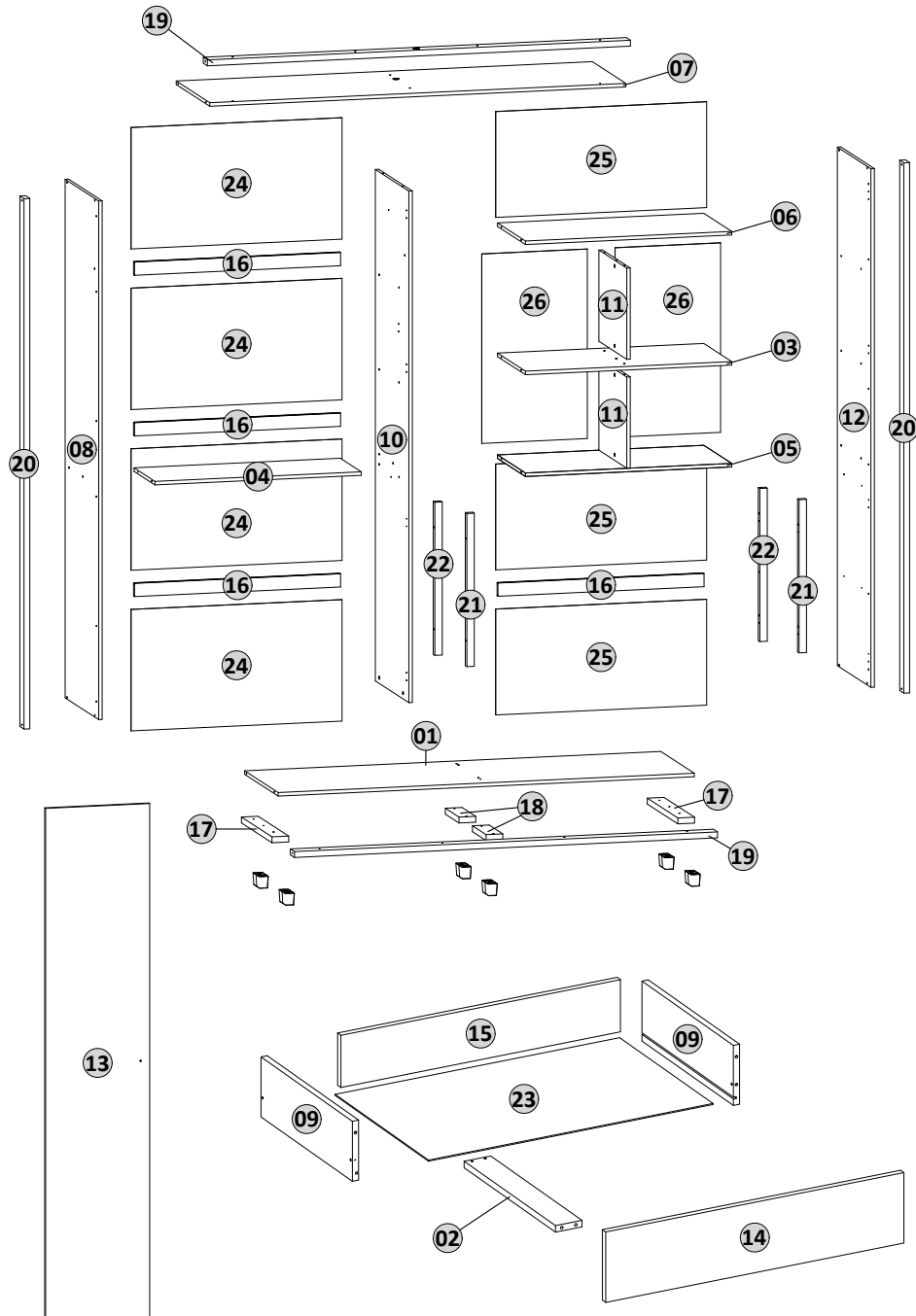
CÓDIGO DE PEÇAS | CODE OF PIECES | CÓDIGO DE PIEZAS

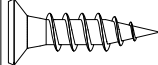

15º PASSO | PASS | PASO

G		32
S		16

**MONTAGEM PORTA
DOOR ASSEMBLY
CONJUNTO DE PUERTA**

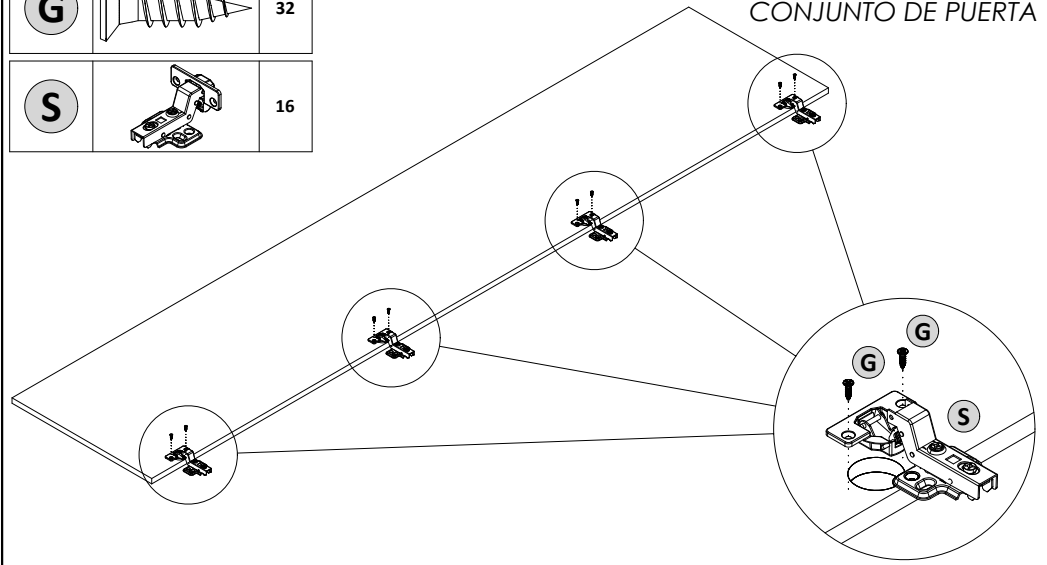

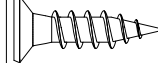

16º PASSO | PASS | PASO

PEÇAS PIECES PIEZAS	G		64
------------------------------------	----------	---	----

S.M.	C.P.
01	13
02	13
03	13
04	13

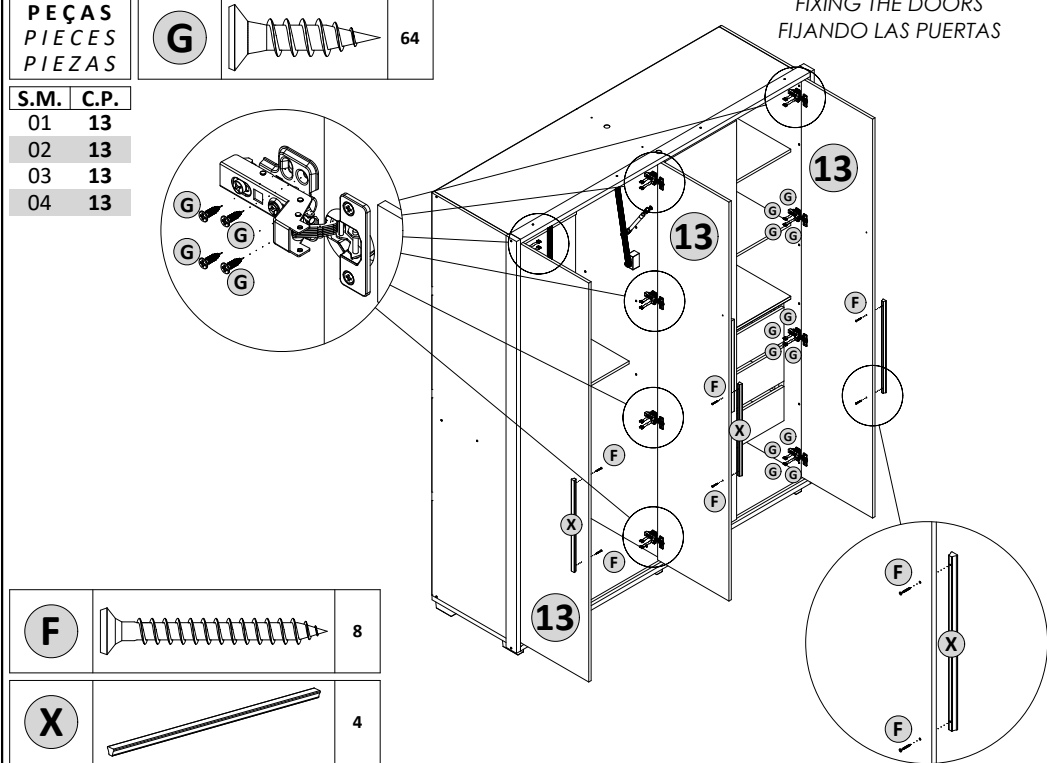
**FIXANDO AS PORTAS
FIXING THE DOORS
FIJANDO LAS PUERTAS**

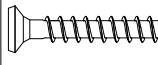

F		8
X		4

ATENÇÃO!!

Fixar os cabideiros extensíveis antes de colocar as portas

ATTENTION!!

Fix the pull-out hangers before installing the doors

ATENCION!!

Coloque las perchas extensibles antes de colocar las puertas

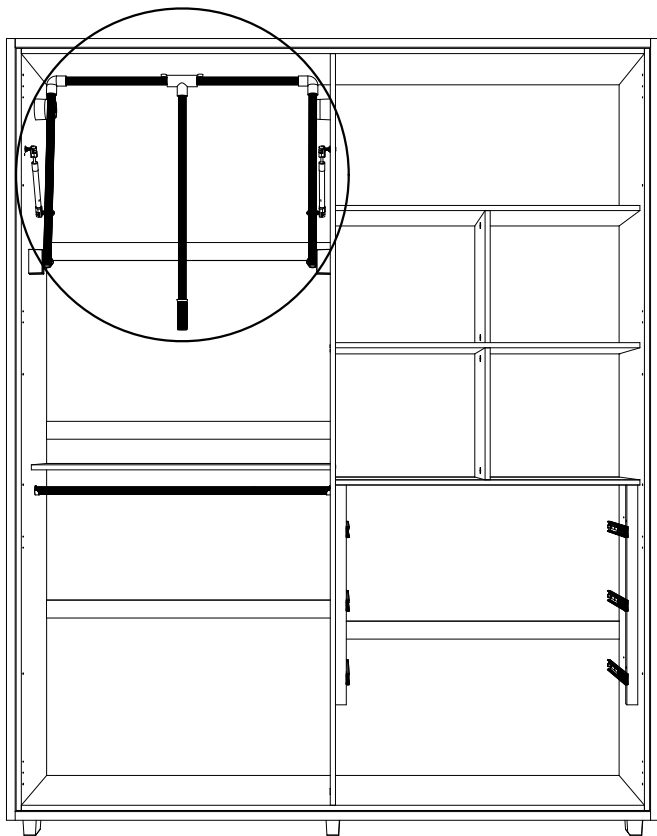

REF.:	CÓDIGO DA PEÇA PART CODE CÓDIGO DE PIEZA			DESCRIÇÃO DA PEÇA PART DESCRIPTION DESCRIPCIÓN DE PIEZA	MATERIA PRIMA FEEDSTOCK	DIMENSÕES DIMENSIONS DIMENSIONES	QUANT. AMOUNT CANTIDAD
	CINAMOMO	CUMARU	CINAMOMO OFF WHITE				
1	204374.037	204374.039	204374.037	204374.039	Base Base Base	1795 x 540 x 15	1
2	204223.009	204223.009	204223.009	204223.009	Travessa da gaveta Drawer crossbar Bandeja del cajón	415 x 62 x 15	3
3	204375.037	204375.039	204375.037	204375.039	Prateleira da colmeia Hive shelf Estante de colmena	890 x 450 x 15	1
4	204376.037	204376.039	204376.037	204376.039	Prateleira do cabideiro Clothes rack shelf Estante del perchero	890 x 337 x 15	1
5	204377.037	204377.039	204377.037	204377.039	Base da colmeia Base of the hive Base de la colmena	890 x 450 x 15	1
6	204378.037	204378.039	204378.037	204378.039	Tampo da colmeia Hive top Tapa de la colmena	890 x 450 x 15	1
7	204379.037	204379.039	204379.037	204379.039	Chapéu Top panel Panel superior	1795 x 540 x 15	1
8	204380.037	204380.039	204380.037	204380.039	Lateral esquerda Left side panel Panel lateral izquierdo	2195 x 540 x 15	1
9	204014.037	204014.039	204014.037	204014.039	Lateral de gaveta Drawer side panel Panel lateral del cajón	415 x 138 x 15	6
10	204381.037	204381.039	204381.037	204381.039	Divisão central Central division División central	2165 x 540 x 15	1
11	204382.037	204382.039	204382.037	204382.039	Divisão da colmeia Division of the hive División de la colmena	449 x 386 x 15	2
12	204383.037	204383.039	204383.037	204383.039	Lateral direita Right side panel Panel lateral derecho	2195 x 540 x 15	1
13	204384.037	204384.039	204384.026	204384.040	Porta Door Puerta	2175 x 449 x 15	4
14	204385.037	204385.039	204385.037	204385.039	Fronte de gaveta Drawer front panel Panel frontal del cajón	815 x 186 x 15	3
15	204302.037	204302.039	204302.037	204302.039	Contra fundo de gaveta Drawer back panel Panel trasero del cajón	771 x 120 x 15	3
16	204212.037	204212.039	204212.037	204212.039	Perfil H maior Larger H-profile Perfil H más grande	889 x 56 x 15	4
17	204242.037	204242.039	204242.037	204242.039	Rodapé lateral Side support of the base Soporte lateral de la base	492 x 72 x 25	2
18	204243.009	204243.009	204243.009	204243.009	Rodapé central Central base support Soporte base central	220 x 72 x 25	2
19	204386.037	204386.039	204386.037	204386.039	Moldura inferior/superior Bottom/Top Frame Bisel inferior/superior	1825 x 66 x 25	2
20	204387.037	204387.039	204387.037	204387.039	Moldura lateral Side frame Marco lateral	2245 x 66 x 25	2
21	204388.037	204388.039	204388.037	204388.039	Distanciador de gav. fron. Front drawer stander Saciador de cajón frontal	648 x 32 x 25	2
22	204389.009	204389.009	204389.009	204389.009	Distanciador de gav. tras. Rear drawer stander Saciador de cajón trasero	648 x 32 x 25	2
23	204305.037	204305.039	204305.037	204305.039	Fundo de gaveta drawer bottom Fondo del cajón	784 x 420 x 3	3
24	204390.037	204390.039	204390.037	204390.039	Fundo lateral esquerdo Left side bottom Fondo lateral izquierdo	910 x 514 x 3	4
25	204391.037	204391.039	204391.037	204391.039	Fundo lateral direito Right side bottom Fondo lateral derecho	910 x 448 x 3	3
26	204392.037	204392.039	204392.037	204392.039	Fundo central colmeia Central bottom of the hive Fondo central de la colmena	802 x 455 x 3	2

LEGENDA DAS CORES | COLOR LEGEND | LEYENDA DE COLOR

009 - SEM PINTURA | UNPAINTED | SIN PINTAR

026 - OFF WHITE

037 - CINAMOMO

039 - CUMARU

040 - OPALA

ACESSÓRIOS | ACCESSORIES

PARAFUSOS | Screw | Tornillo

CÓDIGO | CODE

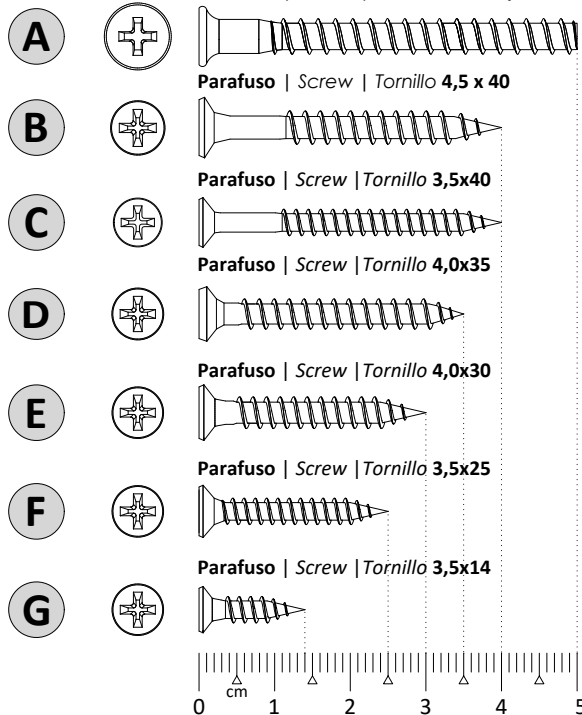

A Parafuso | Screw | Tornillo 5,0x50 (Estrutural) 28x 102100045

B Parafuso | Screw | Tornillo 4,5 x 40 12x 102100001

C Parafuso | Screw | Tornillo 3,5x40 26x 102100012

D Parafuso | Screw | Tornillo 4,0x35 18x 102100038

E Parafuso | Screw | Tornillo 4,0x30 12x 102100005

F Parafuso | Screw | Tornillo 3,5x25 8x 102100004

G Parafuso | Screw | Tornillo 3,5x14 164x 102100003

RELAÇÃO DE COR DOS ACESSÓRIOS

Color ratio of accessories | Relación de color de los accesorios

LETRA LETTER	DESCRIÇÃO DESCRIPTION DESCRIPCIÓN	MATÉRIA PRIMA FEEDSTOCK	COR COLOR	QUANT. AMOUNT CANTIDAD				CÓDIGO CODE
				CINAMOMO	CUMARU	CINAMOMO OFF WHITE	CUMARU OPALA	
H	Tapa furo adesivo 18mm Adhesive hole cover 18mm Tapa agujero adhesivo 18mm	Papel Paper	Cinamomo	80	68		102080286	
			Cumaru		80	68	102080288	
			Off White			12	102080216	
			Opala			12	102080289	
i	Giz p/ correção Touch-up chalk Tiza correctora	Cera Wax	Cinamomo	1	1		102140023	
			Off white			1	102140008	
			Cumaru		1	1	102140026	
			Opala			1	102140025	
J	Pé de plástico Plastic foot Pie de plastico	Plástico Plastic	Cinamomo	6	6		102110039	
			Cumaru		6	6	102110040	

13º PASSO | PASS | PASO

PEÇAS PIECES PIEZAS	C		18	G		54
---------------------------	----------	--	----	----------	--	----

S.M.	C.P.	N		18	M		6	K		3
01	14									
02	09									
03	09									
04	23									
05	15									
06	02									

MONTAGEM DAS GAVETAS | DRAWER ASSEMBLY | MONTAJE DEL CAJÓN

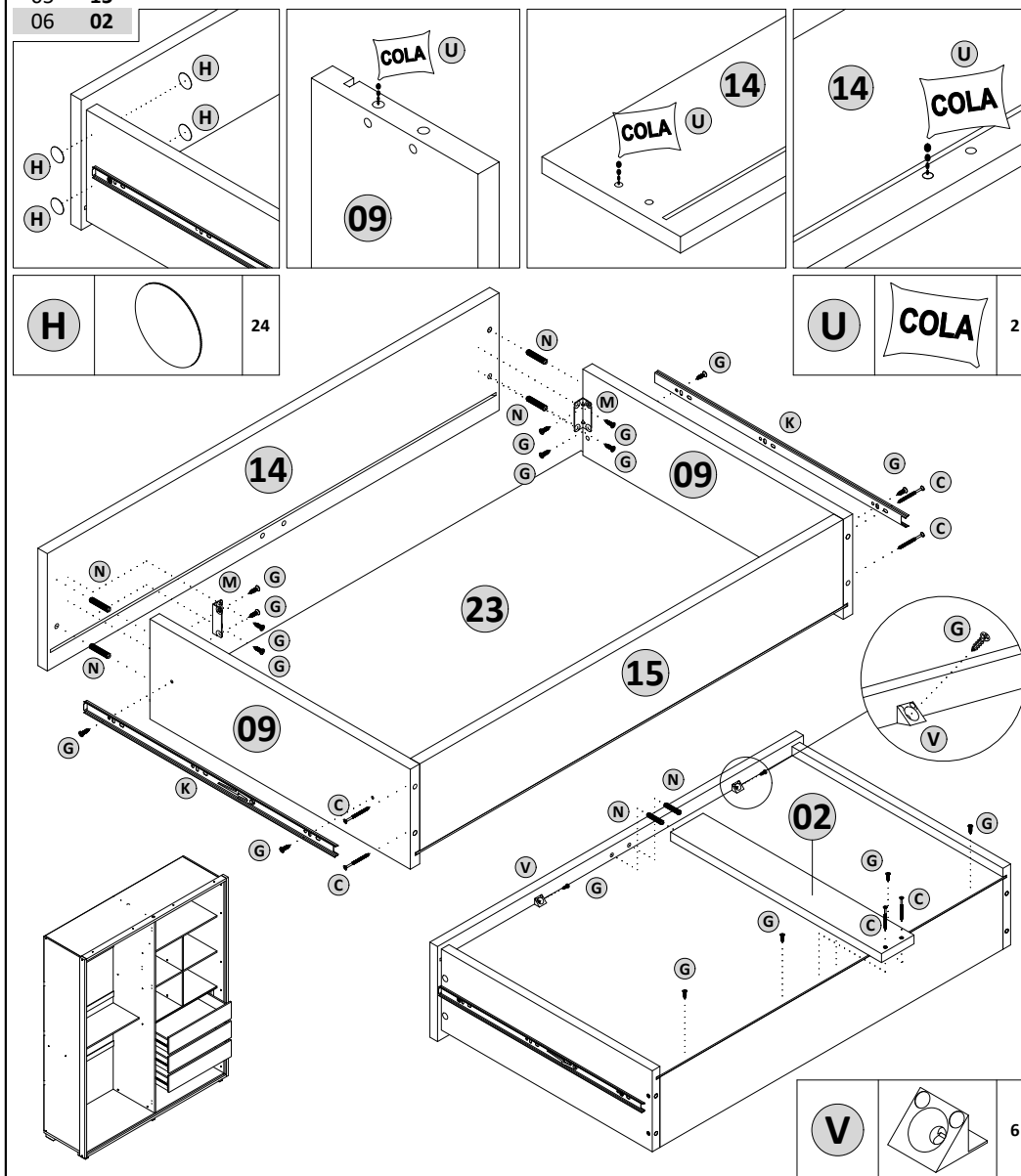

V		6
----------	--	---

PEÇAS
PIECES
PIEZAS

S.M. C.P.

01	25
02	16
03	25
04	26
05	26
06	25
07	24
08	16
09	24
10	16
11	24
12	16
13	24

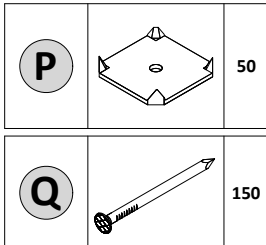









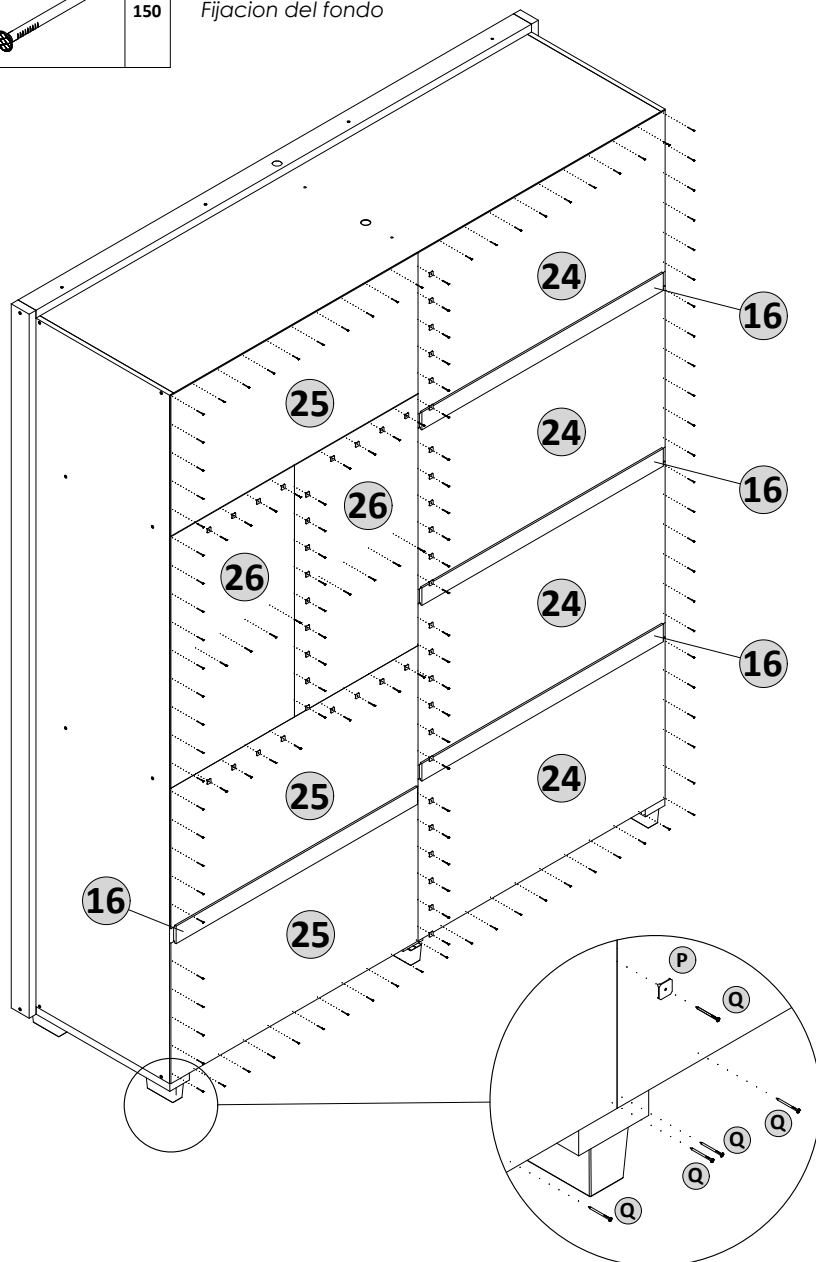

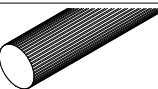

ATENÇÃO!! | ATTENTION!! | ATENCION!!

Coloque os cabideiros antes de fixar os fundos
Place the hangers before attaching the bottoms
Coloque las perchas antes de colocar los fondos

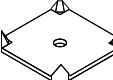
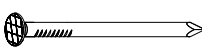
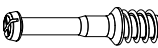
Fixação dos fundos

Back panel instalation
Fijacion del fondo

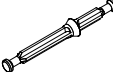

LETRA LETTER	DESCRIÇÃO DESCRIPTION DESCRIPCIÓN	MATÉRIA PRIMA FEEDSTOCK	QUANTIDADE AMOUNT CANTIDAD	CÓDIGO CODE
K	 Corrediza telescópica Drawer slide Diapositivas del cajón	Metal	3	102010026
L	 Tubo redondo estriado 884mm Ribbed round tube 884mm Tubo redondo acanalado 884mm	Metal	1	102050053
M	 Cantoneira aço 17,5x17,5x46mm zincada Angle steel 17.5x17.5x46mm zinc-plated Ángulo de acero 17,5x17,5x46mm cincado	Metal	6	102050041
N	 Cavilha 6x30mm Dowel 6x30mm Clavija 6x30mm	Madeira Wood Madera	28	102050001
O	 Castanha girofix 12x10mm Girofix chestnut 12x10mm Castaña girofix 12x10mm	Metal	6	102050006
P	 Chapa fixador de fundo Bottom fixing plate Placa fijadora de fondo	Metal	60	102050002
Q	 Prego 10x10 Nail 10x10 Clavo 10x10	Metal	183	102100009
R	 Pino girofix 5,0x30mm Girofix pin 5,0x30mm Pino girofix 5,0x30mm	Metal	4	102050007
S	 Dobradiça Curva 35mm c/ calço c/ amortecedor 35mm Curved Hinge with Damper Wedge Bisagra curva de 35 mm con almohadilla amortiguadora	Metal	16	102010056
T	 Suporte cabideiro redondo cromado Cromed round coat rack Perchero redondo cromado	Metal	2	102060155
U	 SACHE de cola 12g Sachet of glue 0,42oz Bolsita de pegamento 0,42oz	Cola Glue	2	102050020
V	 Cantoneira suporte triangular Triangle support angle Cantонера soporte triangular	Plástico Plastic	9	102050037
W	 Etiqueta resinada Resin label Etiqueta en resina	Plástico Plastic	1	102080013
X	 Perfil puxador 500mm Puller profile 500mm Perfil Tirador 500mm	Alumínio Aluminum	4	000000000
Y	 Pino girofix haste dupla 62x8mm Girofix double stem 62x8mm Giro-fijo asta doble 62x8mm	Metal	1	102050008

1º PASSO | PASS | PASO

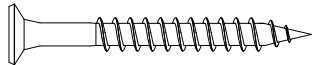
PEÇAS PIECES PIEZAS	D		14
---------------------------	----------	--	----

S.M.	C.P.
01	01
02	17
03	18
04	18
05	17
06	19

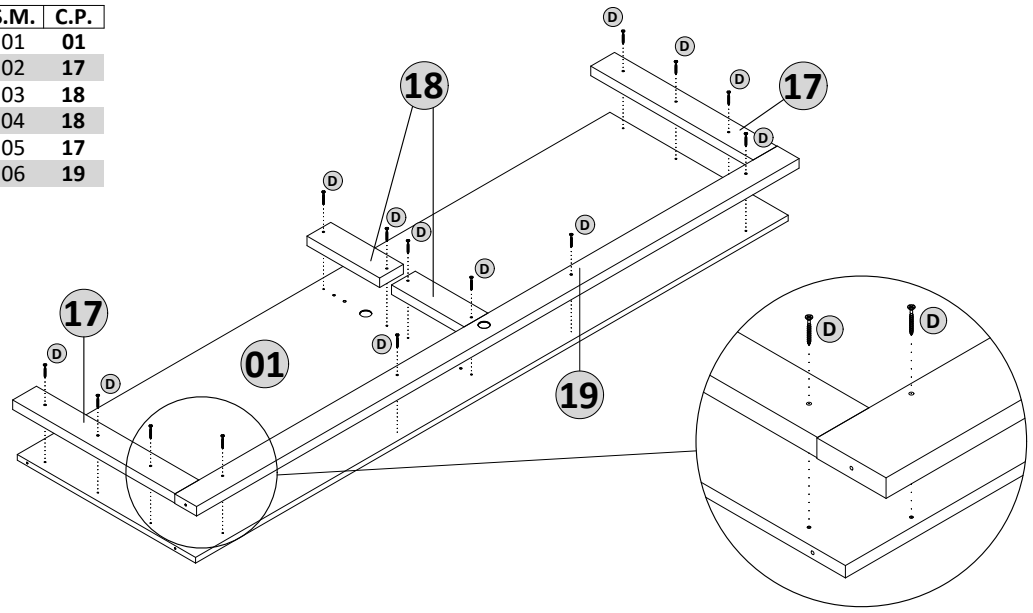

2º PASSO | PASS | PASO

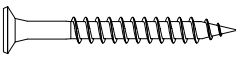
B		12
----------	---	----

J		6
----------	--	---

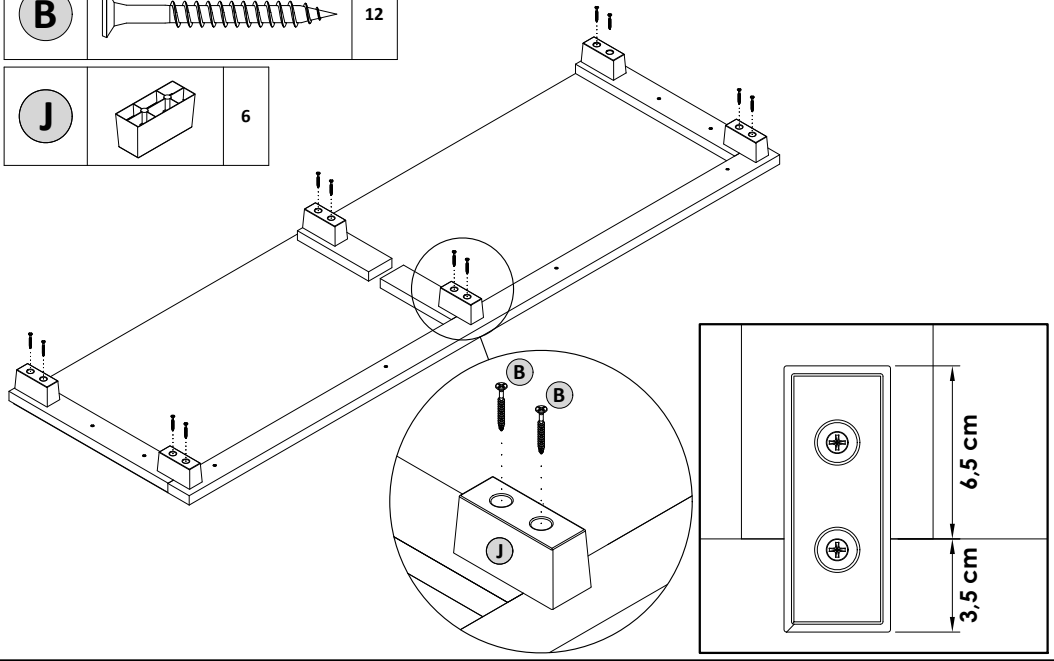

11º PASSO | PASS | PASO

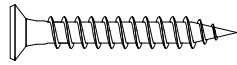
PEÇAS PIECES PIEZAS	E		12
---------------------------	----------	--	----

S.M.	C.P.
01	20
02	20

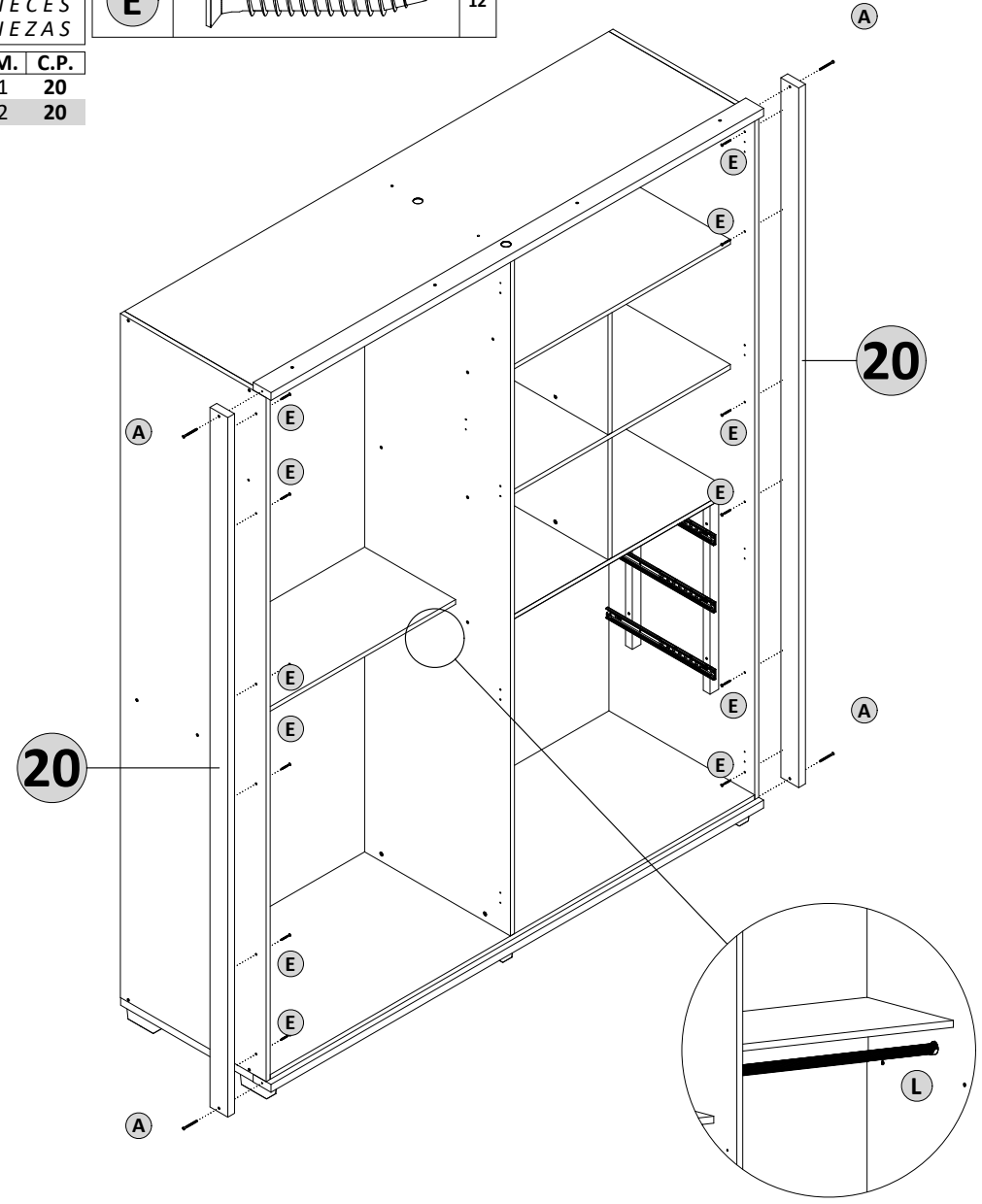

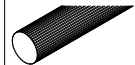
L		1
----------	---	---

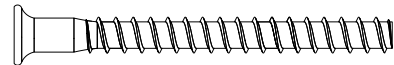
A		4
----------	---	---

9º PASSO | PASS | PASO

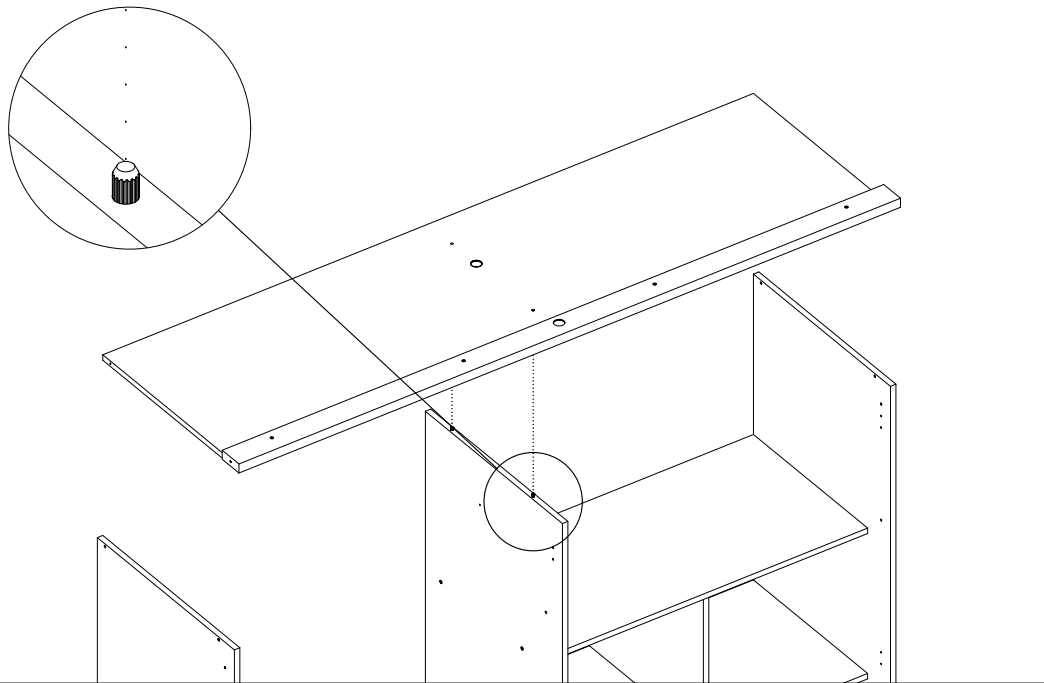

10º PASSO | PASS | PASO

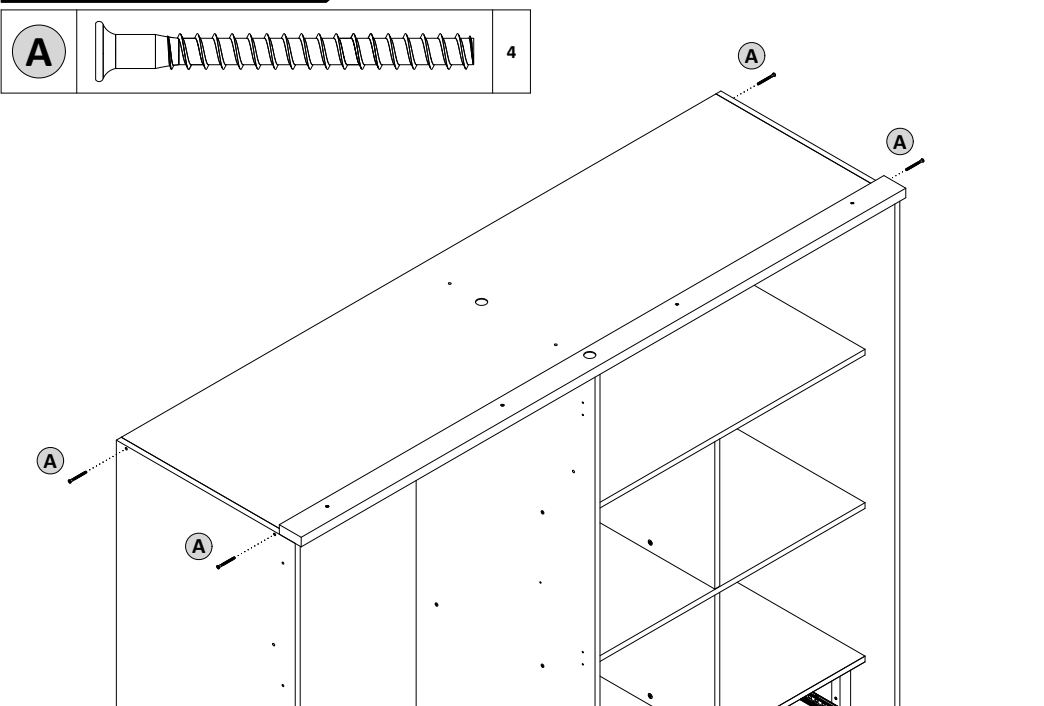

3º PASSO | PASS | PASO

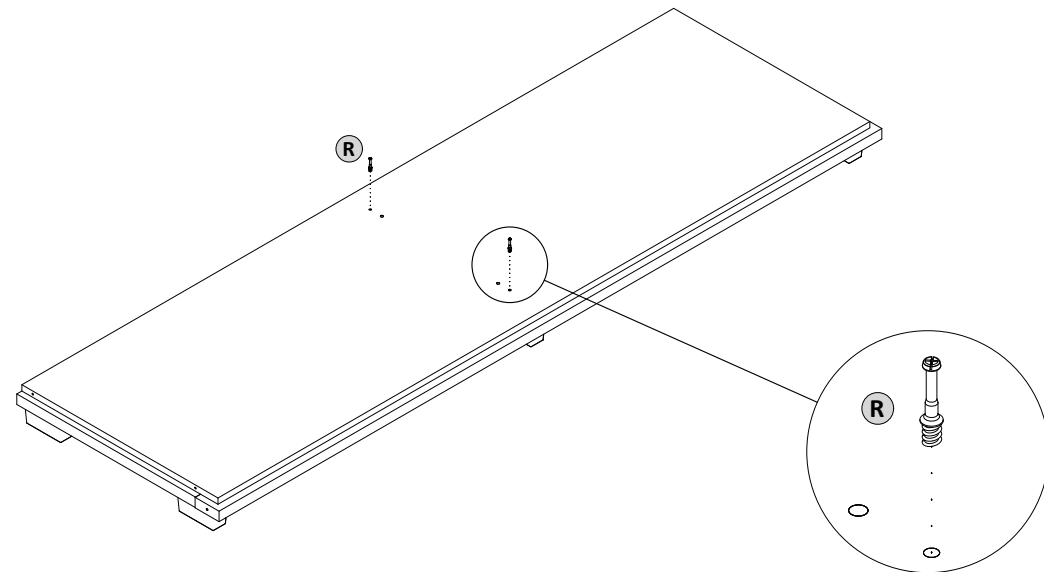
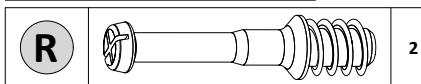

4º PASSO | PASS | PASO

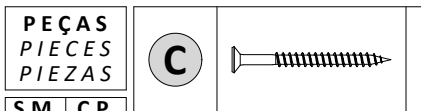

PEÇAS PIECES PIEZAS	
S.M.	C.P.
01	19
02	20

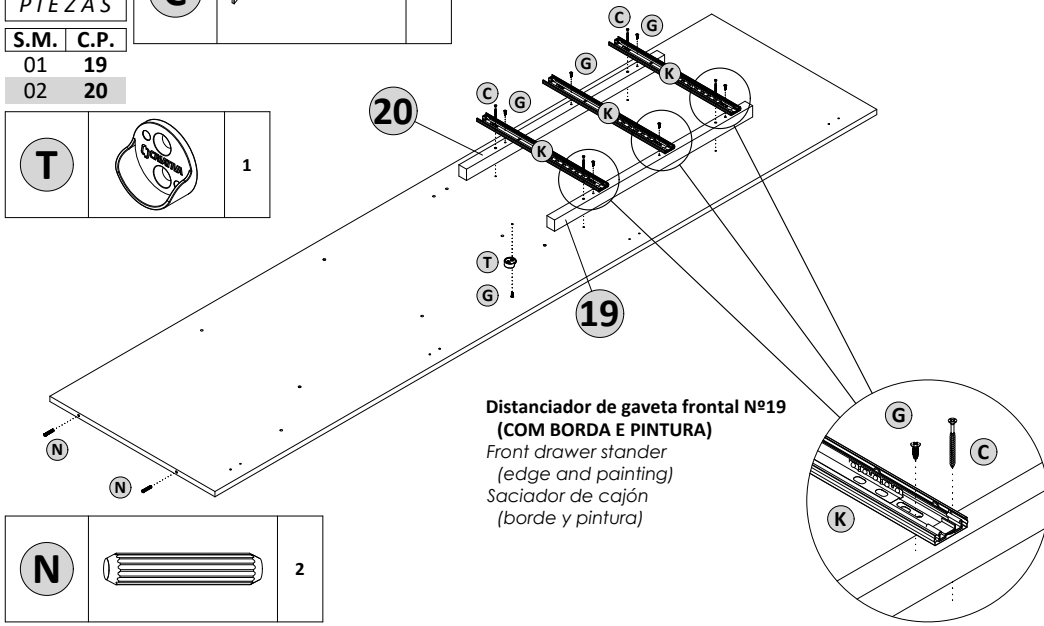
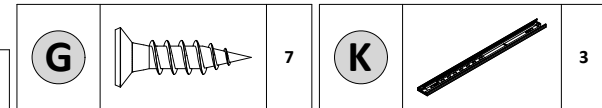
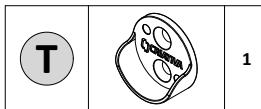

**Distanciador de gaveta frontal Nº19
(COM BORDA E PINTURA)**
Front drawer stander
(edge and painting)
Saciador de cajón
(borde y pintura)

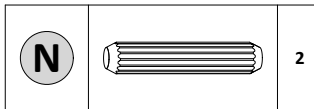

5º PASSO | PASS | PASO

PEÇAS
PIECES
PIEZAS

S.M.	C.P.
01	08
02	04
03	10

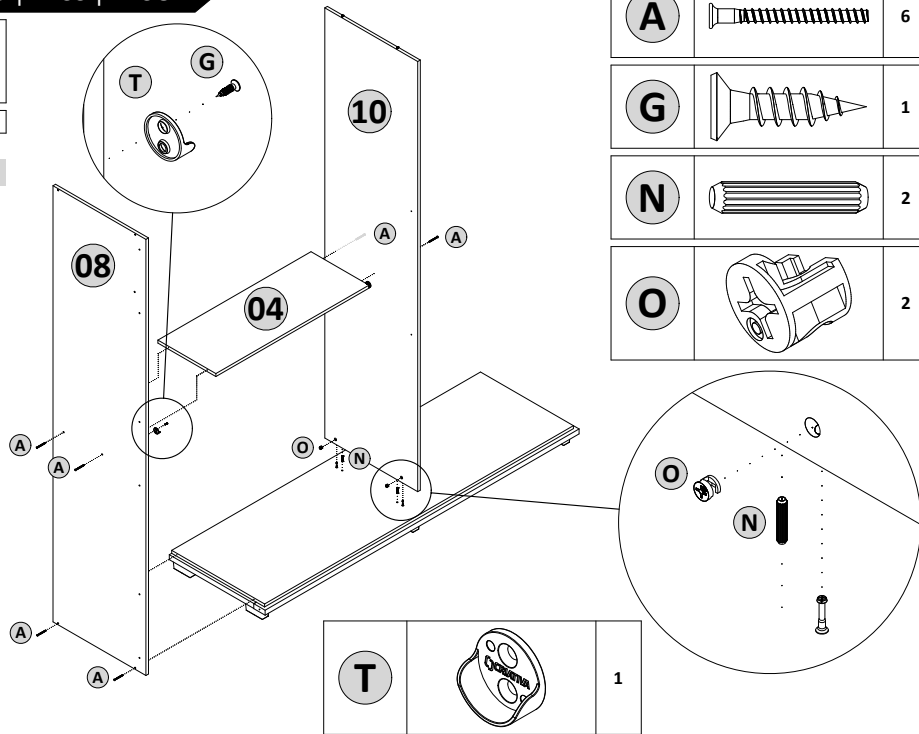

6º PASSO | PASS | PASO

PEÇAS
PIECES
PIEZAS

S.M.	C.P.
01	21
02	22

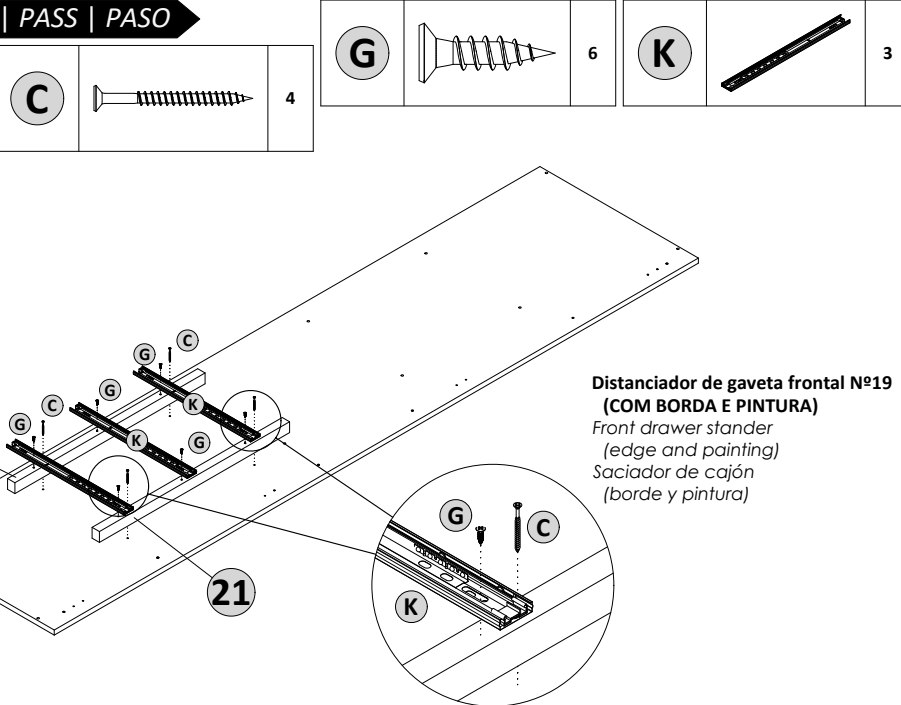

7º PASSO | PASS | PASO

PEÇAS
PIECES
PIEZAS

S.M.	C.P.
01	05
02	12
03	11
04	03
05	11
06	06

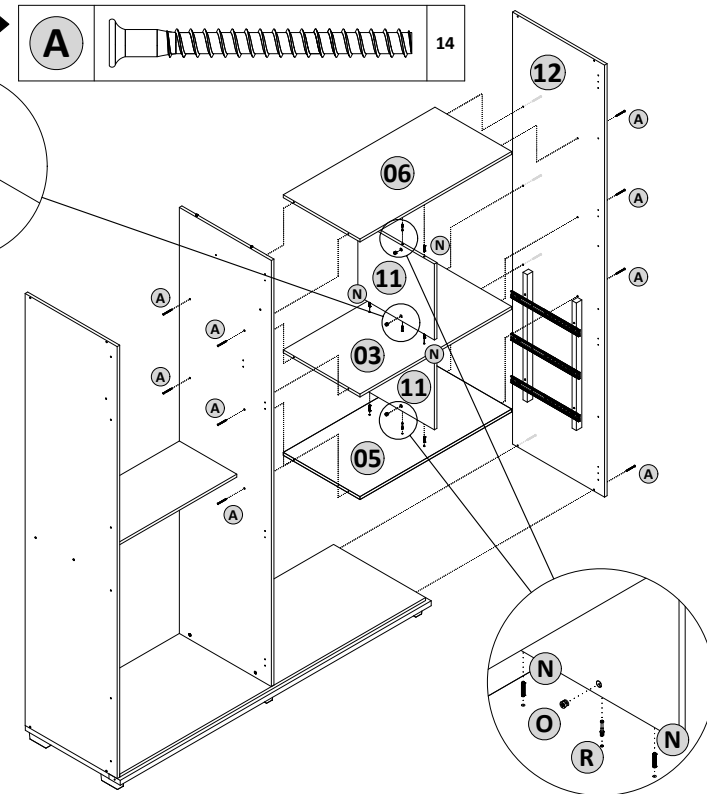
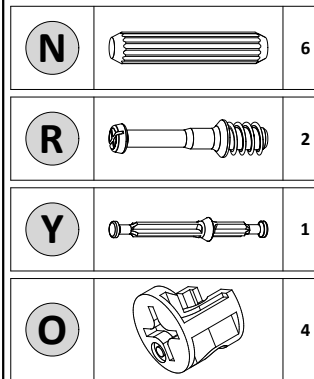

8º PASSO | PASS | PASO

PEÇAS
PIECES
PIEZAS

S.M.	C.P.
01	07
02	19

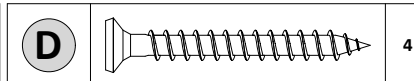

FIXAÇÃO DA MOLDURA NO CHAPÉU
FIXING THE FRAME TO THE UPPER PANEL
FIJACIÓN DEL MARCO AL PANEL SUPERIOR

FIXAR USANDO AS MARCAÇÕES PARA QUE A MOLDURA FIGUE NA POSIÇÃO CORRETA
FIX USING THE MARKINGS SO THAT THE FRAME IS IN THE CORRECT POSITION
FIJAR USANDO LAS MARCAS PARA QUE EL MARCO QUEDE EN LA POSICIÓN CORRECTA

