

HENN

Ind. e Com. de Móveis Henn
Mondai - SC - Brasil

+55 49 3674.3500

@moveishenn
www.henn.com.br

INSTRUÇÕES DE MONTAGEM

INSTRUCCIONES DE MONTAJE
ASSEMBLY INSTRUCTIONS

Cristaleira 02 Portas 02 Gavetas Emily

CE460-131 Cinza

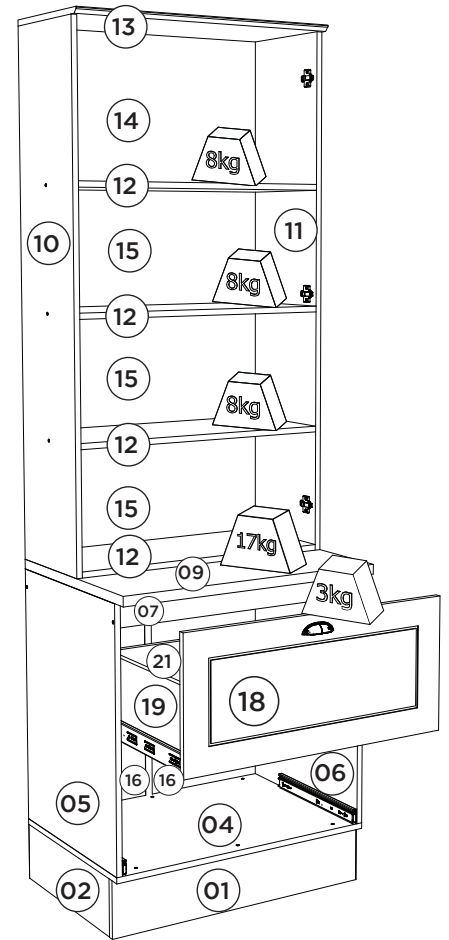
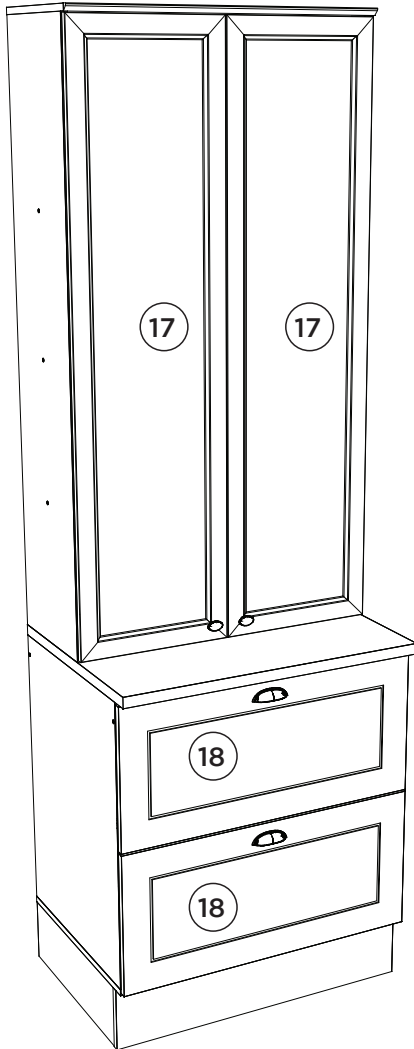

Pesos máximos recomendados com carga distribuída
Peso máximo recomendado con la carga distribuida
Recommended maximum weights with evenly distributed.

Requisitos para montagem Requisitos para la montaje Assembly Requirements

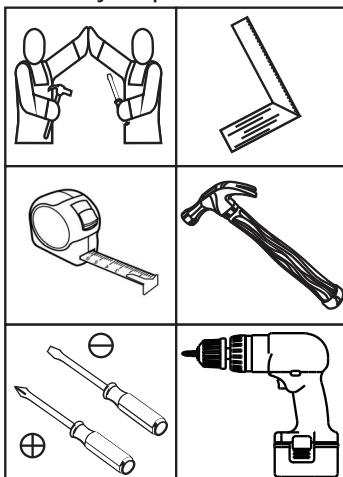

Imagens meramente ilustrativas,
não acompanha o produto.
Imágenes ilustrativas, no incluidas
con el producto.
Illustrative images, not included
with the product.

AVISO

Para limpeza de seu móvel, use uma flanela seca ou umedecida, e não utilize produtos químicos que possam danificar seu produto.

SISTEMA DE MONTAGEM

O sistema de montagem dos produtos, funciona de acordo com a ordem crescente dos números indicados no desenho. Ex: 01, 02, 03, 04... até a conclusão da montagem.

ASSISTÊNCIA TÉCNICA

Para solicitação de Assistência Técnica você consumidor deverá entrar em contato com o Lojista o qual você realizou a compra deste produto e solicitar a assistência técnica das peças avariadas. A garantia abrange todas as peças, partes e componentes que eventualmente venham apresentar defeito de fabricação no prazo de 03 (três) meses, contando a partir da entrega do produto ao consumidor, mediante nota fiscal de compra. Se houver qualquer alteração na estrutura do produto ou ocorrer defeito por negligência do montador/consumidor em relação a instrução de montagem e manuseio, não será fornecido assistência técnica gratuita.

ADVERTENCIA

Para limpieza de su móbil, use una flanela seca o húmeda, y no utilice productos químicos que puedan dañar su producto.

SISTEMA DE MONTAJE

El sistema de montaje de los productos funciona de acuerdo con el orden creciente de los números indicados en el dibujo. Ej.: 01, 02, 03, 04... hasta la conclusión del montaje.

ASISTENCIA TÉCNICA

Para solicitar Asistencia Técnica, el consumidor debe comunicarse con el Comercio que usted realizó la compra de este producto y solicita asistencia técnica para las partes dañadas. La garantía cubre todas las partes, piezas y componentes que eventualmente puedan presentar defecto de fabricación en el plazo de 03 (tres) meses, contados a partir de la entrega del producto al consumidor, mediante factura de compra. Si se produce algún cambio en la estructura del producto o se produce un defecto por negligencia del montador/consumidor en relación con las instrucciones de montaje y manipulación, no se prestará asistencia técnica gratuita.

NOTICE

To clean your furniture, use a dry or wet cloth, and do not use chemicals that may damage your product.

ASSEMBLY SYSTEM

The products' assembly system works according to the increasing order of the indicated numbers. For example: 01, 02, 03, 04 ... to the end of the assembly.

TECHNICAL ASSISTANCE

To request Technical Assistance, the consumer must contact the retailer from whom you purchased this product and request technical assistance for the damaged parts. The warranty covers all parts, parts and components that may eventually present a manufacturing defect within a period of 03 (three) months, counting from the delivery of the product to the consumer, by means of a purchase invoice. If there is any change in the structure of the product or defect occurs due to negligence of the assembler/consumer in relation to the assembly and handling instruction, free technical assistance will not be provided.

1

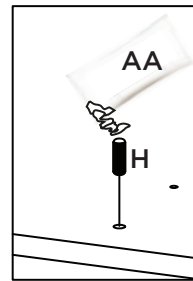
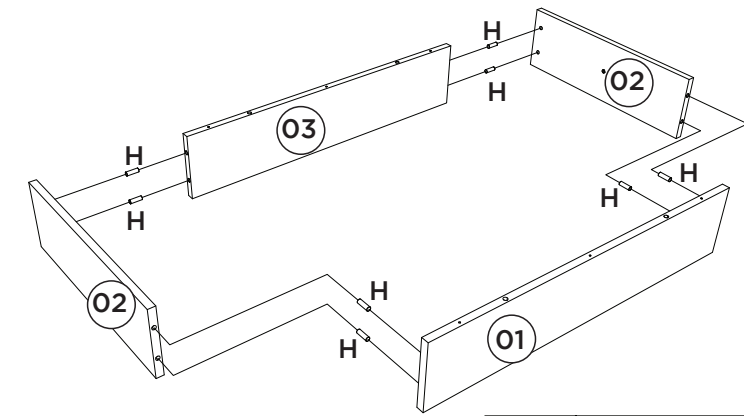

Utilizar o sachê de cola (AA) em todas as cavilhas (H) do produto.

Con el pegamento sobre (AA) en todos los pernos (H) producto.

Use the glue sachet (AA) on all the pegs (H) of the product.

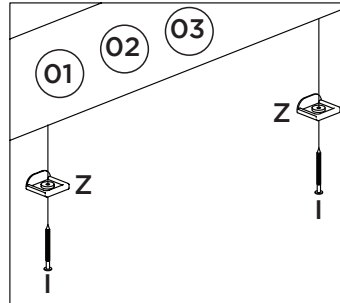
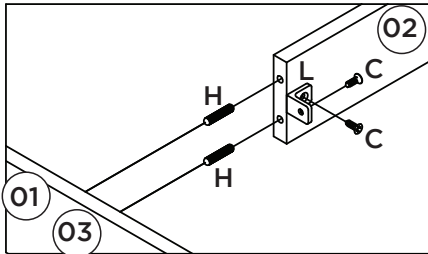

OPCIONAL:

O944-121 Kit Pé Cônico 145mm (vendido separadamente). Caso opte em colocar pé no produto, utilizar as pré-furações que possui na Base e fixá-lo com o Parafuso que consta no Kit.

OPCIONAL:

O944-121 Kit Pie Cónico 145mm (se vende por separado). Si opta por colocar pie en el producto, utilizar las pre-huracuras que tenga en la Base y fijarlo con el Tornillo que consta en el Kit.

OPTIONAL:

O944-121 Tapered Foot Kit 145mm (sold separately). If you choose to put foot in the product, use the pre-drillings in the Base and fix it with the Screw included in the Kit.

2

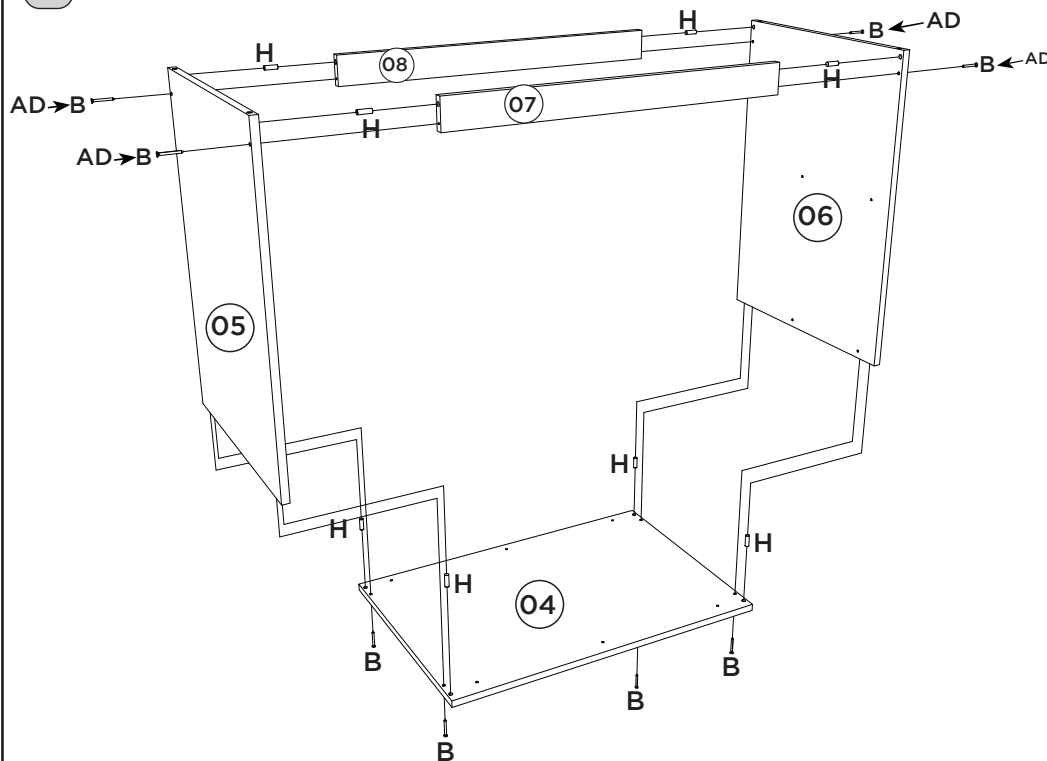

3

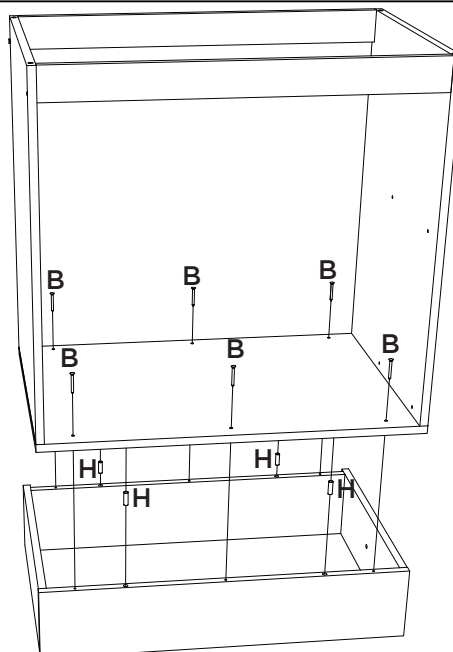

4

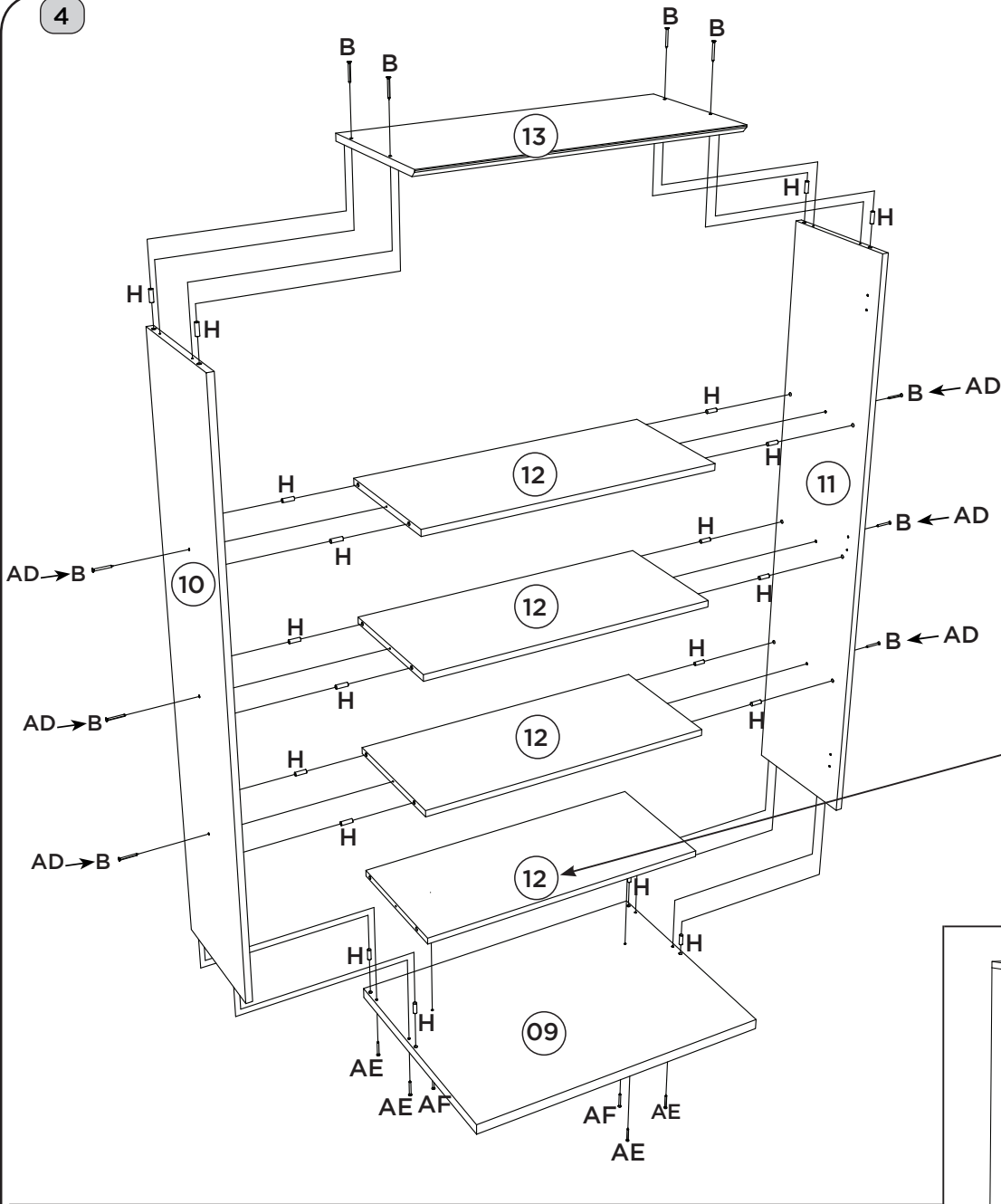

Peça (12) apenas fixada com Parafuso (AF), de baixo para cima.

Pieza (12) sólo fijada con Tornillo (AF), de abajo hacia arriba.

Part (12) only fixed with Screw (AF) from bottom to top.

5

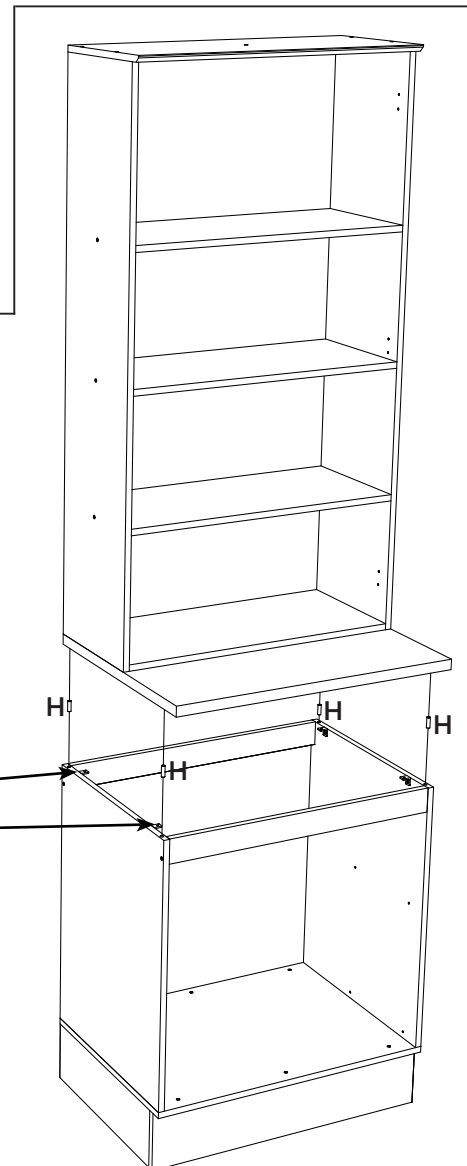
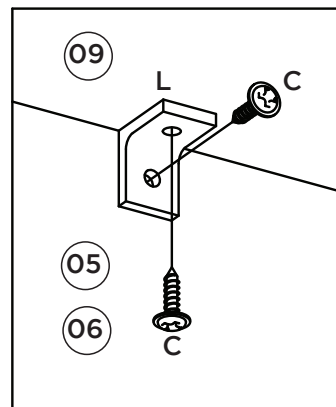

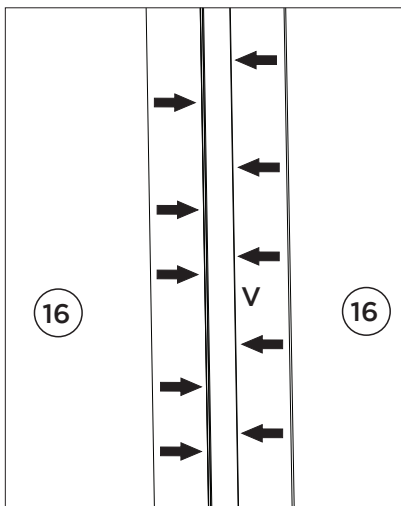
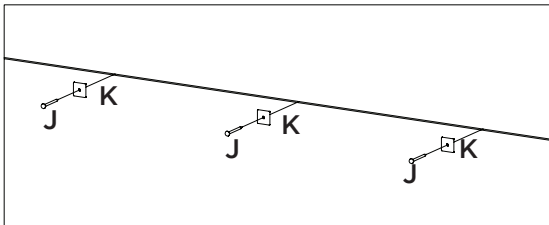
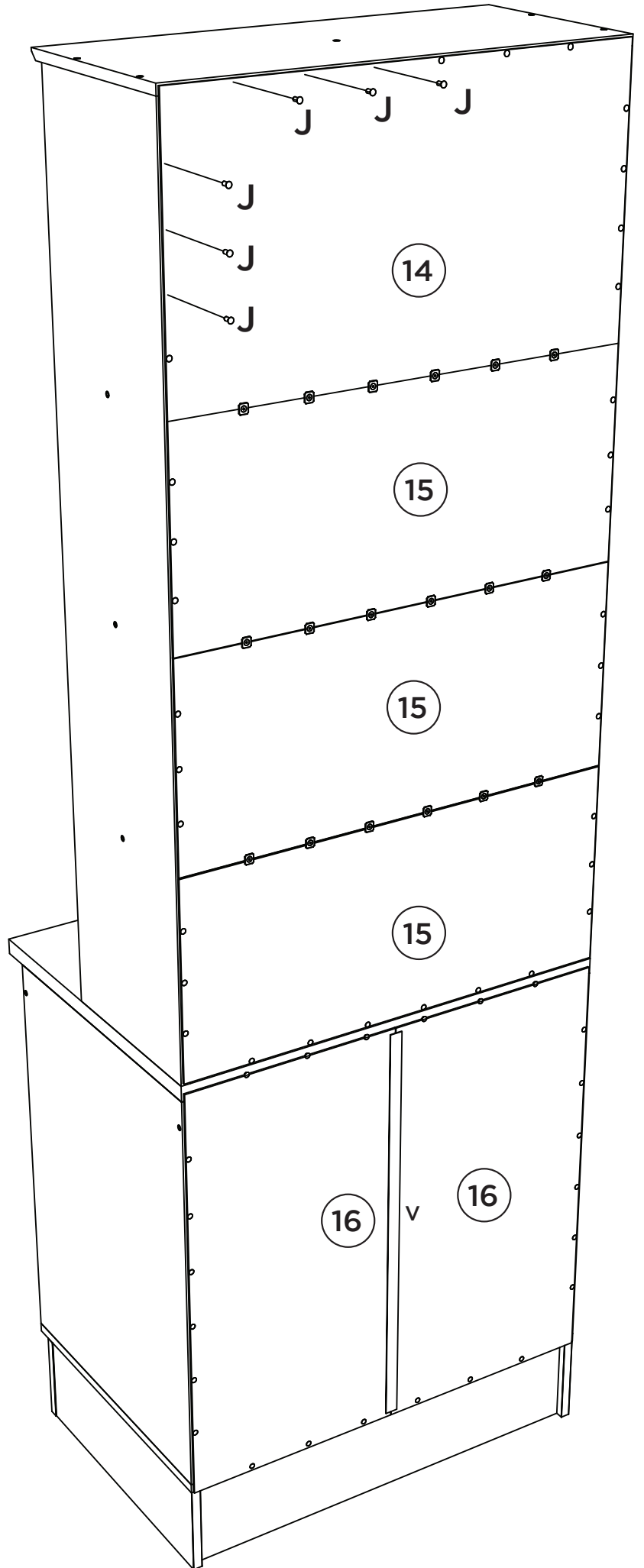

Opção Suspensa

Opción suspendida

Suspended Option

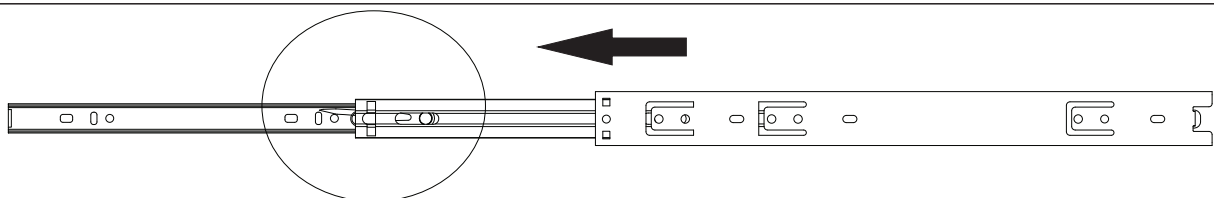
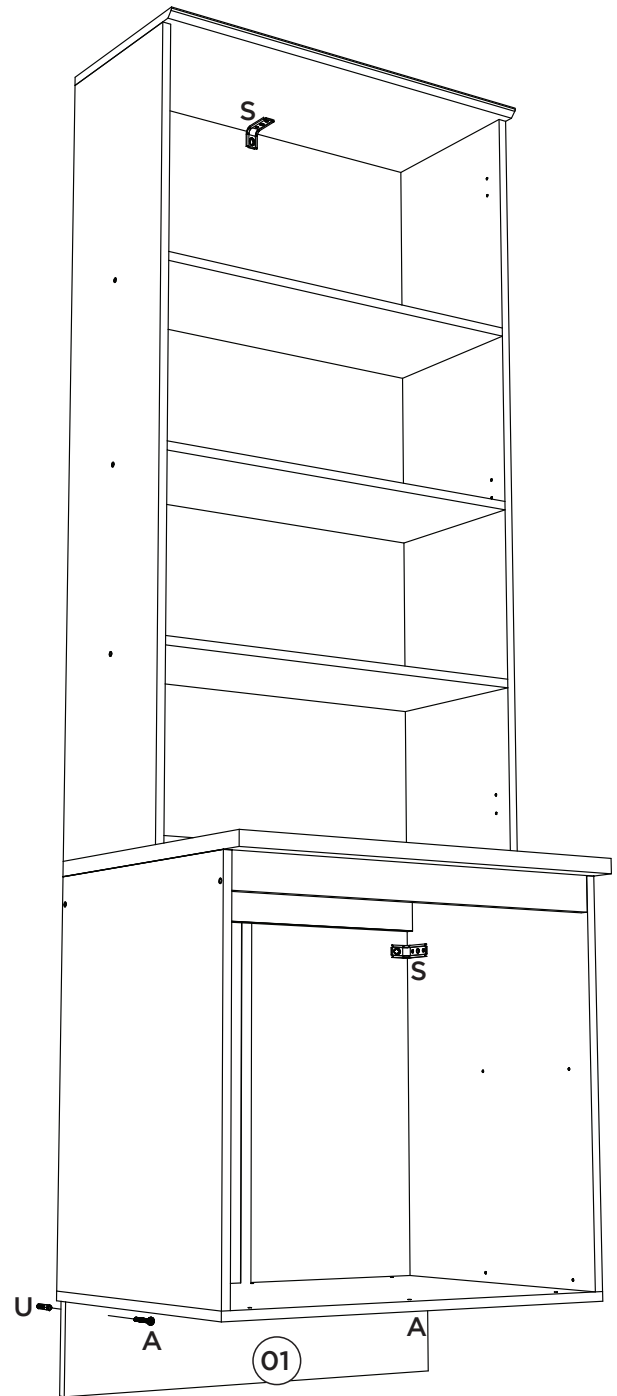
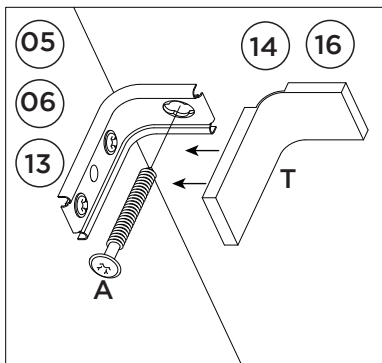
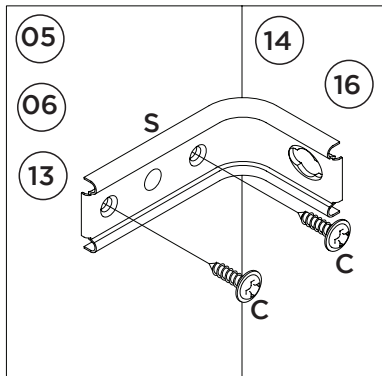
Parede
pared
Wall

Para a desmontagem da corredeira
siga a instrução ao lado.

Para el desmontaje seguimiento de diapositivas
la instrucción siguiente a.

For the dismount of the sliding onem follows
the instruction aside.

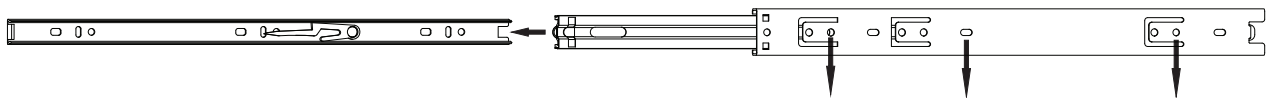
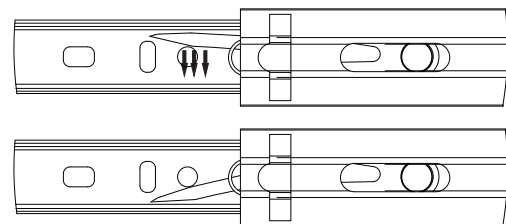

Fixar as corredeiras nessas furações
Fijar las diapositivas de estos agujeros
Fix slides in these drillings

8

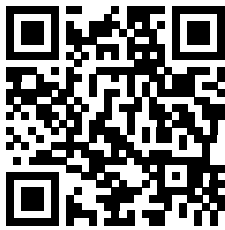

Vídeo: Instalar e regular Dobradiças

Video: Instale y ajuste las bisagras

Video: Install and adjust hinges

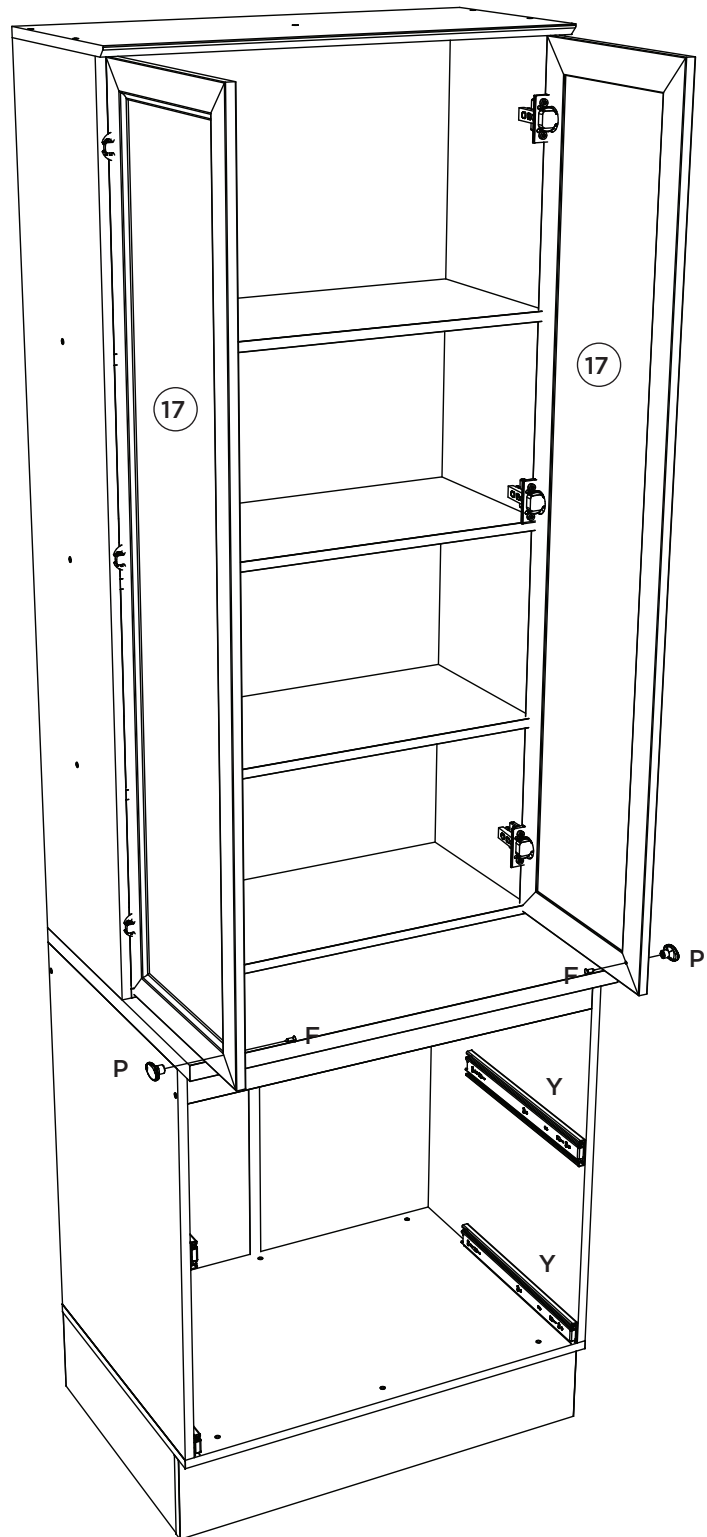
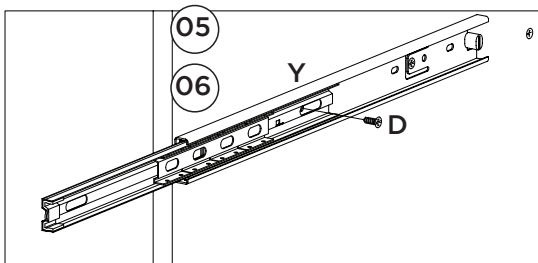
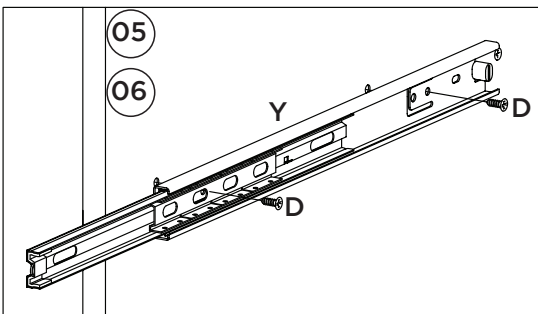
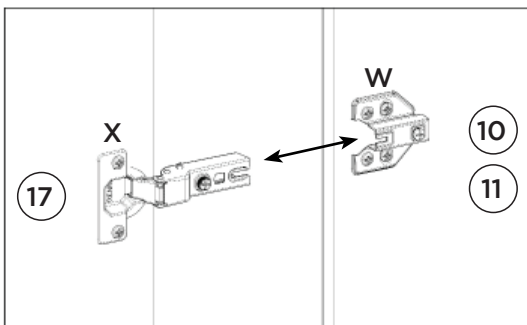
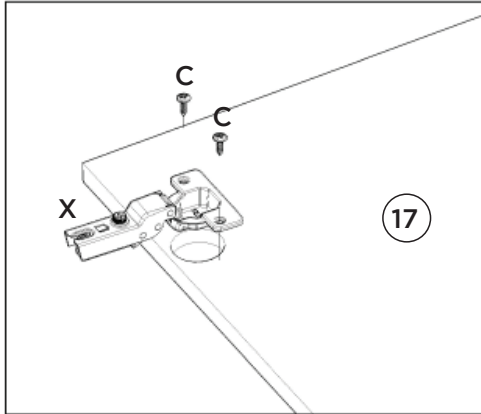
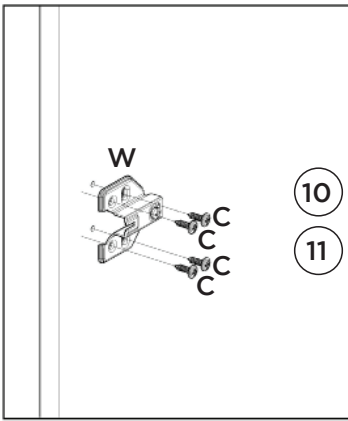

Para colocação dos puxadores, é necessário fazer a furação passante, com Broca de 5mm.

Para la colocación de las asas, es necesario perforar a través, con una broca de 5mm.

To place the handles is necessary to make the through hole, drill 5mm.

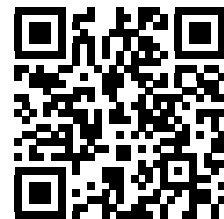
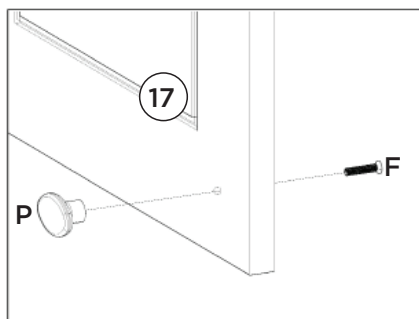

Vídeo: Dicas para fixar a Corrediça

Video: Consejos para arreglar la diapositiva

Video: Tips for Fixing the Slide

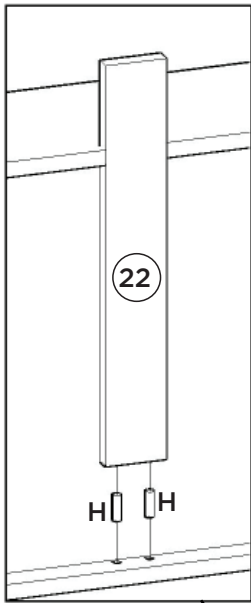
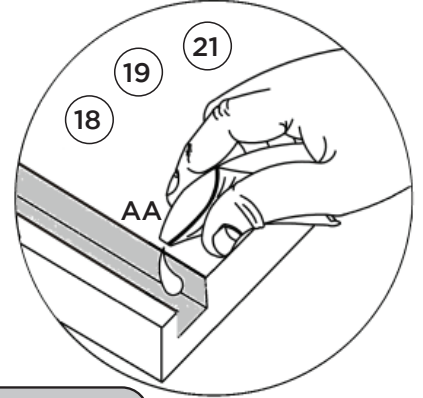
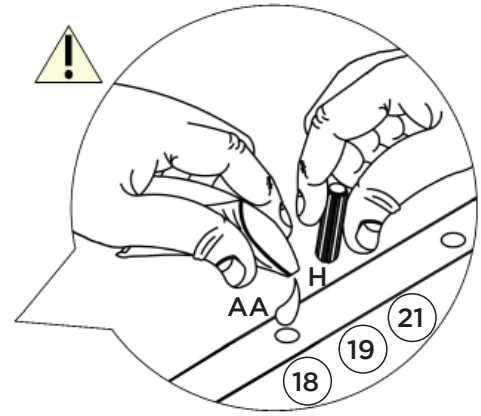
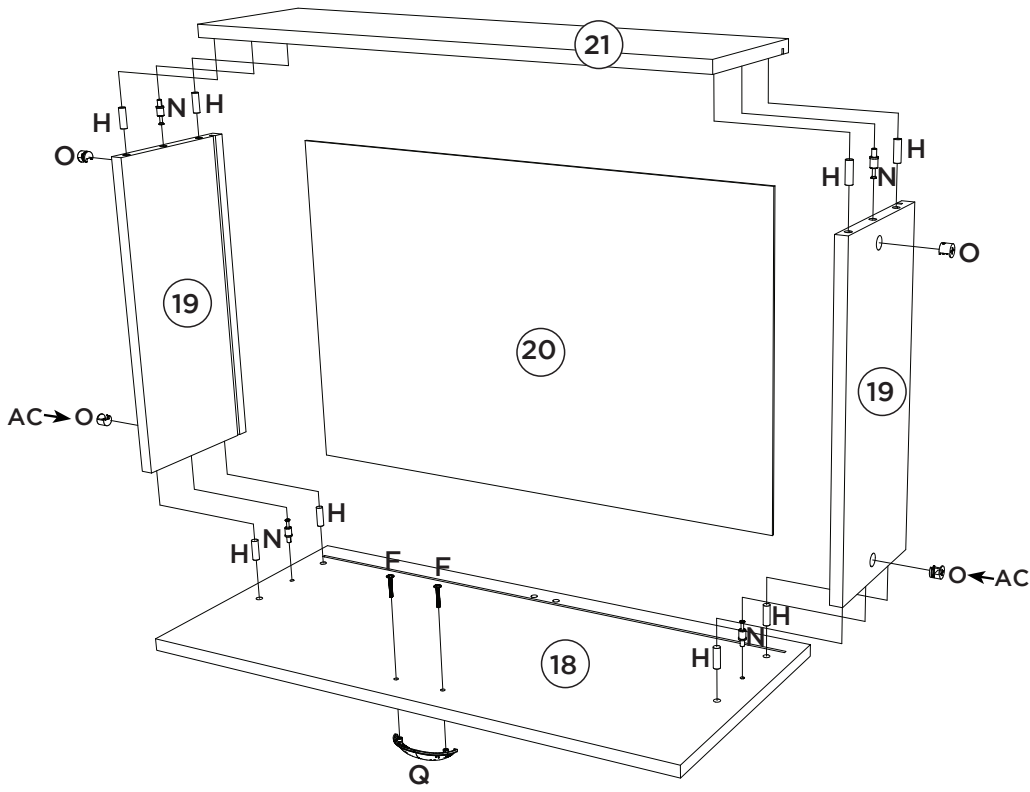



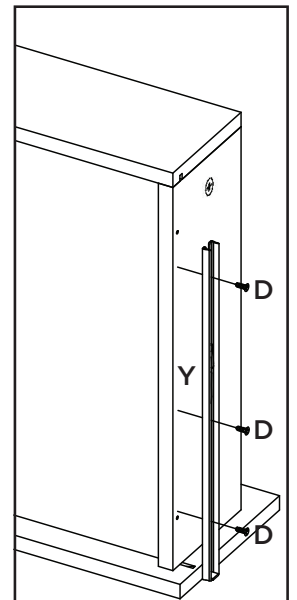
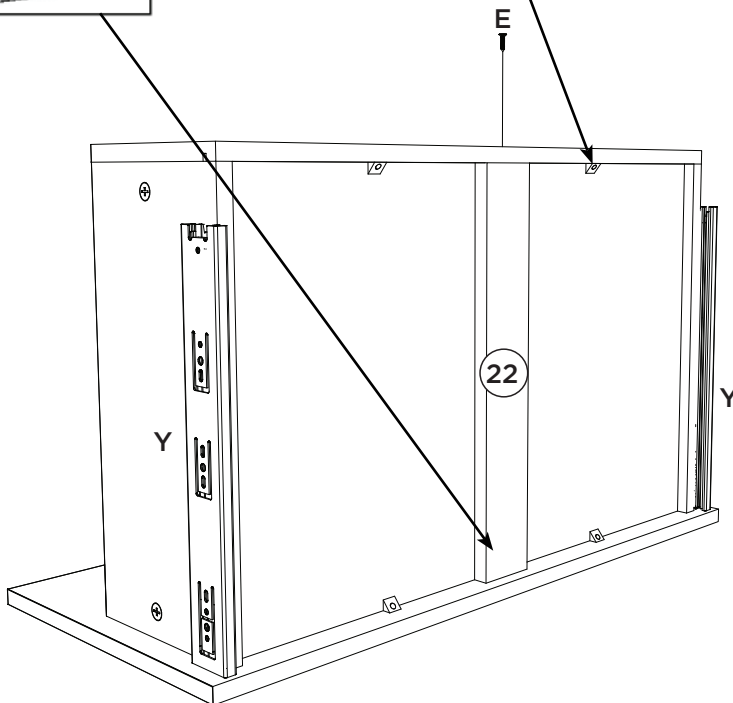
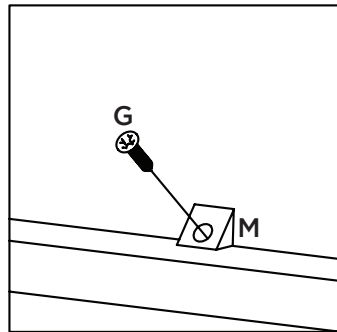











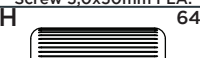
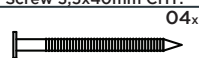
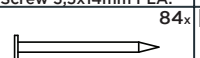
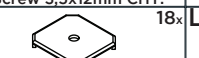

- Vídeo: Dicas para fixar o Minifix
- Video: Consejos para arreglar Minifix
- Video: Tips for Fixing Minifix

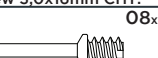

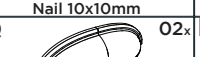
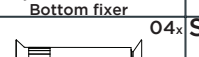
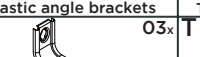
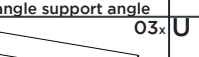
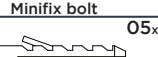
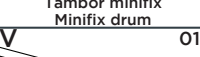
Lista de Peças | Lista de piezas | List of parts

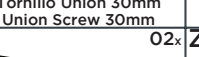
| Item | Caixa Caja Box | Qty Ctd Qty | Descrição Descripción Description | Medidas (mm) Dimensions (mm) Size (measurements) (mm) |
|------|----------------------|-------------------|---|---|
| 01 | 2/2 | 01 | Rodapé Frontal Frente pie de página Front Footer | 715x145x15 |
| 02 | 2/2 | 02 | Rodapé Lateral Pie de página Side Side Footer | 450x145x15 |
| 03 | 2/2 | 01 | Rodapé Traseiro Pie de página trasera Rear Footer | 683x145x15 |
| 04 | 2/2 | 01 | Base Base Base | 715x490x15 |
| 05 | 2/2 | 01 | Lateral Esquerda Inferior Lateral Izquierda Inferior Left Side Lower | 660x490x15 |
| 06 | 2/2 | 01 | Lateral Direita Inferior Lateral Derecha Inferior Right Side Bottom | 660x490x15 |
| 07 | 2/2 | 01 | Travessa frontal Travesaño frontal Front crossbar | 684x60x15 |
| 08 | 2/2 | 01 | Travessa traseira Travesaño trasero Rear bumper | 684x60x15 |
| 09 | 2/2 | 01 | Tampo Central 25mm Tapa Central 25mm Central Surface 25mm | 715x533x25 |
| 10 | 1/2 | 01 | Lateral Esquerda Superior Lateral Izquierda Superior Upper Left Side | 1345x295x15 |
| 11 | 1/2 | 01 | Lateral Direita Superior Lateral Derecha Superior Right Side Superior | 1345x295x15 |
| 12 | 2/2 | 04 | Prateleira Estante Shelf | 684x295x15 |
| 13 | 2/2 | 01 | Tampo Tapa Top | 715x322x15 |
| 14 | 2/2 | 01 | Fundo central Fondo central Central fund | 708x417x3 |
| 15 | 2/2 | 03 | Fundo Fondo Bottom | 708x311x3 |
| 16 | 1/2 | 02 | Fundo Cru Fondo Crudo Raw Background | 687x353x3 |
| 17 | 1/2 | 02 | Porta Vidro Puerta de cristal Glass Door | 1339x354x15 |
| 18 | 2/2 | 02 | Frente de gaveta Frente de cajón Front of drawer | 711x330x15 |
| 19 | 2/2 | 04 | Lado de Gaveta Lado del cajón Drawer Side | 400x180x15 |
| 20 | 2/2 | 02 | Fundo de gaveta Fondo de cajón Bottom of drawer | 640x411x3 |
| 21 | 2/2 | 02 | Ripa de trás Malla detrás Rear lath | 659x180x15 |
| 22 | 2/2 | 02 | Ripa Estrutural Gaveta Ripa Estructural Cajón Drawer Structural Clamp | 400x60x15 |

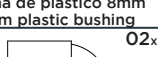
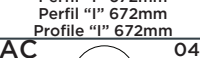
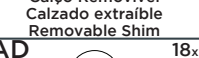
Ferragens | Herrajes | Hardware

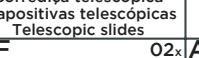
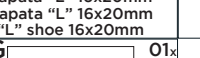
| | | | | | | |
|---|--|--|---|---|---|--|
| A 05x  Parafuso 5,0x50mm FLA. Tornillo 5,0x50mm FLA. Screw 5,0x50mm FLA. | B 24x  Parafuso 3,5x40mm CHT. Tornillo 3,5x40mm CHT. Screw 3,5x40mm CHT. | C 58x  Parafuso 3,5x14mm FLA. Tornillo 3,5x14mm FLA. Screw 3,5x14mm FLA. | D 24x  Parafuso 3,5x12mm CHT. Tornillo 3,5x12mm CHT. Screw 3,5x12mm CHT. | E 02x  Parafuso 3,0x30mm CHT. Tornillo 3,0x30mm CHT. Screw 3,0x30mm CHT. | F 06x  Parafuso M4x20mm CHT. ZB Tornillo M4x20mm CHT. ZB Screw M4x20mm CHT. ZB | G 08x  Parafuso 3,0x16mm CHT. Tornillo 3,0x16mm CHT. Screw 3,0x16mm CHT. |
| H 64x  Cavilha 8x25mm Cinta 8x25mm Dowel 8x25mm | I 04x  Prego 12x12mm Anelado Clavo 12x12mm Anillado Ringed Nails 12x12mm | J 84x  Prego 10x10mm Clavo 10x10mm Nail 10x10mm | K 18x  Fixador de fundos Fijador de fondos Bottom fixer | L 08x  Cantoneira plástica Cantoneira plástica Plastic angle brackets | M 08x  Cantoneira suporte triangular Cantoneira soporte triangular Triangle support angle | N 08x  Parafuso minifix Tornillo minifix Minifix bolt |
| O 08x  Tambor minifix Tambor minifix Minifix drum | P 02x  Puxador Pontual PZ14 Oval Tirador Puntual PZ14 Oval PZ14 Oval Point Knob | Q 02x  Puxador Concha Tirador Concha Shell Handle | R 04x  Parafuso União 30mm Tornillo Unión 30mm Union Screw 30mm | S 03x  Suporte de fixação Soporte de fijación Mounting bracket | T 03x  Proteção para cantoneira Ángulo de protección Protection angle | U 05x  Buchta plástica 8mm Buchta de plástico 8mm 8mm plastic bushing |
| V 01x  Perfil "I" 672mm Perfil "I" 672mm Profile "I" 672mm | W 06x  Calço Removível Calzado extraíble Removable Shim | X 06x  Dobradica SlideOn Balsa Amortecedor 35mm Bisagra SlideOn Baja Amortiguador 35mm Low SlideOn Hinge 35mm Shock Absorber | Y 02x  Corrediza telescópica Diapositivas telescópicas Telescopic slides | Z 04x  Sapata "L" 16x20mm Zapata "L" 16x20mm "L" shoe 16x20mm | AA 01x  Sachê de cola Bolsa de pegamento Glue bag | AB 02x  Giz de correção Tiza de corrección Chalk of correction |
| AC 04x  Adesivo tampa parafuso 17mm Adhesivo tapón de tornillo 17mm Bolt cover adhesive 17mm | AD 18x  Adesivo tampa parafuso 10mm Adhesivo tapón de tornillo 10mm Bolt cover adhesive 10mm | AE 04x  Parafuso 4,5x50mm CHT. Tornillo 4,5x50mm CHT. Screw 4,5x50mm CHT. | AF 02x  Parafuso 4,0x35mm CHT. Tornillo 4,0x35mm CHT. Screw 4,0x35mm CHT. | AG 01x  Etiqueta resinada Henn Etiqueta resinada Henn Henn resin label | | |



O parafuso (R) deve ser usada somente quando este módulo for acoplado a outro módulo componível Henn.

RECOMENDAÇÃO

Para fixar o móvel na parede usar o suporte de fixação (S), o parafuso 3,5x14mm FLA (C), a Bucha 8mm (U) e o parafuso 5,0x50mm FLA (A).



El tornillo (R) se debe utilizar sólo cuando el módulo está conectado a otro módulo componible Henn.

RECOMENDACIÓN

Para conectar el móvil a la pared con el soporte (S), tornillo 3,5 x14mm FLA (C), el casquillo de 8 mm (U) y el 5,0 x50mm tornillo FLA (A).



The screw (R) should be used only when this module is attached to another Henn modular module.

RECOMMENDATION

To fix the furniture to the wall use the mounting bracket (S), the 3.5x14mm FLA (C) screw, the 8mm bushing (U) and the 5.0x50mm FLA (A).