

RACK CAVA SLIM 1360

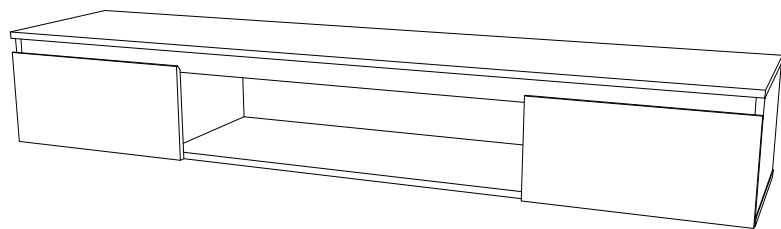

Composição do Produto

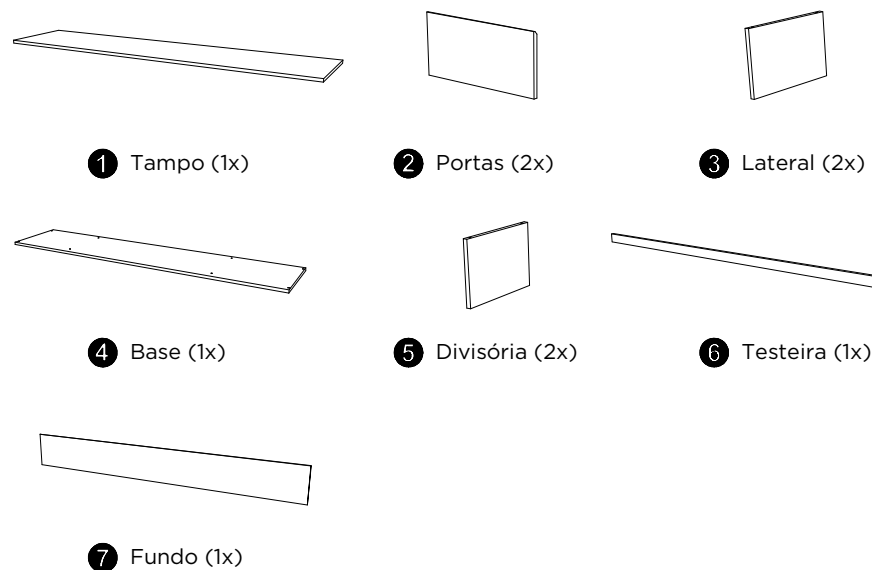

Componentes de Montagem



A- Parafuso phillips chipboard 3x30 (4x)



B- Cavilha 6x30 (16x)



C- Cantoneira 2 furos (12x)



D- Tapa furo adesivo (4x)



E- Prego 10x10 (12x)



F- Dobradiça (4x)



G- Parafuso phillips chipboard 4x12 (46x)

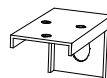

H- Suporte aéreo fixação 27x54 (2x)



I- Parafuso phillips flangeado 6x60 (2x)



J- Bucha de parede (2x)

Utilizar a régua abaixo para medir os componentes.



Atenção

- 1- Leia atentamente toda a instrução antes de iniciar a montagem.
- 2- A montagem do produto deverá ser feita em uma superfície limpa e plana. Aconselhamos utilizar a própria embalagem para forrar o chão a fim de não danificar o produto.
- 3- Reservar área livre para montagem do produto.



Pessoas necessárias para montar o produto



Tempo de montagem aproximado



Grau de dificuldade



Não utilizar químicos ou abrasivos na limpeza, evitar batidas e contato com objetos cortantes



Pano umedecido com água seguido de pano seco



Capacidade máxima suportável, distribuída uniformemente

1 Montagem

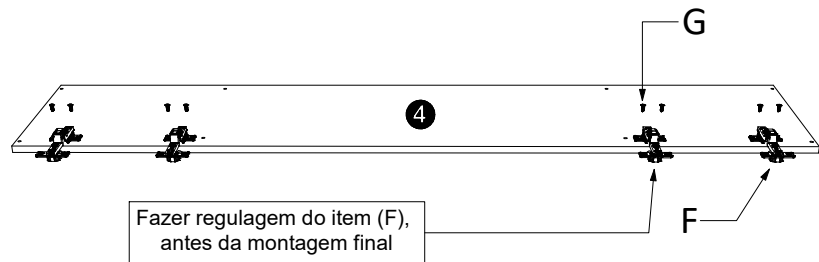

2

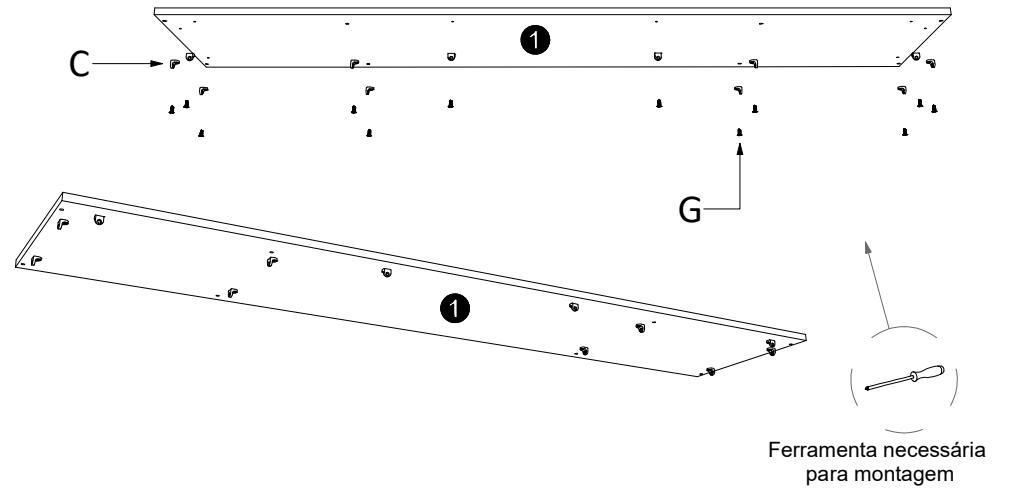

3

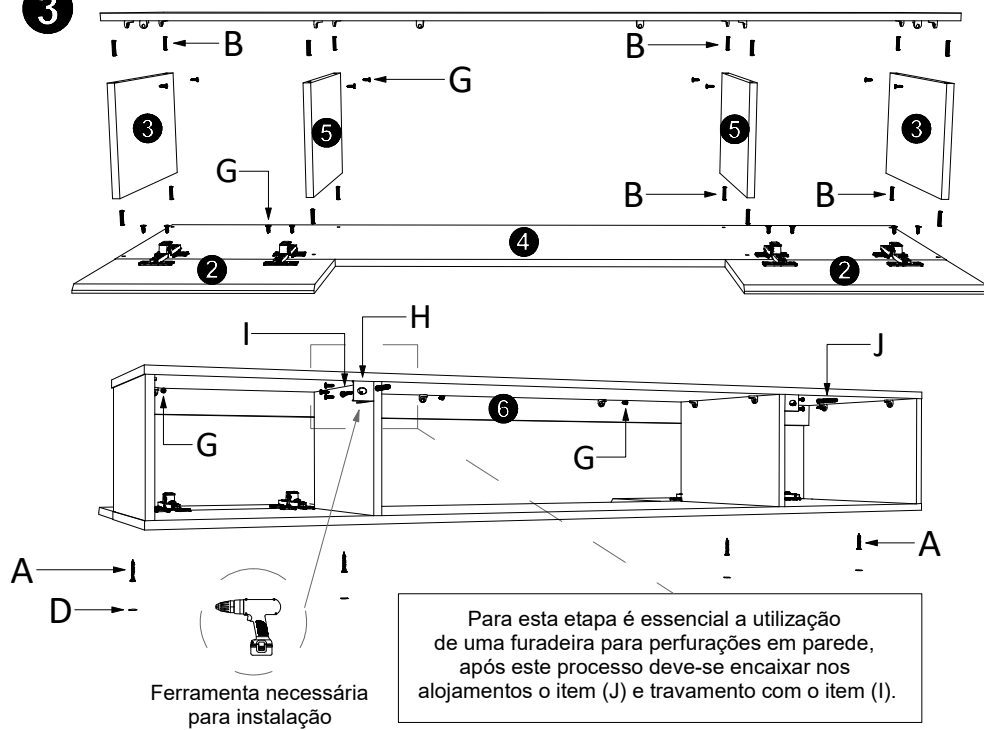

4

