

Item	Caixa Caja Box	Qty Ctd Qty	Descrição Descripción Description	Medidas (mm) Dimensions (mm) Size (measurements) (mm)
01	2/2	01	Rodapé Frontal Frente pie de página Front Footer	715x145x15
02	2/2	02	Rodapé Lateral Pie de página Side Side Footer	450x145x15
03	2/2	01	Rodapé Traseiro Pie de página trasera Rear Footer	683x145x15
04	2/2	01	Base Base Base	715x490x15
05	2/2	01	Lateral Esquerda Inferior Lateral Izquierda Inferior Left Side Lower	660x490x15
06	2/2	01	Lateral Direita Inferior Lateral Derecha Inferior Right Side Bottom	660x490x15
07	2/2	01	Travessa frontal Travesaño frontal Front crossbar	684x60x15
08	2/2	01	Travessa traseira Travesaño trasero Rear bumper	684x60x15
09	2/2	01	Tampo Central 25mm Tapa Central 25mm Central Surface 25mm	715x533x25
10	1/2	01	Lateral Esquerda Superior Lateral Izquierda Superior Upper Left Side	1345x295x15
11	1/2	01	Lateral Direita Superior Lateral Derecha Superior Right Side Superior	1345x295x15
12	2/2	04	Prateleira Estante Shelf	684x295x15
13	2/2	01	Tampo Tapa Top	715x322x15
14	2/2	01	Fundo central Fondo central Central fund	708x417x3
15	2/2	03	Fundo Fondo Bottom	708x311x3
16	1/2	02	Fundo Cru Fondo Crudo Raw Background	687x353x3
17	1/2	02	Porta Vidro Puerta de cristal Glass Door	1339x354x15
18	2/2	02	Frente de gaveta Frente de cajón Front of drawer	711x330x15
19	2/2	04	Lado de Gaveta Lado del cajón Drawer Side	400x180x15
20	2/2	02	Fundo de gaveta Fondo de cajón Bottom of drawer	640x411x3
21	2/2	02	Ripa de trás Malla detrás Rear lath	659x180x15
22	2/2	02	Ripa Estrutural Gaveta Ripa Estructural Cajón Drawer Structural Clamp	400x60x15

HENN

Ind. e Com. de Móveis Henn
Mondai - SC - Brasil

+55 49 3674.3500

@moveishenn
www.henn.com.br

INSTRUÇÕES DE MONTAGEM

INSTRUCCIONES DE MONTAJE
ASSEMBLY INSTRUCTIONS

**Cristaleira 02 Portas 02 Gavetas Americana |
Cristalera 02 Puertas 02 Cajones Americana | 2 Doors and 2 Drawers American Display Cabinet
C357-05 Branco HP**

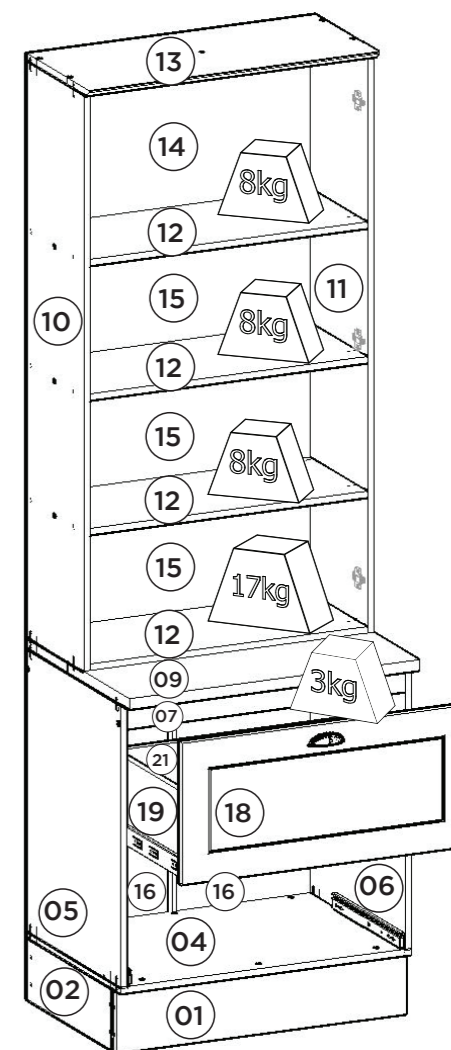
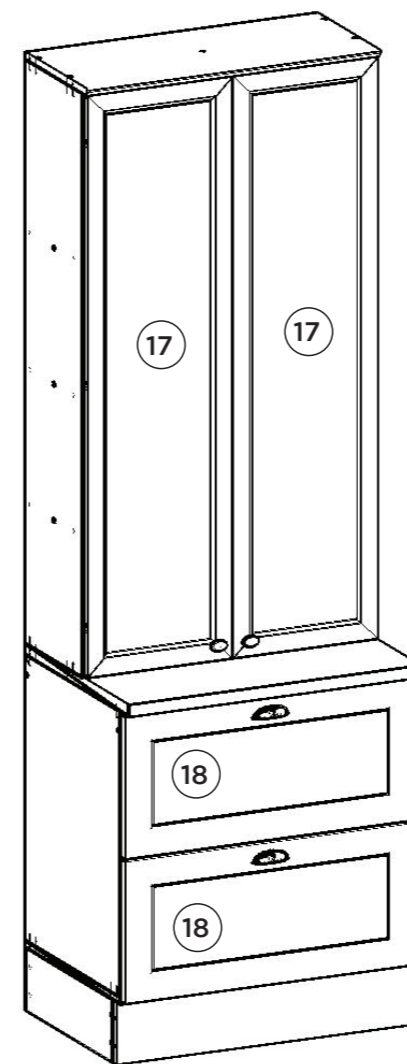

Pesos máximos recomendados com carga distribuída
Peso máximo recomendado con la carga distribuida
Recommended maximum weights with evenly distributed.

Ferragens | Herrajes | Hardware

A 05x Parafuso 5,0x50mm FLA. Tornillo 5,0x50mm FLA. Screw 5,0x50mm FLA.	B 24x Parafuso 3,5x40mm CHT. Tornillo 3,5x40mm CHT. Screw 3,5x40mm CHT.	C 58x Parafuso 3,5x14mm FLA. Tornillo 3,5x14mm FLA. Screw 3,5x14mm FLA.	D 24x Parafuso 3,5x12mm CHT. Tornillo 3,5x12mm CHT. Screw 3,5x12mm CHT.	E 02x Parafuso 3,0x30mm CHT. Tornillo 3,0x30mm CHT. Screw 3,0x30mm CHT.	F 06x Parafuso M4x20mm CHT. ZB Tornillo M4x20mm CHT. ZB Screw M4x20mm CHT. ZB	G 08x Parafuso 3,0x16mm CHT. Tornillo 3,0x16mm CHT. Screw 3,0x16mm CHT.
H 64x Cavilha 8x25mm Cinta 8x25mm Dowel 8x25mm	I 04x Prego 12x12mm Anelado Clavo 12x12mm Anillado Ringed Nails 12x12mm	J 84x Prego 10x10mm Clavo 10x10mm Nail 10x10mm	K 18x Fixador de fundos Fijador de fondos Bottom fixer	L 08x Cantoneira plástica Cantoneira plástica Plastic angle brackets	M 08x Cantoneira suporte triangular Cantoneira soporte triangular Triangle support angle	N 08x Parafuso minifix Tornillo minifix Minifix bolt
O 08x Tambor minifix Tambor minifix Minifix drum	P 02x Puxador Pontual PZ14 Oval Tirador Pontual PZ14 Oval Point Knob	Q 02x Puxador Concha Tirador Concha Shell Handle	R 04x Parafuso União 30mm Tornillo Unión 30mm Union Screw 30mm	S 03x Suporte de fixação Soporte de fijación Mounting bracket	T 03x Proteção para cantoneira Ángulo de protección Protection angle	U 05x Buchas plásticas 8mm Bucha de plástico 8mm 8mm plastic bushing
V 01x Perfil "I" 672mm Perfil "I" 672mm Profile "I" 672mm	W 06x Calço Removível Calzado extraíble Removable Shim	X 06x Dobradora SlideOn Baja Amortecedor 35mm Bisagra SlideOn Baja Amortiguador 35mm Low SlideOn Hinge 35mm Shock Absorber	Y 02x Corrediça telescópica Diapositivas telescópicas Telescopic slides	Z 04x Sapata "L" 16x20mm Zapata "L" 16x20mm "L" shoe 16x20mm	AA 01x Sachê de cola Bolsa de pegamento Glue bag	AB 02x Giz de correção Tiza de corrección Chalk of correction
AC 04x Adesivo tapa parafuso 17mm Adhesivo tapón de tornillo 17mm Bolt cover adhesive 17mm	AD 18x Adesivo tapa parafuso 10mm Adhesivo tapón de tornillo 10mm Bolt cover adhesive 10mm	AE 04x Parafuso 4,5x50mm CHT. Tornillo 4,5x50mm CHT. Screw 4,5x50mm CHT.	AF 02x Parafuso 4,0x35mm CHT. Tornillo 4,0x35mm CHT. Screw 4,0x35mm CHT.	AG 01x Etiqueta resinada Henn Etiqueta resinada Henn Henn resin label		

O parafuso (R) deve ser usada somente quando este módulo for acoplado a outro módulo componível Henn.

El tornillo (R) se debe utilizar sólo cuando el módulo está conectado a otro módulo componible Henn.

The screw (R) should be used only when this module is attached to another Henn modular module.

RECOMENDAÇÃO
Para fixar o móvel na parede usar o suporte de fixação (S), o parafuso 3,5x14mm FLA (C), a Bucha 8mm (U) e o parafuso 5,0x50mm FLA (A).

RECOMENDACIÓN
Para conectar el móvil a la pared con el soporte (S), tornillo 3,5 x14mm FLA (C), el casquillo de 8 mm (U) y el 5,0 x50mm tornillo FLA (A).

RECOMMENDATION
To fix the furniture to the wall use the mounting bracket (S), the 3.5x14mm FLA (C) screw, the 8mm bushing (U) and the 5.0x50mm FLA (A).

**Requisitos para montagem
Requisitor para la montaje
Assembly Requirements**

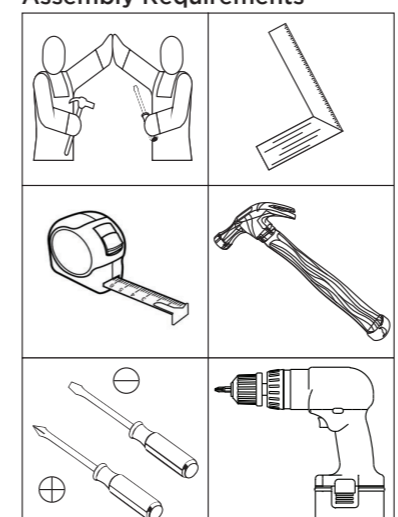

Imagens meramente ilustrativas
Imágenes meramente ilustrativas
Images for illustration only

AVISO
Para limpeza de seu móvel, use uma flanela seca ou umedecida, e não utilize produtos químicos que possam danificar seu produto.

SISTEMA DE MONTAGEM
O sistema de montagem dos produtos, funciona de acordo com a ordem crescente dos números indicados no desenho. Ex: 01, 02, 03, 04... até a conclusão da montagem.

ADVERTENCIA
Para limpieza de su móvil, use una franela seca o húmeda, y no utilice productos químicos que puedan dañar su producto.

SISTEMA DE MONTAJE
El sistema de montaje de los productos funciona de acuerdo con el orden creciente de los números indicados en el dibujo. Ej.: 01, 02, 03, 04... hasta la conclusión del montaje.

NOTICE
To clean your furniture, use a dry or wet cloth, and do not use chemicals that may damage your product.

ASSEMBLY SYSTEM
The products' assembly system works according to the increasing order of the indicated numbers. For example: 01, 02, 03, 04 ... to the end of the assembly.

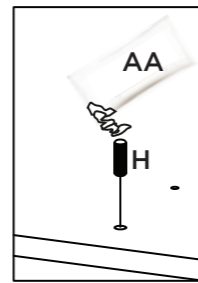
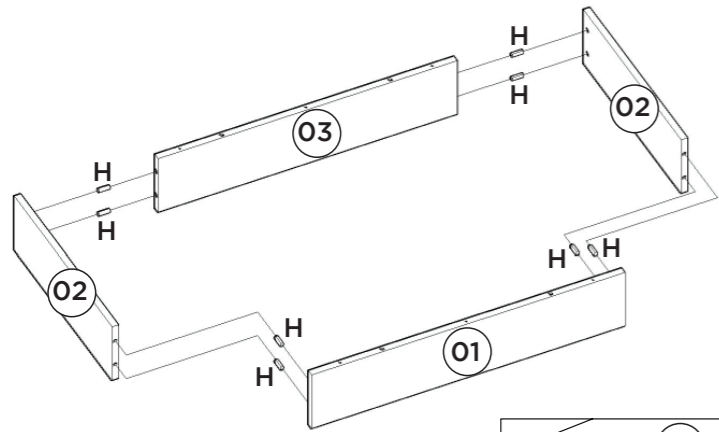

Utilizar o sachê de cola (AA) em todas as cavilhas (H) do produto.

Con el pegamento sobre (AA) en todos los pernos (H) producto.

Use the glue sachet (AA) on all the pegs (H) of the product.

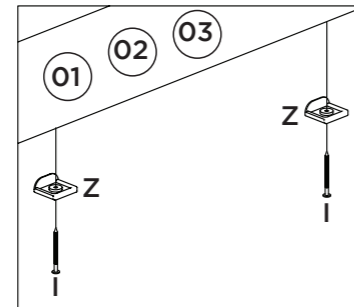
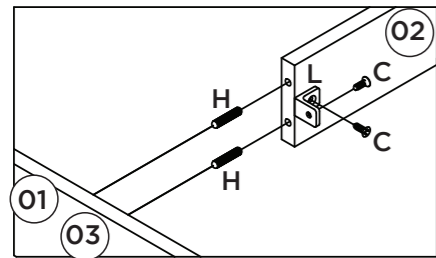

OPCIONAL:

O944-121 Kit Pé Cônico 145mm (vendido separadamente). Caso opte em colocar pé no produto, utilizar as pré-furações que possui na Base e fixá-lo com o Parafuso que consta no Kit.

OPCIONAL:

O944-121 Kit Pie Cónico 145mm (se vende por separado). Si opta por colocar pie en el producto, utilizar las pre-huracuras que tenga en la Base y fijarlo con el Tornillo que consta en el Kit.

OPTIONAL:

O944-121 Tapered Foot Kit 145mm (sold separately). If you choose to put foot in the product, use the pre-drillings in the Base and fix it with the Screw included in the Kit.

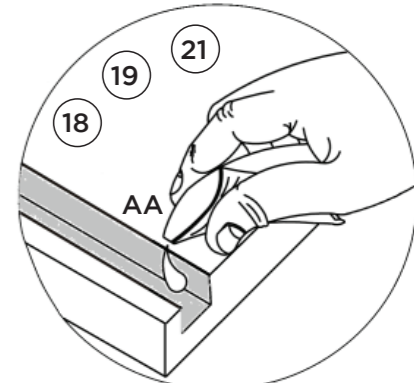
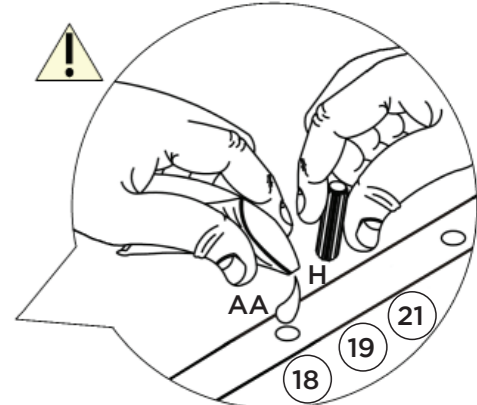
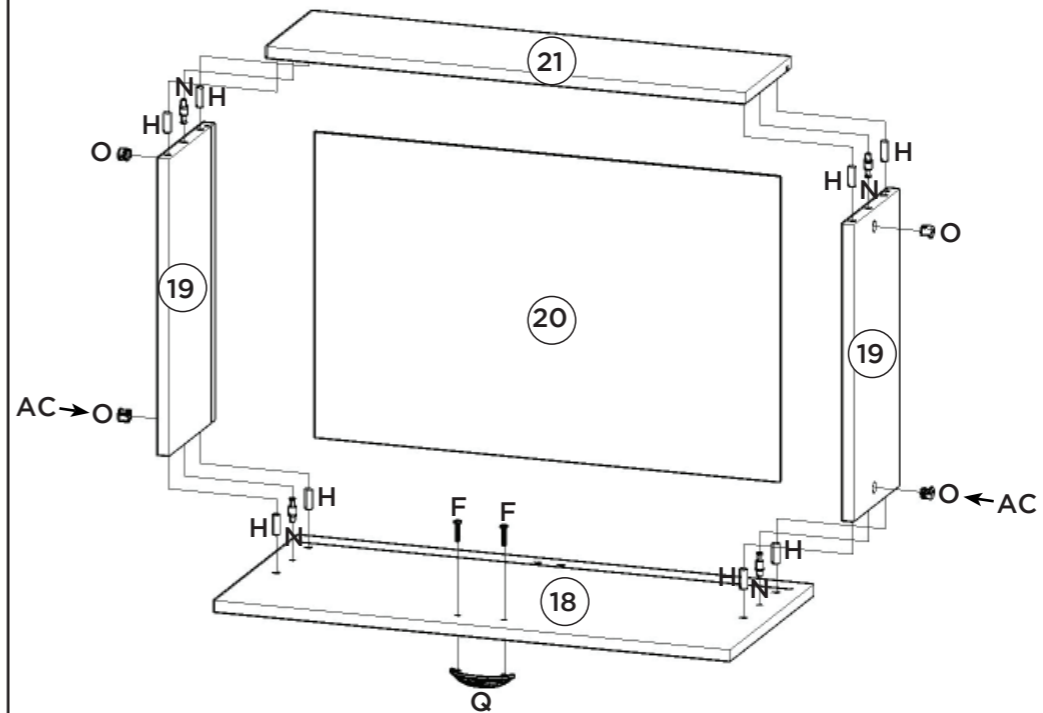
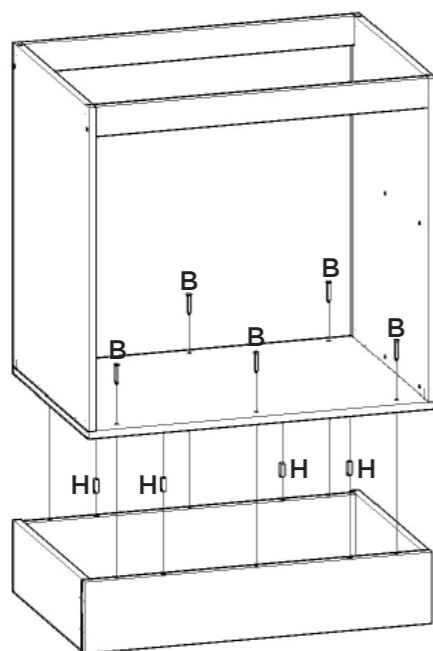
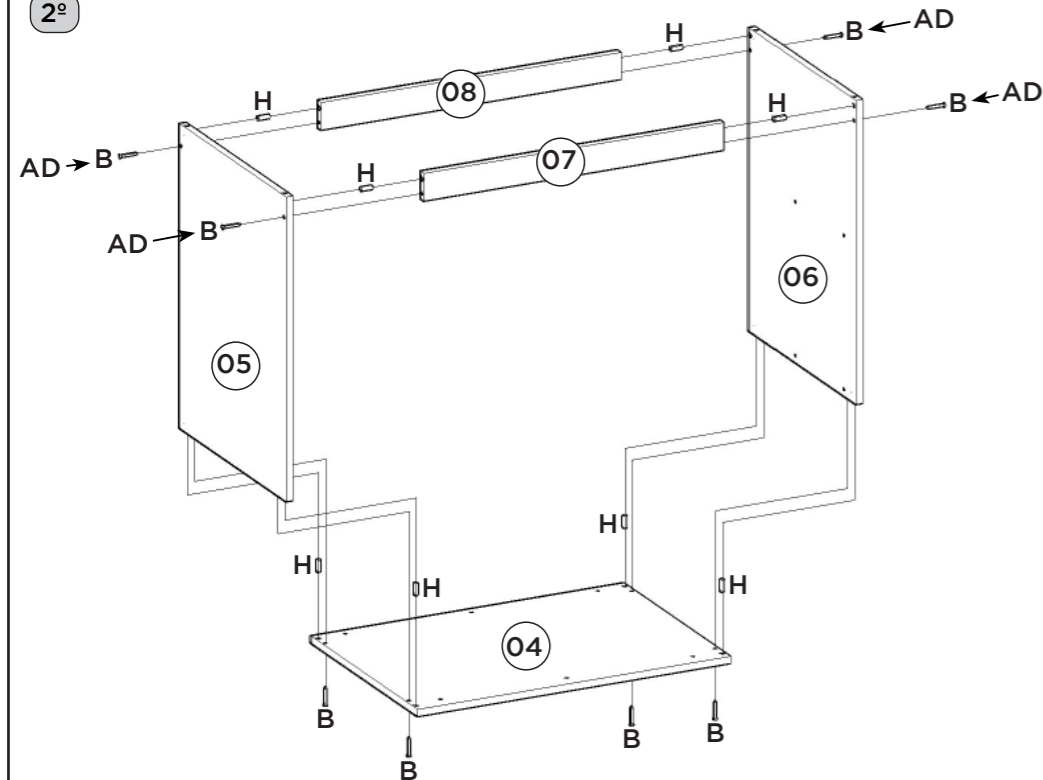

Video: Dicas para fixar o Minifix

Video: Consejos para arreglar Minifix

Video: Tips for Fixing Minifix

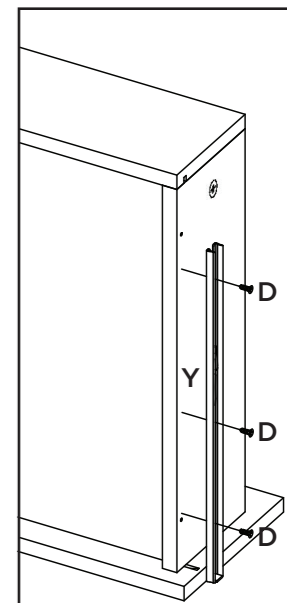
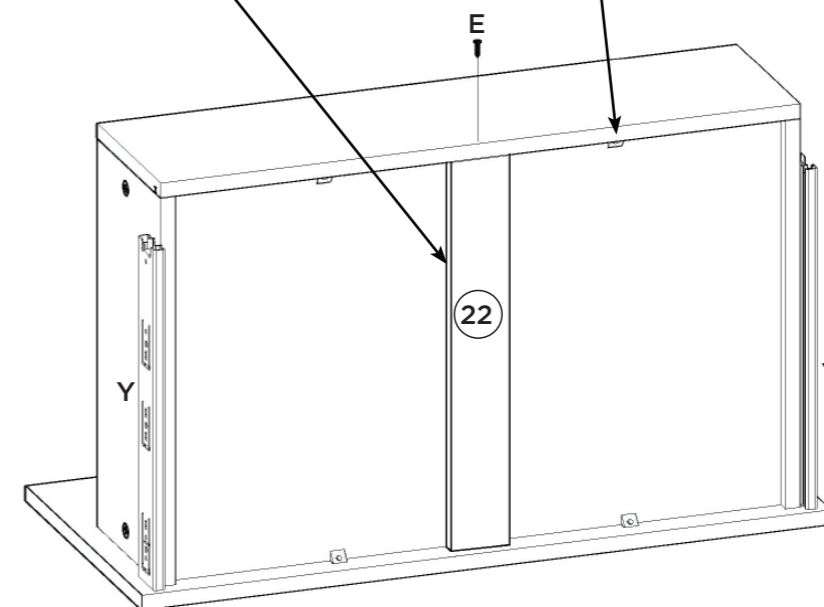
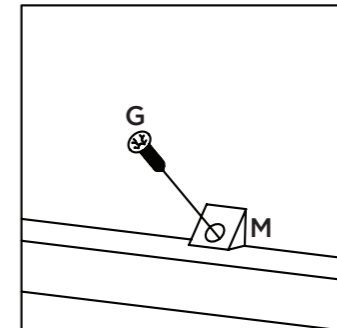
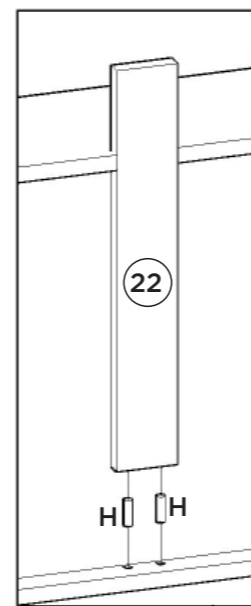



Vídeo: Instalar e regular Dobradiças

Video: Instale y ajuste las bisagras

Video: Install and adjust hinges

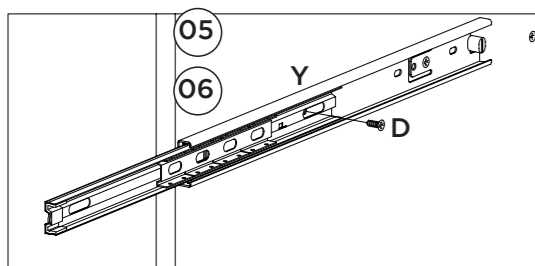
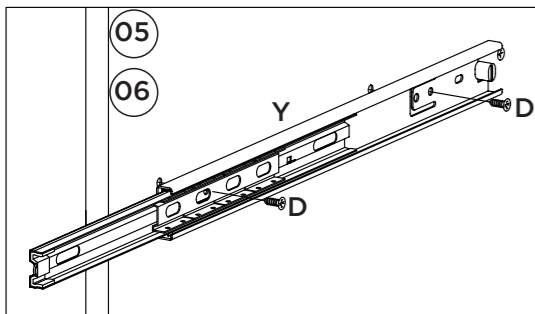
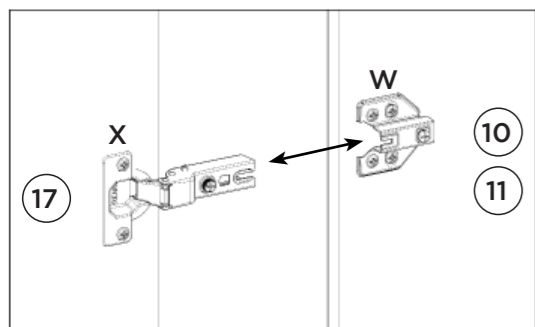
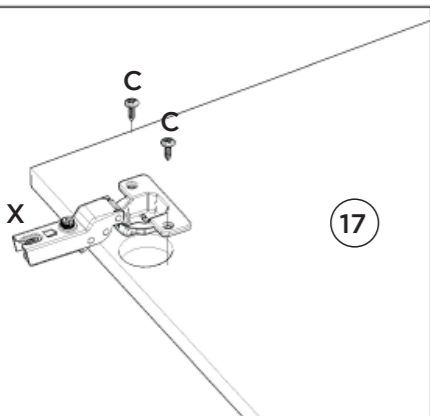
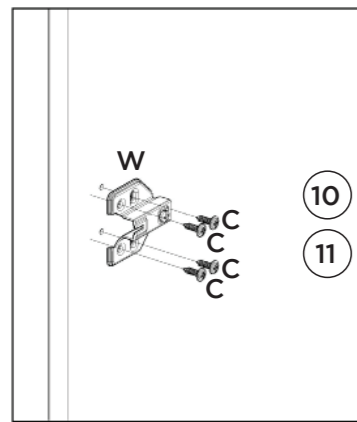

Para colocação dos puxadores, é necessário fazer a furação passante, com Broca de 5mm.

Para la colocación de las asas, es necesario perforar a través, con una broca de 5mm.

To place the handles is necessary to make the through hole, drill 5mm.

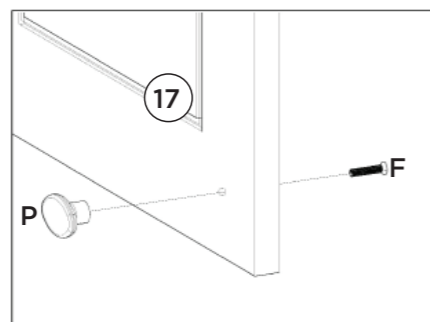

Vídeo: Dicas para fixar a Corrediça

Video: Consejos para arreglar la diapositiva

Video: Tips for Fixing the Slide

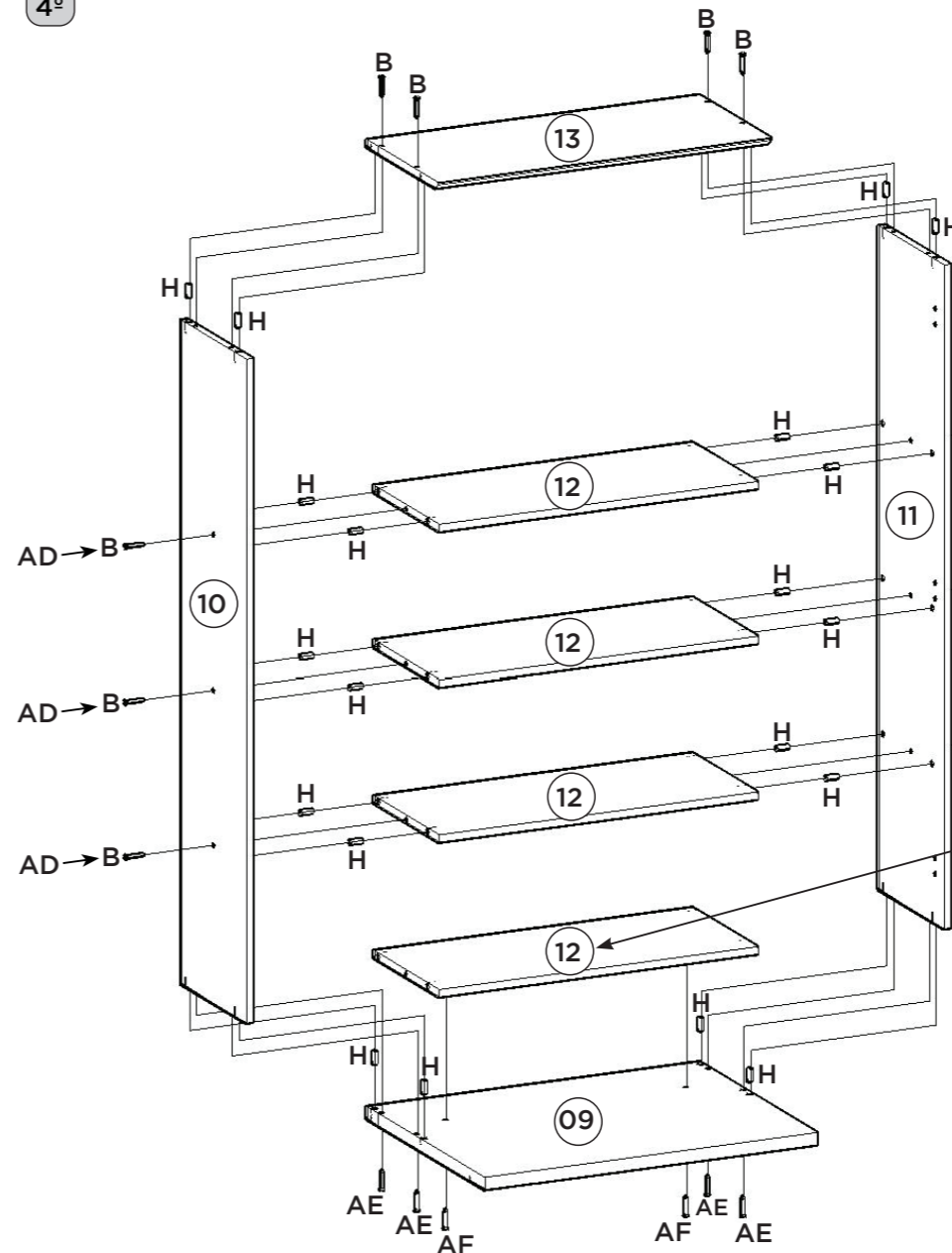
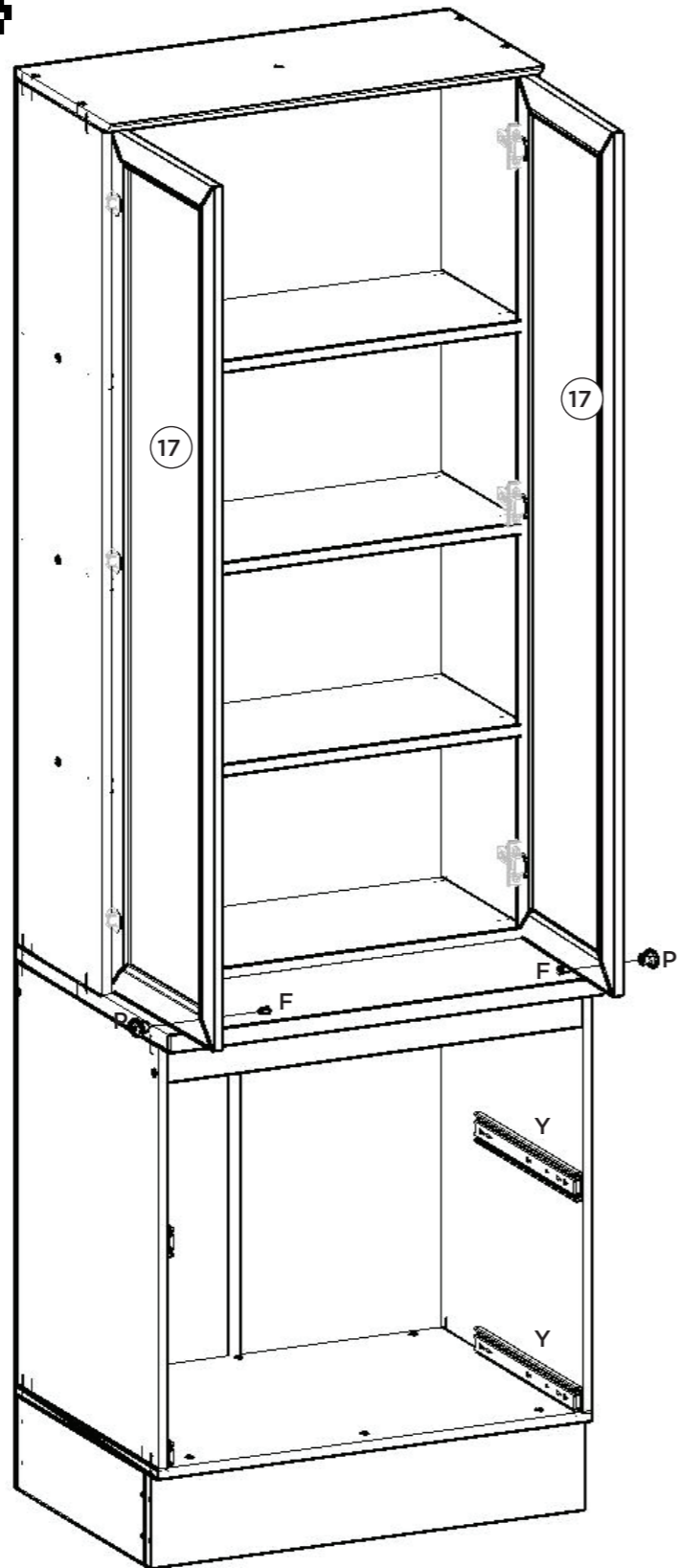

Peça (12) apenas fixada com Parafuso (AF), de baixo para cima.

Pieza (12) sólo fijada con Tornillo (AF), de abajo hacia arriba.

Part (12) only fixed with Screw (AF) from bottom to top.

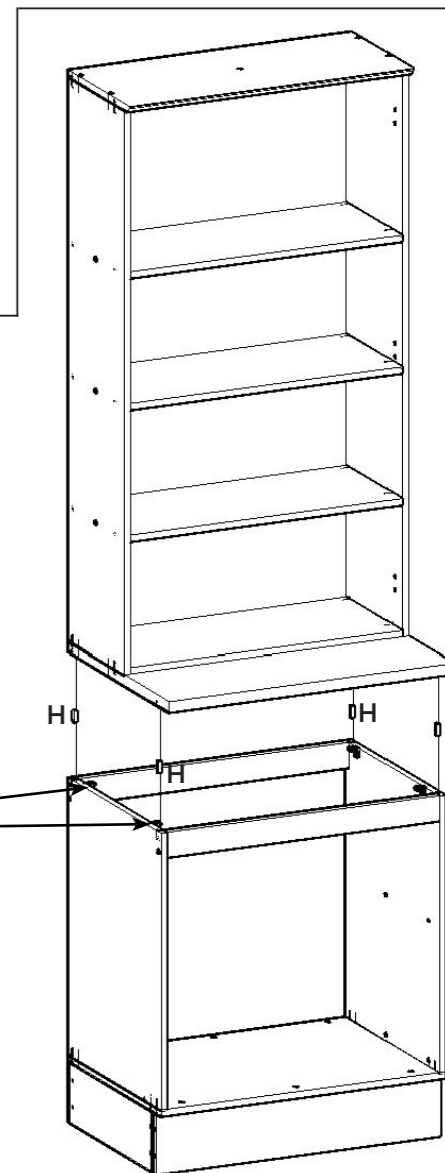
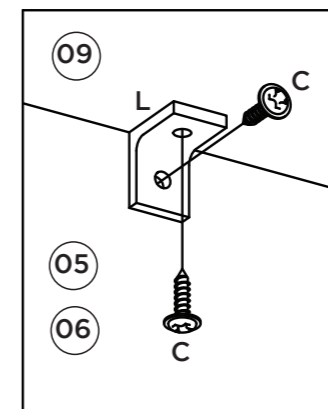

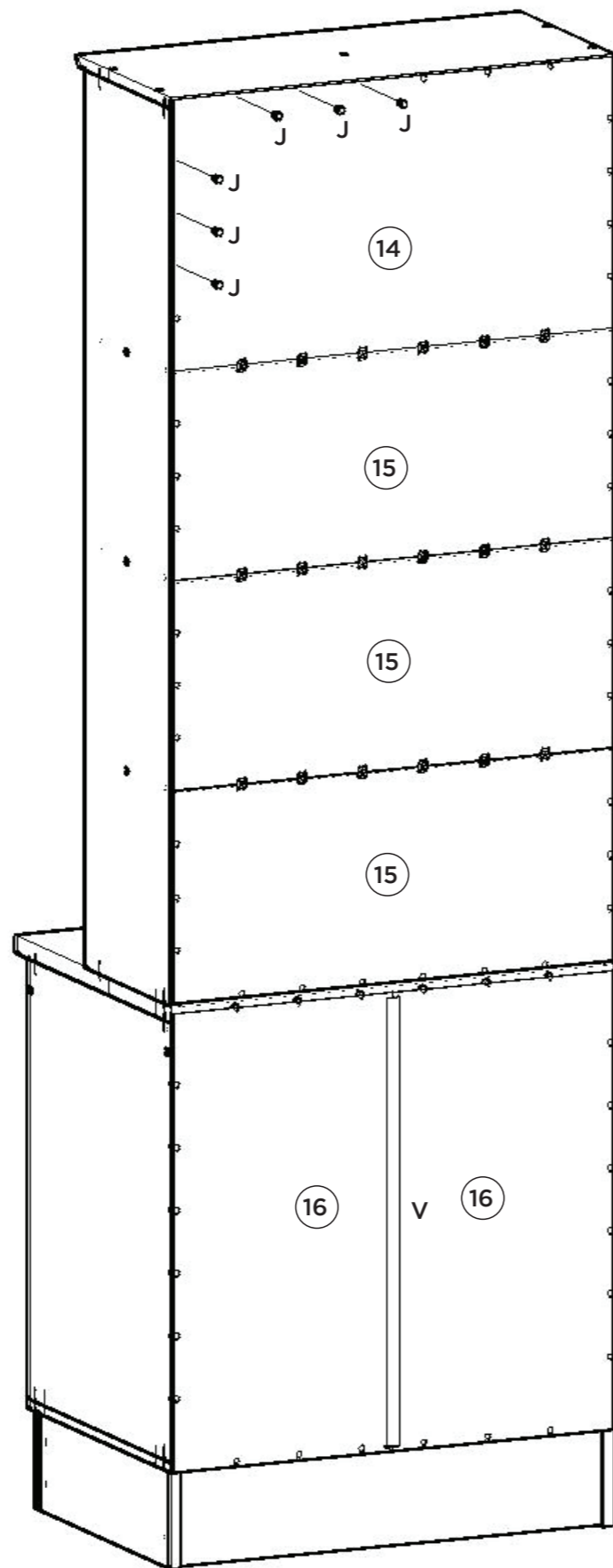
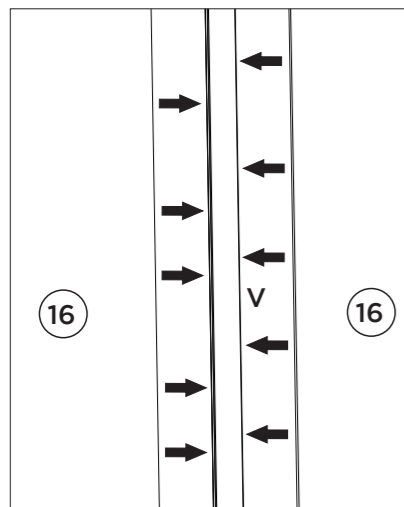
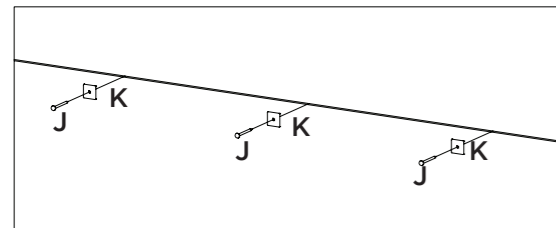

Opção Suspensa

Opción suspendida

Suspended Option

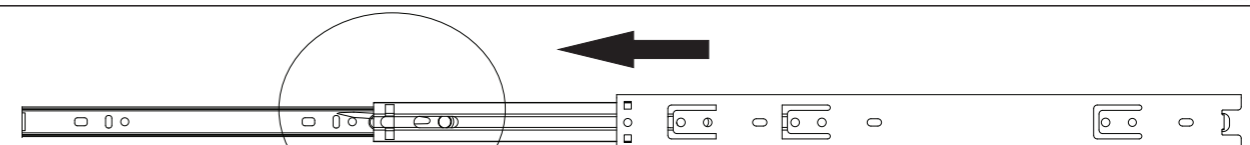
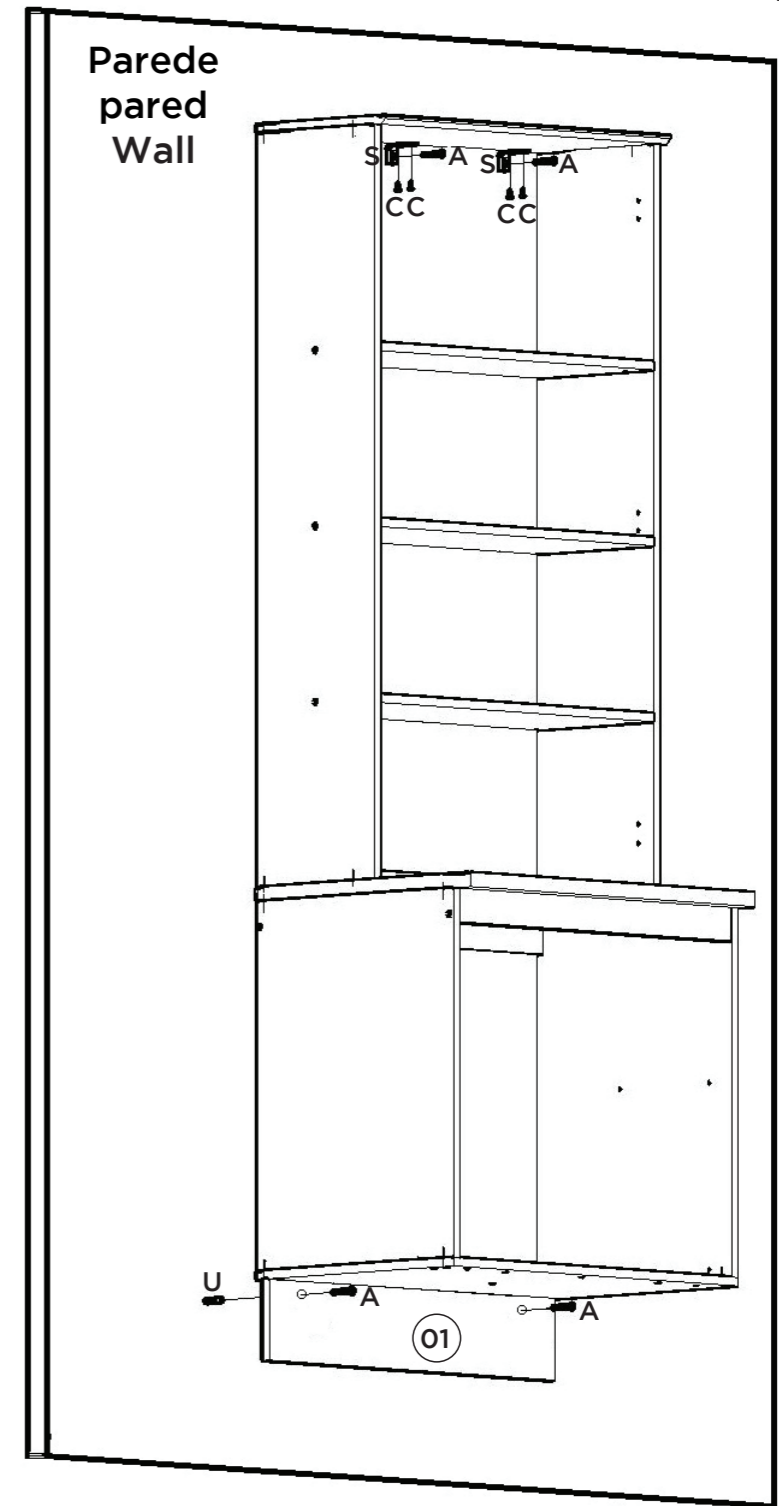
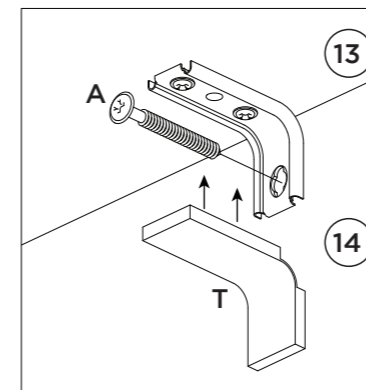
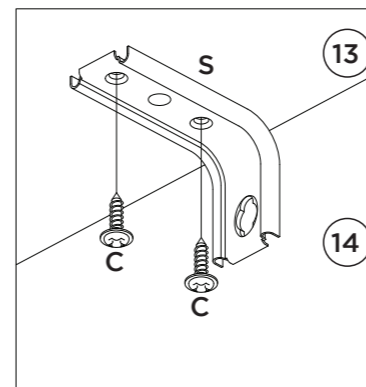

Para a desmontagem da correia siga a instrução ao lado.

Para el desmontaje seguimiento de diapositivas la instrucción siguiente a.

For the dismount of the sliding onem follows the instruction aside.

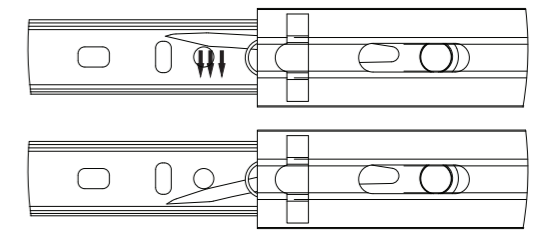

Fixar as correias nessas furações
 Fijar las diapositivas de estos agujeros
 Fix slides in these drillings

Agora que você já comprou o seu móvel, ele merece ser montado do jeito certo.

Erros de montagem causam mais de **60%** dos danos em móveis.

Por que contratar?

Tranquilidade do **início ao fim** da montagem



PROFISSIONAIS QUALIFICADOS

Especialistas certificados na **MadeiraMadeira Serviços**.



FERRAMENTAS PROFISSIONAIS

que **protegem** seus móveis.



AGENDAMENTO EM 24 HORAS

escolha a data e o turno **ideais para** você.



GARANTIA DE 3 MESES

de cobertura **completa**.

Mais de 1 MILHÃO DE MONTAGENS
★ com avaliação **4.7** ★

Mariana S., São Paulo

"Chegaram no horário e montaram tudo rapidamente. Serviço incrível!"



Carlos R., Belo Horizonte

"Tentei montar sozinho e foi um desastre. Com a **MadeiraMadeira Serviços** ficou perfeito."



Ana P., Rio de Janeiro

"Agendamento ágil e **montagem pontual e perfeita**. Recomendo demais!"



Agende agora pelo QR Code

Madeira**Madeira** Serviços · Atendimento em todo o Brasil



Escaneie o QRCode