











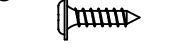

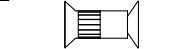

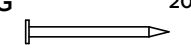

Item	Caixa Caja Box	Qtd Ctd Qty	Descrição Descripción Description	Medidas (mm) Dimensions (mm) Size (measurements) (mm)
01	1/1	01	Base Base Base	800x295x15
02	1/1	02	Lateral Direita Esquerda Lateral Derecha Izquierda Right Side Left	307x295x15
03	1/1	01	Tampo Tapa Top	800x322x15
04	1/1	01	Fundo Fondo Bottom	793x331x3
05	1/1	01	Porta Basculante Puerta Basculante Basculating Door	796x315x15

Ferragens | Herrajes | Hardware

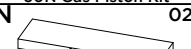
A  Parafuso 5,0x50mm FLA. Tornillo 5,0x50mm FLA. Screw 5,0x50mm FLA.	02x	B  Parafuso 3,5x40mm CHT. Tornillo 3,5x40mm CHT. Screw 3,5x40mm CHT.	08x	C  Parafuso 3,5x14mm FLA. Tornillo 3,5x14mm FLA. Screw 3,5x14mm FLA.	12x	D  Parafuso M4x20mm CHT. ZB. Tornillo M4x20mm CHT. ZB. Screw M4x20mm CHT. ZB.	01x	E  Parafuso União 15mm Tornillo Unión 15mm Union Screw 15mm	04x
F  Cavilha 8x25mm Cinta 8x25mm Dowel 8x25mm	08x	G  Prego 10x10mm Clavo 10x10mm Nail 10x10mm	20x	H  Puxador Pontual PZ14 Oval Tirador Pontual PZ14 Oval PZ14 Oval Point Knob	01x	I  Kit Pistão a Gás 60N Kit Pistón a Gas 60N 60N Gas Piston Kit	01x	J  Calço Removível Calzado extraíble Removable Shim	02x
K  Dobradilha SlideOn Super Alta Amort. 35mm Bisagra Super high amort de Slideon. 35mm Slideon Super High Amort hinge. 35mm	02x	L  Buchta plástica 8mm Buchta de plástico 8mm 8mm plastic bushing	02x	M  Suporte de fixação Soporte de fijación Mounting bracket	02x	N  Proteção para cantoneira Ángulo de protección Protection angle	02x	O  Sachê de cola Bolsa de pegamento Glue bag	01x
P  Adesivo tapan de tornillo 10mm Bolt cover adhesive 10mm	08x	Q  Parafuso União 30mm Tornillo Unión 30mm Union Screw 30mm	04x						

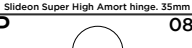
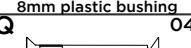
 O parafuso (Q) deve ser usada somente quando este módulo for acoplado a outro módulo componível Henn.

RECOMENDAÇÃO

Para fixar o móvel na parede usar o suporte de fixação (M), o parafuso 3,5x14mm FLA (C), a Bucha 8mm (L) e o parafuso 5,0x50mm FLA (A).

 El tornillo (Q) se debe utilizar sólo cuando el módulo está conectado a otro módulo componible Henn.

RECOMENDACIÓN

Para conectar el móvil a la pared con el soporte (M), tornillo 3,5 x14mm FLA (C), el casquillo de 8 mm (L) y el 5,0 x50mm tornillo FLA (A).

 The screw (Q) should be used only when this module is attached to another Henn modular module.

RECOMMENDATION

To fix the furniture to the wall use the fixing bracket (M), the 3.5x14mm FLA (C) screw, the 8mm bushing (L) and the 5.0x50mm FLA screw (A).

HENN

Ind. e Com. de Móveis Henn
Mondai - SC - Brasil

+55 49 3674.3500

@moveishenn
www.henn.com.br

INSTRUÇÕES DE MONTAGEM

INSTRUCCIONES DE MONTAJE
ASSEMBLY INSTRUCTIONS

Aéreo 01 Porta Basculante 800mm Americana |
Aéreo 01 Puerta Basculante 800mm Americana |
01 air port Tipper 800mm Americana

c C354-05 Branco HP
c C354-131 Cinza

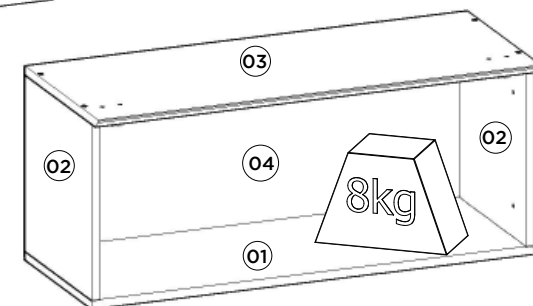
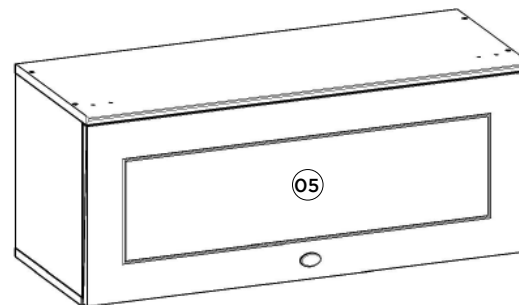

Pesos máximos recomendados com carga distribuída
Peso máximo recomendado con la carga distribuida
Recommended maximum weight with distributed load.

AVISO
Para limpeza de seu móvel, use uma flanela seca ou umedecida, e não utilize produtos químicos que possam danificar seu produto.

SISTEMA DE MONTAGEM
O sistema de montagem dos produtos funciona de acordo com a ordem crescente dos números indicados no desenho. Ex: 01, 02, 03, 04... até a conclusão da montagem.

ASSISTÊNCIA TÉCNICA
Para solicitação de Assistência Técnica você consumidor deverá entrar em contato com o Lojista a qual você realizou a compra deste produto e solicitar a assistência técnica das peças avariadas. A garantia abrange todas as peças, partes e componentes que eventualmente venham apresentar defeito de fabricação no prazo de 03 (três) meses, contando a partir da entrega do produto ao consumidor, mediante nota fiscal de compra. Se houver qualquer alteração na estrutura do produto ou ocorrer defeito por negligência do montador/consumidor em relação a instrução de montagem e manuseio, não será fornecido assistência técnica gratuita.

ADVERTENCIA
Para limpieza de su móvil, use una flanela seca o húmeda, y no utilice productos químicos que puedan dañar su producto.

SISTEMA DE MONTAJE
El sistema de montaje de los productos funciona de acuerdo con el orden creciente de los números indicados en el dibujo. Ej: 01, 02, 03, 04... hasta la conclusión del montaje.

ASISTENCIA TÉCNICA
Para solicitar Asistencia Técnica, el consumidor debe comunicarse con el Comercio que usted realizó la compra de este producto y solicita asistencia técnica para las partes dañadas. La garantía cubre todas las partes, piezas y componentes que eventualmente puedan presentar defecto de fabricación en el plazo de 03 (tres) meses, contados a partir de la entrega del producto al consumidor, mediante factura de compra. Si se produce algún cambio en la estructura del producto o se produce un defecto por negligencia del montador/consumidor en relación con las instrucciones de montaje y manipulación, no se prestará asistencia técnica gratuita.

NOTICE
To clean your furniture, use a dry or wet cloth, and do not use chemicals that may damage your product.

ASSEMBLY SYSTEM
The products' assembly system works according to the increasing order of the indicated numbers. For example: 01, 02, 03, 04 ... to the end of the assembly.

TECHNICAL ASSISTANCE
To request Technical Assistance, the consumer must contact the retailer from whom you purchased this product and request technical assistance for the damaged parts. The warranty covers all parts, parts and components that may eventually present a manufacturing defect within a period of 03 (three) months, counting from the delivery of the product to the consumer, by means of a purchase invoice. If there is any change in the structure of the product or defect occurs due to negligence of the assembler/consumer in relation to the assembly and handling instruction, free technical assistance will not be provided.

Requisitos para montagem
Requisitos para la montaje
Assembly Requirements

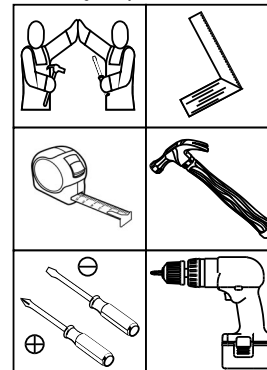

Imagens meramente ilustrativas
Imágenes meramente ilustrativas
Images for illustration only

1º

ITM/C354-

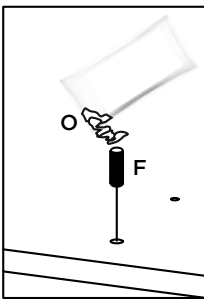
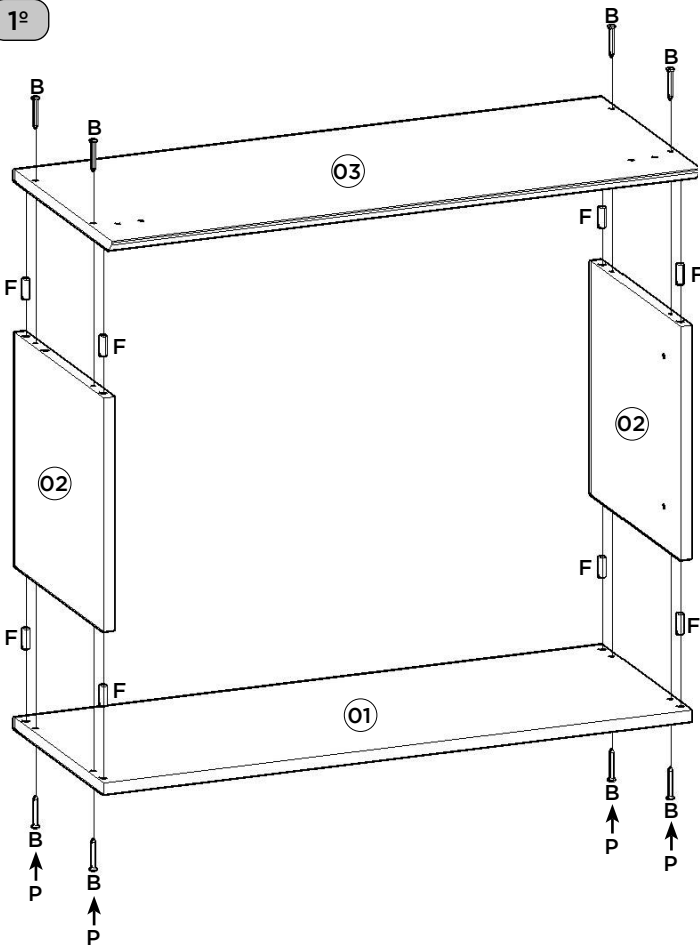

Utilizar o sachê de cola (O) em todas as cavilhas (F) do produto.

Con el pegamento sobre (O) en todos los pernos (F) producto.

Use the glue sachet (O) on all the pegs (F) of the product.

2º

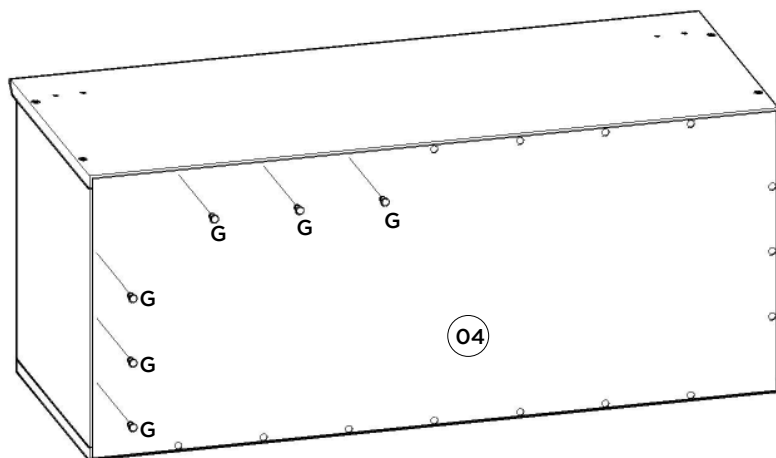

3º

ITM/C354-

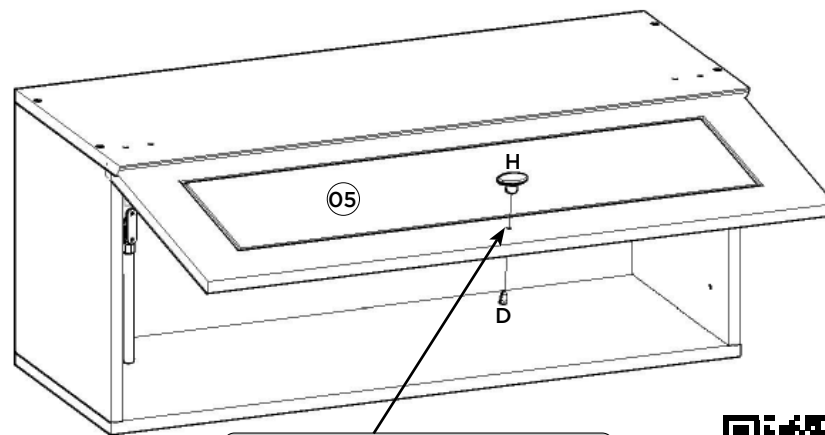

Para colocação do puxador, é necessário fazer a furação passante, com broca de 5mm.

Para colocar el mango, es necesario perforar con un taladro de 5 mm.

For placing the handle, it is necessary to drill through with a 5mm drill.



Video: Instalar e regular Dobradiças

Video: Instale y ajuste las bisagras

Video: Install and adjust hinges

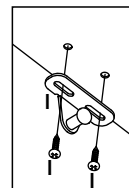
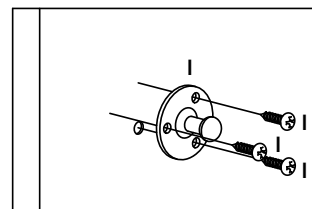
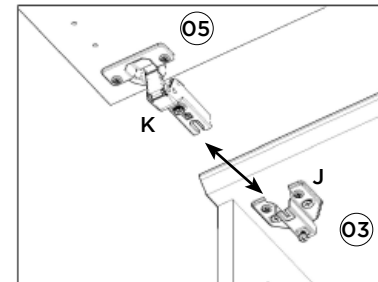
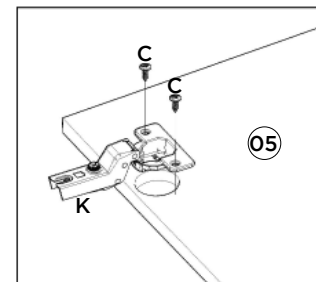
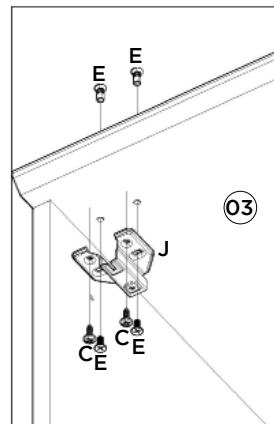

Video: Dicas para instalar o Kit Pistão à Gás

Video: Consejos para instalar el kit de pistón de gas

Video: Tips for installing the Gas Piston Kit

