

166 - CÔMODA VERONA

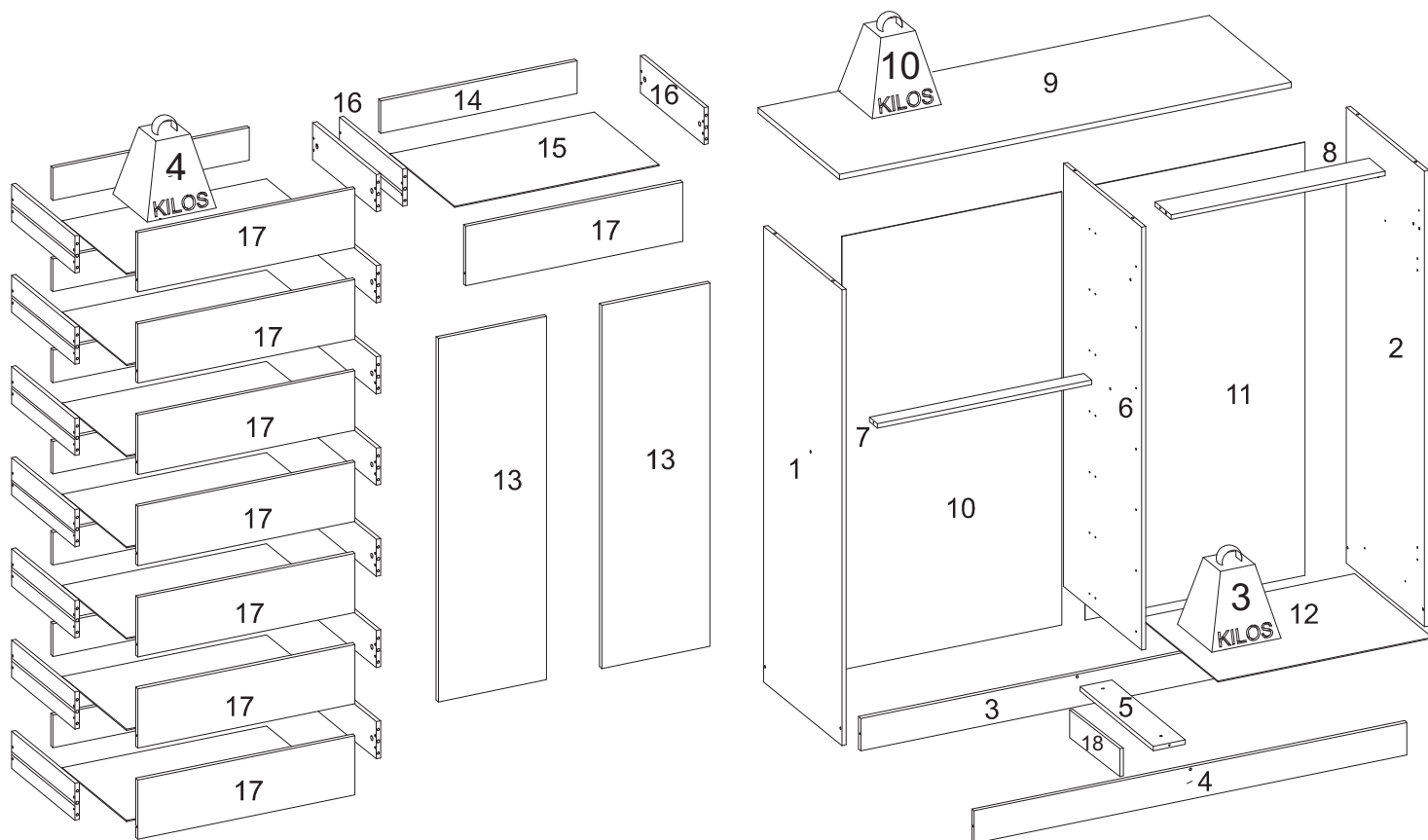

LISTA DE PEÇAS / Pieces List / Lista de Piezas

SEQ.	REF.	DESCRIÇÃO	DESCRIPTION	DESCRIPCIÓN	MAT.PRIMA	COMP.	LARG.	ESP.	QTD.
1	331338	Lateral esquerda	Left side	Lado izquierdo	MDP	1229	430	12	1
2	331339	Lateral direita	Right side	Lado derecho	MDP	1229	430	12	1
3	331340	Rodapé traseiro	Rear plinth	Zócalo trasero	MDP	1192	88	12	1
4	331341	Rodapé frontal	Front plinth	Zócalo delantero	MDP	1192	88	12	1
5	331342	Trava divisória	Partition lock	Cerradura de partición	MDP	404	88	12	1
6	331343	Divisória	Divider	Separador	MDP	1141	430	12	1
7	331344	Trava gaveta	Drawer lock	Cerradura de cajón	MDP	590	44	12	1
8	331345	Batente	Stop	Tope	MDP	590	88	12	1
9	331346	Tampo	Top	Superior	MDP	1244	450	15	1
10	331347	Fundo	Bottom	Inferior	HDF	1168	605	3	1
11	331348	Fundo porta	Door bottom	Fondo de puerta	HDF	1168	605	3	1
12	331351	Base sapateira	Shoe base	Zócalo	HDF	590	428	3	1
13	331352	Porta	Door	Puerta	MDP	980	298	12	2
14	331353	Contra fundo	Back bottom	Fondo trasero	MDP	541	88	12	8
15	331354	Fundo da gaveta	Drawer bottom	Fondo del cajón	HDF	563	355	3	8
16	331356	Lateral de gaveta	Drawer side	Lado del cajón	MDP	350	100	12	16
17	331357	Frente de gaveta	Drawer front	Frente de cajón	MDP	598	160	12	8
18	331358	Trava rodapé	Plinth lock	Cerradura de zócalo	MDP	404	75	15	1

INSTRUÇÃO MONTAGEM PRODUTO
 Instructions to Assembly / Instrucciones de montaje

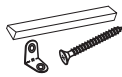

Separe as peças e acessórios de maneira organizada
 Separate parts and accessories in way organized
 Separe las piezas y accesorios de manera organizada

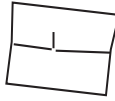

Forrar o chão com o papelão das embalagens.
 Cover the floor with the cardboard
 Cubra el suelo con la embalaje de cartón



É necessário 1 pessoa para montar o produto
 01 people are required to assemble the product
 Se requieren 01 persona para ensamblar el producto

O produto deve ser a montado por um profissional qualificado
 The product must be assembly by a professional
 El producto debe ser ensamblado por un professional calificado

Ferramentas necessárias
 (não fornecidas)

Not include tools / No herramientas



CUIDADO PARA CONSERVAÇÃO E LIMPEZA DO MÓVEL
 Care to conservation and clean / Cuidados de limpieza

Peso máximo de carga informado refere-se a objetos distribuido de maneira uniforme sobre toda área de contato da peça



The maximum load weight informed refers to objects distributed evenly over the entire contact area of the part
 Conjunto de carga máxima de peso se refiere a objetos distribuidos uniformemente sobre toda el área de contacto de la pieza de trabajo.



Não molhar o móvel e não expor em lugar úmido
 Do not wet the mobile and do not expose in a wet place
 No moje el producto y no exponer en un lugar húmedo



Não expor o móvel próximo de fontes de calor.
 Do not expose the mobile near heat sources
 no exponga cercano de fuentes de calor



Não usar produtos abrasivos.
 Do not use abrasive products.
 No utilice productos abrasivos.



Limpe com flanela limpa e seca.
 Clean with dry cloth
 Limpieza con un paño limpio y seco

LISTA DE ACESSÓRIOS E FERRAGENS / ACCESSORIES AND HARDWARE / ACCESORIOS Y HARDWARE



A- 700542-Cavilha 6x30 (40x)
 peg / cerrojo



B- 700137-Parafuso 4,5x45 (12x)
 screw / tornillo



C- 700124-Parafuso 3,5x25 (52x)
 screw / tornillo

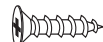

D- 700121-Parafuso 3,5x12 (204x)
 screw / tornillo



E- 700516-Sache cola 20g (2x)
 Glue / Goma



F- 700130-Parafuso 4,0x16 (2x)
 screw / tornillo

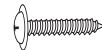

G- 700127-Parafuso 4,0x12 (16x)
 screw / tornillo



H- 700538-Cantoneira (9x)
 corner / esquina



I- 700547-Junção (9x)
 junction / juncion



J- 700146-Parafuso minifix (16x)
 Minifix screw /
 Tornillo minifix



K- 700148-Tambor Minifix (16x)
 Minifix Drum /
 Tambor minifix



L- 700379-Dobradiça (4x)
 700378- Calço (4x)
 hinge / bisagra



M 700490-KIT PÉ COM 6 UN (1x)
 Foot / Pie



N - 700113-Corrediça (8x)
 runners / corredera



O- 700419-Tapa furo minifix (38x)
 Minifix cover /
 Tapa minifix



P- 700437-Suporte meia cana (2x)
 Support / Soporte



Q- 700388-Bastão madeira 582 (1x)
 wooden rail / barra madera



R- 700157-Prego (141x)
 nail / clavo



S- 700171-Puxador 250 mm (10x)
 Handle / Manija



T- 700441-Suporte Prateleira (2x)
 Shelf Support /
 Soporte estante

01° PASSO Fixar peça 1,2,6 e 5 nas peças 3 e 4. Fixar peça 7 nas peças 1 e 6

01° STEP Fix parts 1,2,6 and 5 to parts 3 and 4. Fix part 7 to parts 1 and 6.

01° PASO Fijar las piezas 1,2,6 y 5 a las piezas 3 y 4. Fijar la pieza 7 a las piezas 1 y 6.

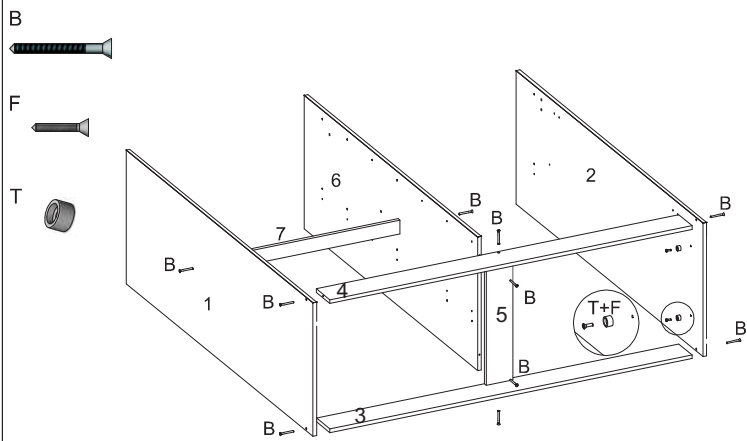

02° PASSO Fixar a peça 18 na peça 3, 4 e 5

02° STEP Fix part 18 to part 3, 4 and 5

02° PASO Fije la parte 18 a la parte 3, 4 y 5

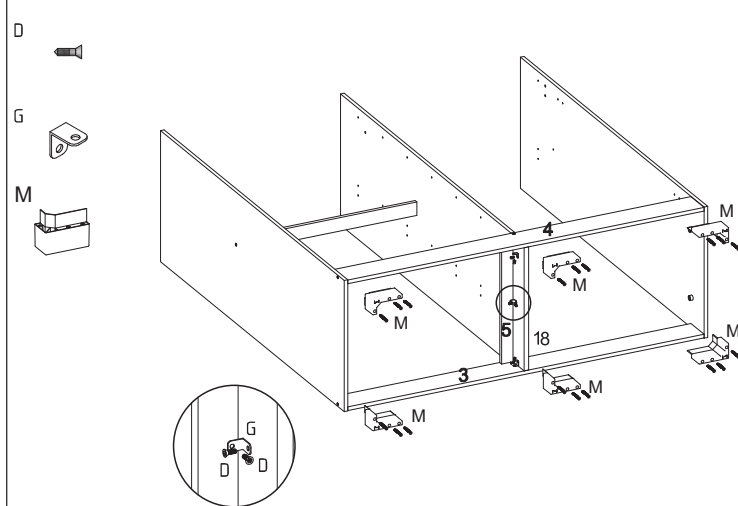

02° PASSO Fixar a peça 8 nas peças 2 e 6, fixar a peça 9 nas peças 1,2 e 6.

02° STEP Secure part 8 to parts 2 and 6, fix part 9 to parts 1,2 and 6.

02° PASO Asegure la parte 8 a las partes 2 y 6, fije la parte 9 a las partes 1,2 y 6.

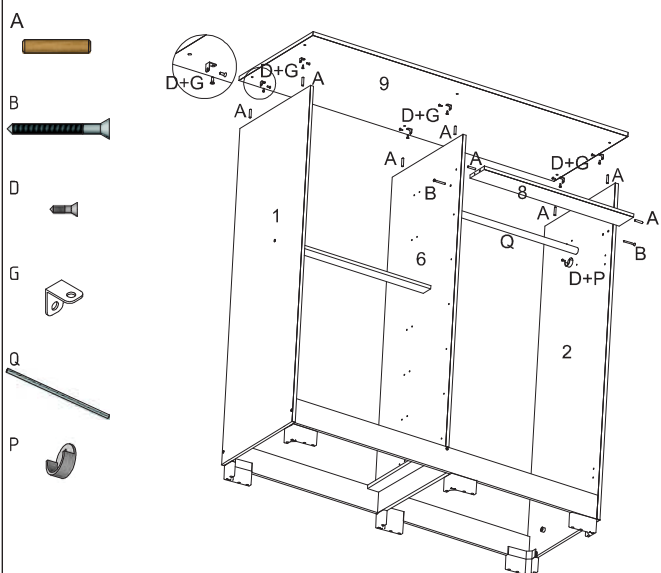

03° PASSO Fixar a peça 12 nas peças 3 e 4

03° STEP Attach part 12 to parts 3 and 4

03° PASO Adjunte la parte 12 a las partes 3 y 4

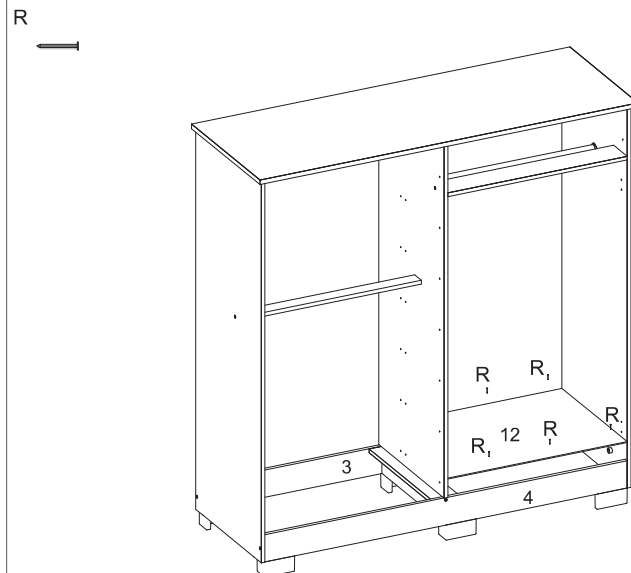

04° PASSO Fixar os acessórios N nas peças 1,2 e 6

04° STEP Attach accessories N to parts 1,2 and 6

04° PASO Conecte los accesorios N a las partes 1,2 y 6

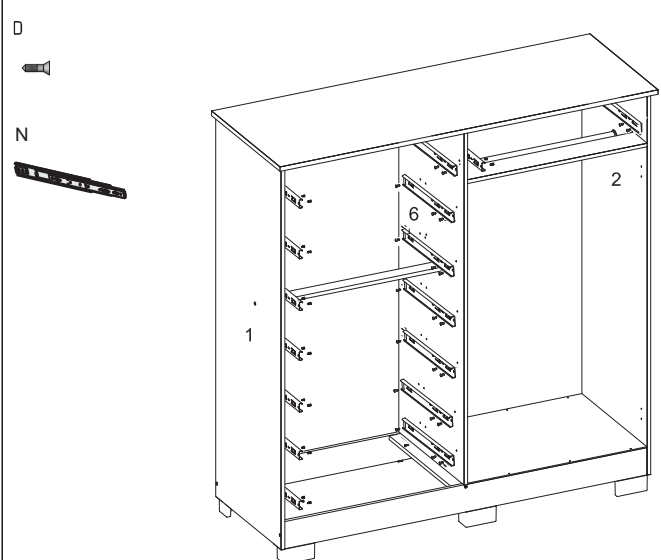

05° PASSO Fixar as peças 10 e 11 utilizando as ferragens I e R.

05° STEP Secure parts 10 and 11 using hardware I and R.

05° PASO Asegure las partes 10 y 11 utilizando el hardware I y R.

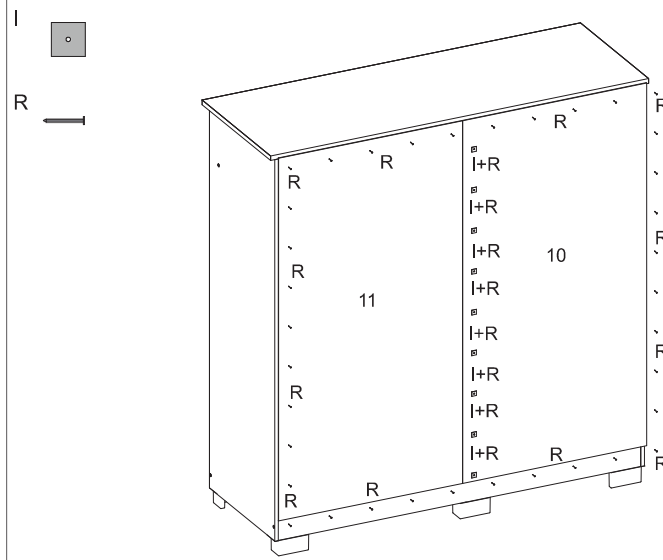

06° PASSO Fixar as peças 13 nas peças 2 e 6.

06° STEP Secure pieces 13 to parts 2 and 6.

06° PASO Asegure las piezas 13 a las partes 2 y 6.

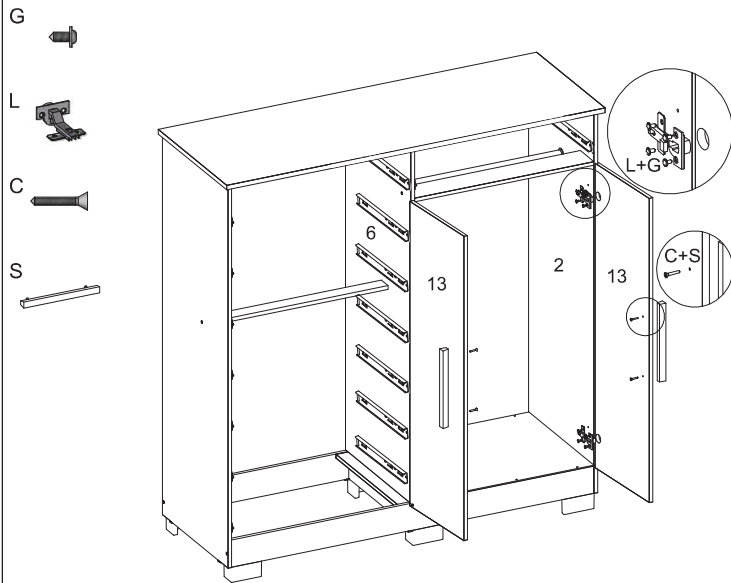

07° PASSO Fixar as peças 14 e 17 nas peças 16

07° STEP Attach parts 14 and 17 to parts 16

07° PASO Adjunte las partes 14 y 17 a las partes 16

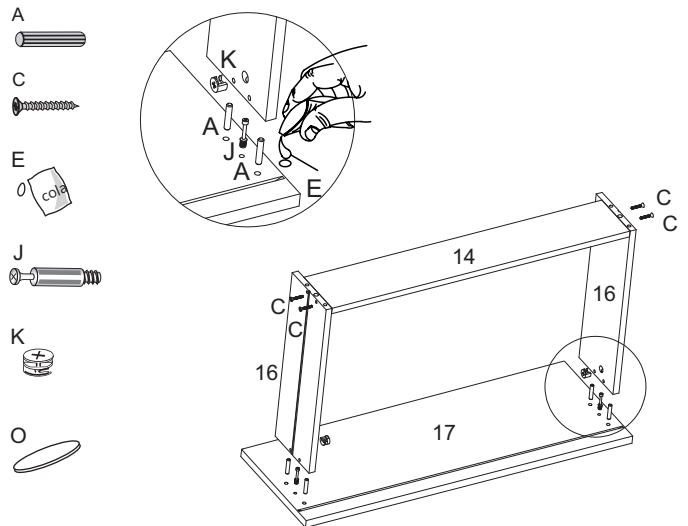

08° PASSO - Fixar peça 15 nas peças 14 e 16

08° STEP - Attach part 15 to parts 14 and 16

08° PASO - Adjunte la parte 15 a las partes 14 y 16

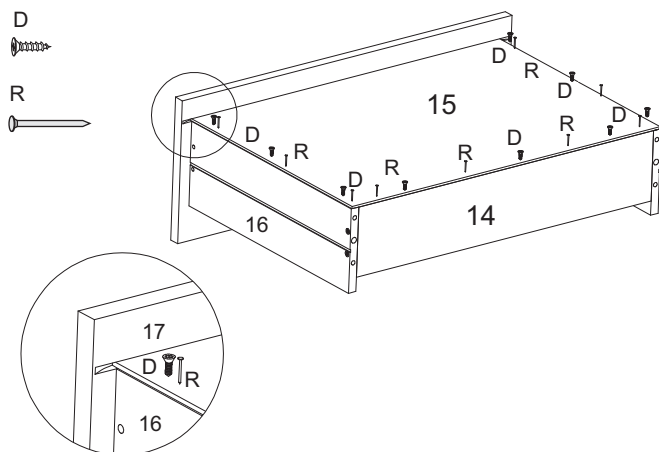

09° PASSO - Fixar os acessórios N nas peças 16, acessório S na peça 17

09° STEP - Attach accessories N to parts 16, accessory S to part 17

09° PASO - Conecte los accesorios N a la pieza 16, el accesorio S a la pieza 17

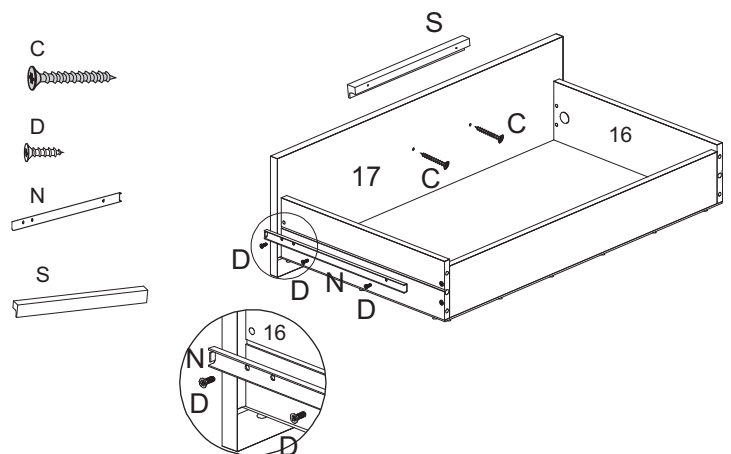

Aspecto final do produto

Final appearance of the product

Aspecto final del producto

