

**MÓDULO IND. 2 GAVETAS 3 PRAT / IND. MODULE 2 DRAWERS 3 SHELVES / MÓDULO IND. 2 CAJONES 3 REPISAS
PH-1775**

Montagem

Recomenda-se a leitura prévia das instruções de montagem e profissionais especializados para montar.

Assistência

Caso ocorra problema com algum dos componentes, sublinhe-o, identifique o problema e retorne esta relação, via fax ou outro meio de comunicação disponível para o representante.

Assinatura do cliente

Assembly

Before the assembling is recommended to read carefully the assembly instruction by professional assemblers.

Assistence

If happen problems with any component, underline the same, identify the problem and send back this relation immediatly, by fax or other way.

Client signature

Montaje

Se recomienda la lectura previa de las instrucciones de montaje y profesionales especializados para montarlos.

Assistencia

Caso sucedan problemas con alguno de los componentes, subraye el componente, identifique el problema, y retorne esta copia via fax u otro medio de comunicación posible.

Assinatura del cliente

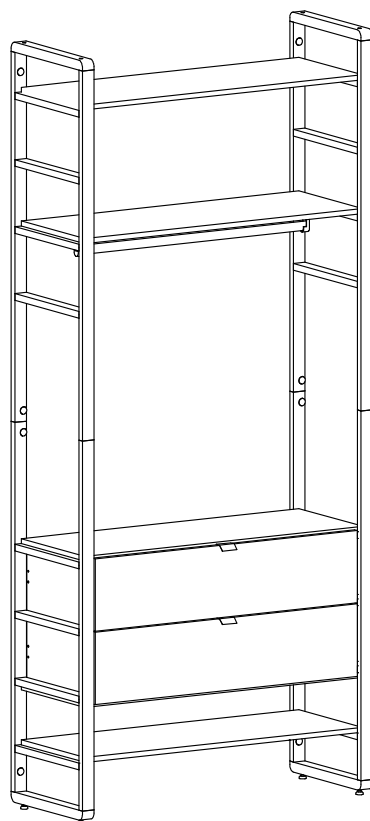

Atenção / Attention / Atención

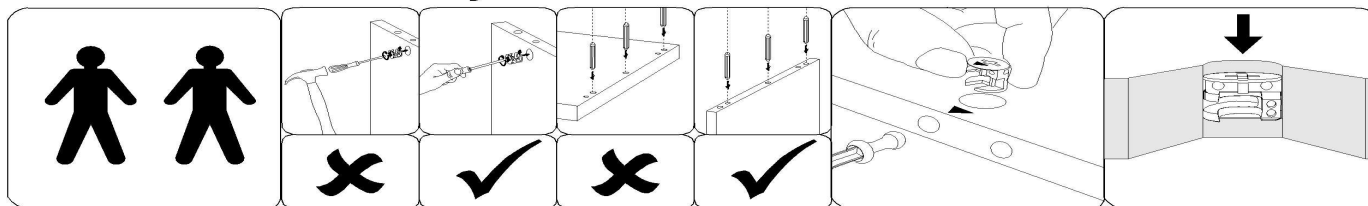

A Heval se reserva o direito de efetuar alterações nos produtos de suas linhas sem aviso prévio, quando entender necessário.

Herval reserves the right to effect modifications in the products, without previous advice, when understand necessary.

Herval se reserva el derecho de hacer las modificaciones que juzgue necesarias en sus productos, sin aviso previo, cuando lo crea necesario.

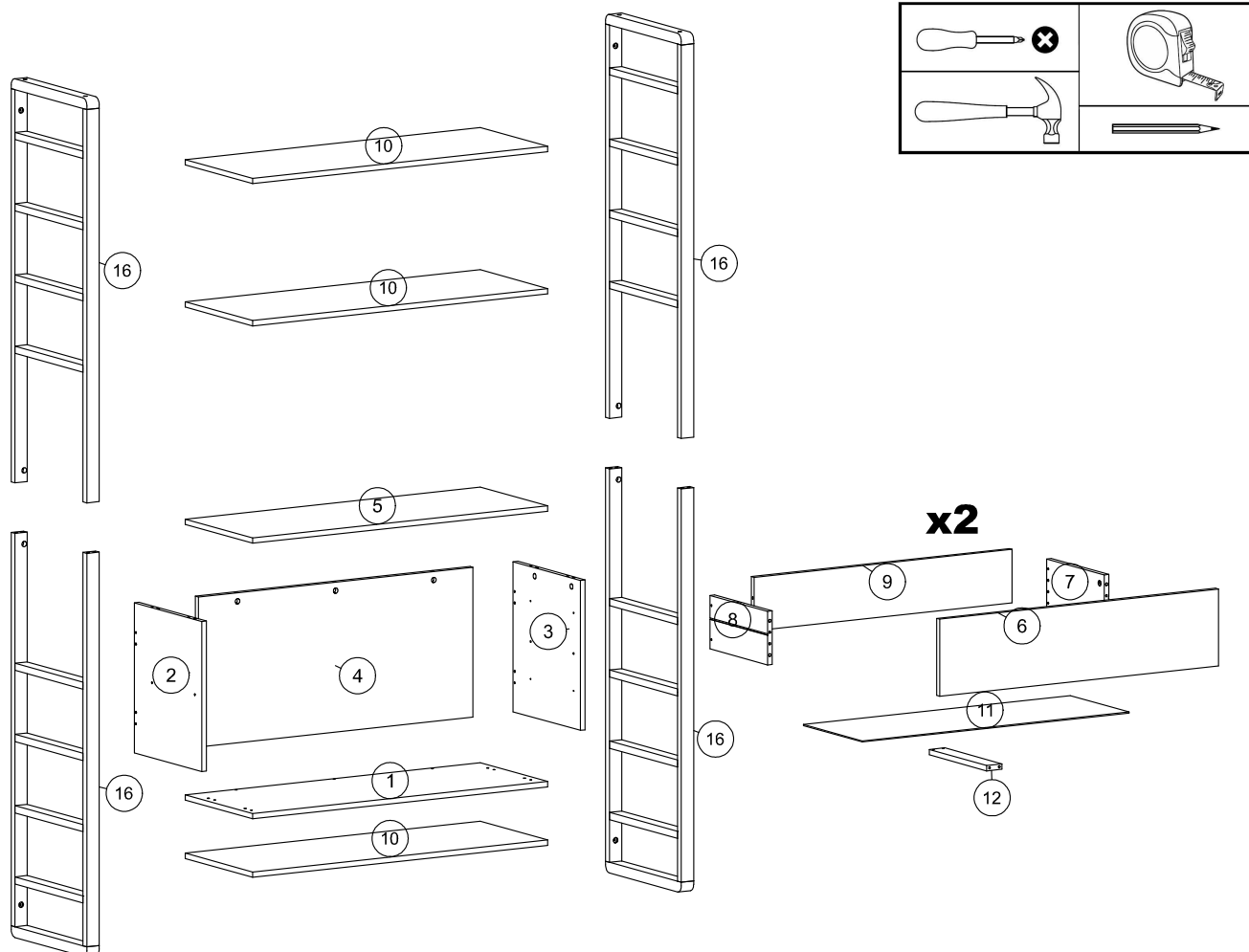

LISTA DE PEÇAS / PARTS LIST / LISTA DE PIEZAS

x2 Volume 1 / Carton 1 / Caja 1				
ÍNDICE / INDEX	CÓD. / CODE	PEÇA / PART / PIEZA	MED/MEASURE	QTDE / QUANT / CANT
16	6137230	VOL 1 MODULO LATERAL MAD PH1775	xx	1
-	K072681	KIT VOL 1 MODULO LATERAL MAD PH1775	xx	1

Volume 2 / Carton 2 / Caja 2				
ÍNDICE / INDEX	CÓD. / CODE	PEÇA / PART / PIEZA	MED/MEASURE	QTDE / QUANT / CANT
1	159382E	BASE	962.0x352.0x15.0	1
2	159368E	LATERAL ESQ	351.0x421.0x15.0	1
3	159369E	LATERAL DIREITA	351.0x421.0x15.0	1
4	159370E	TRASEIRO	896.0x421.0x15.0	1
5	159367E	TAMPO	962.0x352.0x15.0	1
6	159371E	FRENTE DE GAVETA	909.0x216.0x15.0	2
7	159372E	LATERAL GAV DIR	300.0x150.0x15.0	2
8	159373E	LATERAL GAV ESQ	300.0x150.0x15.0	2
9	159374E	TRASEIRO DE GAV	841.0x150.0x15.0	2
10	159377E	PRATELEIRA	962.0x352.0x15.0	3
11	159376E	FUNDO GAV	870.0x307.0x3.0	2
12	159375E	SUPORTE GAV	300.0x50.0x15.0	2
13	1606841	TRILHO TELESCÓPICO TN H32 300mm Z	xx	2
14	1609323	PUXADOR VERONA PINTADO 50MM (PRETO PV097)	50.0x35.0x15.7	2
15	159386E	TUBO OBL CAB MADEIRA 795MM (PRETO)	795.0x28.0x15.8	1
-	K072678	KIT VOLUME-2 MÓD. INDUSTRIAL 2 GAV. 3 PRAT.	xx	1

LISTA DE ACESSÓRIOS / FITTINGS LIST / LISTA DE ACESSORIOS

KIT VOLUME 1**CÓD./ CODE: K072681**

REF.	PEÇA	PART	PIEZA	QTDE	CÓDIGO
M	BUCHA 8mm	Wall Plug 8MM	Enchufe de Pared 8MM	2	1602625
N	TAPA FURO ADESIVO PAPEL 22MM	Hole Plugs 22mm	Tapa Hueco 22mm	8	XXXXXXXX
O	CJ.HASTE63MM DUPLA C/2 TAB.MFIX 0902112411	Double Rod Set 63mm	Juego de Varillas Dobles 63mm	2	1602819
P	SAPATA NIQUELADA 20mm	Nickel plated shoe 20mm	Zapato Niquelado 20mm	2	-
Q	PARAFUSO 5 X 60 CAB. FLANGEADO	Screw Ø5 x 60 mm	Tornillo Ø5 x 60 mm	2	1604708
R	CAVILHA MADEIRA 8X40	Dowel 8x40	Tarugo 8x40	2	-

KIT VOLUME 2**CÓD./ CODE: K072678**

REF.	PEÇA	PART	PIEZA	QTDE	CÓDIGO
A	PARAFUSO MINIFIX	Cam Bolt 32xØ6mm	Perno de Leva 32xØ6mm	15	1602006
B	TAMBOR MINIFIX Ø14.9X11MM	Can Nut Ø15 mm	Porca de Leva Ø15 mm	15	1605358
C	PREGO 10 X 10 C/CABEÇA - Ø1,5 x 23mm	Nail 10x10 - Ø1,5 x 23mm	Clavo 10x10 - Ø1,5 x 23mm	28	1605365
D	TAPA FURO ADESIVO PAPEL 15mm	Hole Plugs Adhesive 15mm	Tapa Hueco 15mm	4	-
E	CANTONEIRA DE FIXAÇÃO COM FURO (04.08.115)	-	-	12	-
F	SUPORTE CABIDEIRO U	Support Pipe U	Soporte Tubería	2	04.02.088
G	TAPA FURO ADESIVO PAPEL 22MM	Hole Plugs 22mm	Tapa Hueco 22mm	8	XXXXXXXX
H	CAVILHA DE MADEIRA 6X40	Dowel Ø6 x 40 mm	Tarugo Ø6 x 40 mm	32	1604742
I	PARAFUSO 4 X 40 CAB. CHATA PHILIPS	Screw Ø4 x 40 mm	Tornillo Ø4 x 40 mm	19	1604937
J	PARAFUSO 3.5 X 22 CAB. CHATA PHILIPS	Screw Ø3.5 x 22 mm	Tornillo Ø3.5 x 22 mm	4	1607844
K	PARAFUSO 4 X 14 CAB. CHATA REBAIXADA PHILIPS	Screw Ø4 x 14 mm	Tornillo Ø4 x 14 mm	44	1602420
L	PARAFUSO 3 X 30 CAB. CHATA PHILIPS	Screw Ø3 x 30 mm	Tornillo Ø3 x 30 mm	8	1607848

*** O Modulado Industrial Édez pode ser montado de diversas formas, unindo vários módulos, formando o ambiente que desejar.**

*** Édez Industrial Module can be assembled in different ways, joining several modules, forming the environment you want.**

*** Modulado Industrial Édez se puede ensamblar de diferentes maneras, uniendo varios módulos, formando el ambiente que deseas.**

Módulo Duplo 3 Gavetas 6 Prateleiras
Double Module 3 Drawers 6 Shelves
Modulo Doble 3 Cajones 6 Repisas

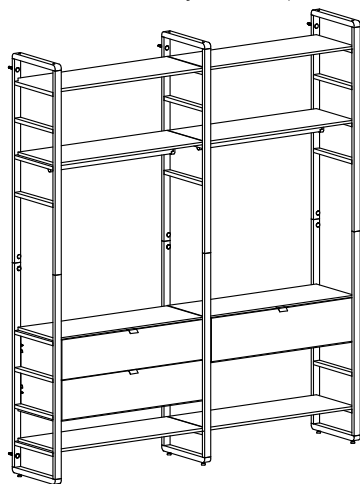

Módulo Triplo 3 Gavetas 14 Prateleiras
Triple Module 3 Drawers 14 Shelves
Modulo Triplo 3 Cajones 14 Repisas

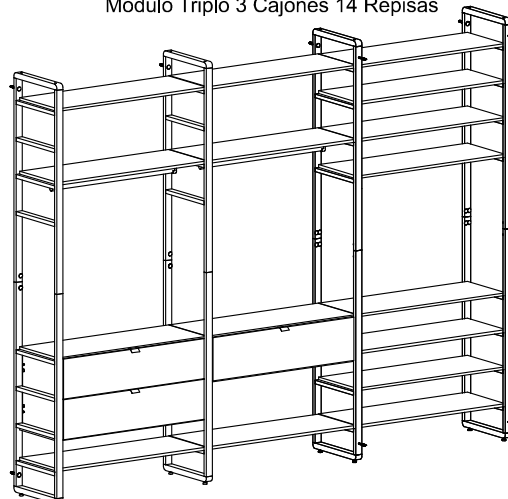

**PASSO 1
STEP 1
PASO 1**

PEÇAS NECESSÁRIAS
PARTS REQUIRED
PIEZAS NECESARIAS

INDICE	QUANT.
5	1

FERRAGEM NECESSÁRIA
HARDWARE REQUIRED
HERRAMIENTA NECESARIA

INDICE	IMAGEM	QTDE
A		7

FERRAMENTAS NECESSÁRIAS
TOOL REQUIRED
HERRAMIENTA NECESARIA

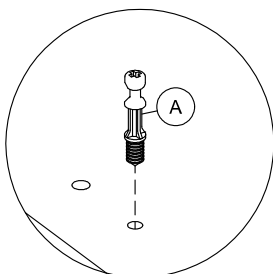
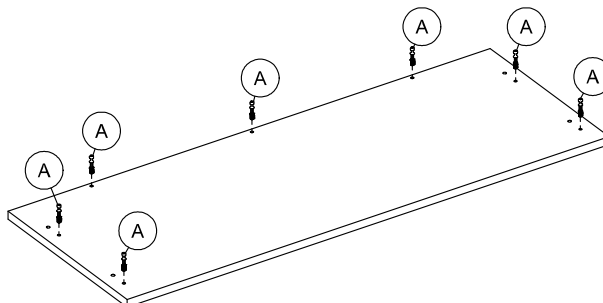
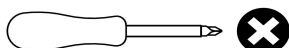



**PASSO 2
STEP 2
PASO 2**

PEÇAS NECESSÁRIAS
PARTS REQUIRED
PIEZAS NECESARIAS

INDICE	QUANT.
2	1
3	1
13	2

FERRAGEM NECESSÁRIA
HARDWARE REQUIRED
HERRAMIENTA NECESARIA

INDICE	IMAGEM	QTDE
H		8
K		8

FERRAMENTAS NECESSÁRIAS
TOOL REQUIRED
HERRAMIENTA NECESARIA

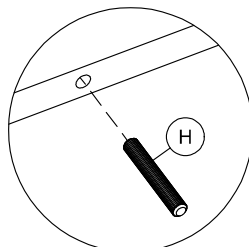
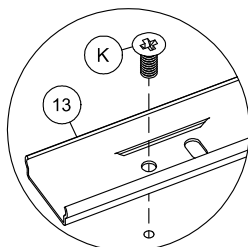
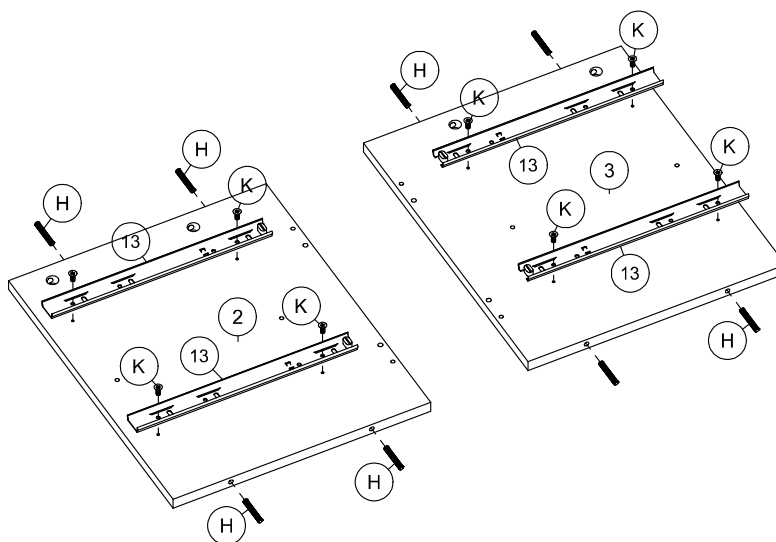
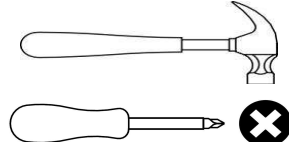

**PASSO 3
STEP 3
PASO 3**

PEÇAS NECESSÁRIAS
PARTS REQUIRED
PIEZAS NECESARIAS

INDICE	QUANT.
4	1

FERRAGEM NECESSÁRIA
HARDWARE REQUIRED
HERRAMIENTA NECESSARIA

INDICE	IMAGEM	QTDE
H		4

FERRAMENTAS NECESSÁRIAS
TOOL REQUIRED
HERRAMIENTA NECESSARIA

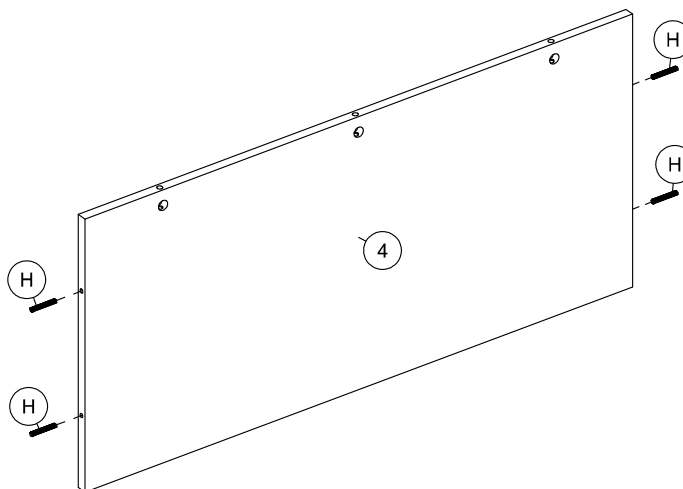
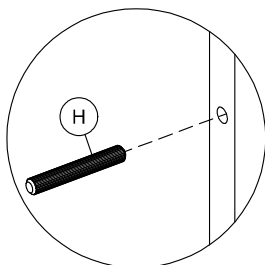
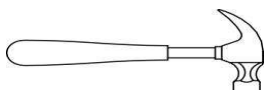

**PASSO 4
STEP 4
PASO 4**

PEÇAS NECESSÁRIAS
PARTS REQUIRED
PIEZAS NECESARIAS

INDICE	QUANT.
2	1
3	1
4	1

FERRAGEM NECESSÁRIA
HARDWARE REQUIRED
HERRAMIENTA NECESSARIA

INDICE	IMAGEM	QTDE
I		4

FERRAMENTAS NECESSÁRIAS
TOOL REQUIRED
HERRAMIENTA NECESSARIA

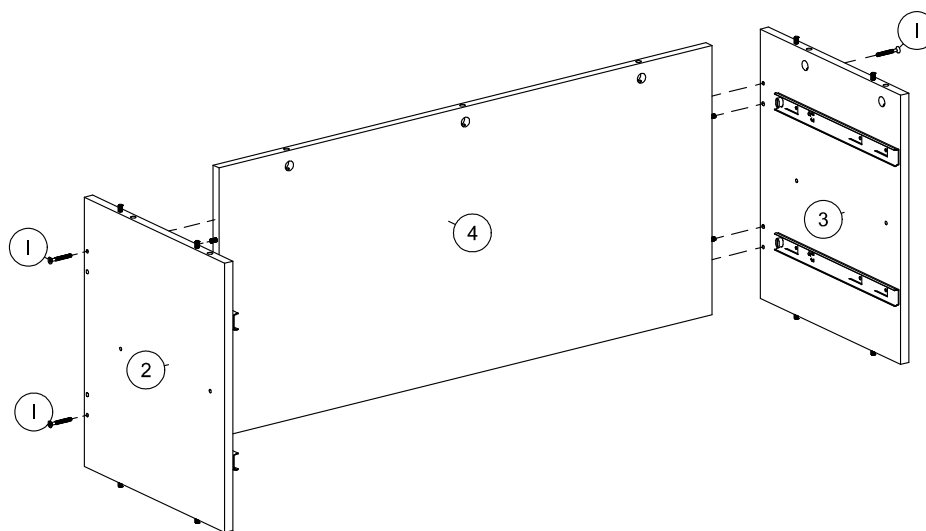
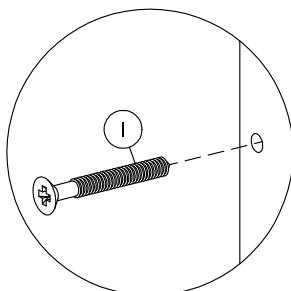
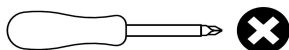

**PASSO 5
STEP 5
PASO 5**

PEÇAS NECESSÁRIAS
PARTS REQUIRED
PIEZAS NECESARIAS

INDICE	QUANT.
1	1

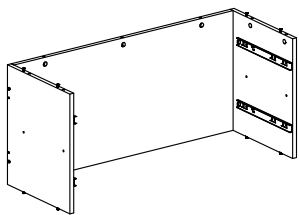

FERRAGEM NECESSÁRIA
HARDWARE REQUIRED
HERRAMIENTA NECESSARIA

INDICE	IMAGEM	QTDE
1		7

FERRAMENTAS NECESSÁRIAS
TOOL REQUIRED
HERRAMIENTA NECESSARIA

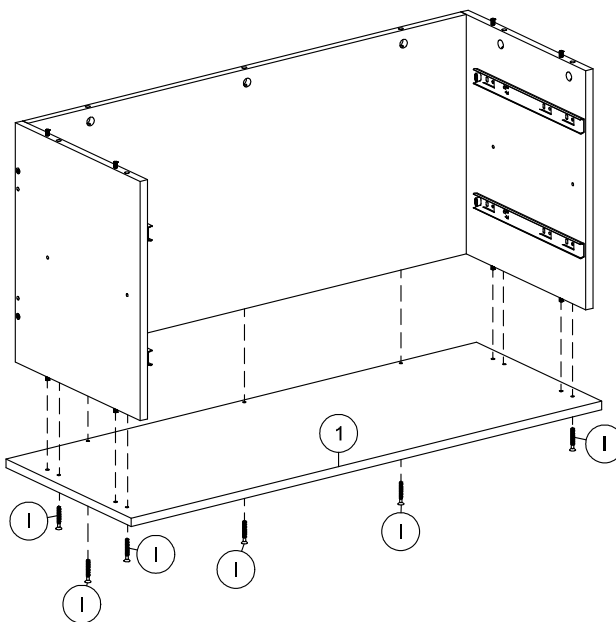
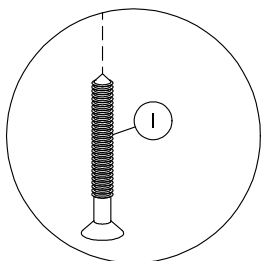
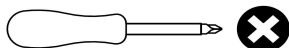

**PASSO 6
STEP 6
PASO 6**

PEÇAS NECESSÁRIAS
PARTS REQUIRED
PIEZAS NECESARIAS

INDICE	QUANT.
5	1

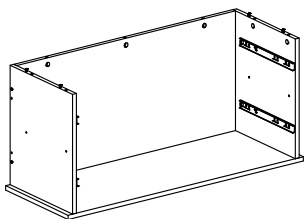

FERRAGEM NECESSÁRIA
HARDWARE REQUIRED
HERRAMIENTA NECESSARIA

INDICE	IMAGEM	QTDE
B		7

FERRAMENTAS NECESSÁRIAS
TOOL REQUIRED
HERRAMIENTA NECESSARIA

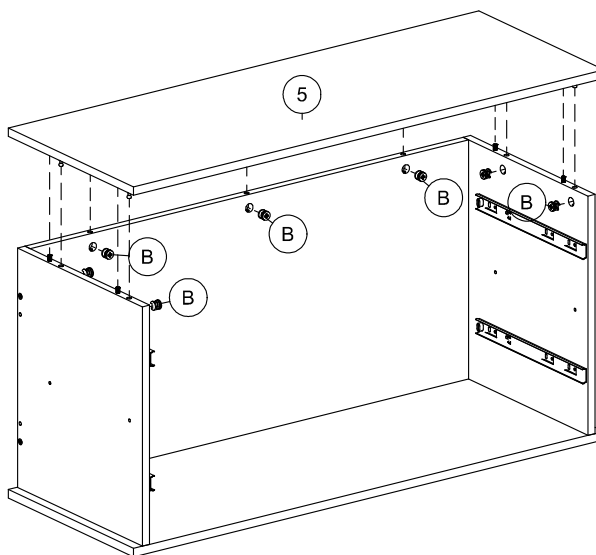
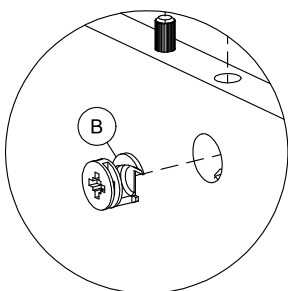
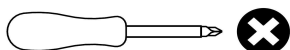





**PASSO 7
STEP 7
PASO 7**

PEÇAS NECESSÁRIAS
PARTS REQUIRED
PIEZAS NECESARIAS

INDICE	QUANT.
16	2

FERRAGEM NECESSÁRIA
HARDWARE REQUIRED
HERRAMIENTA NECESSARIA

INDICE	IMAGEM	QTDE
N		8
O		4
P		4
R		4

FERRAMENTAS NECESSÁRIAS
TOOL REQUIRED
HERRAMIENTA NECESSARIA

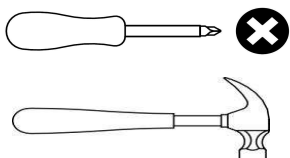

**Montagem do Vol-1 - Lateral Madeira
Assembly of Vol-1 - Wooden Side
Montaje de Vol-1 - Lateral de Madera**

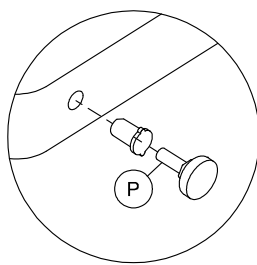
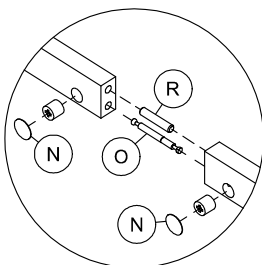
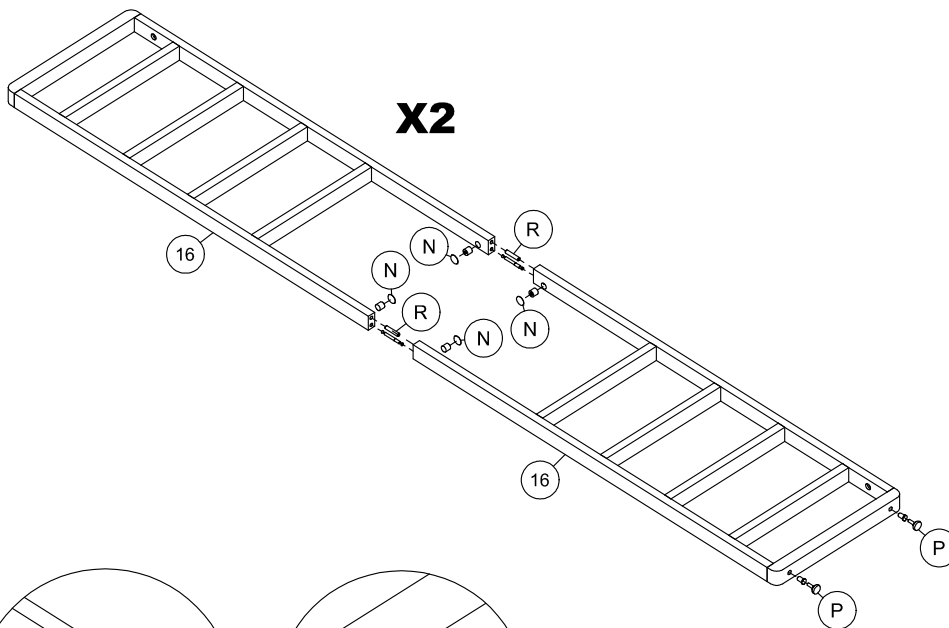

**PASSO 8
STEP 8
PASO 8**

PEÇAS NECESSÁRIAS
PARTS REQUIRED
PIEZAS NECESARIAS

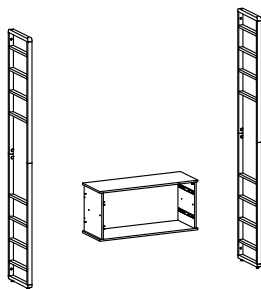

FERRAGEM NECESSÁRIA
HARDWARE REQUIRED
HERRAMIENTA NECESSARIA

INDICE	IMAGEM	QTDE
L		4

FERRAMENTAS NECESSÁRIAS
TOOL REQUIRED
HERRAMIENTA NECESSARIA

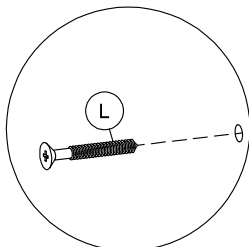
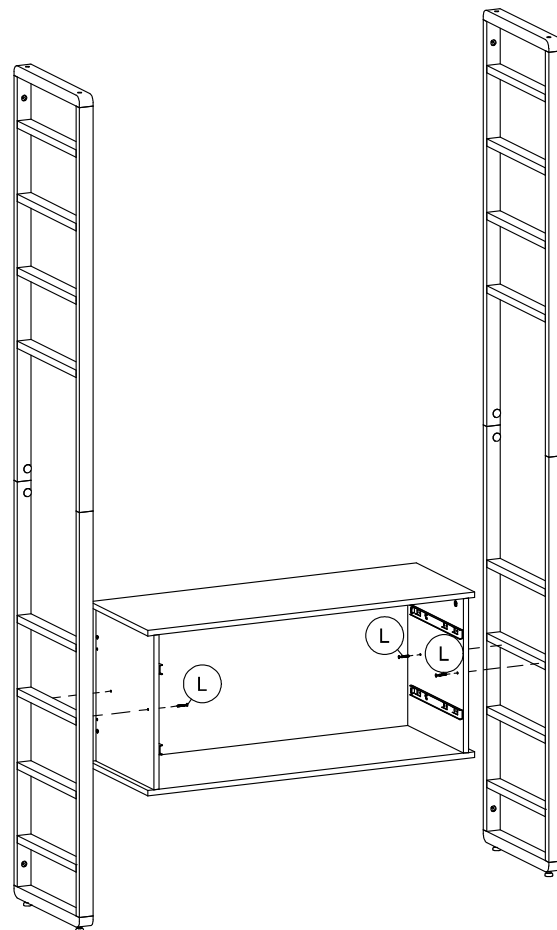
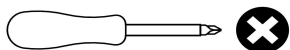

**PASSO 9
STEP 9
PASO 9**

PEÇAS NECESSÁRIAS
PARTS REQUIRED
PIEZAS NECESARIAS

INDICE	QUANT.
10	3

FERRAGEM NECESSÁRIA
HARDWARE REQUIRED
HERRAMIENTA NECESARIA

INDICE	IMAGEM	QTDE
E		12
F		2
J		4
K		12

FERRAMENTAS NECESSÁRIAS
TOOL REQUIRED
HERRAMIENTA NECESARIA

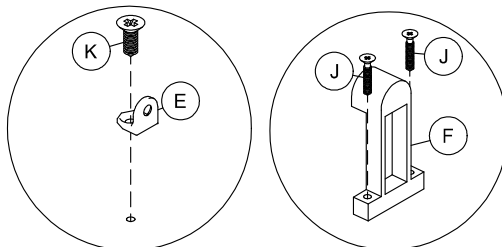
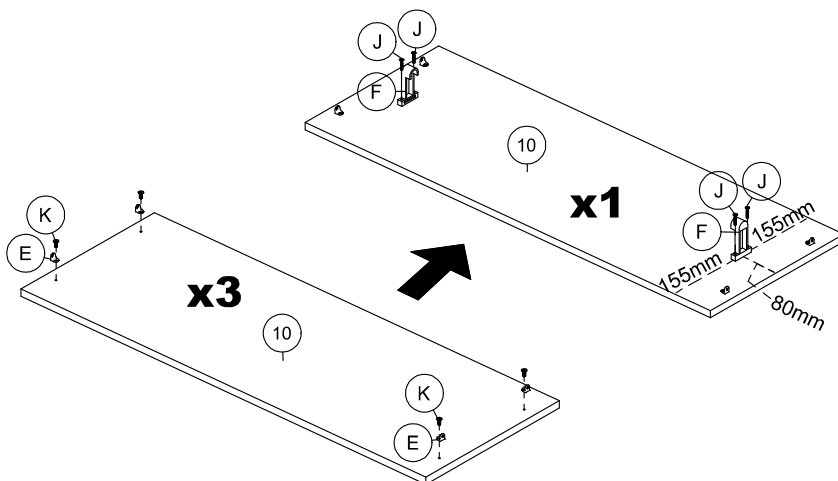
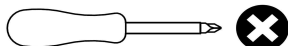

**PASSO 10
STEP 10
PASO 10**

PEÇAS NECESSÁRIAS
PARTS REQUIRED
PIEZAS NECESARIAS

INDICE	QUANT.
10	3

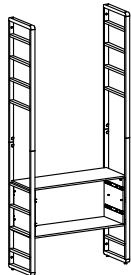

FERRAGEM NECESSÁRIA
HARDWARE REQUIRED
HERRAMIENTA NECESARIA

FERRAMENTAS NECESSÁRIAS
TOOL REQUIRED
HERRAMIENTA NECESARIA

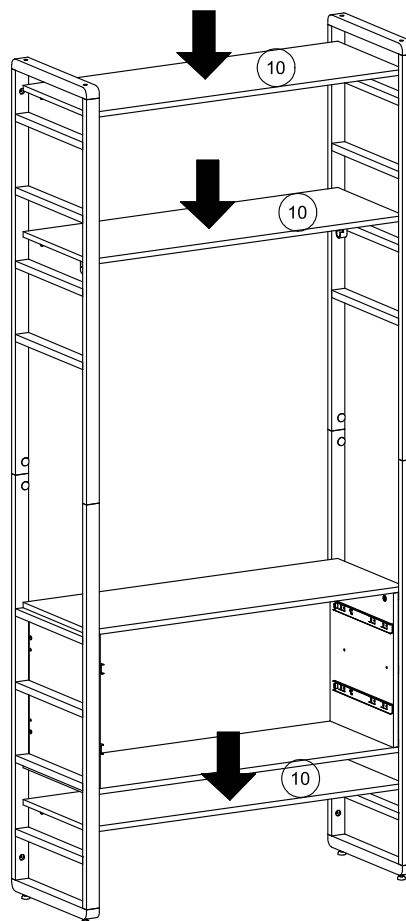

PASSO 11
STEP 11
PASO 11

PEÇAS NECESSÁRIAS
PARTS REQUIRED
PIEZAS NECESARIAS

INDICE	QUANT.
10	3

FERRAGEM NECESSÁRIA
HARDWARE REQUIRED
HERRAMIENTA NECESSARIA

INDICE	IMAGEM	QTDE
K		12

FERRAMENTAS NECESSÁRIAS
TOOL REQUIRED
HERRAMIENTA NECESSARIA

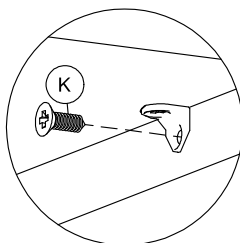
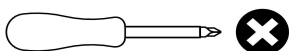

Fixação das prateleiras (10)
Fixing the shelves (10)
Fijación de las repisas.

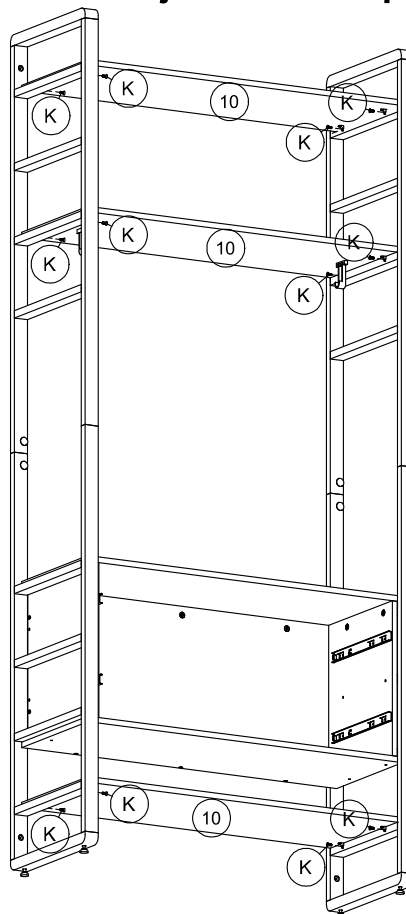



PASSO 12
STEP 12
PASO 12

PEÇAS NECESSÁRIAS
PARTS REQUIRED
PIEZAS NECESARIAS

INDICE	QUANT.
7	2
8	2
9	2

FERRAGEM NECESSÁRIA
HARDWARE REQUIRED
HERRAMIENTA NECESSARIA

INDICE	IMAGEM	QTDE
H		16
I		8

FERRAMENTAS NECESSÁRIAS
TOOL REQUIRED
HERRAMIENTA NECESSARIA

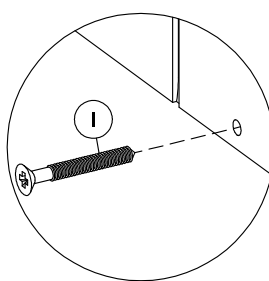
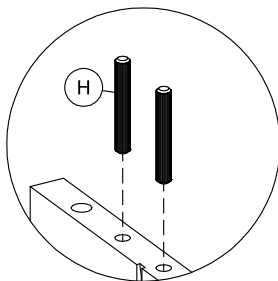
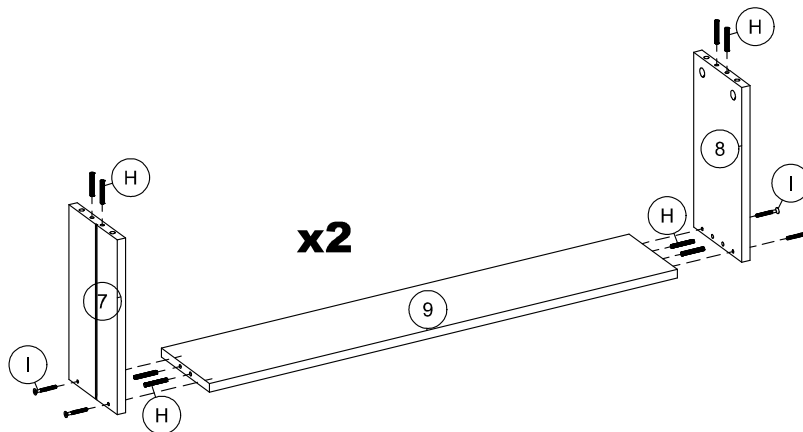
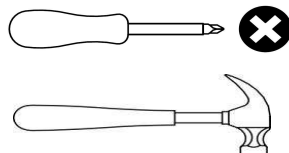

PASSO 13
STEP 13
PASO 13

PEÇAS NECESSÁRIAS
PARTS REQUIRED
PIEZAS NECESARIAS

INDICE	QUANT.
6	2

FERRAGEM NECESSÁRIA
HARDWARE REQUIRED
HERRAMIENTA NECESARIA

INDICE	IMAGEM	QTDE
A		8

FERRAMENTAS NECESSÁRIAS
TOOL REQUIRED
HERRAMIENTA NECESARIA

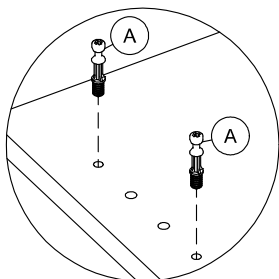
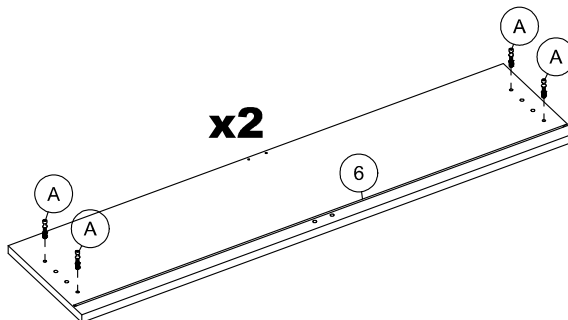
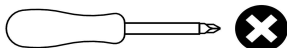

PASSO 14
STEP 14
PASO 14

PEÇAS NECESSÁRIAS
PARTS REQUIRED
PIEZAS NECESARIAS

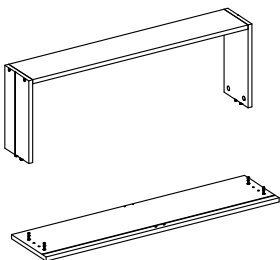

FERRAGEM NECESSÁRIA
HARDWARE REQUIRED
HERRAMIENTA NECESARIA

INDICE	IMAGEM	QTDE
B		4
G		4

FERRAMENTAS NECESSÁRIAS
TOOL REQUIRED
HERRAMIENTA NECESARIA

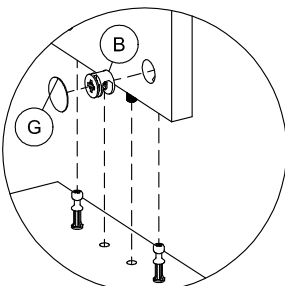
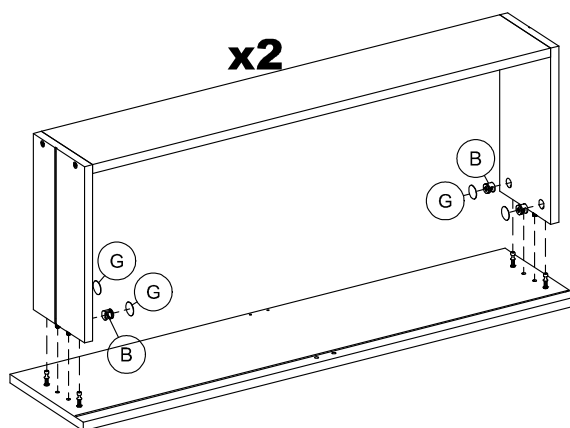
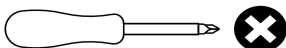

PASSO 15
STEP 15
PASO 15

PEÇAS NECESSÁRIAS
PARTS REQUIRED
PIEZAS NECESARIAS

INDICE	QUANT.
11	2

FERRAGEM NECESSÁRIA
HARDWARE REQUIRED
HERRAMIENTA NECESARIA

INDICE	IMAGEM	QTDE
21		28

FERRAMENTAS NECESSÁRIAS
TOOL REQUIRED
HERRAMIENTA NECESARIA

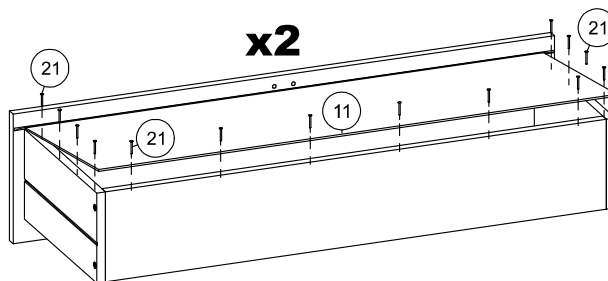
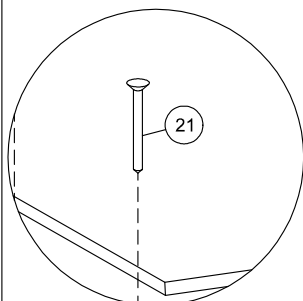
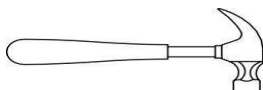



PASSO 16
STEP 16
PASO 16

PEÇAS NECESSÁRIAS
PARTS REQUIRED
PIEZAS NECESARIAS

INDICE	QUANT.
12	2
13	2

FERRAGEM NECESSÁRIA
HARDWARE REQUIRED
HERRAMIENTA NECESARIA

INDICE	IMAGEM	QTDE
H		4
K		8
L		4

FERRAMENTAS NECESSÁRIAS
TOOL REQUIRED
HERRAMIENTA NECESARIA

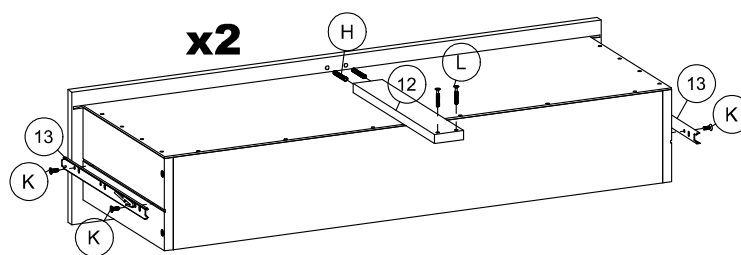
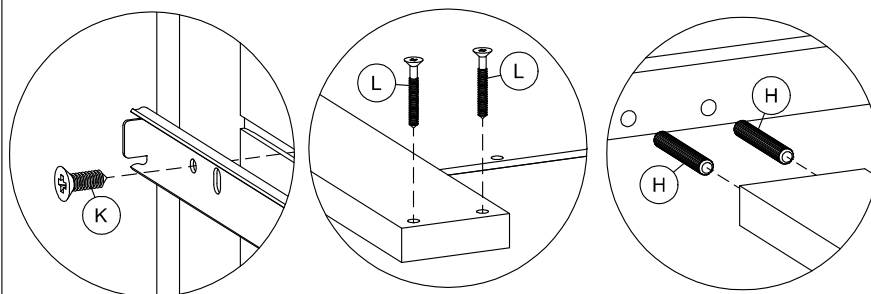
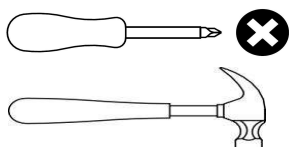

PASSO 17
STEP 17
PASO 17

PEÇAS NECESSÁRIAS
PARTS REQUIRED
PIEZAS NECESARIAS

INDICE	QUANT.
14	2

FERRAGEM NECESSÁRIA
HARDWARE REQUIRED
HERRAMIENTA NECESARIA

INDICE	IMAGEM	QTDE
K		4

FERRAMENTAS NECESSÁRIAS
TOOL REQUIRED
HERRAMIENTA NECESARIA

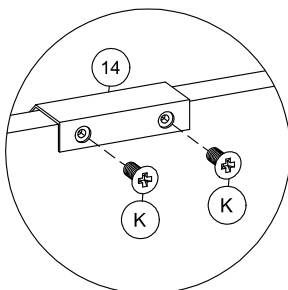
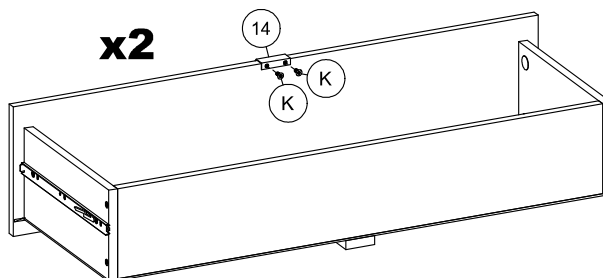
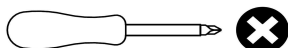

PASSO 18
STEP 18
PASO 18

PEÇAS NECESSÁRIAS
PARTS REQUIRED
PIEZAS NECESARIAS

INDICE	QUANT.
15	1

FERRAGEM NECESSÁRIA
HARDWARE REQUIRED
HERRAMIENTA NECESARIA

INDICE	IMAGEM	QTDE
D		4

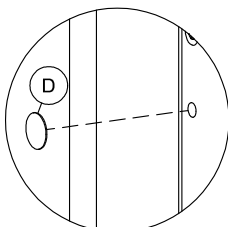
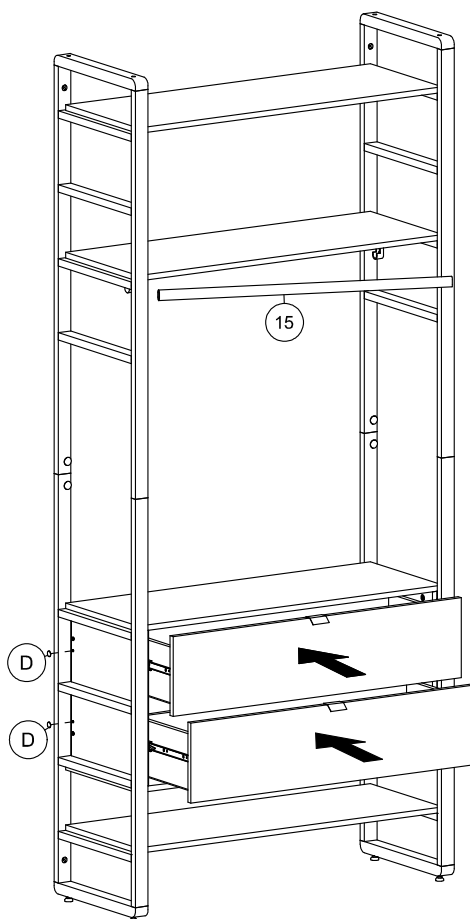

FERRAMENTAS NECESSÁRIAS
TOOL REQUIRED
HERRAMIENTA NECESARIA



PASSO 19
STEP 19
PASO 19

PEÇAS NECESSÁRIAS
PARTS REQUIRED
PIEZAS NECESSARIAS

FERRAGEM NECESSÁRIA
HARDWARE REQUIRED
HERRAMIENTA NECESSARIA

INDICE	IMAGEM	QTDE
M		4
N		4
Q		4

FERRAMENTAS NECESSÁRIAS
TOOL REQUIRED
HERRAMIENTA NECESSARIA

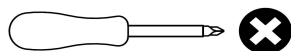

Fixação do móvel na parede.
Fixing the furniture to the wall.
Fijación de los muebles a la pared.

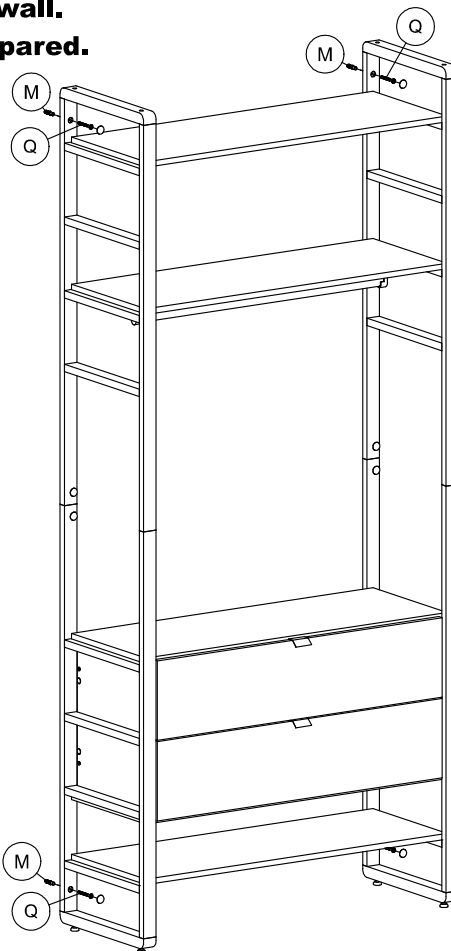

x4

