

**MÓDULO ROUPEIRO 2P BATER C PRAT / WARDROBE MODULE 2P BEAT C PLAT / MÓDULO ARMARIO 2P BEAT C PLAT  
PH-1766**

### Montagem

Recomenda-se a leitura prévia das instruções de montagem e profissionais especializados para montar.

### Assistência

Caso ocorra problema com algum dos componentes, sublinhe-o, identifique o problema e retorne esta relação, via fax ou outro meio de comunicação disponível para o representante.

-----  
Assinatura do cliente

### Assembly

Before the assembling is recommended to read carefully the assembly instruction by professional assemblers.

### Assistance

If happen problems with any component, underline the same, identify the problem and send back this relation immediately, by fax or other way.

-----  
Client signature

### Montaje

Se recomienda la lectura previa de las instrucciones de montaje y profesionales especializados para montarlos.

### Assistencia

Caso sucedan problemas con alguno de los componentes, subraye el componente, identifique el problema, y retorne esta copia via fax u otro medio de comunicación posible.

-----  
Assinatura del cliente

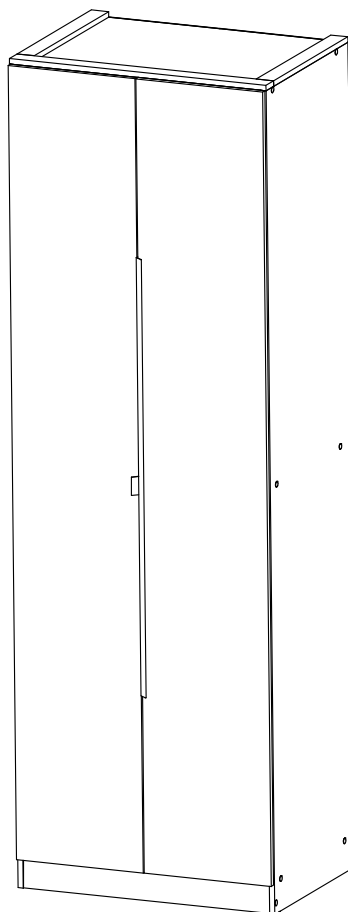

## Atenção / Attention / Atención

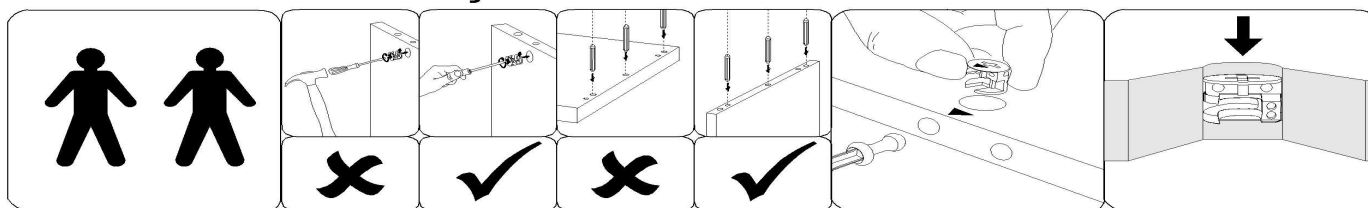

A Heval se reserva o direito de efetuar alterações nos produtos de suas linhas sem aviso prévio, quando entender necessário.

Herval reserves the right to effect modifications in the products, without previous advice, when understand necessary.

Herval se reserva el derecho de hacer las modificaciones que juzgue necesarias en sus productos, sin aviso previo, cuando lo crea necesario.

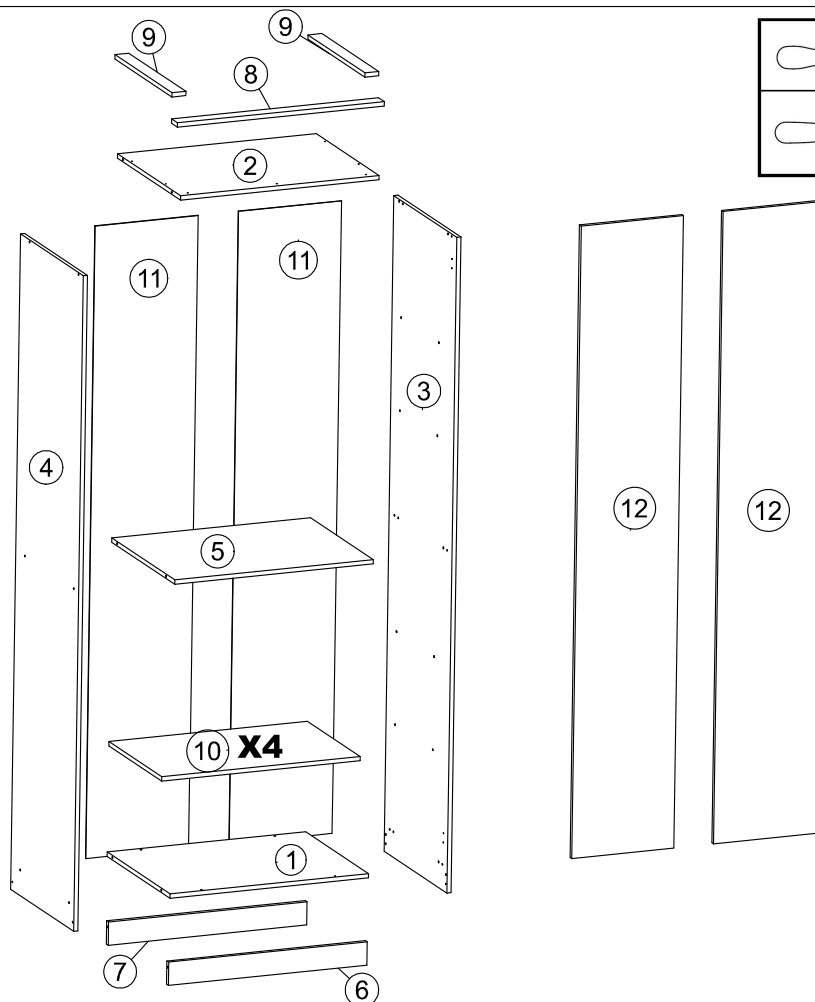

## LISTA DE PEÇAS / PARTS LIST / LISTA DE PIEZAS

### Volume 1 / Carton 1 / Caja 1

ÍNDICE / INDEX	CÓD. / CODE	PEÇA / PART / PIEZA	MED/MEASURE	QTDE / QUANT / CANT
1	159393E	BASE	713.0x535.0x15.0	1
2	159396E	TAMPO	713.0x535.0x15.0	1
3	159408E	LATERAL DIREITA	2255.0x535.0x15.0	1
4	159409E	LATERAL ESQUERDA	2255.0x535.0x15.0	1
5	159410E	PRATELEIRA FIXA	713.0x535.0x15.0	1
6	159399E	RODAPÉ FRONTAL	713.0x80.0x15.0	1
7	159400E	RODAPÉ TRASEIRO	713.0x80.0x15.0	1
8	159412E	MOLDURA FRONTAL	743.0x50.0x15.0	1
9	159401E	MOLDURA LATERAL	485.0x50.0x15.0	2
10	159411E	PRATELEIRA MÓVEL	713.0x450.0x15.0	4
13	1609336	PERFIL I 2145X20X3,8MM NOCE VERONA 180	2145.0x17.0x6.0	1
14	1609324	PUXADOR VERONA PINTADO 1200MM (PRETO PV097)	1200.0x37.3x20.2	1
15	1609323	PUXADOR VERONA PINTADO 50MM (PRETO PV097)	50.0x35.0x15.7	1
16	K072661-1768980	KIT 8 DOB RETA 35MM C/ AMORT	xx	1
17	K072683	KIT PH1766 ROUPEIRO 2P DE BATER C PRAT.	xx	1

### Volume 2 / Carton 2 / Caja 2

ÍNDICE / INDEX	CÓD. / CODE	PEÇA / PART / PIEZA	MED/MEASURE	QTDE / QUANT / CANT
11	159402E	FUNDO	2175.0x369.5x3.0	2
12	159403E	PORTA	2175.0x367.0x15.0	2

**LISTA DE ACESSÓRIOS / FITTINGS LIST / LISTA DE ACESSORIOS**

					<b>CÓD./ CODE: K000000</b>	
REF.	PEÇA	PART	PIEZA	QTDE	CÓDIGO	
A	TAPA FURO ADESIVO PAPEL 15mm	Hole Plug 15mm	Tapa Hueco 15mm	16	-	
B	SUORTE PRATELEIRA 7x6 (CINZA)	Shelf Support 7x6	Soporte Repisa 7x6	16	1604347	
C	CAVILHA DE MADEIRA 6x40	Dowel Ø6 x 40 mm	Tarugo Ø6 x 40 mm	16	1604742	
D	PARAFUSO 4 X 25 CAB. CHATA PHILIPS	Screw Ø4 x 25 mm	Tornillo Ø4 x 25 mm	11	1607862	
E	PARAFUSO 4 X 40 CAB. CHATA PHILIPS	Screw Ø4 x 40 mm	Tornillo Ø4 x 40 mm	16	1604937	
F	PARAFUSO 4 X 14 CAB. CHATA REBAIXADA PHILIPS	Screw Ø4 x 14 mm	Tornillo Ø4 x 14 mm	5	1602420	
G	PARAFUSO 3.5 X 40 CAB. CHATA PHILIPS	Screw Ø3.5 x 40 mm	Tornillo Ø3.5 x 40 mm	4	3,5x40	
G1	GIZ CERA NOG-CEDRO-FENDI-FREIJÓ Ø14x8MM	WAX CHALKS Ø14x8MM	TIZAS DE CERA Ø14x8MM	1	XXXXXXX	
G3	GIZ CERA GRAFITE - CINZA Ø14x8MM	WAX CHALKS Ø14x8MM	TIZAS DE CERA Ø14x8MM	1	XXXXXXX	
G4	GIZ CERA OFF WHITE - CINZA BP - LÍNEO Ø14x8MM	WAX CHALKS Ø14x8MM	TIZAS DE CERA Ø14x8MM	1	XXXXXXX	
H	PREGO 10 X 10 C/CABEÇA - Ø1,5 x 23mm	Nail 10 X 10 - Ø1,5 x 23mm	Clavo 10 X 10	67	1605365	
I	SAPATA L 19x17x8mm Ø2 (02.02.053)	Plastic Foot L 19x17x8mm Ø2mm	Pie de Plastico L 19x17x8mm Ø2mm	4	XXXXXXX	

**KIT DOBRADIÇAS / HINGES KIT / KIT BISAGRAS**

					<b>CÓD./ CODE: K000000</b>	
REF.	PEÇA	PART	PIEZA	QTDE	CÓDIGO	
F	PARAFUSO 4 X 14 CAB. CHATA REBAIXADA PHILIPS	Screw Ø4 x 14 mm	Tornillo Ø4 x 14 mm	24	1602420	
J	CALÇO DOB.BAIXA (4115412990)	LOW SHIMS	CUÑAS BAJAS	4	-	
K	DOB. BAIXA. AMORT 35MM (4115412990)	BAIXA HINGE WITH DAMPING	BISAGRA BAICA CON AMORTIGUACIÓN	4	4115412990	

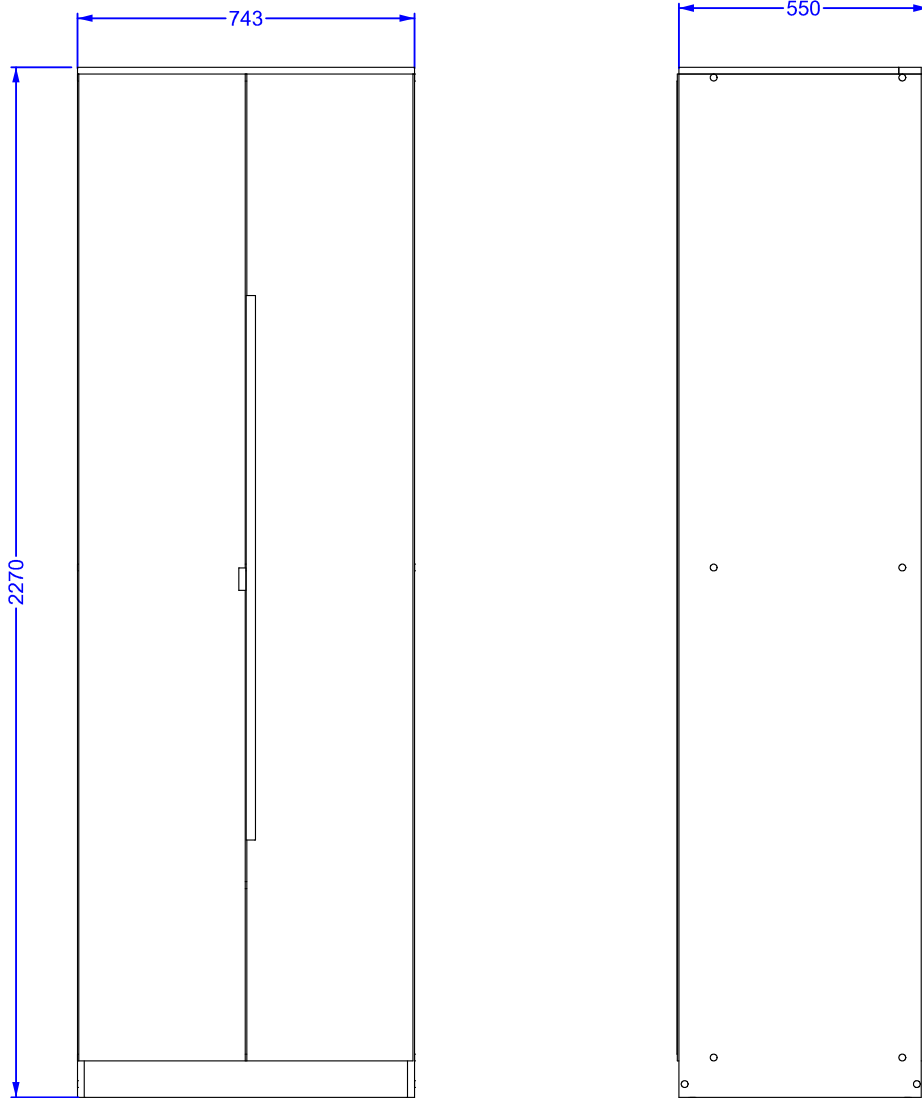

**PASSO 1**  
**STEP 1**  
**PASO 1**

PEÇAS NECESSÁRIAS  
PARTS REQUIRED  
PIEZAS NECESARIAS

INDICE	QUANT.
1	1
2	1
5	1
6	1
7	1

FERRAGEM NECESSÁRIA  
HARDWARE REQUIRED  
HERRAMIENTA NECESARIA

INDICE	IMAGEM	QTDE
C		24

FERRAMENTAS NECESSÁRIAS  
TOOL REQUIRED  
HERRAMIENTA NECESARIA

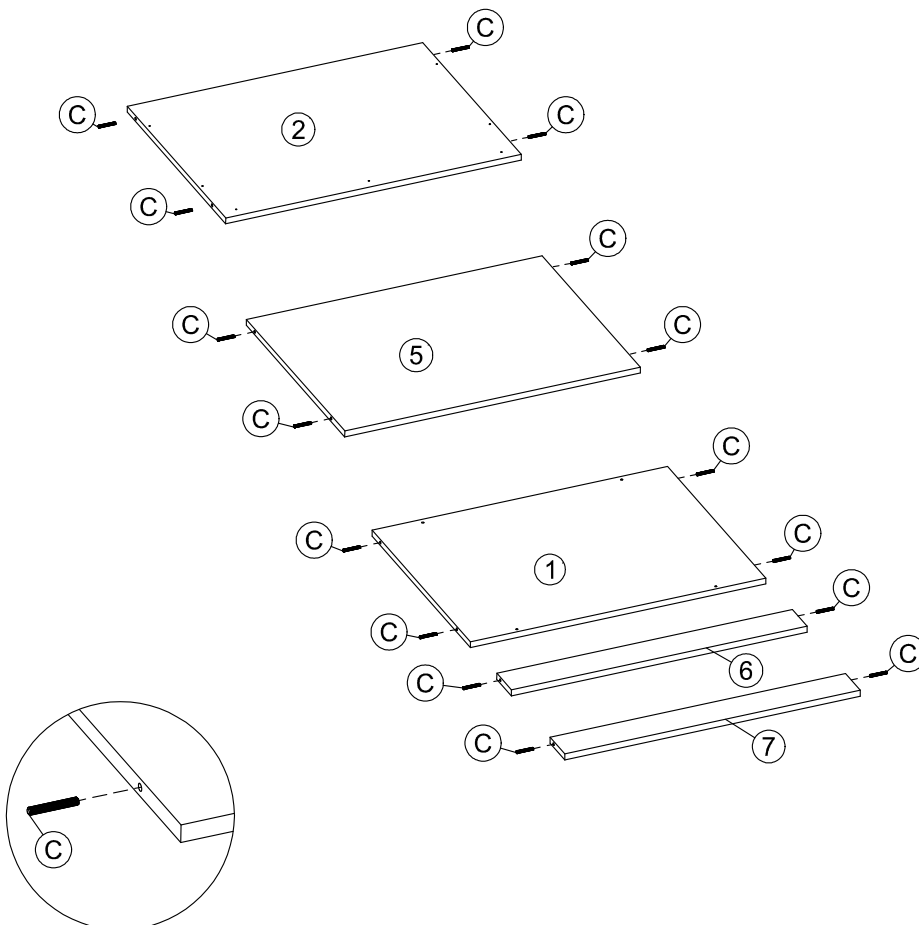
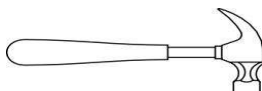



**PASSO 2**  
**STEP 2**  
**PASO 2**

PEÇAS NECESSÁRIAS  
PARTS REQUIRED  
PIEZAS NECESARIAS

INDICE	QUANT.
3	1
4	1

FERRAGEM NECESSÁRIA  
HARDWARE REQUIRED  
HERRAMIENTA NECESARIA

INDICE	IMAGEM	QTDE
H		4
I		4

FERRAMENTAS NECESSÁRIAS  
TOOL REQUIRED  
HERRAMIENTA NECESARIA

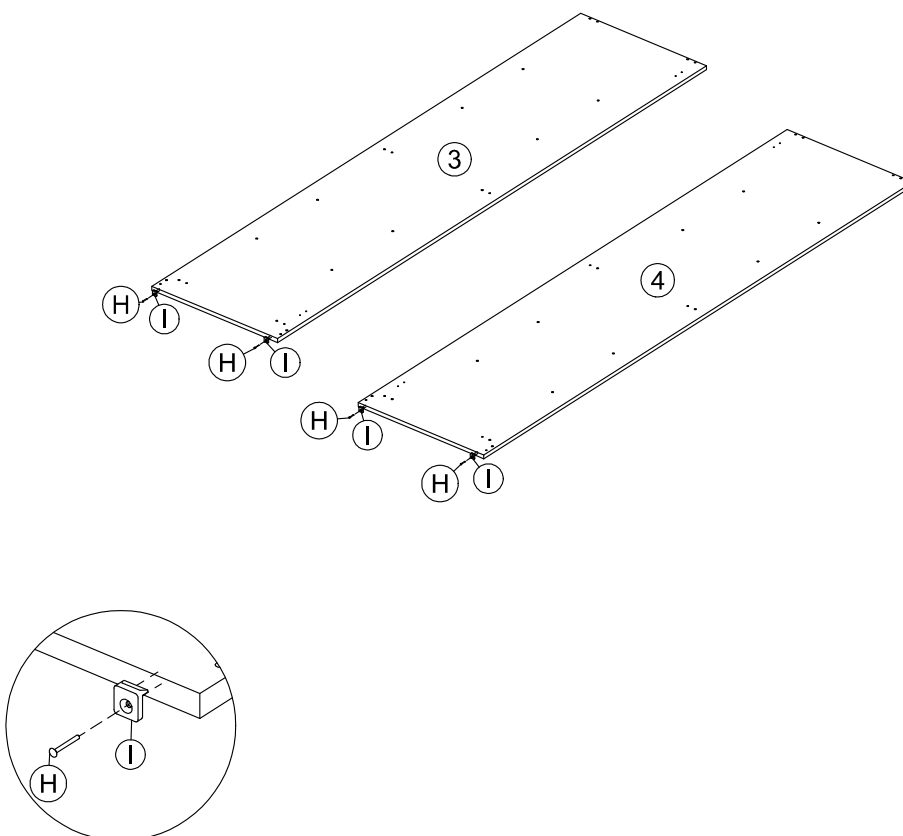
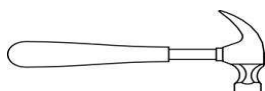

**PASSO 3  
STEP 3  
PASO 3**

PEÇAS NECESSÁRIAS  
PARTS REQUIRED  
PIEZAS NECESARIAS

INDICE	QUANT.
1	1
2	1
3	1
4	1
5	1
6	1
7	1

FERRAGEM NECESSÁRIA  
HARDWARE REQUIRED  
HERRAMIENTA NECESARIA

INDICE	IMAGEM	QTDE
E		41

FERRAMENTAS NECESSÁRIAS  
TOOL REQUIRED  
HERRAMIENTA NECESARIA

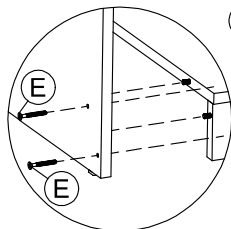
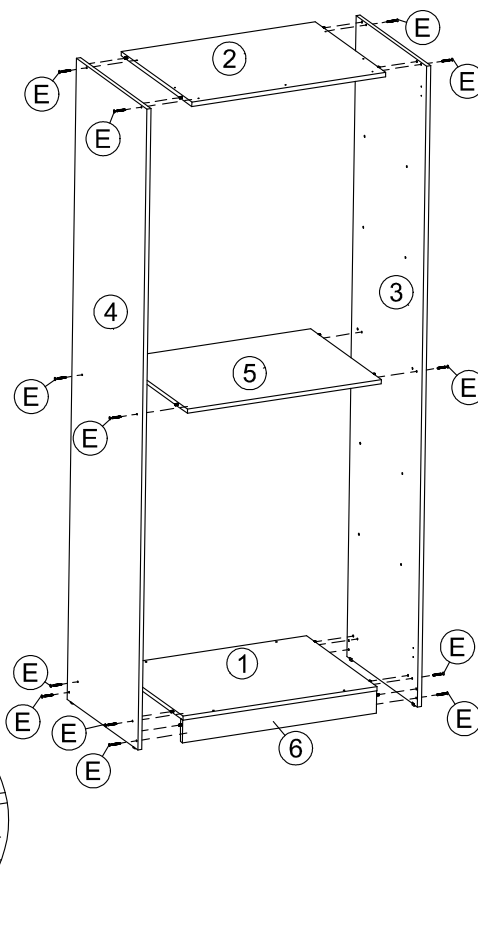
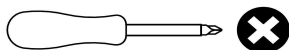



**PASSO 4  
STEP 4  
PASO 4**

PEÇAS NECESSÁRIAS  
PARTS REQUIRED  
PIEZAS NECESARIAS

INDICE	QUANT.
8	1
9	1

FERRAGEM NECESSÁRIA  
HARDWARE REQUIRED  
HERRAMIENTA NECESARIA

INDICE	IMAGEM	QTDE
D		7
G		4

FERRAMENTAS NECESSÁRIAS  
TOOL REQUIRED  
HERRAMIENTA NECESARIA

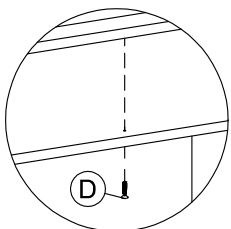
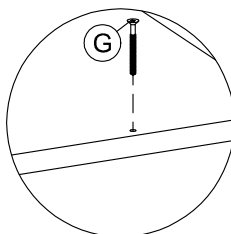
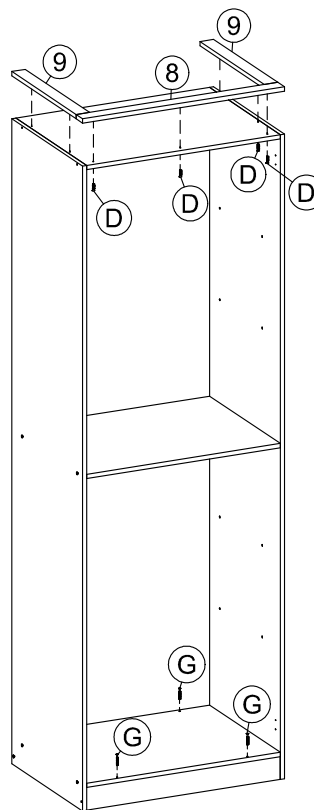
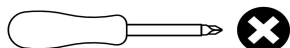

**PASSO 5  
STEP 5  
PASO 5**

PEÇAS NECESSÁRIAS  
PARTS REQUIRED  
PIEZAS NECESARIAS

INDICE	QUANT.
11	2

FERRAGEM NECESSÁRIA  
HARDWARE REQUIRED  
HERRAMIENTA NECESARIA

INDICE	IMAGEM	QTDE
H		67

FERRAMENTAS NECESSÁRIAS  
TOOL REQUIRED  
HERRAMIENTA NECESARIA

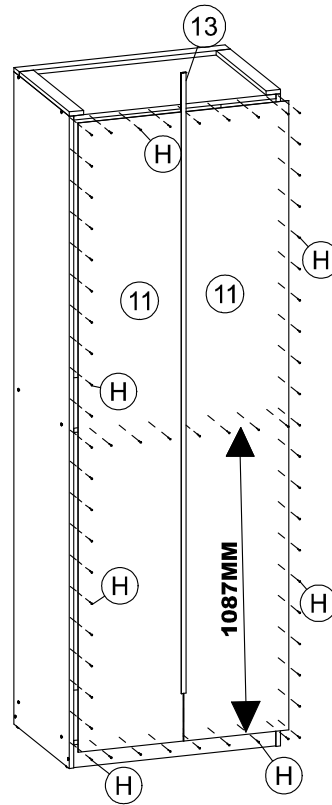
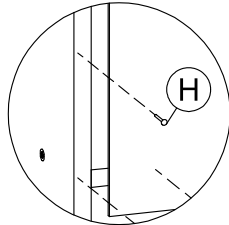
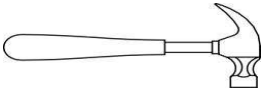

**PASSO 6  
STEP 6  
PASO 6**

PEÇAS NECESSÁRIAS  
PARTS REQUIRED  
PIEZAS NECESARIAS

---

FERRAGEM NECESSÁRIA  
HARDWARE REQUIRED  
HERRAMIENTA NECESARIA

INDICE	IMAGEM	QTDE
B		16

FERRAMENTAS NECESSÁRIAS  
TOOL REQUIRED  
HERRAMIENTA NECESARIA

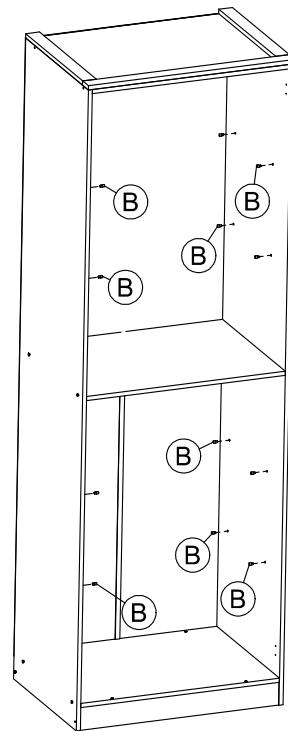
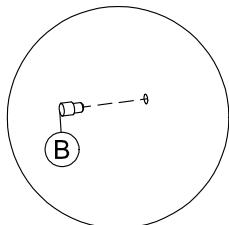
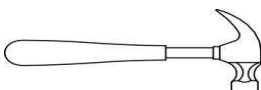

**PASSO 7  
STEP 7  
PASO 7**

PEÇAS NECESSÁRIAS  
PARTS REQUIRED  
PIEZAS NECESSARIAS

INDICE	QUANT.
10	4

FERRAGEM NECESSÁRIA  
HARDWARE REQUIRED  
HERRAMIENTA NECESSARIA

FERRAMENTAS NECESSÁRIAS  
TOOL REQUIRED  
HERRAMIENTA NECESSARIA

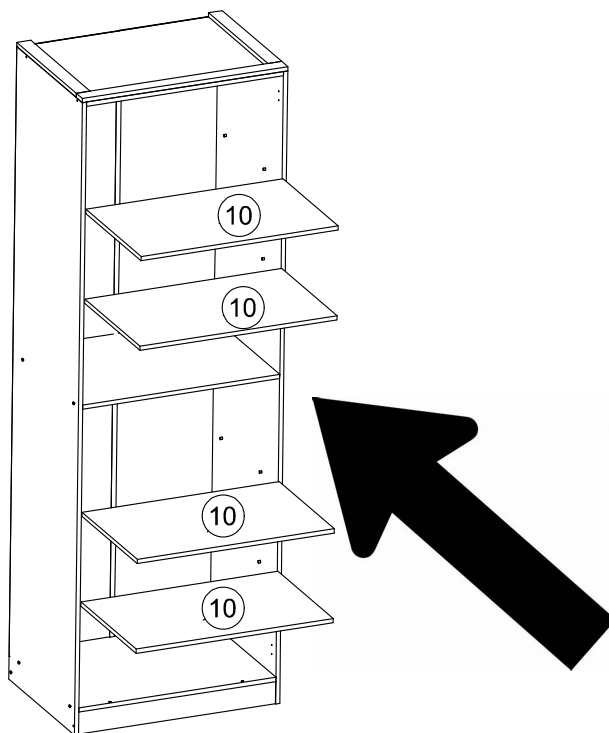
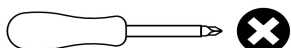

**PASSO 8  
STEP 8  
PASO 8**

PEÇAS NECESSÁRIAS  
PARTS REQUIRED  
PIEZAS NECESSARIAS

INDICE	QUANT.
12	1

FERRAGEM NECESSÁRIA  
HARDWARE REQUIRED  
HERRAMIENTA NECESSARIA

INDICE	IMAGEM	QTDE
F		16
K		8

FERRAMENTAS NECESSÁRIAS  
TOOL REQUIRED  
HERRAMIENTA NECESSARIA

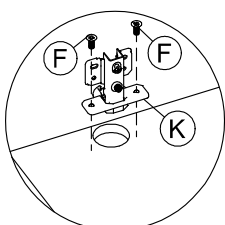
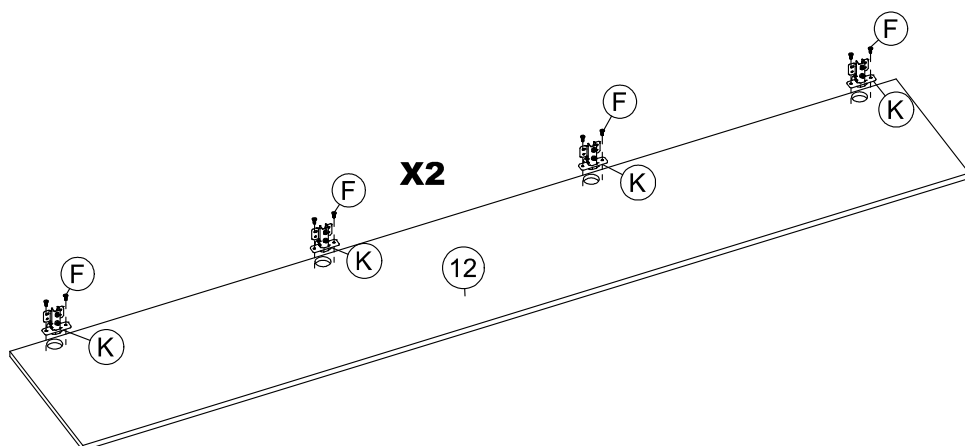
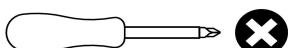

**PASSO 9**  
**STEP 9**  
**PASO 9**

PEÇAS NECESSÁRIAS  
 PARTS REQUIRED  
 PIEZAS NECESSARIAS

INDICE	QUANT.
14	1
15	1

FERRAGEM NECESSÁRIA  
 HARDWARE REQUIRED  
 HERRAMIENTA NECESSARIA

INDICE	IMAGEM	QTDE
F		53

FERRAMENTAS NECESSÁRIAS  
 TOOL REQUIRED  
 HERRAMIENTA NECESSARIA

