

**Lista de ferragens
Hardware list
Lista de materiales**

A		CAVILHA Ø6X30 CLAVIJA Ø6X30 WOOD DOWEL Ø6X30	08
C		PARAFUSO CC 3,5X40 TORNILLO CC 3,5X40 SCREW CC 3,5X40	04
U		ADESIVO TAPA FURO ADHESIVO STICKER	04
M		PREGO 10X10 CLAVO 10X10 NAIL	25
Z		PARAFUSO CF 3,5X30 TORNILLO CF 3,5X30 SCREW CF 3,5X30	06

Lista de peças / Parts lists / Lista de piezas

REF	DESC	COMP	LARG	ESP	QTD.
IS1650-01	LATERAL DIREITA/LADO DERECHO/RIGHT SIDE	225	150	25	1
IS1650-02	LATERAL ESQUERDA/LADO IZQUIERDO/LEFT SIDE	225	150	25	1
IS1650-03	BASE/BASE/BASE	1149	150	25	2
IS1650-61	COSTA/FONDO/BACK	1196	220	03	1

**FERRAMENTAS NECESSÁRIAS:
HERRAMIENTAS NECESARIAS:
NECESSARY TOOLS:**

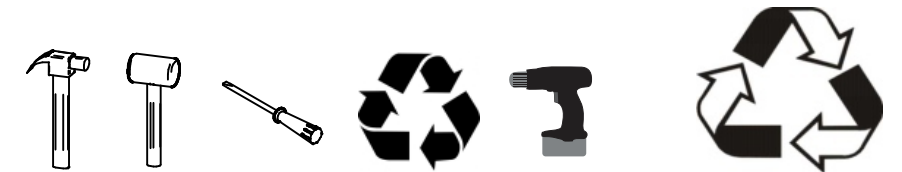

**"IMPORTANTE LER COM ATENÇÃO
E GUARDAR PARA EVENTUAIS
CONSULTAS".**

**"IMPORTANTE LEER CON ATENCIÓN Y GUARDAR PARA
EVENTUALES CONSULTAS".**

**"IMPORTANT TO READ CAREFULLY AND SAVE FOR ANY
QUERIES".**

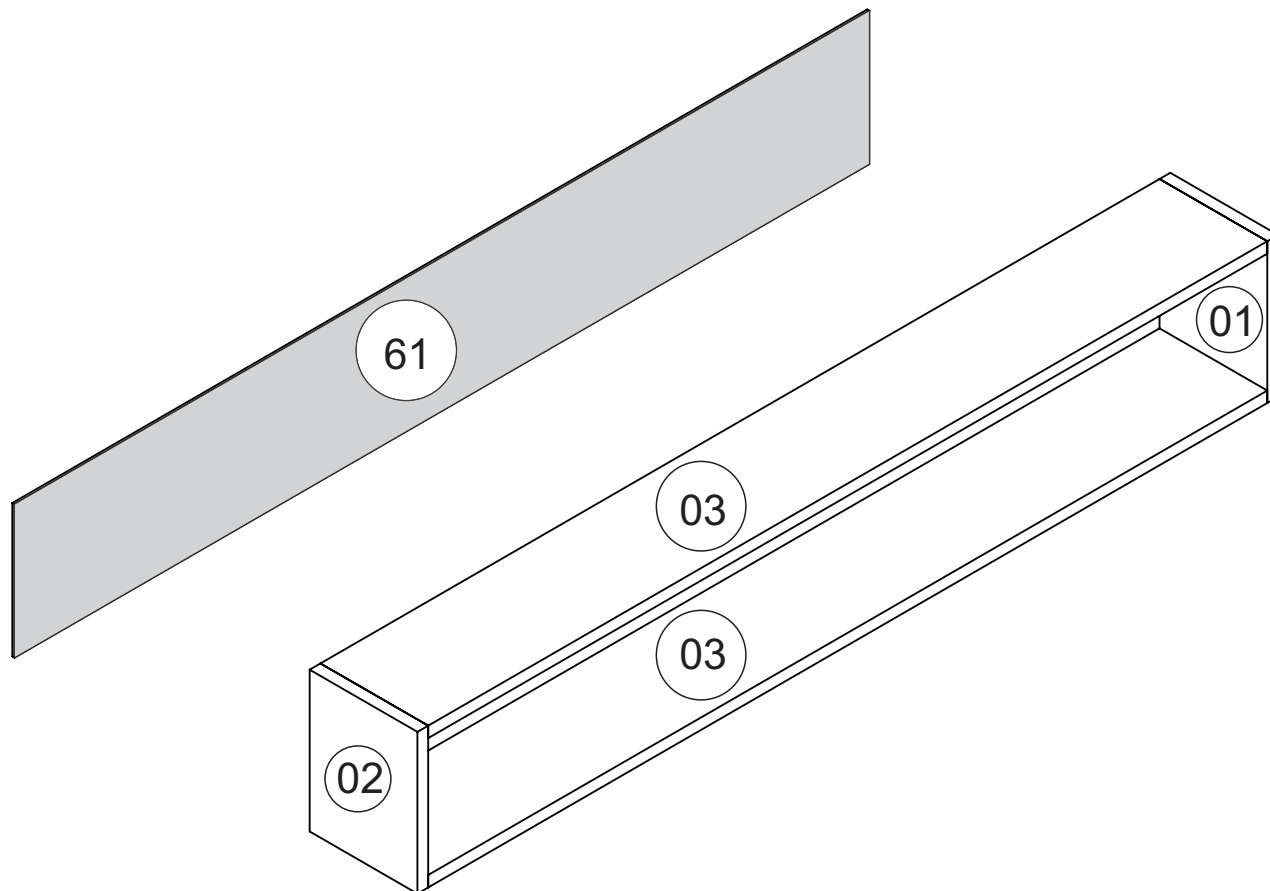

01

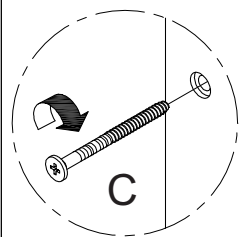
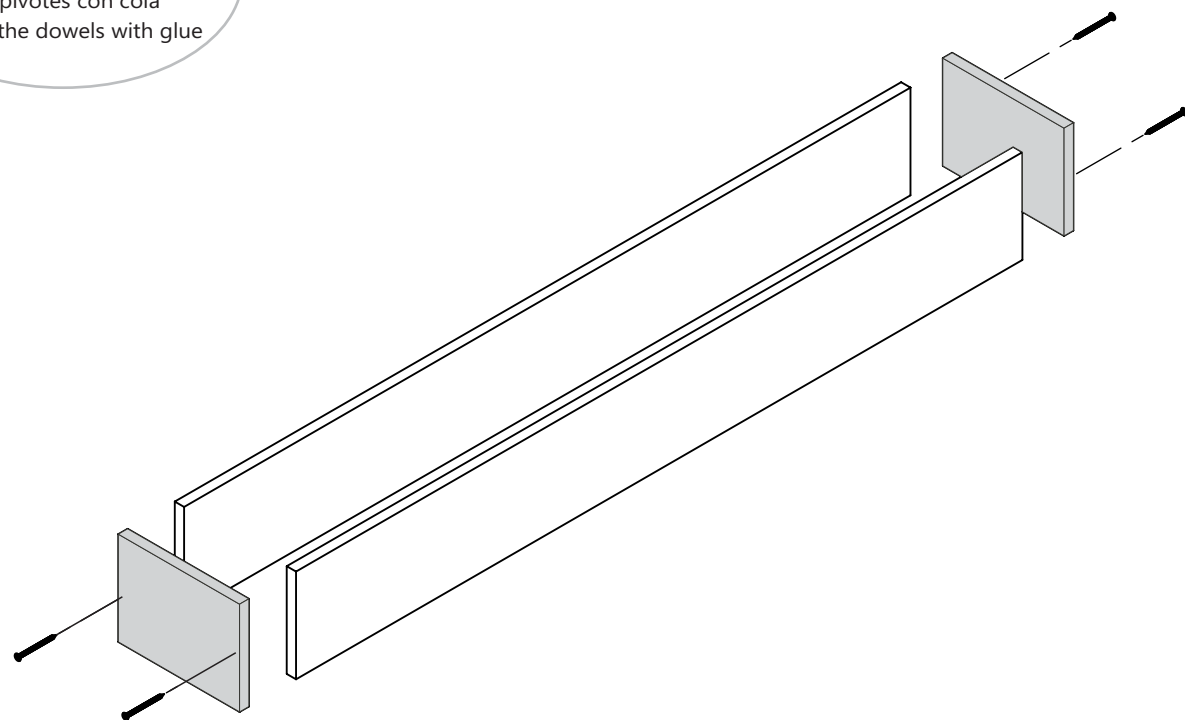
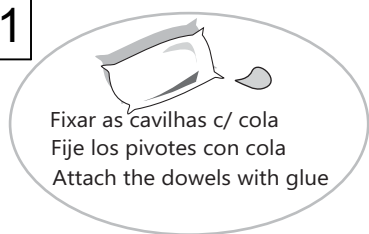

02

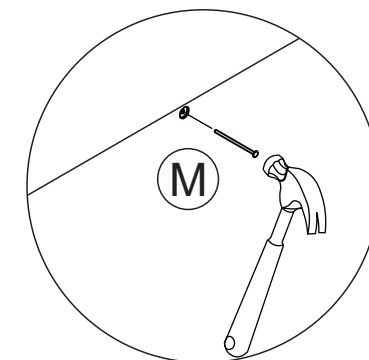
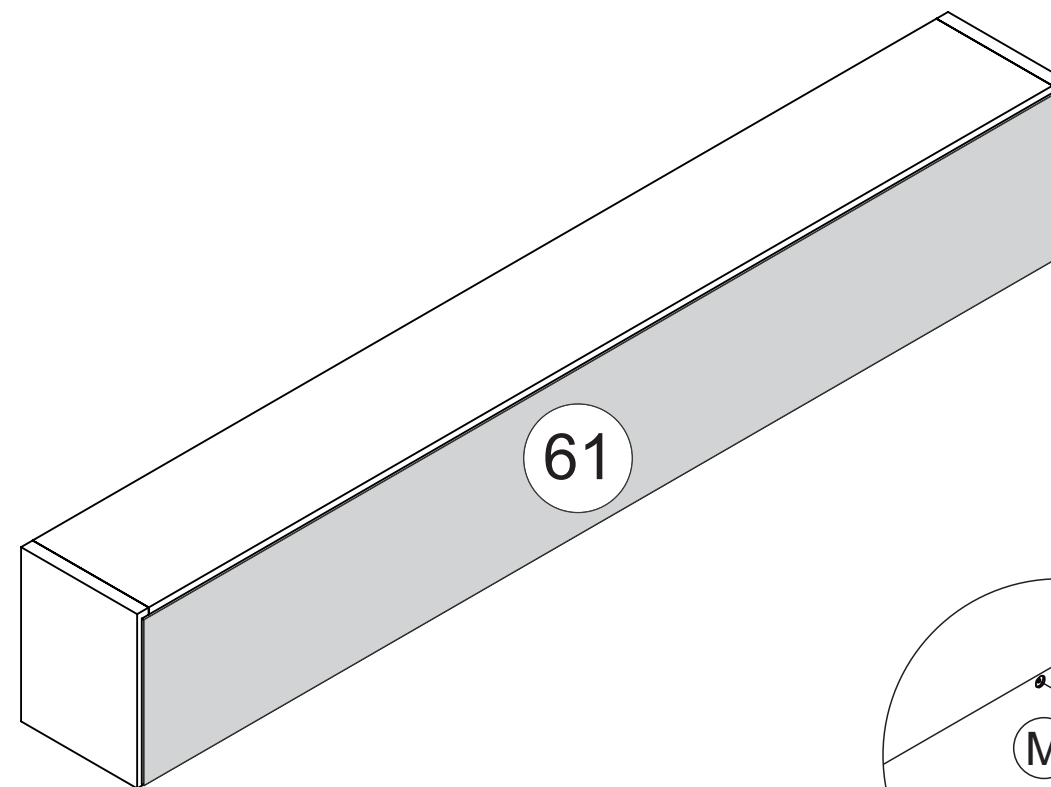

03

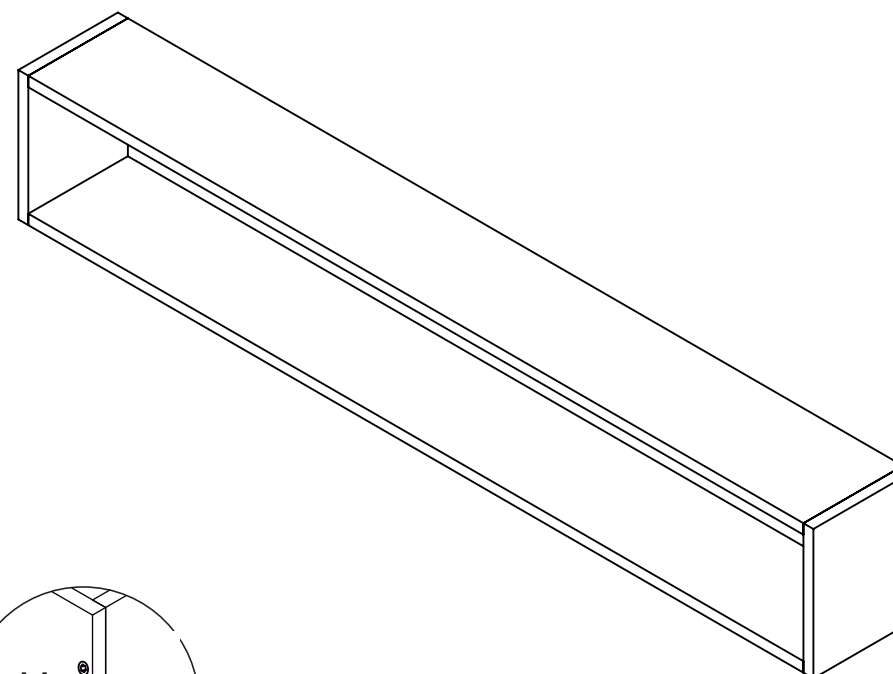
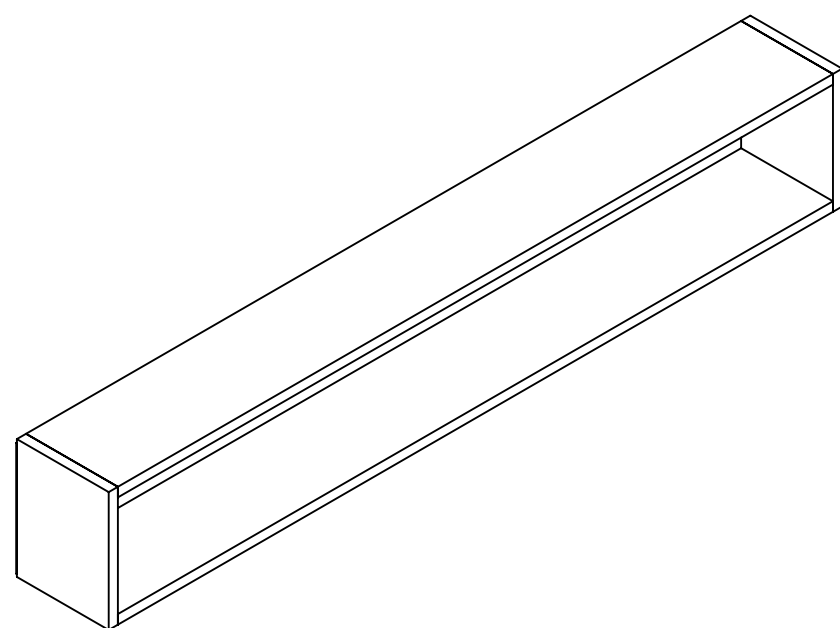

Parafuso "Z" união de módulos
Tornillo "Z" unión de módulos

