

Produto Concluído  
Producto terminado  
Finished Product

ITM/D311-  
Rev 000

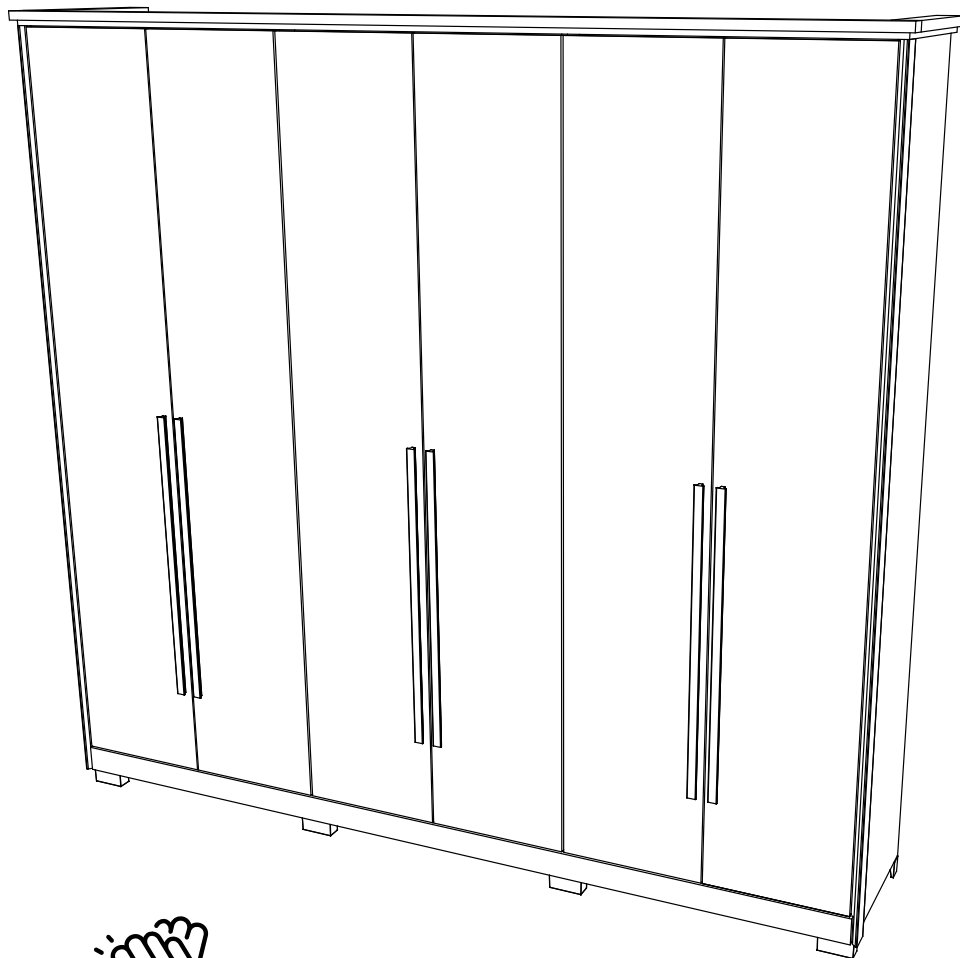

**HENN**

Ind. e Com. de Móveis Henn  
Mondai - SC - Brasil

+55 49 3674.3500

@moveishenn  
www.henn.com.br

ITM/D311-  
**INSTRUÇÕES DE  
MONTAGEM**

INSTRUCCIONES DE MONTAJE  
ASSEMBLY INSTRUCTIONS

Roupeiro Verona 6 Portas 6 Gavetas | Armario Verona 6 Puertas 6 Cajones |  
Wardrobe Verona 6 Doors 6 Drawers

D311-129 OFF White/Nature  
D311-130 Castanho HP II  
D311-198 Jequitibá Brilho

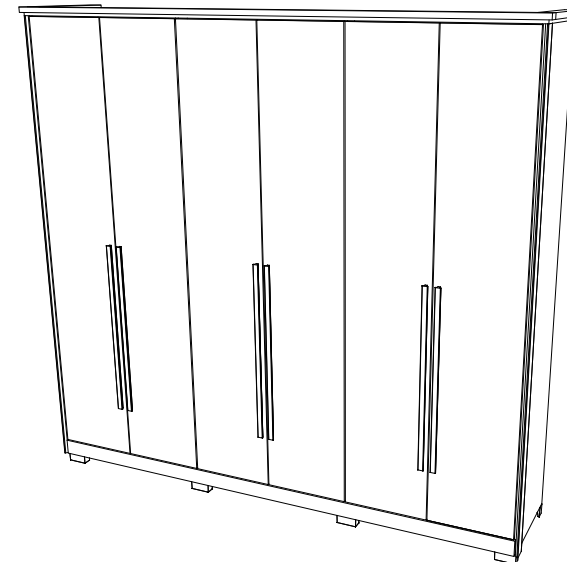

Requisitos para montagem  
Requisitos para la montaje  
Assembly Requirements

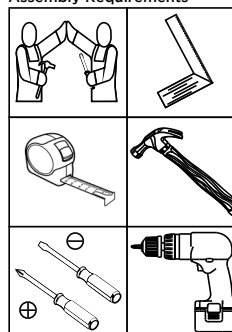

Imagens meramente ilustrativas,  
não acompanha o produto.  
Imágenes ilustrativas, no incluidas  
con el producto.  
Illustrative images, not included  
with the product.

**AVISO**

Para limpeza de seu móvel, use uma flanela seca ou umedecida, e não utilize produtos químicos que possam danificar seu produto.

**SISTEMA DE MONTAGEM**

O sistema de montagem dos produtos, funciona de acordo com a ordem crescente dos números indicados no desenho. Ex: 01, 02, 03, 04... até a conclusão da montagem.

**ASSISTÊNCIA TÉCNICA**

Para solicitação de Assistência Técnica você consumidor deverá entrar em contato com o Lojista a qual você realizou a compra deste produto e solicitar a assistência técnica das peças avariadas. A garantia abrange todas as peças, partes e componentes que eventualmente venham apresentar defeito de fabricação no prazo de 03 (três) meses, contando a partir da entrega do produto ao consumidor, mediante nota fiscal de compra. Se houver qualquer alteração na estrutura do produto ou ocorrer defeito por negligência do montador/consumidor em relação a instrução de montagem e manuseio, não será fornecido assistência técnica gratuita.

**ADVERTENCIA**

Para limpeza de su móvil, use una flanela seca o húmeda, y no utilice productos químicos que puedan dañar su producto.

**SISTEMA DE MONTAJE**

El sistema de montaje de los productos funciona de acuerdo con el orden creciente de los números indicados en el dibujo. Ej: 01, 02, 03, 04... hasta la conclusión del montaje.

**ASISTENCIA TÉCNICA**

Para solicitar Asistencia Técnica, el consumidor debe comunicarse con el Comercio que usted realizó la compra de este producto y solicita asistencia técnica para las partes dañadas. La garantía cubre todas las partes, piezas y componentes que eventualmente puedan presentar defecto de fabricación en el plazo de 03 (tres) meses, contados a partir de la entrega del producto al consumidor, mediante factura de compra. Si se produce algún cambio en la estructura del producto o se produce un defecto por negligencia del montador/consumidor en relación con las instrucciones de montaje y manipulación, no se prestará asistencia técnica gratuita.

**NOTICE**

To clean your furniture, use a dry or wet cloth, and do not use chemicals that may damage your product.

**ASSEMBLY SYSTEM**

The products' assembly system works according to the increasing order of the indicated numbers. For example: 01, 02, 03, 04 ... to the end of the assembly.





**TECHNICAL ASSISTANCE**

To request Technical Assistance, the consumer must contact the retailer from whom you purchased this product and request technical assistance for the damaged parts. The warranty covers all parts, parts and components that may eventually present a manufacturing defect within a period of 03 (three) months, counting from the delivery of the product to the consumer, by means of a purchase invoice. If there is any change in the structure of the product or defect occurs due to negligence of the assembler/consumer in relation to the assembly and handling instruction, free technical assistance will not be provided.



ACESSÓRIOS REQUERIDOS

FERRAMENTAS NECESSÁRIAS

E		40
J		08
R		08
W		04
AH		08

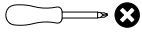

4x

4º

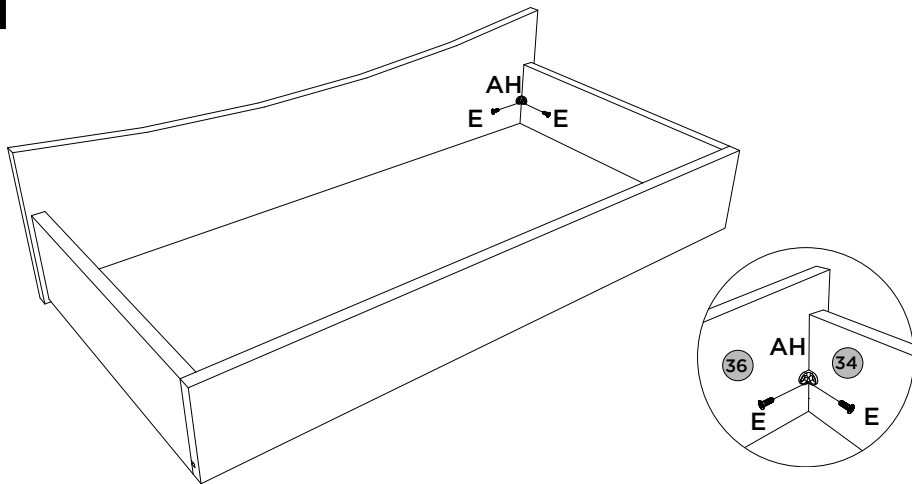





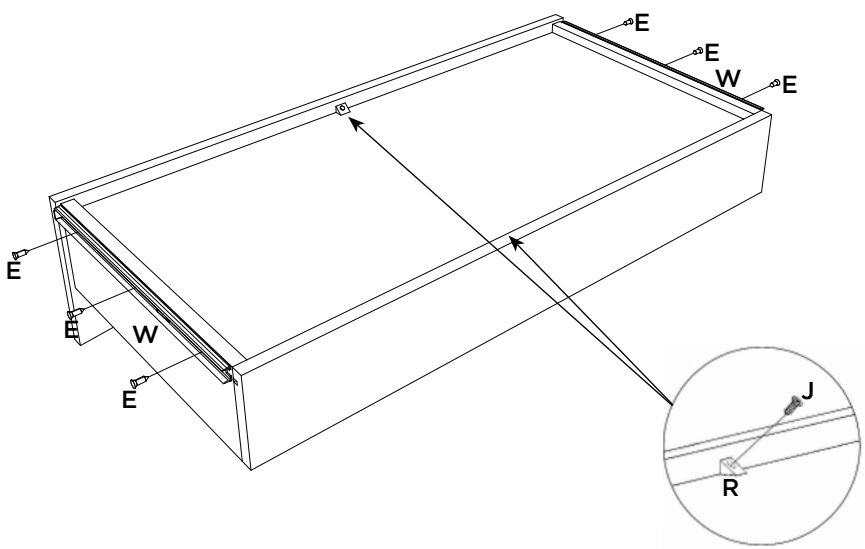

4x

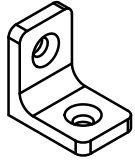
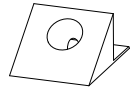
5º

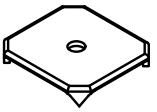
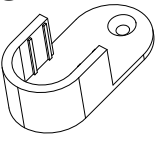
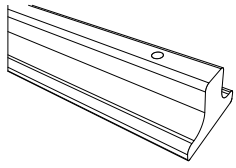
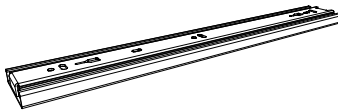
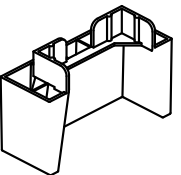
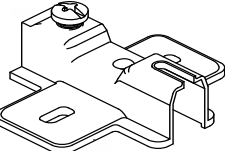
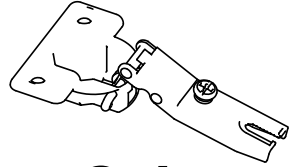

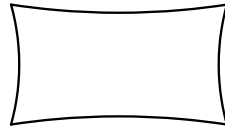
ACESSÓRIOS | ACCESORIOS | ACCESSORIES

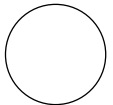
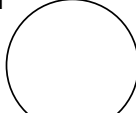
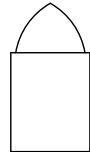
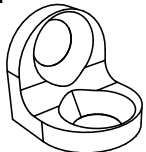
<p><b>Q</b></p>  <p><b>x4</b></p>	<p><b>R</b></p>  <p><b>x12</b></p>	<p><b>S</b></p>  <p><b>x204</b></p>	<p><b>T</b></p>  <p><b>x55</b></p>	<p><b>U</b></p>  <p><b>x4</b></p>		
<p><b>V</b></p>  <p><b>x6</b></p>	<p><b>W</b></p>  <p><b>x6 PAR</b></p>	<p><b>X</b></p>  <p><b>x8</b></p>	<p><b>Y</b></p>  <p><b>x24</b></p>	<p><b>Z</b></p>  <p><b>x24</b></p>	<p><b>AA</b></p>  <p><b>x3</b></p>	
<p><b>AB</b></p>  <p><b>x2</b></p>	<p><b>AC</b></p>  <p><b>x3</b></p>	<p><b>AD</b></p>  <p><b>x1</b></p>	<p><b>AE</b></p>  <p><b>x58</b></p>	<p><b>AF</b></p>  <p><b>x6</b></p>	<p><b>AG</b></p>  <p><b>x2</b></p>	<p><b>AH</b></p>  <p><b>x12</b></p>

# LISTA DE PEÇAS | LISTA DE PIEZAS | LIST OF PIECES



Item	Caixa Caja Box	Qtd Ctd Qty	Descrição Descripción Description	Dimensões (mm)   Dimensiones (mm)   Dimensions (mm)		
				Comprimento Largo Length	Largura Ancho Width	Espesura Grosor Thickness
1	4/5	01	RODAPÉ FRONTAL   FALDÓN DELANTERO   FRONT SKIRTING	2469	73	15
2	2/5	02	TRAVESSA DO RODAPÉ   PLACA DE RODAPIÉ   SKIRTING PLATE	467	73	15
3	4/5	01	RODAPÉ TRASEIRO   REPOSAPIÉS TRASERO   BACK FOOTBOARD	2469	73	15
4	4/5	01	MOLDURA FRONTAL INFERIOR   MARCO FRONTAL INFERIOR   LOWER FRONT FRAME	2479	78	15
5	4/5	01	BASE   BASE   BASE	2469	500	15
6	2/5	01	LATERAL ESQUERDA   LATERAL IZQUIERDA   LEFT SIDE	2310	500	15
7	3/5	01	DIVISÃO ESQUERDA   DIVISIÓN IZQUIERDA   LEFT	1793	500	15
8=14	1/5	01	TAMPO DAS GAVETAS   TAPA DE LOS CAJONES   TOP OF DRAWERS	813	400	15
9=15	1/5	01	DIVISÃO SUPERIOR   DIVISÓN SUPERIOR   UPPER DIVISION	1038	355	15
10=16	2/5	04	PRATELEIRA   ESTANTE   SHELF	399	350	15
11	3/5	01	DIVISÃO DIREITA   DIVISIÓN DERECHA   RIGHT DIVISION	1793	500	15
12	2/5	01	PRATELEIRA DO CALCEIRO   ESTANTE DE CALCEIRO   CALCEIRO'S SHELF	813	250	15
13	2/5	01	LATERAL DIREITA   LADO DERECHO   RIGHT SIDE	2310	500	15
14=8	1/5	01	TAMPO DAS GAVETAS   TAPA DE LOS CAJONES   TOP OF DRAWERS	813	400	15
15=9	1/5	01	DIVISÃO SUPERIOR   DIVISÓN SUPERIOR   UPPER DIVISION	1038	355	15
16=10	2/5	04	PRATELEIRA   ESTANTE   SHELF	399	350	15
17	3/5	01	CHÃO DO MALEIRO   REPISA SUPERIOR   FLOOR OF MALEIRO	2469	500	15
18	3/5	02	RIPA DO MALEIRO   TRAVESAÑO SUPERIOR   MALEIRO'S LATH	414	73	15
19	4/5	01	TAMPO SUPERIOR   TAPA SUPERIOR   TOP PANEL	2529	520	15
20	2/5	02	MOLDURA LATERAL   MARCO LATERAL   LATERAL FRAME	2310	60	15
21	4/5	04	RIPA LATERAL   RIPA LATERAL   SIDE CLAPBOARD	505	58	25
22	4/5	02	MOLDURA LATERAL SUPERIOR   MARCO LATERAL SUPERIOR   TOP SIDE FRAME	475	70	25
23	4/5	01	MOLDURA FRONTAL SUPERIOR   MARCO FRONTAL SUPERIOR   UPPER FRONT FRAME	2559	60	25
24	4/5	01	FUNDO SUPERIOR   FONDO TOP   TOP FUND	2487	435	3
25	3/5	06	FUNDO   FONDO   BOTTOM	1813	411	3
26	5/5	06	PORTA   PUERTA   DOOR	2224	410	15
27	1/5	02	RIPA DE TRÁS MENOR     SMALLER BACK SLAT   TABLILLA TRASERA MÁS PEQUEÑA	743	90	15
28	2/5	04	LADO DE GAVETA MENOR   LADO DEL CAJÓN MÁS PEQUEÑO   SMALLER DRAWER SIDE	350	90	15
29=35	4/5	02	FUNDO DE GAVETA RECORTADO   FONDO DEL CAJÓN RECORTADO   CROPPED DRAWER BOTTOM	724	361	3
30	1/5	02	FRENTE DE GAVETA MENOR   FRENTE DE CAJÓN MÁS PEQUEÑO   SMALLER DRAWER FRONT	755	106	15
31	4/5	02	DIVISÓRIA MAIOR   DIVISOR MÁS GRANDE   LARGER DIVIDER	712	60	9
32	4/5	04	DIVISÓRIA MENOR   DIVISOR MÁS PEQUEÑO   SMALLER DIVIDER	349	60	9
33	1/5	04	RIPA DE TRÁS   MALLA DETRÁS   REAR LAHT	743	110	15
34	2/5	08	LADO DE GAVETA   LADO DEL CAJÓN   SIDE OF DRAWER	350	110	15
35=29	4/5	04	FUNDO DE GAVETA RECORTADO   FONDO DEL CAJÓN RECORTADO   CROPPED DRAWER BOTTOM	724	361	3
36	4/5	04	FRENTE DE GAVETA COM USINAGEM   FRENTE DE CAJÓN CON MECANIZADO   DRAWER FRONT WITH MACHINING	755	192	15

## PASSO 22

### PEÇAS REQUERIDAS

35	FUNDO DE GAVETA RECORTADO	x4
36	FRENTE DE GAVETA COM USINAGEM	x4

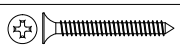
### ACESSÓRIOS REQUERIDOS

I		08
AC		

### FERRAMENTAS NECESSÁRIAS

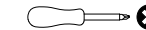

4x

2º

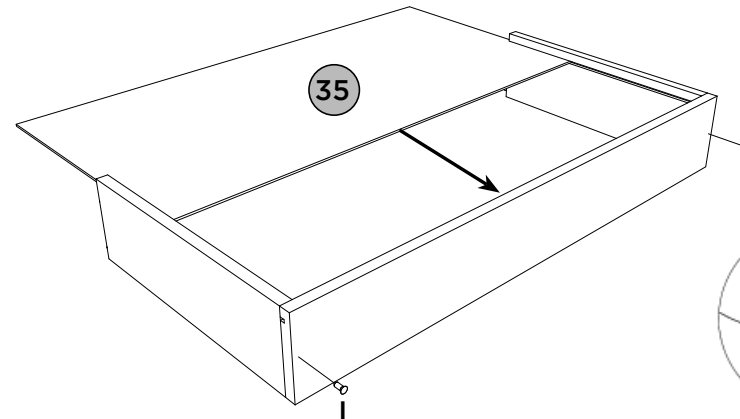

4x

3º

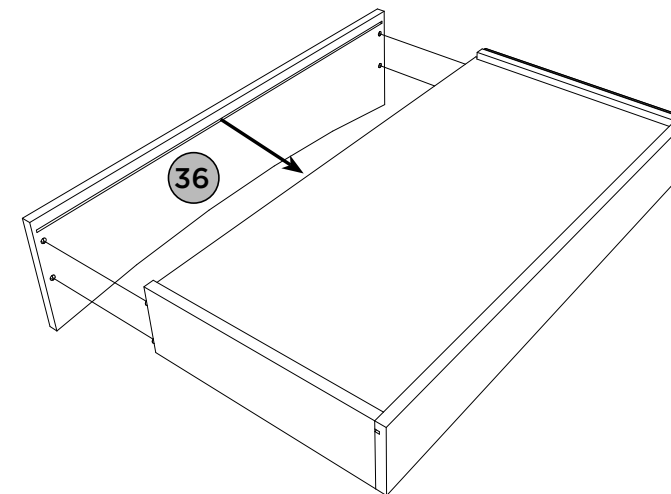





### PASSO 20

PEÇAS REQUERIDAS

34	LADO DE GAVETA	x8
----	----------------	----

ACESSÓRIOS REQUERIDOS

E		08
M		32
AC		
AH		08

FERRAMENTAS NECESSÁRIAS

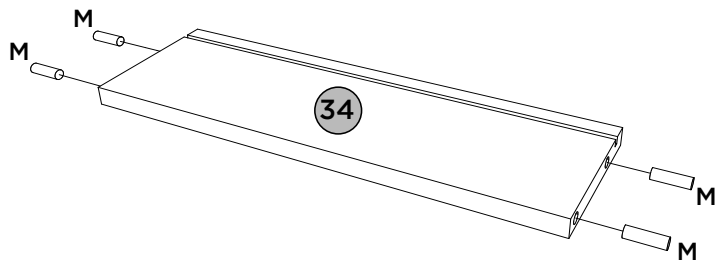
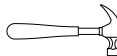

### PASSO 21

PEÇAS REQUERIDAS

33	RIPA DE TRÁS	x4
34	LADO DE GAVETA	x8

ACESSÓRIOS REQUERIDOS

AC		
----	---	--

**4x**

1º

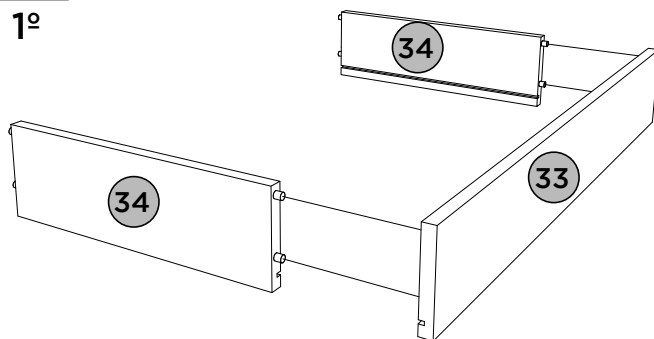

## LISTA DE PEÇAS | LISTA DE PIEZAS | LIST OF PIECES

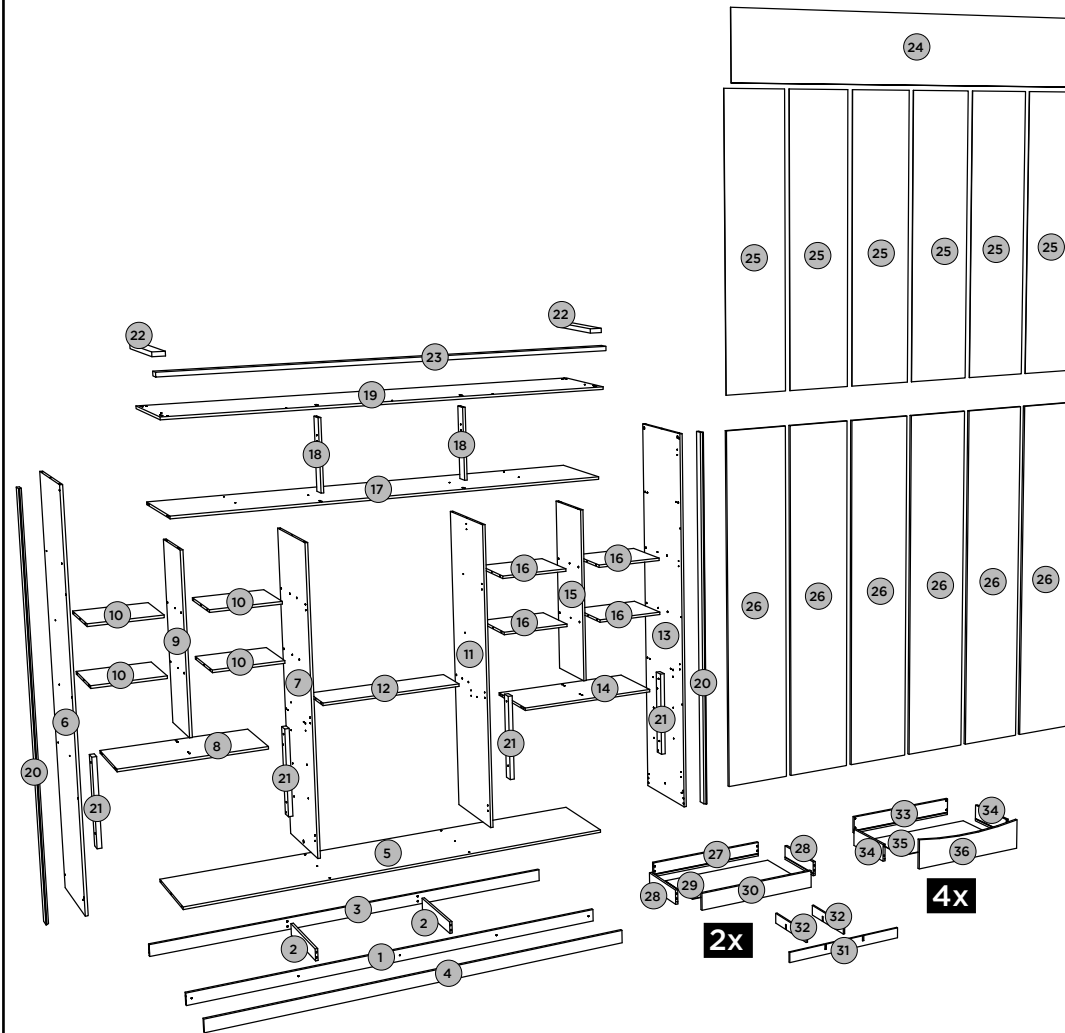



# PASSO 1

ITM/D311-

## PEÇAS REQUERIDAS

1	RODAPÉ FRONTAL	x1
2	TRAVESSA DO RODAPÉ	x2
3	RODAPÉ TRASEIRO	x1
18	RIPA DO MALEIRO	x2

## ACESSÓRIOS REQUERIDOS

D		04
M		20
Q		04

## FERRAMENTAS NECESSÁRIAS

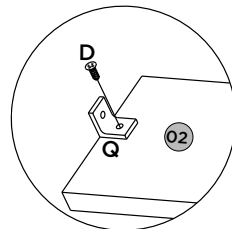
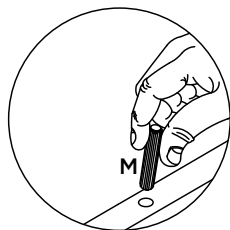
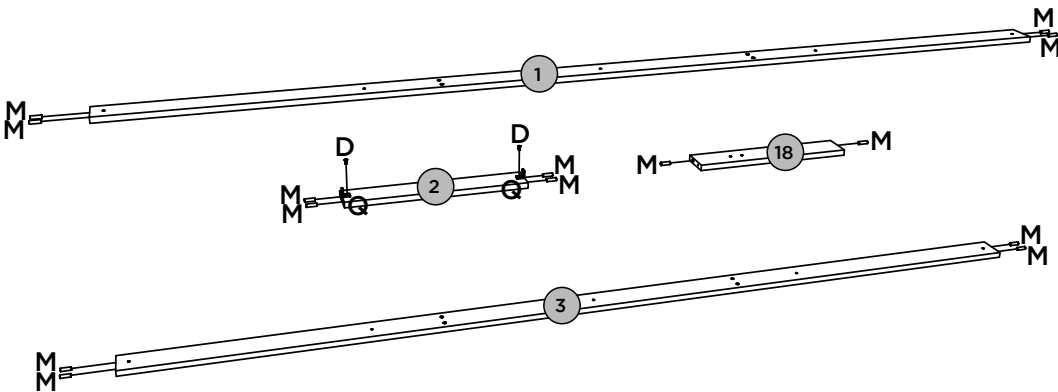
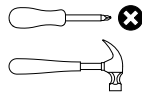





# PASSO 19

## PEÇAS REQUERIDAS

31	DIVISÓRIA MAIOR	x2
32	DIVISÓRIA MENOR	x4

## ACESSÓRIOS REQUERIDOS

E		12
J		04
R		04
W		02

## FERRAMENTAS NECESSÁRIAS

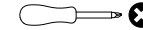

**2x**

5º

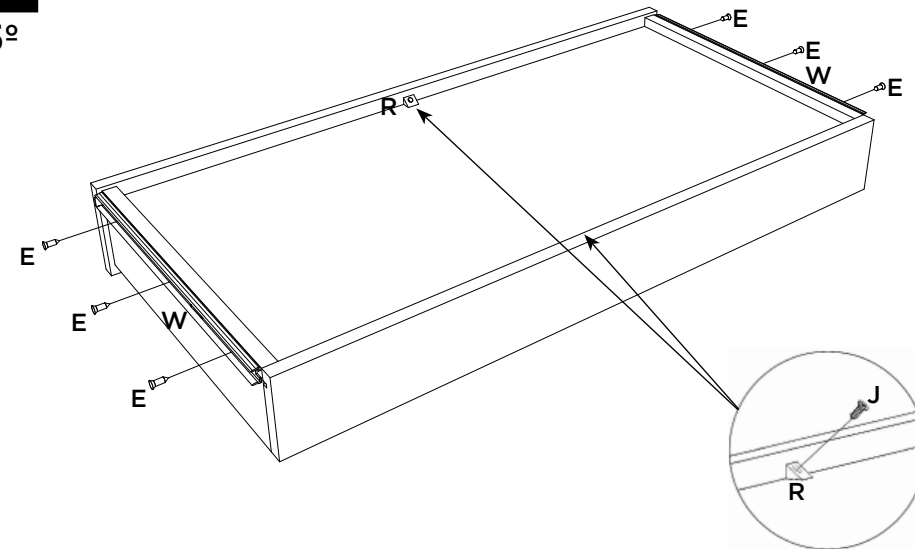

**2x**

6º

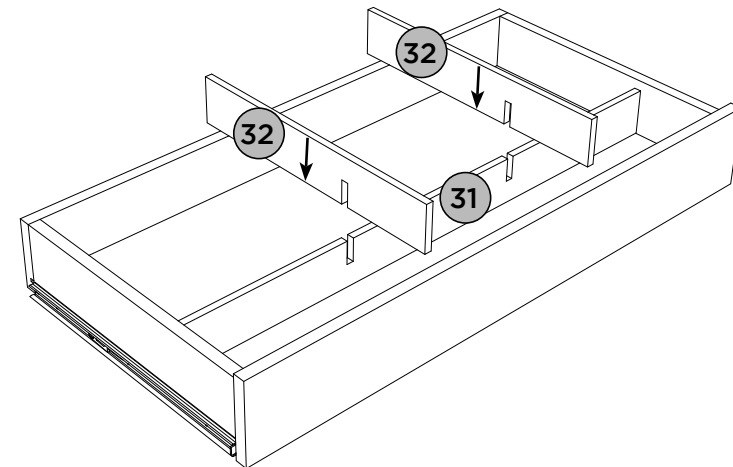

## PASSO 18

### PEÇAS REQUERIDAS

29	FUNDO DE GAVETA RECORTADO	x2
30	FRENTE DE GAVETA MENOR	x2

### ACESSÓRIOS REQUERIDOS

E		08
I		04
AC		
AH		04

### FERRAMENTAS NECESSÁRIAS

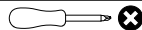
**2x**

2º

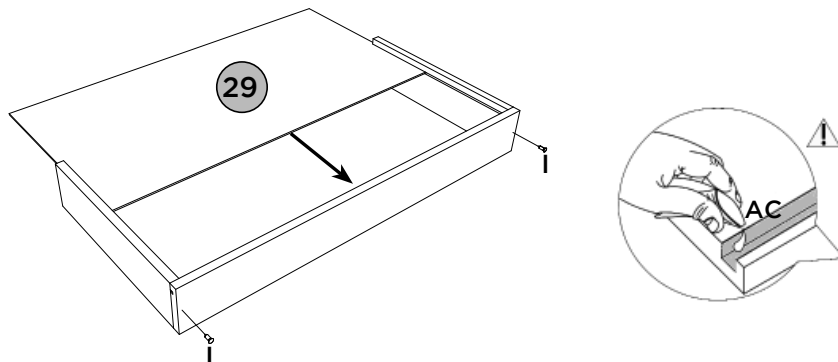
**2x**

3º

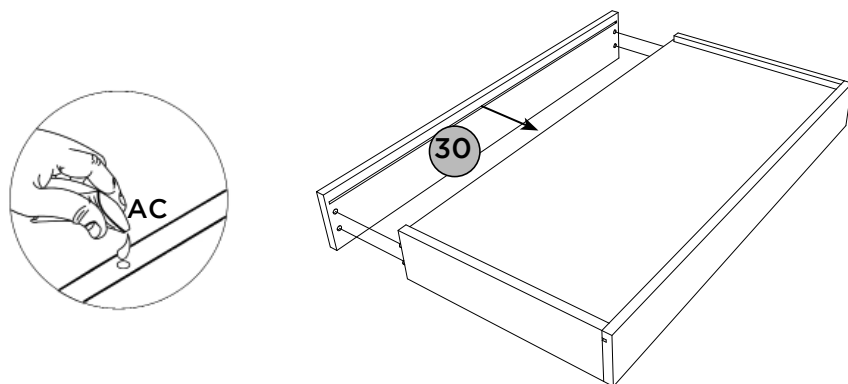
**2x**

4º

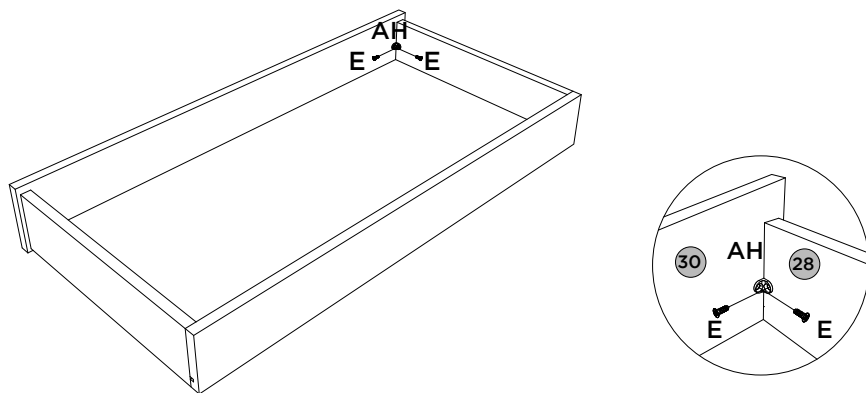

## PASSO 2

### PEÇAS REQUERIDAS

5	BASE	x1
6	LATERAL ESQUERDA	x1
7	DIVISÃO ESQUERDA	x1

### ACESSÓRIOS REQUERIDOS

D		14
E		04
K		02
M		07
N		04
P		06
U		02
Y		04

### FERRAMENTAS NECESSÁRIAS

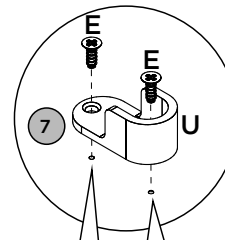
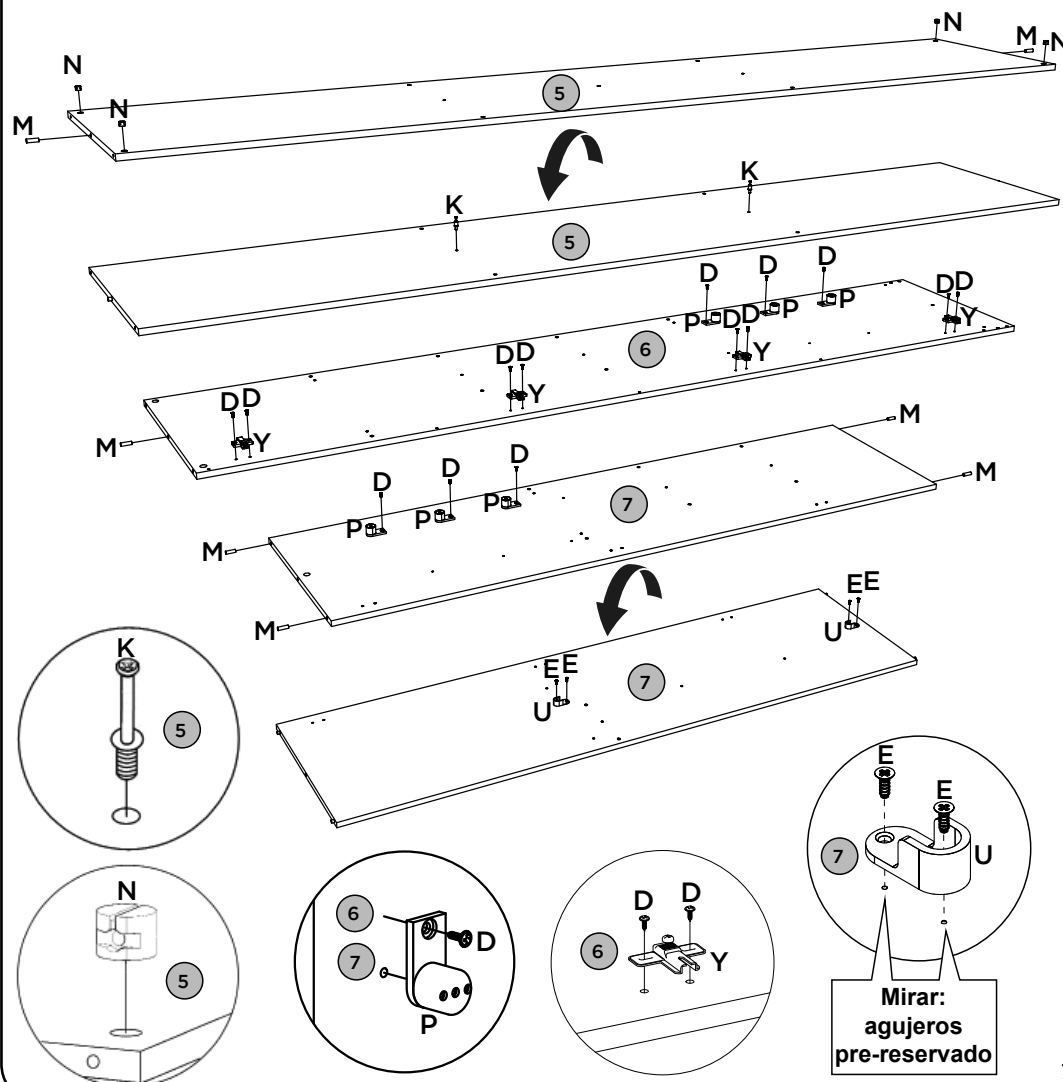
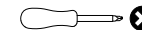

Mirar:  
agujeros  
pre-reservado

### PASSO 3

ITM/D311-

#### PEÇAS REQUERIDAS

08=14	TAMPO DAS GAVETAS	x2
09=15	DIVISÃO SUPERIOR	x2
10=16	PRATELEIRA	x8
11	DIVISÃO DIREITA	x1
12	PRATELEIRA DO CALCEIRO	x1

#### ACESSÓRIOS REQUERIDOS

D		03
E		04
M		56
P		03
U		02

#### FERRAMENTAS NECESSÁRIAS

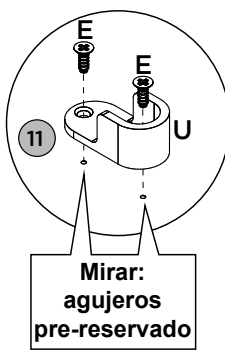
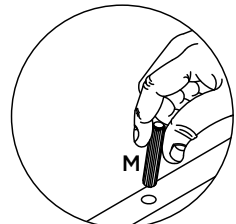
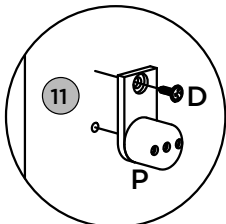
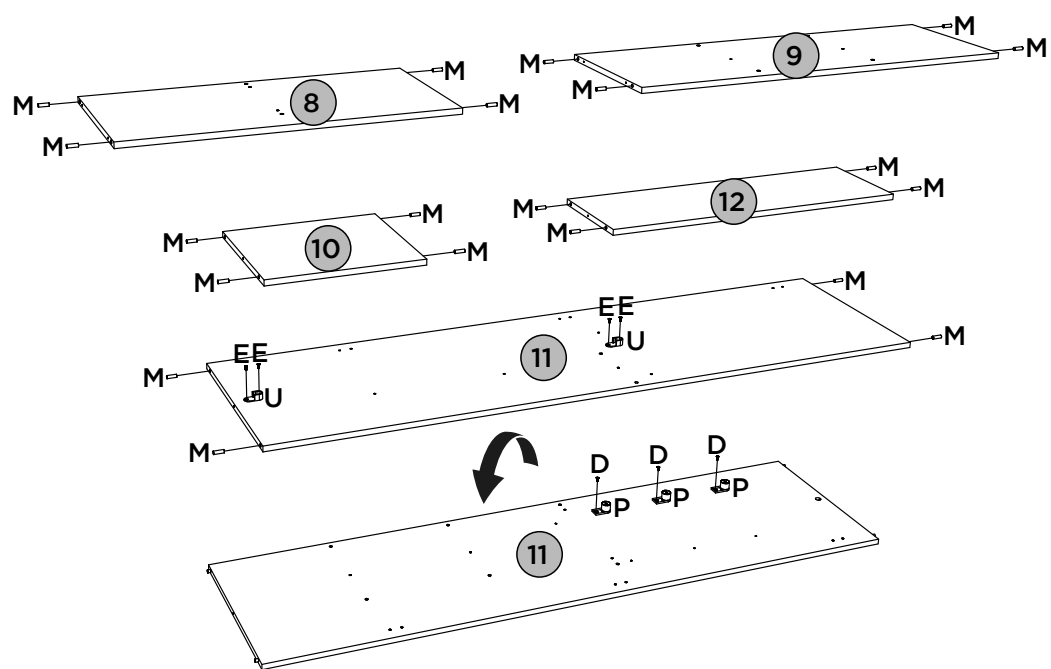
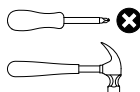

Mirar:  
agujeros  
pre-reservado

### PASSO 16

#### PEÇAS REQUERIDAS

28	LADO DE GAVETA MENOR	x4
----	----------------------	----

#### ACESSÓRIOS REQUERIDOS

M		16
AC		

#### FERRAMENTAS NECESSÁRIAS

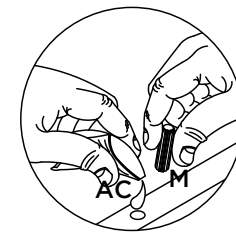
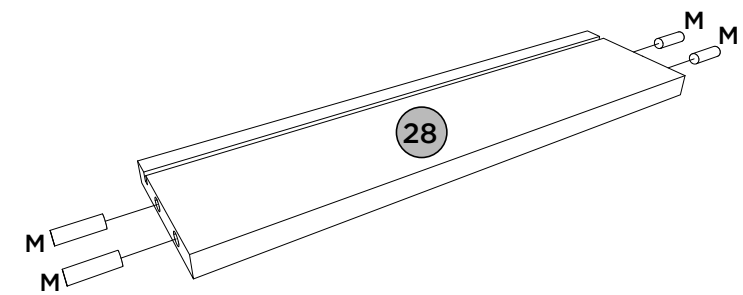
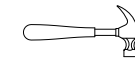

### PASSO 17

#### PEÇAS REQUERIDAS

27	RIPA DE TRÁS MENOR	x2
28	LADO DE GAVETA MENOR	x4

#### ACESSÓRIOS REQUERIDOS

AC		
----	--	--

2x  
1º

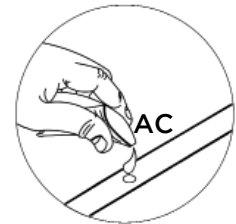
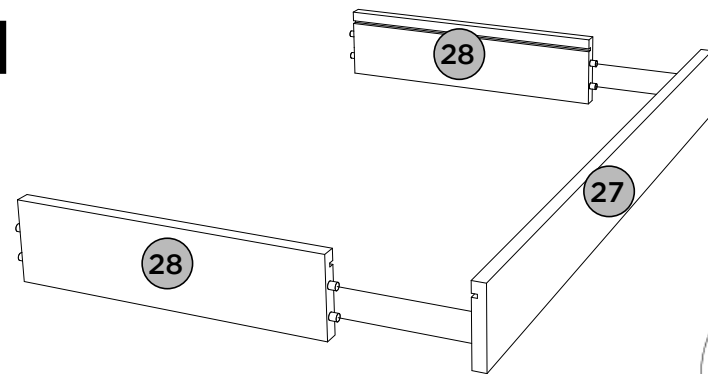

# PASSO 15

ITM/D311-

## PEÇAS REQUERIDAS

## ACESSÓRIOS REQUERIDOS

26	PORTA	x6
----	-------	----

AB		02
----	---	----

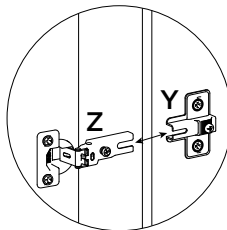
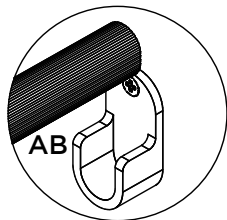

# PASSO 4





ITM/D311-

## PEÇAS REQUERIDAS

## ACESSÓRIOS REQUERIDOS

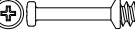
## FERRAMENTAS NECESSÁRIAS

13	LATERAL DIREITA	x1
17	CHÃO DO MALEIRO	x1
19	TAMPO SUPERIOR	x1

D		11
K		04
M		05
P		03
Y		04

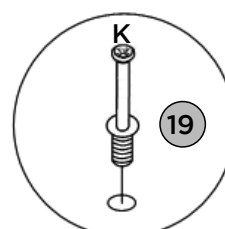
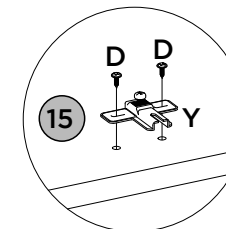
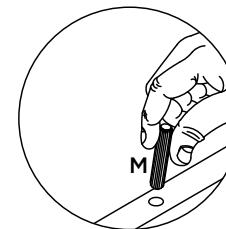
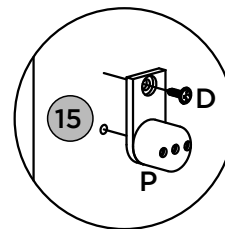
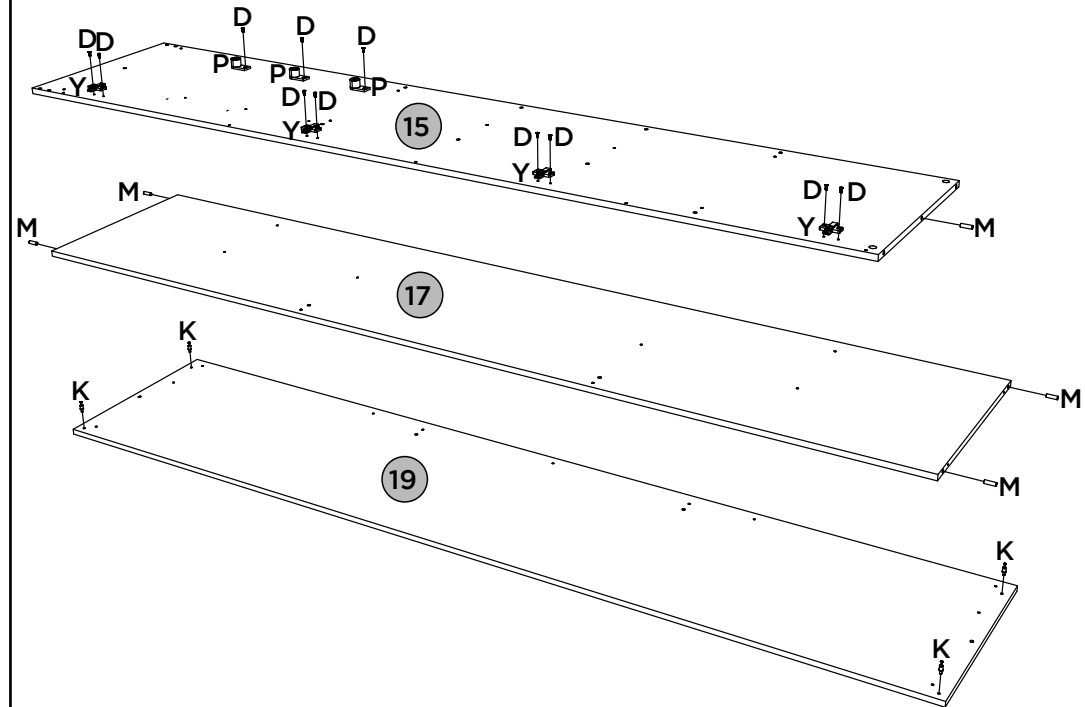
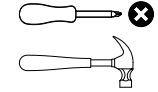



# PASSO 5

ITM/D311-

## PEÇAS REQUERIDAS

1	RODAPÉ FRONTAL	x1
2	TRAVESSA DO RODAPÉ	x2
3	RODAPÉ TRASEIRO	x1
4	MOLDURA FRONTAL INFERIOR	x1

## ACESSÓRIOS REQUERIDOS

D		04
G		05

## FERRAMENTAS NECESSÁRIAS

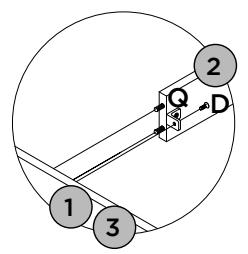
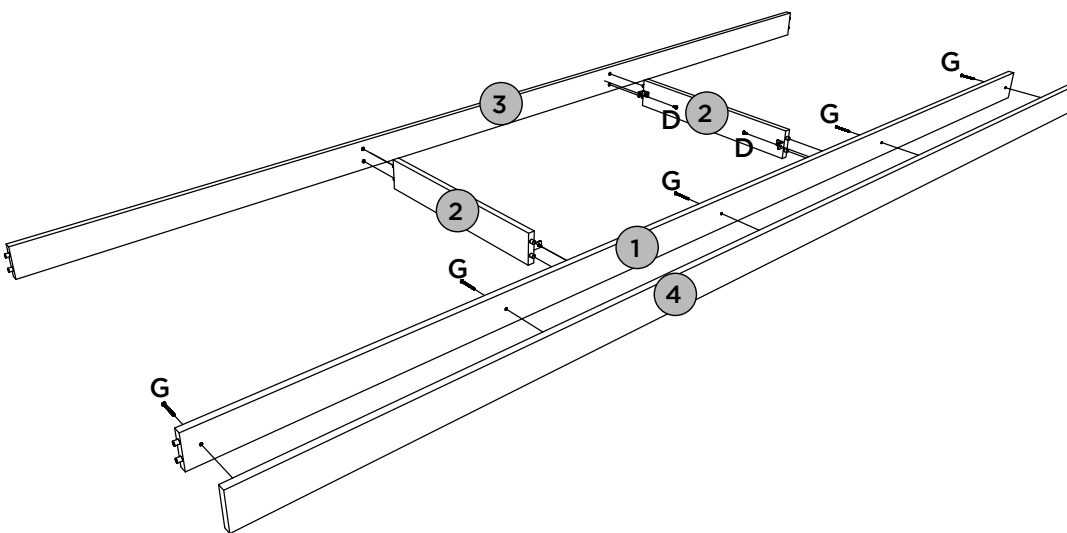
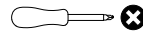





# PASSO 14

ITM/D311-

## PEÇAS REQUERIDAS

26	PORTA	x6
----	-------	----

## ACESSÓRIOS REQUERIDOS

D		48
H		18
V		06
Z		24

## FERRAMENTAS NECESSÁRIAS

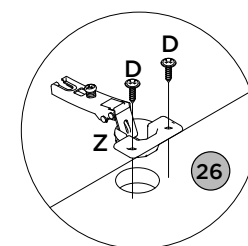
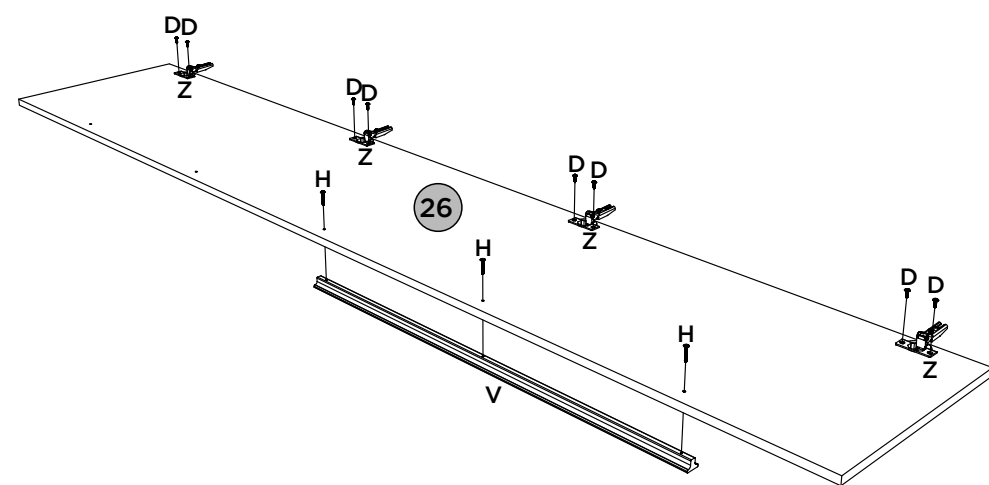
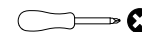

# PASSO 13



ITM/D311-

## PEÇAS REQUERIDAS

## ACESSÓRIOS REQUERIDOS

## FERRAMENTAS NECESSÁRIAS

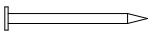
24	FUNDO SUPERIOR	x1
25	FUNDO	x6

S		204
T		55
AA		03

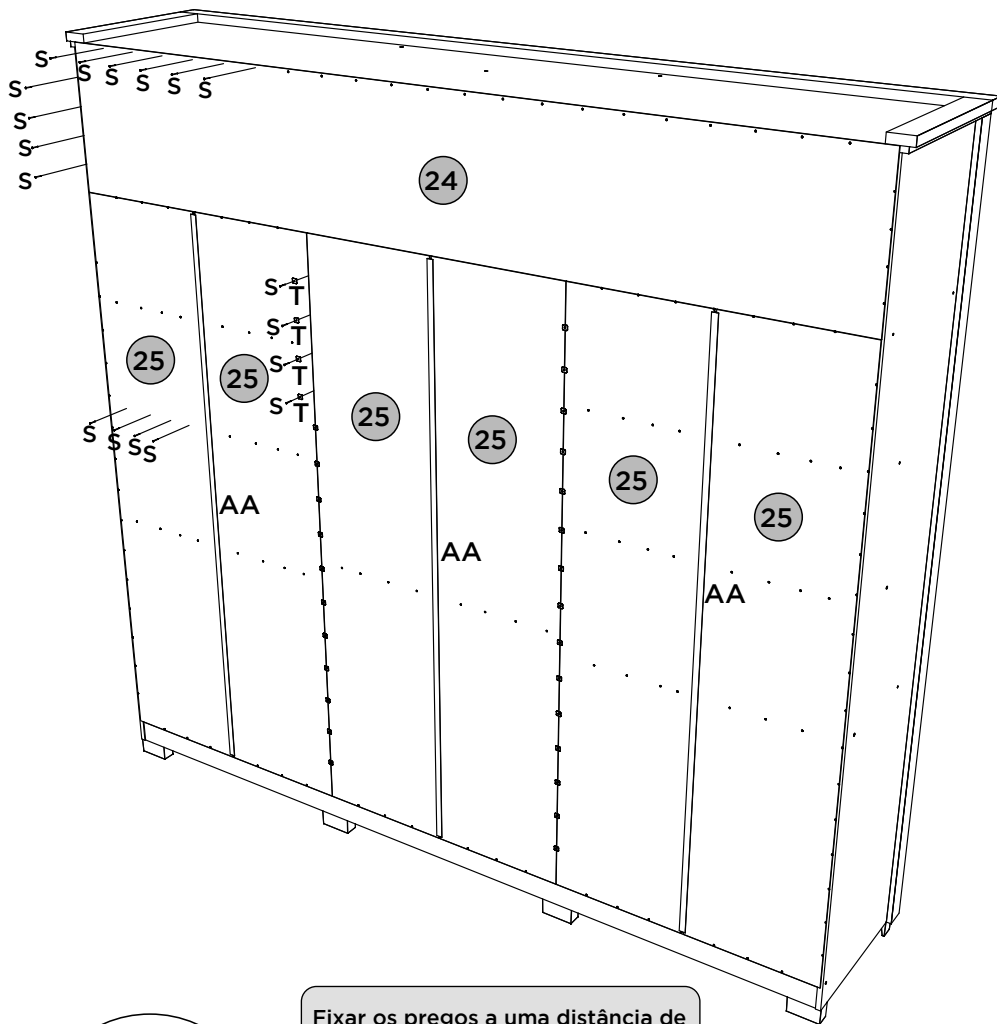
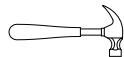

Fixar os pregos a uma distância de 100mm de um para outro.

Fijar las uñas a un distancia de 100mm uno a otro.

Fix the nails at a distance of 100mm from one to the other

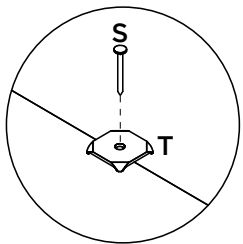

# PASSO 6



ITM/D311-

## PEÇAS REQUERIDAS

## ACESSÓRIOS REQUERIDOS

## FERRAMENTAS NECESSÁRIAS

5	BASE	x1
---	------	----

B		08
D		24
X		08

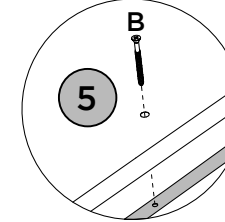
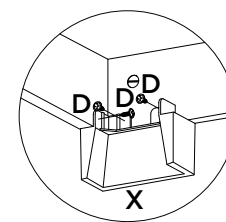
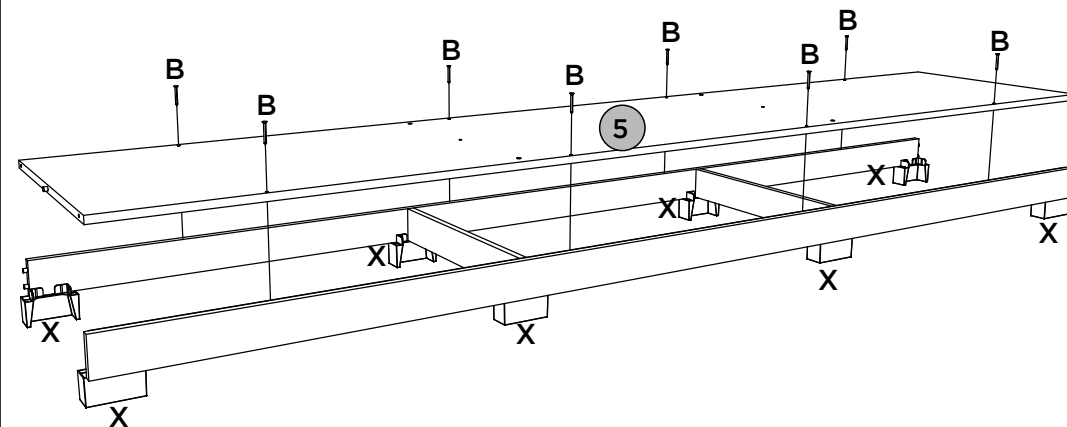
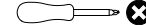

# PASSO 7

ITM/D311-

## PEÇAS REQUERIDAS

6	LATERAL ESQUERDA	x1
7	DIVISÃO ESQUERDA	x1
8	TAMPO DAS GAVETAS	x1
9	DIVISÃO SUPERIOR	x1
10	PRATELEIRA	x4

## ACESSÓRIOS REQUERIDOS

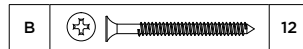

## FERRAMENTAS NECESSÁRIAS

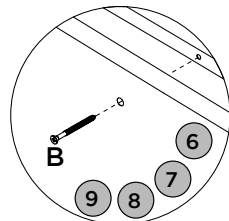
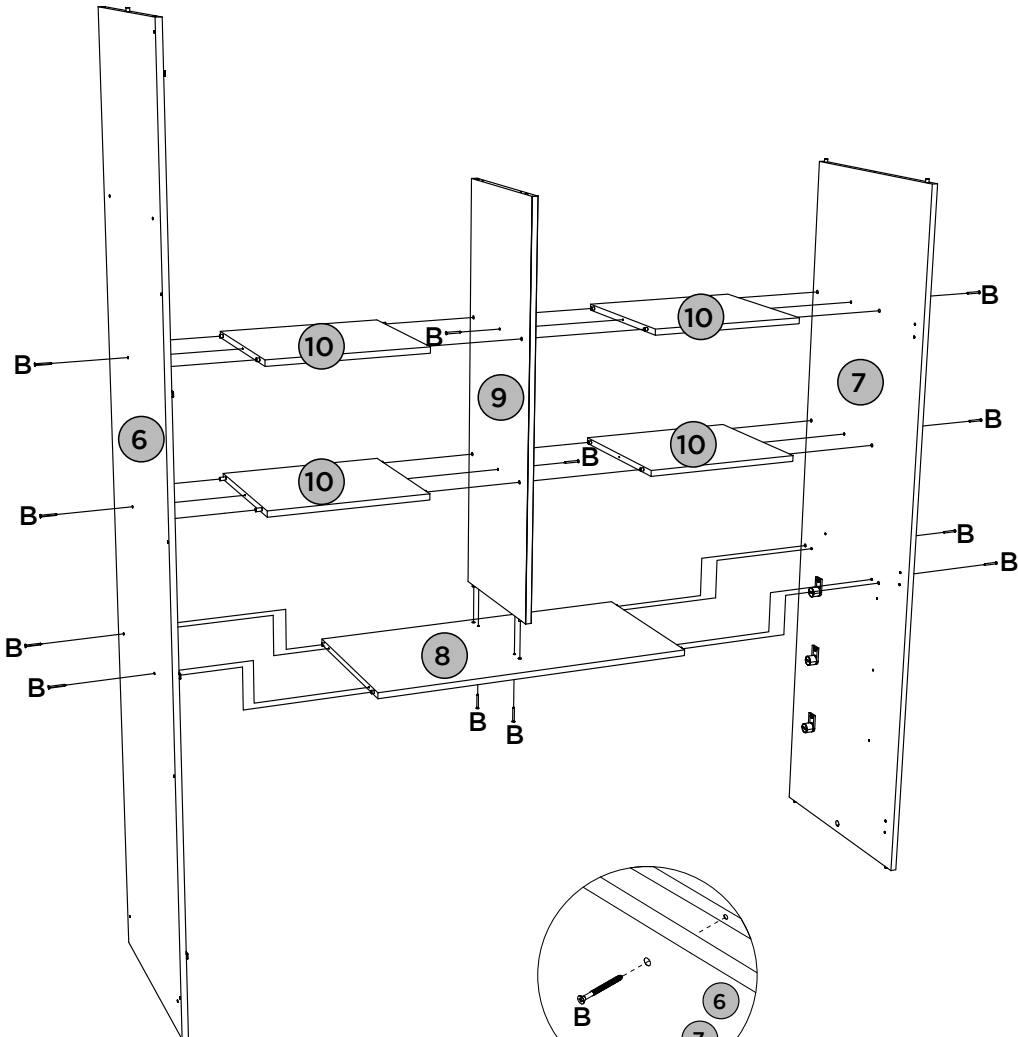
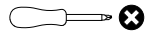

# PASSO 12

ITM/D311-

## ACESSÓRIOS REQUERIDOS

C		16
E		24
O		16
W		06
Y		16

## FERRAMENTAS NECESSÁRIAS

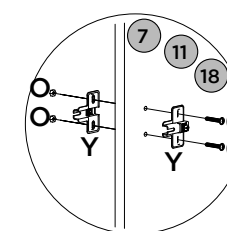
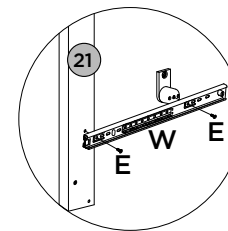
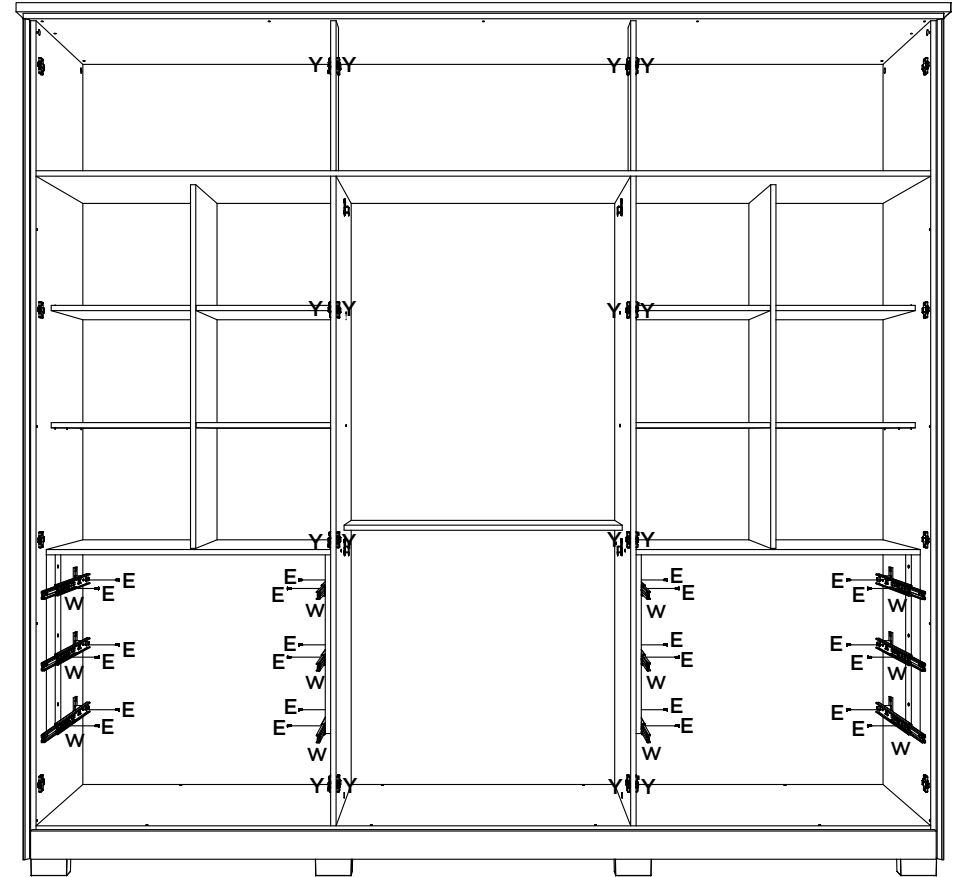
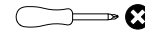

# PASSO 11

ITM/D311-

## PEÇAS REQUERIDAS

21	RIPA LATERAL	x4
22	MOLDURA LATERAL SUPERIOR	x2
23	MOLDURA FRONTAL SUPERIOR	x1

## ACESSÓRIOS REQUERIDOS

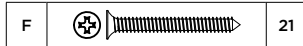

## FERRAMENTAS NECESSÁRIAS

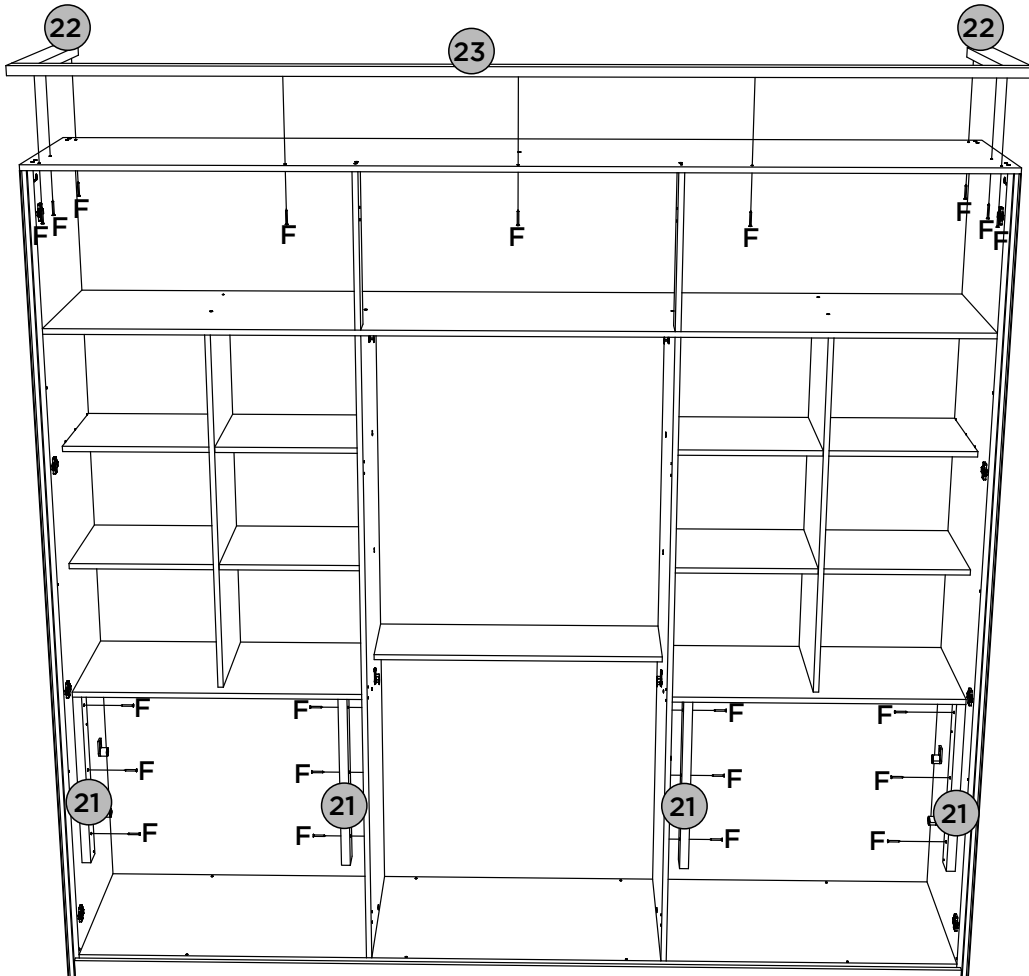
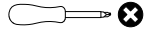

# PASSO 8

ITM/D311-

## PEÇAS REQUERIDAS

11	DIVISÃO DIREITA	x1
12	PRATELEIRA DO CALCEIRO	x1

## ACESSÓRIOS REQUERIDOS

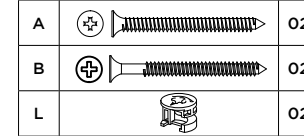

## FERRAMENTAS NECESSÁRIAS

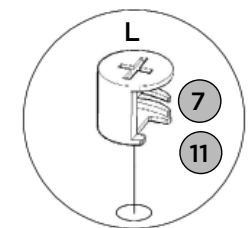
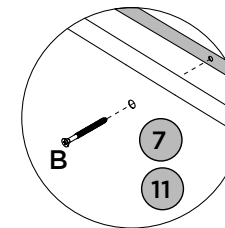
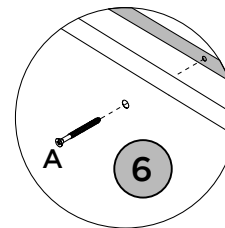
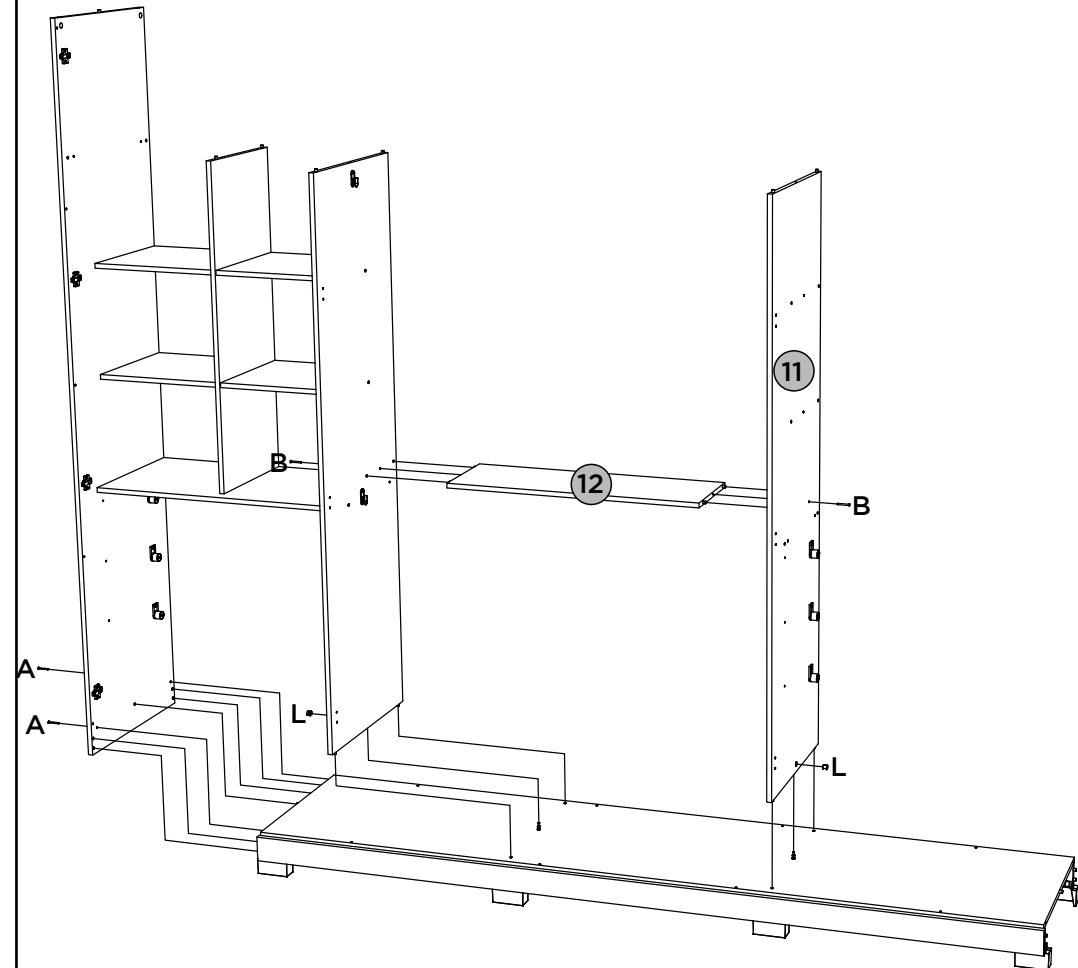
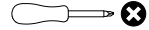



# PASSO 9

ITM/D311-

## PEÇAS REQUERIDAS

13	LATERAL DIREITA	x1
14	TAMPO DAS GAVETAS	x1
15	DIVISÃO SUPERIOR	x1
16	PRATELEIRA	x4
17	CHÃO DO MALEIRO	x1
18	RIPA DO MALEIRO	x2

## ACESSÓRIOS REQUERIDOS

A		02
B		24

## FERRAMENTAS NECESSÁRIAS

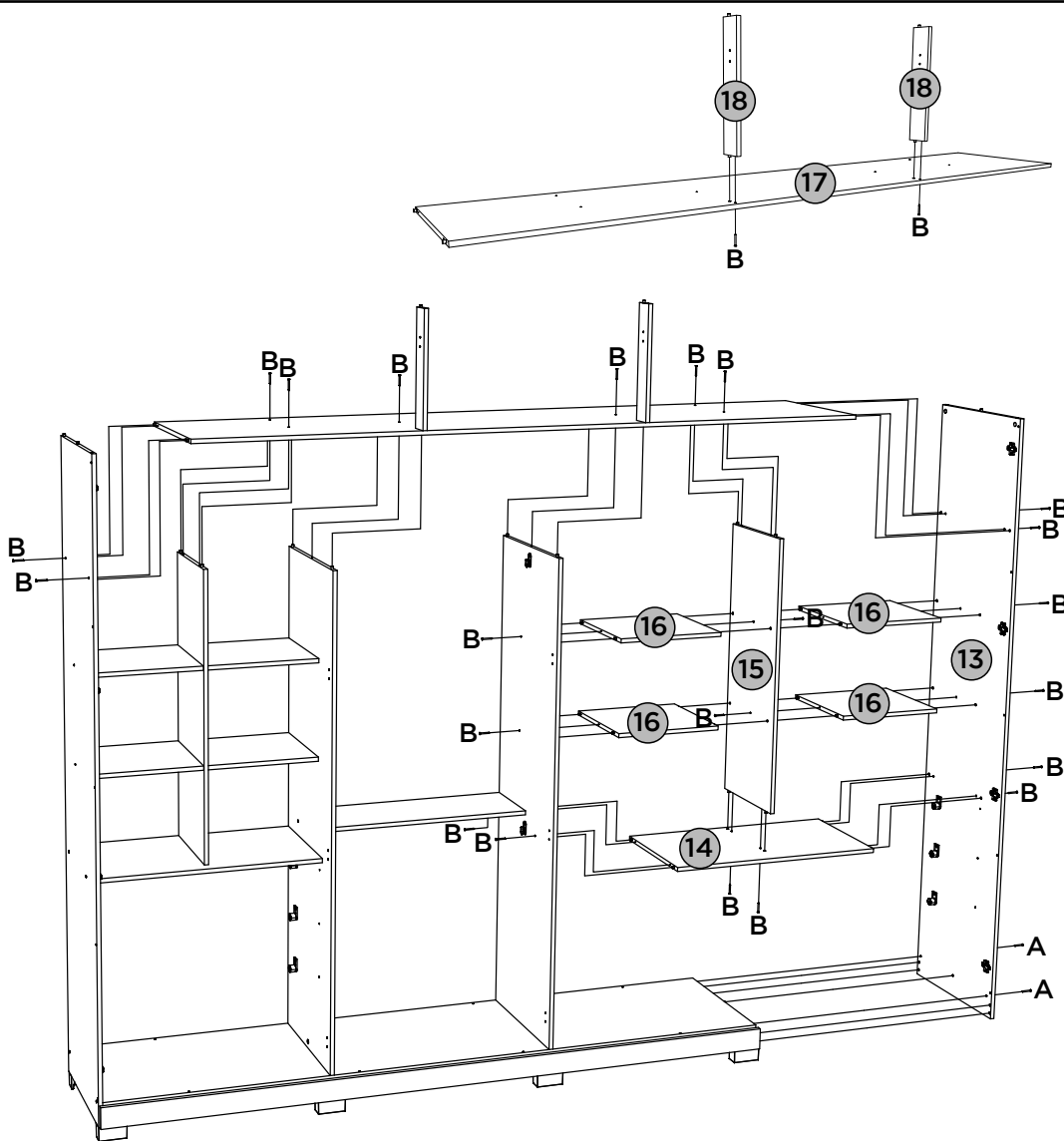
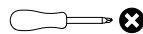



# PASSO 10

ITM/D311-

## PEÇAS REQUERIDAS

19	TAMPO SUPERIOR	x1
20	MOLDURA LATERAL	x2

## ACESSÓRIOS REQUERIDOS

B		02
G		10
L		04

## FERRAMENTAS NECESSÁRIAS

