

# ASSEMBLY INSTRUCTIONS MANUAL DE MONTAGEM / INSTRUCCIONES DE ARMADO

Iracema dressing table  
Penteadeira Iracema  
Tocador Iracema

Reference 200062 | Revise 01  
Referência 200062 | Revisão 01  
Referencia 200062 | Revisión 01

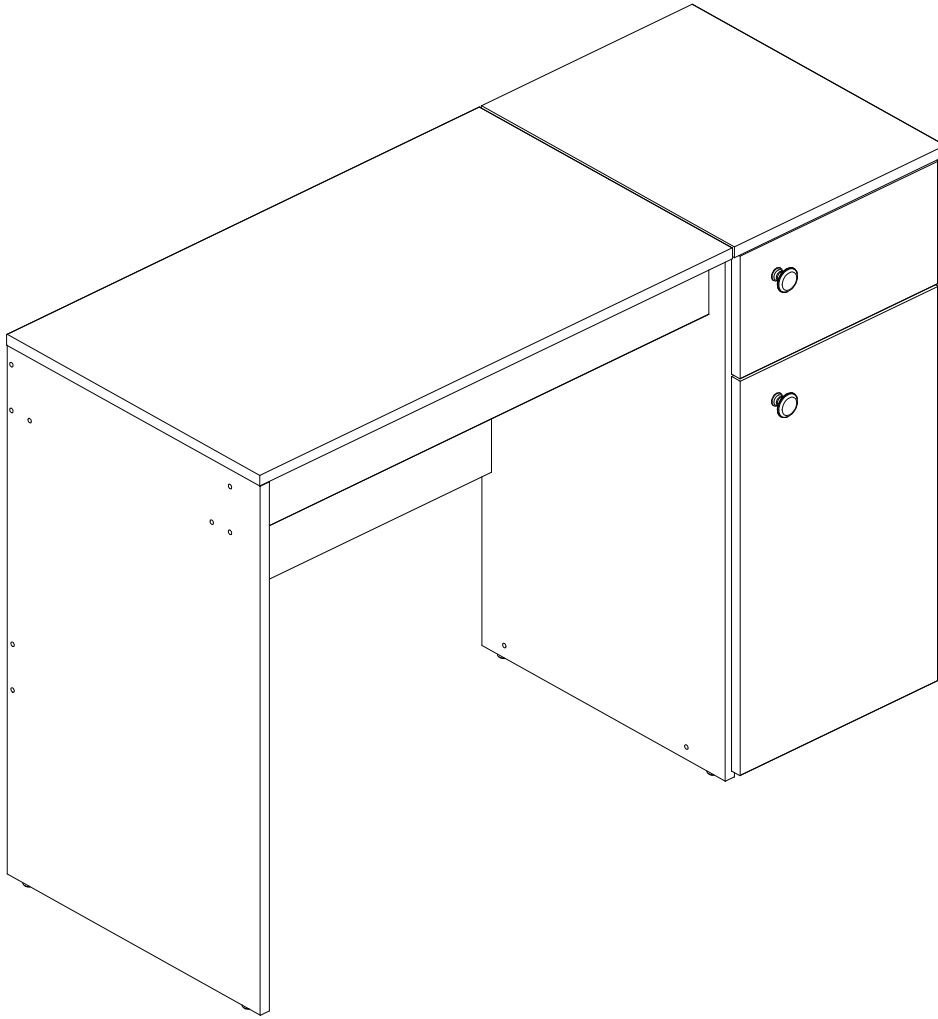

## YOU WILL NEED / VOCÊ VAI PRECISAR DE / USTED NECESITARÁ

### Tools not supplied / Ferramentas não fornecidas / Herramientas no incluidas

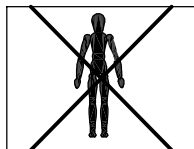

1 Person  
1 Pessoa  
1 Persona

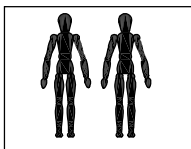

2 People  
2 Pessoas  
2 Personas

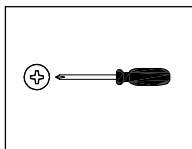

Screwdriver Phillips  
Chave Phillips  
Destornillador cruz

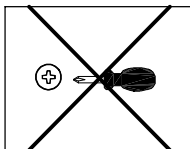

Small screwdriver Phillips  
Chave Phillips Menor  
Destornillador cruz menor

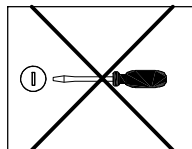

Screwdriver slotted  
Chave fenda  
Destornillador plano

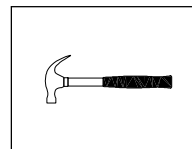

Hammer  
Martelo  
Martillo

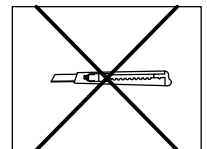

Stylet  
Estilete  
Estilete

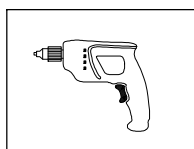

Drill machine  
Furadeira  
Taladro

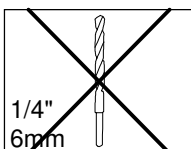

Drill bit  
Broca  
Taladro

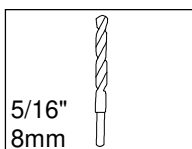

Drill bit  
Broca  
Taladro

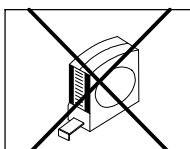

Measuring tape  
Trena  
Cinta de medición

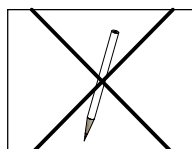

Pencil  
Lápis  
Lápis

**NOTES:** The separation of the accessories before you start the assembly will facilitate the same. In case of doubt on the size of the screws and bolts, use the ruler to bottom of page 3.

**NOTAS:** A separação dos acessórios antes de iniciar a montagem facilitará a mesma. Em caso de dúvida no tamanho dos parafusos e cavilhas, utilize a régua ao final da página 3.

**NOTAS:** La separación de los accesorios antes de comenzar el armado facilitará el mismo. En caso de duda sobre el tamaño de los tornillos y taquetes, utilice la regla al pie de página 3.

MAXIMUM RECOMMENDED WEIGHT  
BEING THIS EVENLY DISTRIBUTED

PESO MÁXIMO RECOMENDADO SENDO  
ESTE DISTRIBUÍDO UNIFORMEMENTE

PESO MÁXIMO RECOMENDADO SIENDO  
ESTE UNIFORMEMENTE DISTRIBUIDO

	LB	KG
<b>A</b>	22	10
<b>B</b>	11	5
<b>C</b>	6,6	3

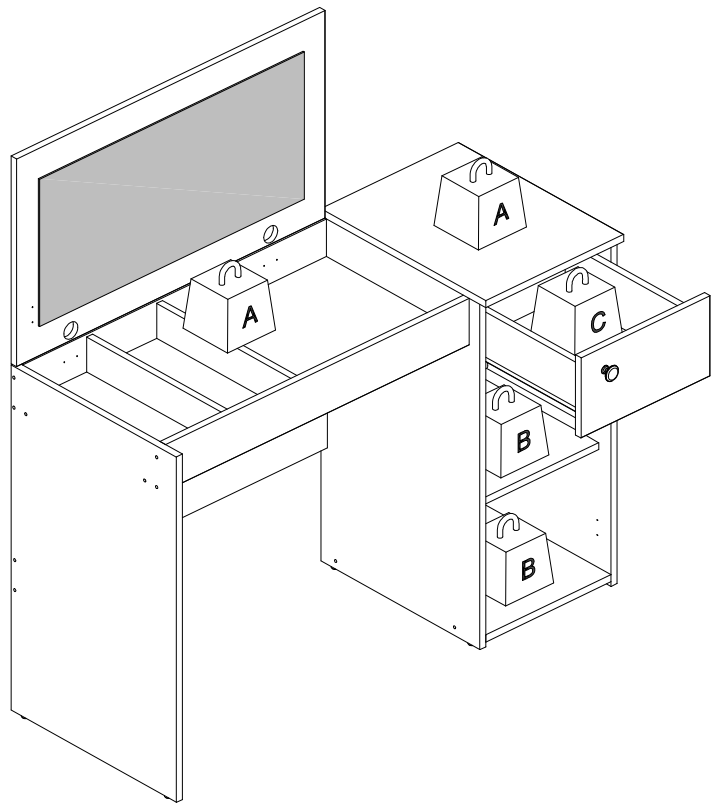





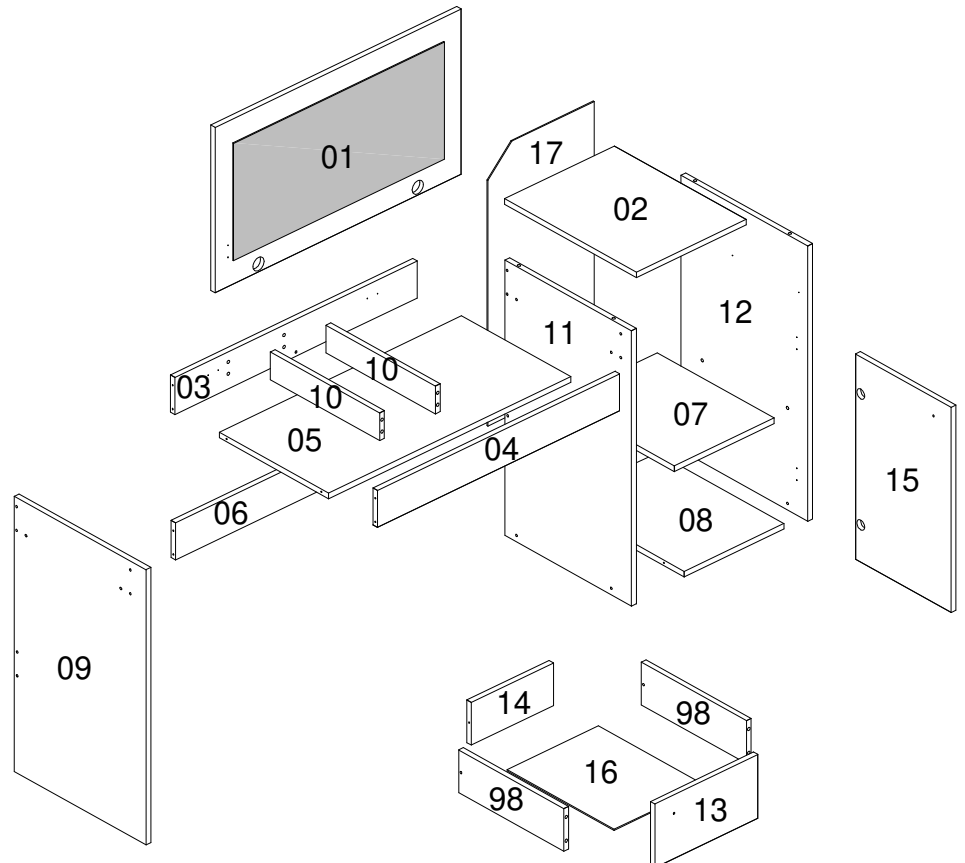







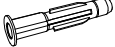

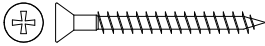

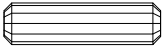



Nº	Measures Inches	Medidas cm	Qty./Qtd.
01	30 3/8 x 17 1/2 x 5/8	77,2 x 44,5 x 1,5	1
02	13 5/8 x 17 1/2 x 5/8	34,5 x 44,5 x 1,5	1
03	29 7/8 x 3 7/8 x 5/8	76 x 10 x 1,5	1
04	29 7/8 x 3 7/8 x 5/8	76 x 10 x 1,5	1
05	29 7/8 x 14 1/2 x 5/8	76 x 36,9 x 1,5	1
06	29 7/8 x 3 7/8 x 5/8	76 x 10 x 1,5	1
07	12 3/8 x 15 1/2 x 5/8	31,3 x 39,5 x 1,5	1
08	12 3/8 x 16 7/8 x 5/8	31,3 x 42,8 x 1,5	1
09	29 1/8 x 17 1/2 x 5/8	74 x 44,5 x 1,5	1
10	3 x 14 1/2 x 5/8	7,5 x 36,9 x 1,5	2
11	29 1/8 x 16 7/8 x 5/8	74 x 42,8 x 1,5	1
12	29 1/8 x 16 7/8 x 5/8	74 x 42,8 x 1,5	1
13	12 3/4 x 6 3/4 x 5/8	32,3 x 17,2 x 1,5	1
14	10 1/8 x 4 1/2 x 5/8	25,8 x 11,5 x 1,5	1
15	12 3/4 x 21 3/4 x 5/8	32,3 x 55,2 x 1,5	1
16	11 1/4 x 14 1/4 x 1/8	28,6 x 36,1 x 0,3	1
17	28 7/8 x 13 1/8 x 1/8	73,5 x 33,3 x 0,3	1
98	14 x 4 1/2 x 5/8	35,5 x 11,5 x 1,5	2

**PARTS IDENTIFICATION**  
**IDENTIFICAÇÃO DAS PEÇAS / IDENTIFICACIÓN DE LAS PIEZAS**

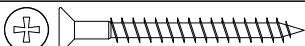
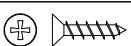
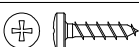

# IDENTIFICATION OF ACCESSORIES IDENTIFICAÇÃO DOS ACESSÓRIOS/ IDENTIFICACIÓN DE ACCESORIOS

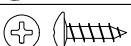
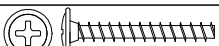
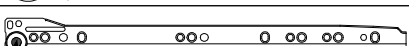
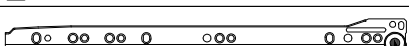
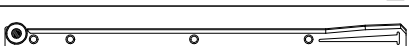
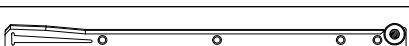
A		Flanged head screw / Parafuso flangeado / Tornillo de cabeza flangeada	5,0x60 mm	1
A1		Glue / Cola / Pegamento	13 g	1
A2		Small plastic foot / Sapata redonda / Pie plástico	14 mm	6
A4		Metalic bracket / Cantoneira de metal / Suporte de metal	22x22 mm	6
B3		Bushing / Bucha expansiva / Tapón	8x50 mm	1
B7		Metalic bracket / Suporte de metal / Suporte de metal	-	1
D		Flat head screw / Parafuso chato / Tornillo de cabeza plana	4,0x40 mm	1
D5		Hinge shim / Calço dobradiça / Bisagra de calce	-	2
E		Wooden dowel / Cavilha / Taquete	8x30 mm	16
E3		Shelf bracket / Suporte de prateleira / Suporte de repisa	8x7 mm	4
E4		Mirror support / Suporte espelho / Suporte espejo	-	4
F6		Metal hinge curve / Dobradiça curva / Esquina de bisagra metálica	26 mm	2
H18		Handle / Puxador Grace / Tirador	-	2
J6		Metal hinge straight / Dobradiça reta / Bisagra recta	35 mm	2
J7		Hinge shim / Calço dobradiça médio / Bisagra de calce	-	2
M		Bore patch adhesive / Tapa furo adesivo / Tapones adhesivo	-	12
N		Nail / Prego / Clavo	10x10	33
O		Flat head screw / Parafuso chato / Tornillo de cabeza plana	4,5x45 mm	22
P5		Flat head screw / Parafuso chato especial / Tornillo de cabeza plana	3,5x14 mm	8
S		Pan head screw / Parafuso panela / Tornillo de pan	3,5x14 mm	34
S7A		Gas piston / Pistão a gás / Pistón de gas	-	1
S7B		Side support piston / Suporte pistão lateral / Soporte pistón lateral	-	1
S7C		Door support piston / Suporte pistão porta / Soporte pistón puerta	-	1
S7D		Pan head screw / Parafuso panela / Tornillo de pan	3,5x12 mm	5
T		Flanged head screw / Parafuso flangeado / Tornillo de cabeza flangeada	3,5x25 mm	2
VA		Metallic slide the left field / Corrediça lateral esquerda / Corredera lateral izquierda	350 mm	1
VB		Metallic slide the right field / Corrediça lateral direita / Corredera lateral derecha	350 mm	1
VC		Drawer slide left / Corrediça gaveta esquerda / Corredera izquierda cajón	350 mm	1
VD		Drawer slide right / Corrediça gaveta direita / Corredera derecha cajón	350 mm	1



PRE-ASSEMBLE  
PRÉ-MONTAGEM / PRE ARMADO

01

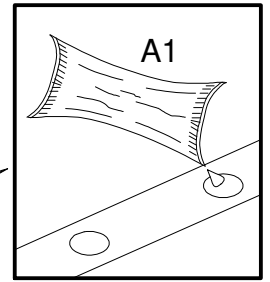
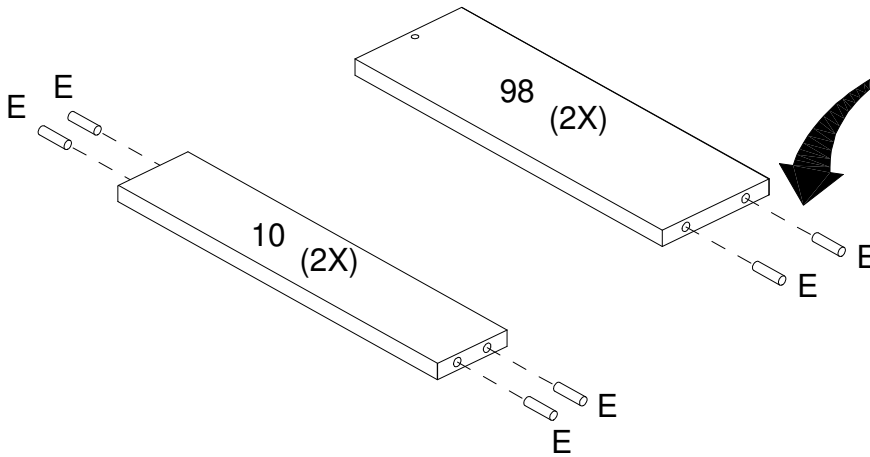
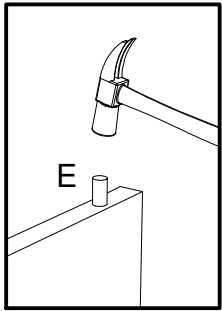

02

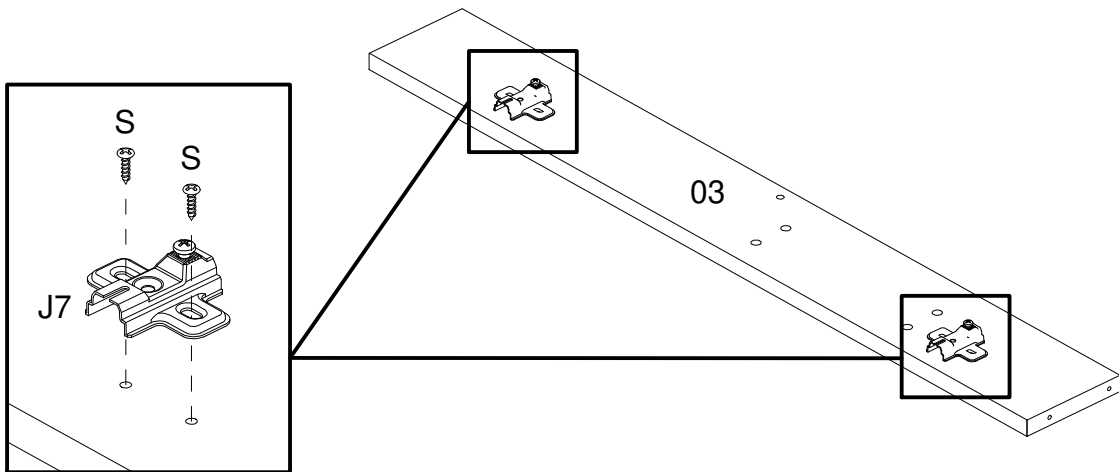

03

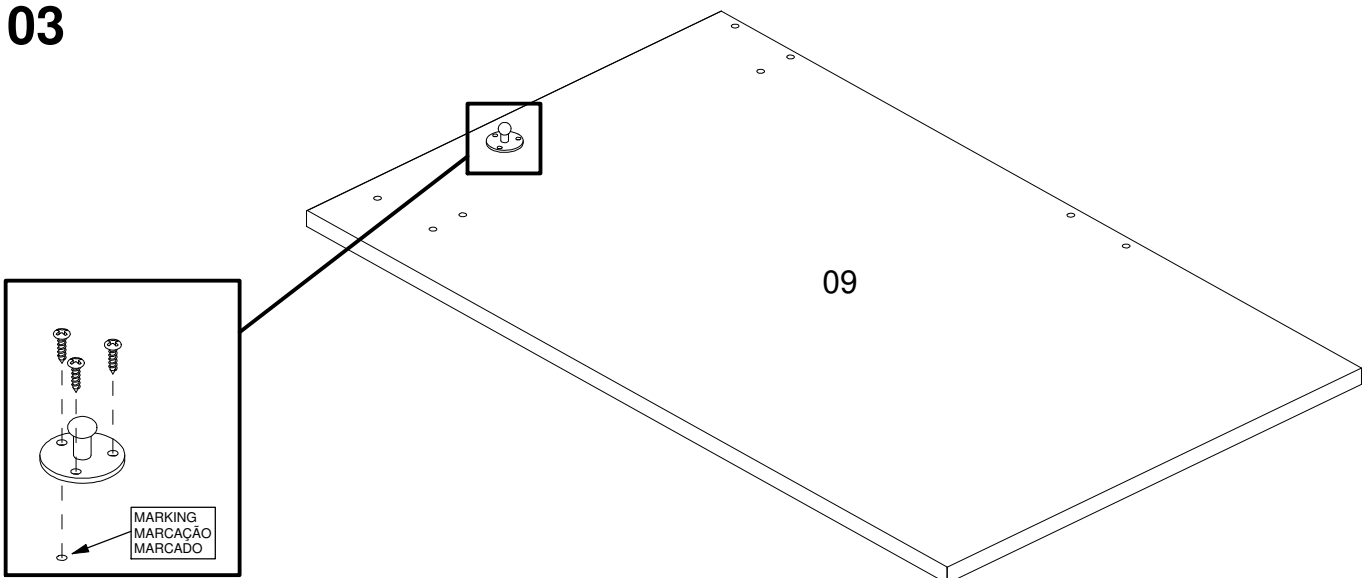

# 04

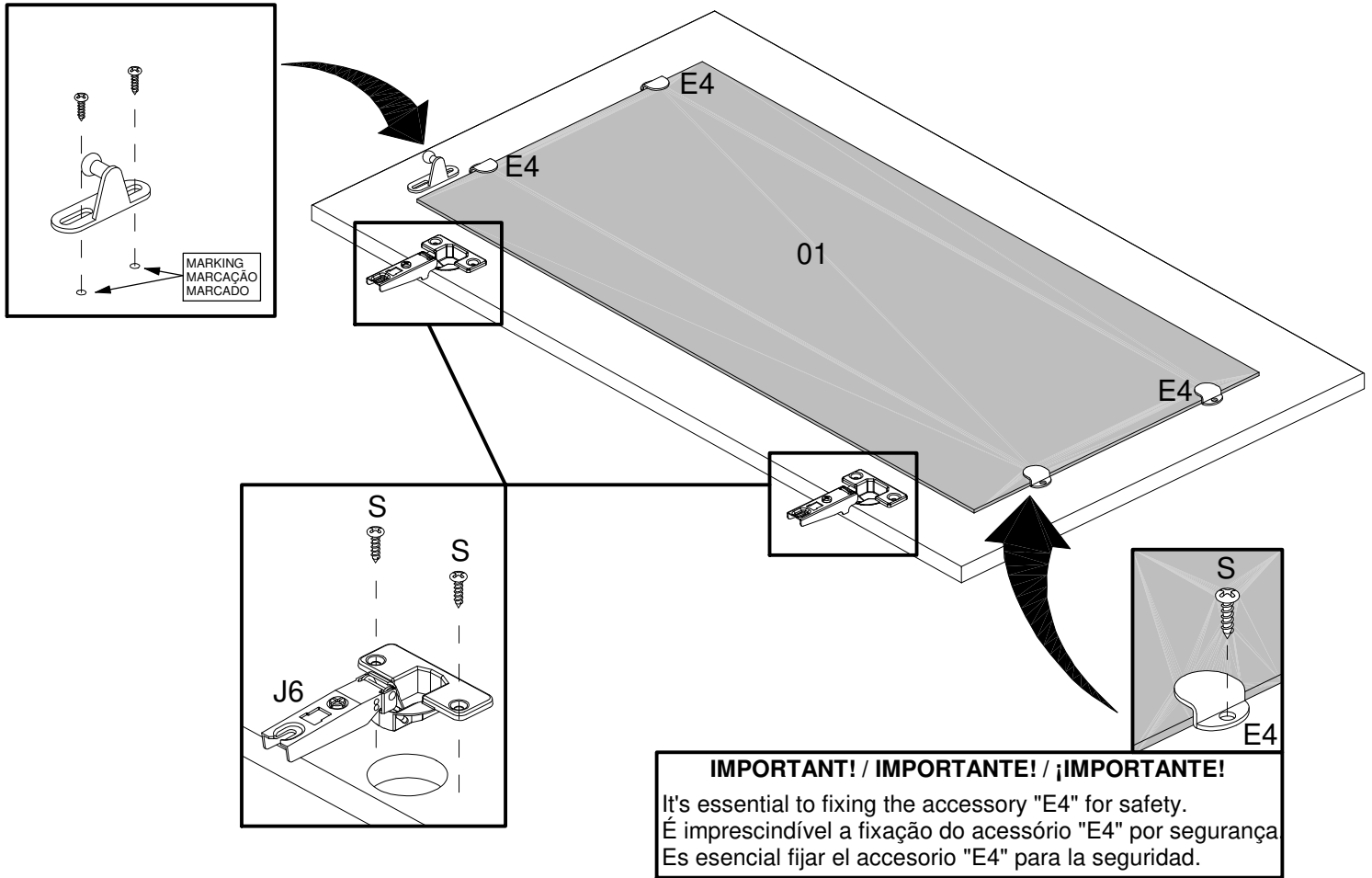

# 05

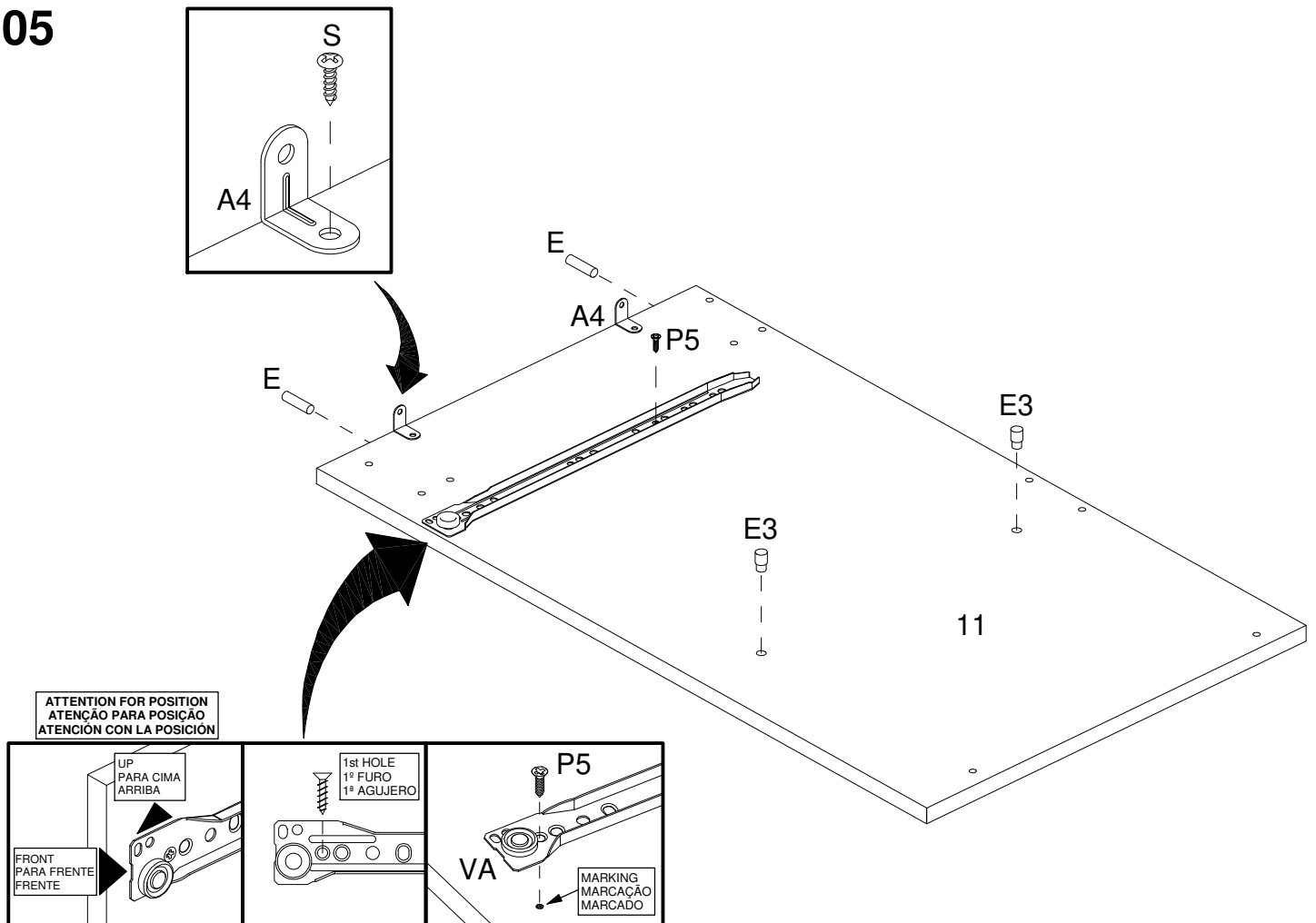

06

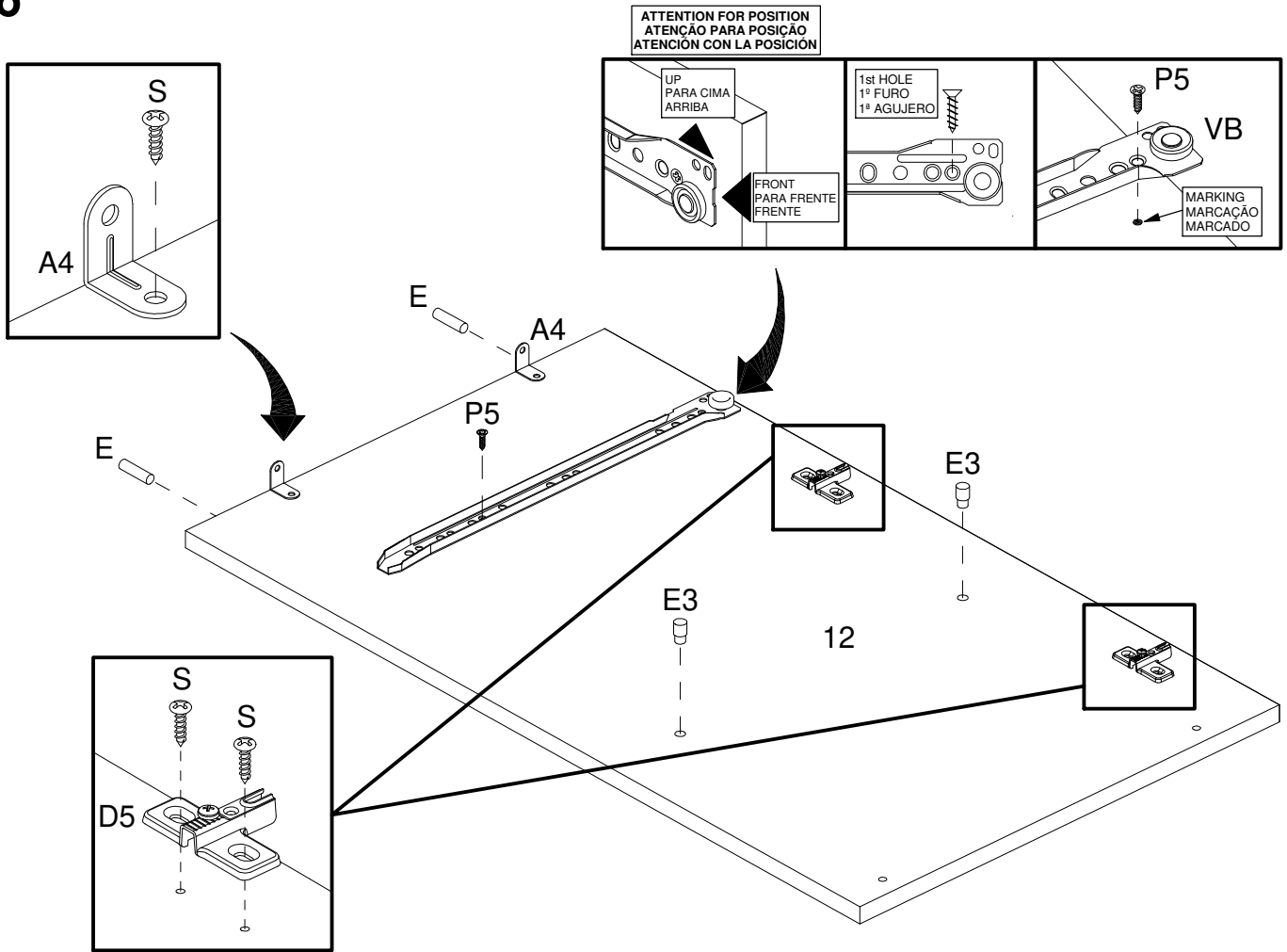

07

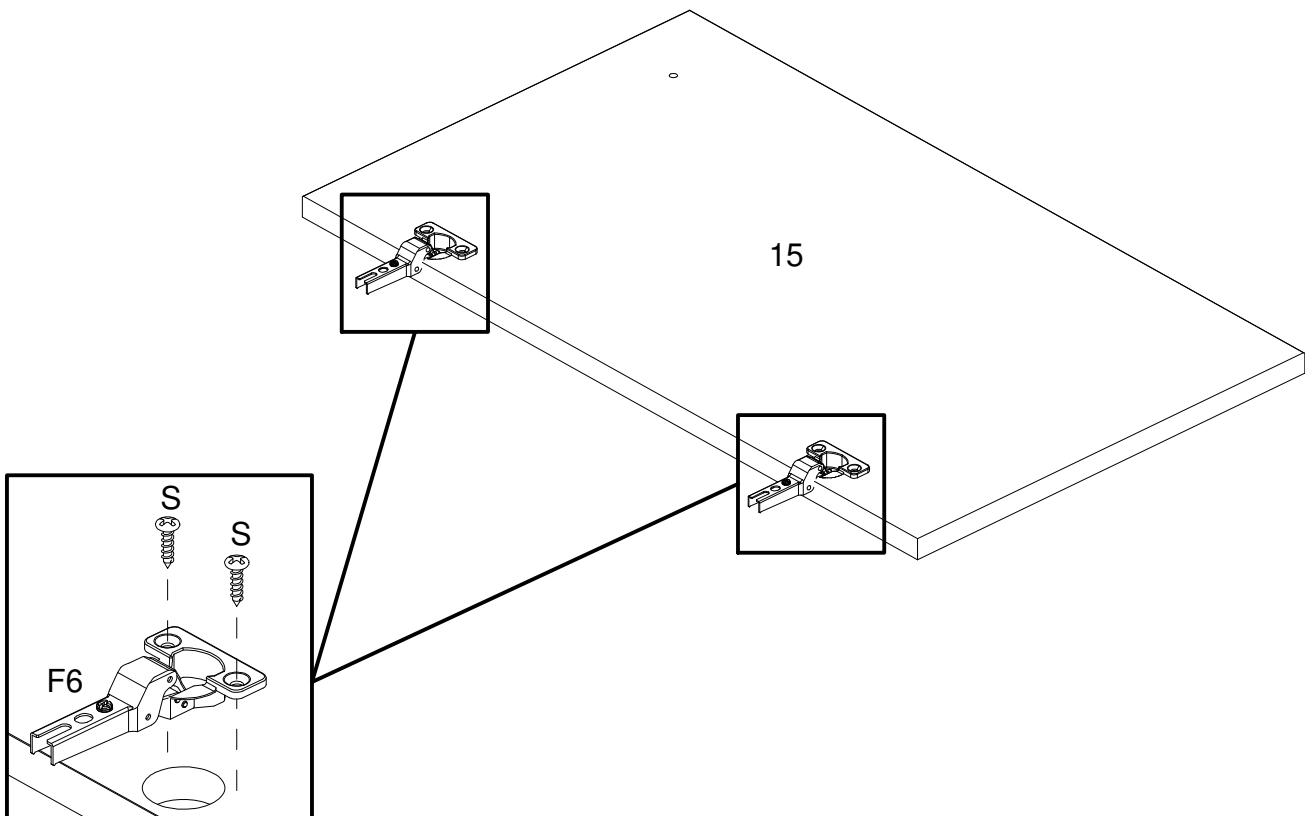

ASSEMBLY  
MONTAGEM / ARMADO

08

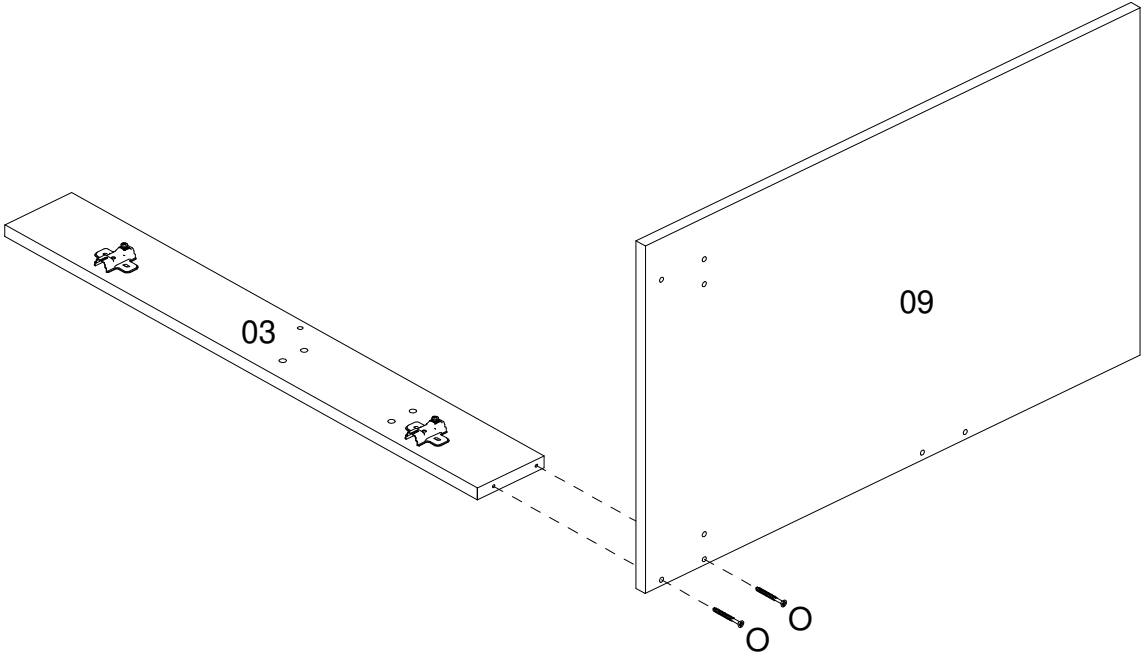

09

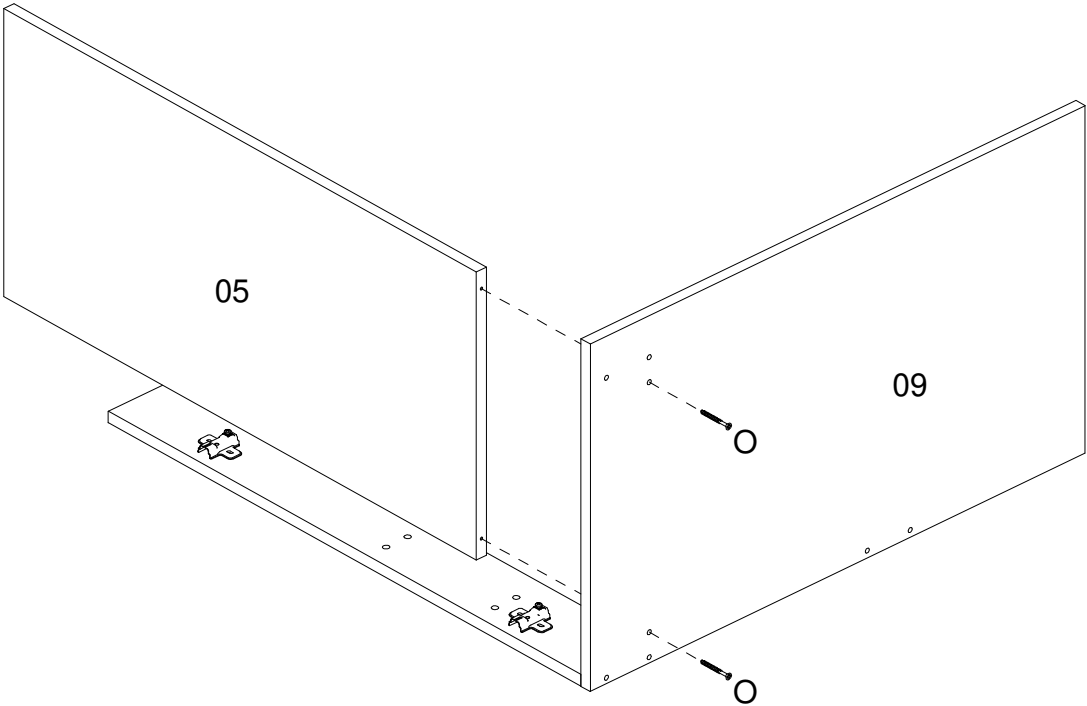

10

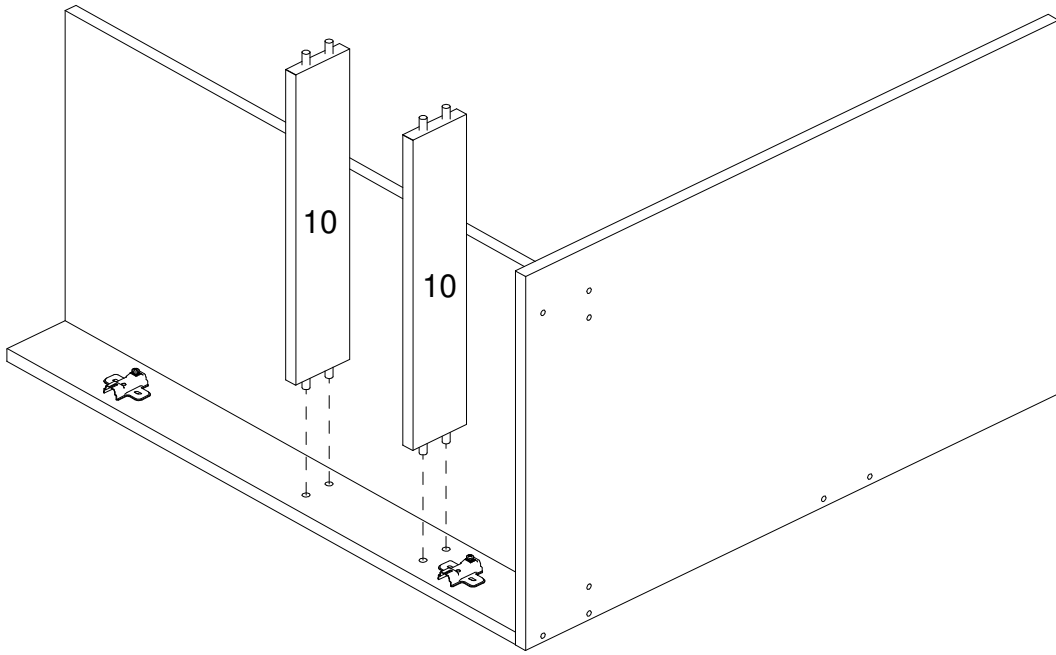

11

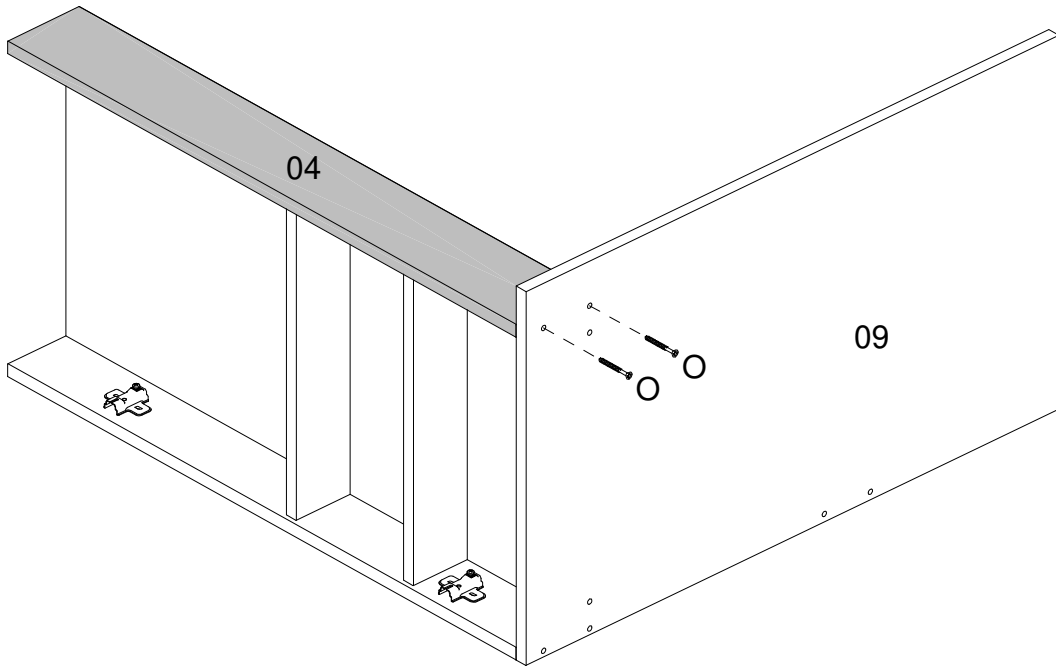



12

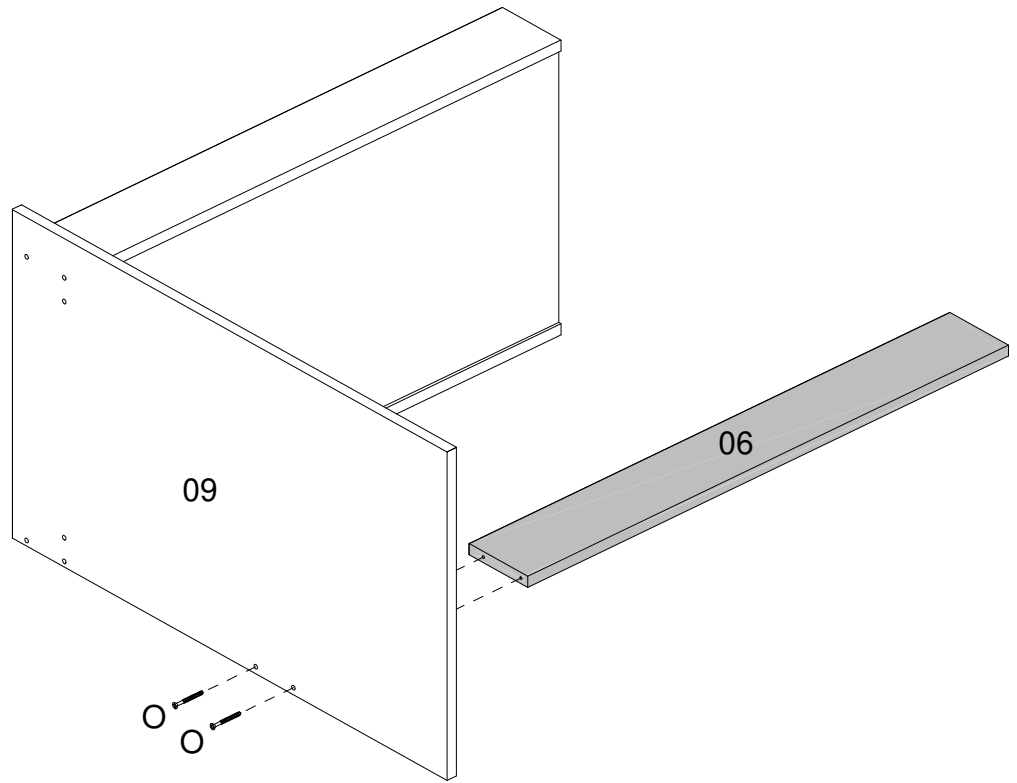

13

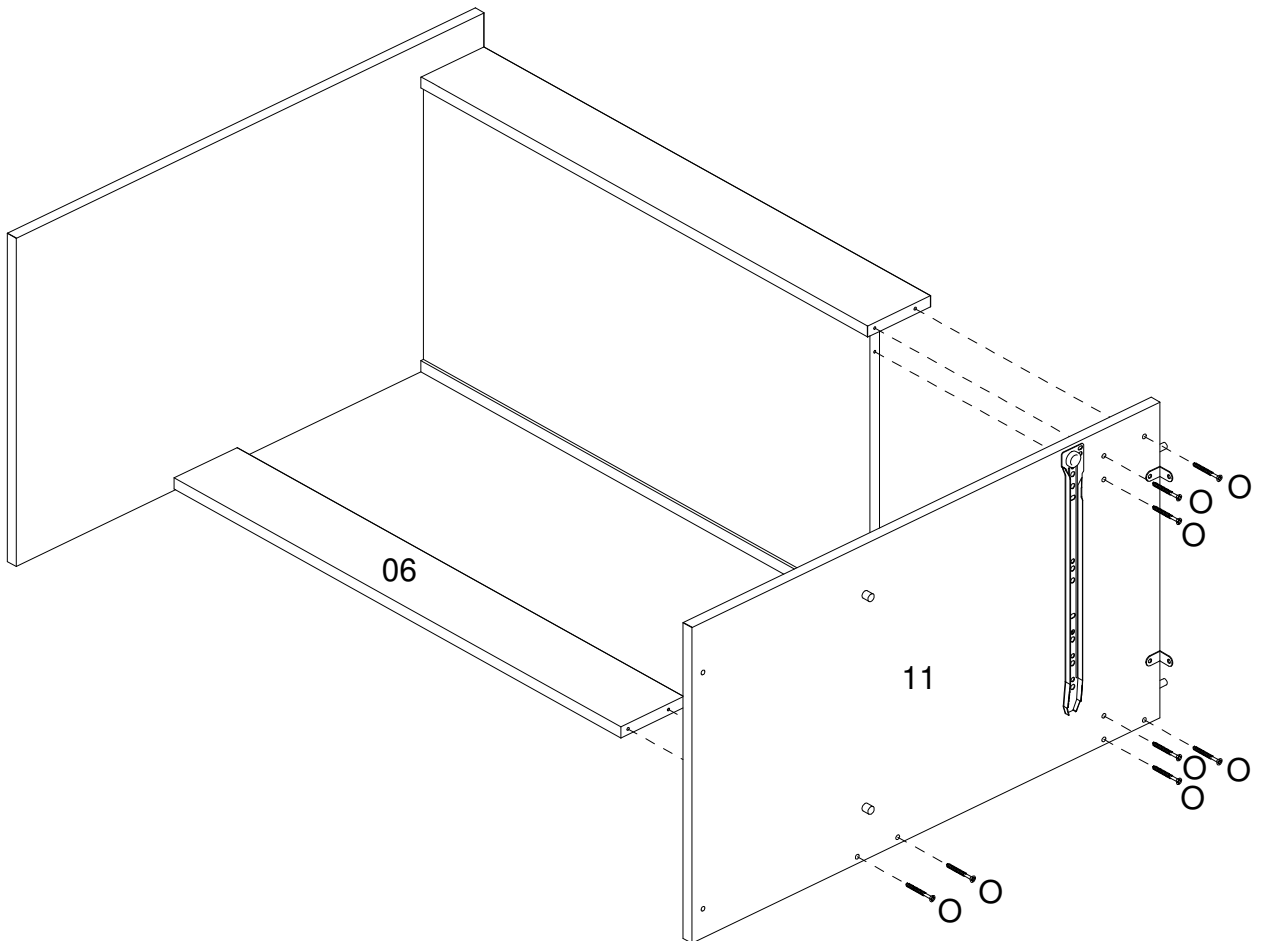

14

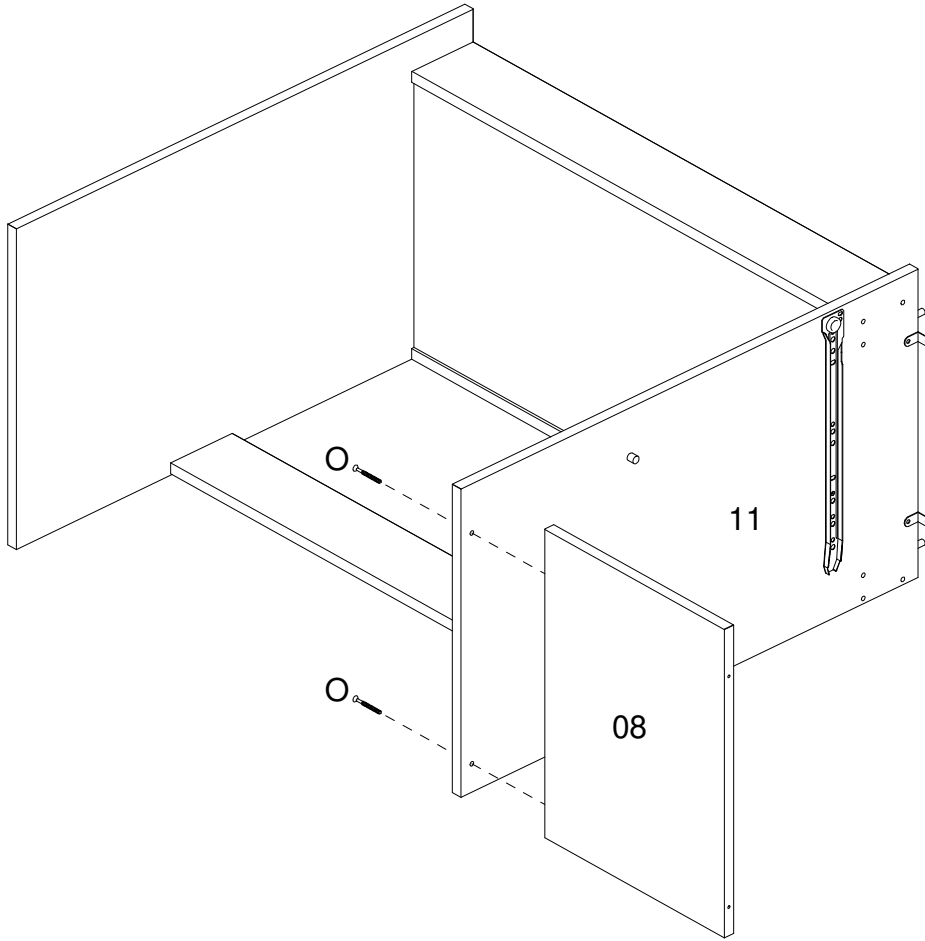

15

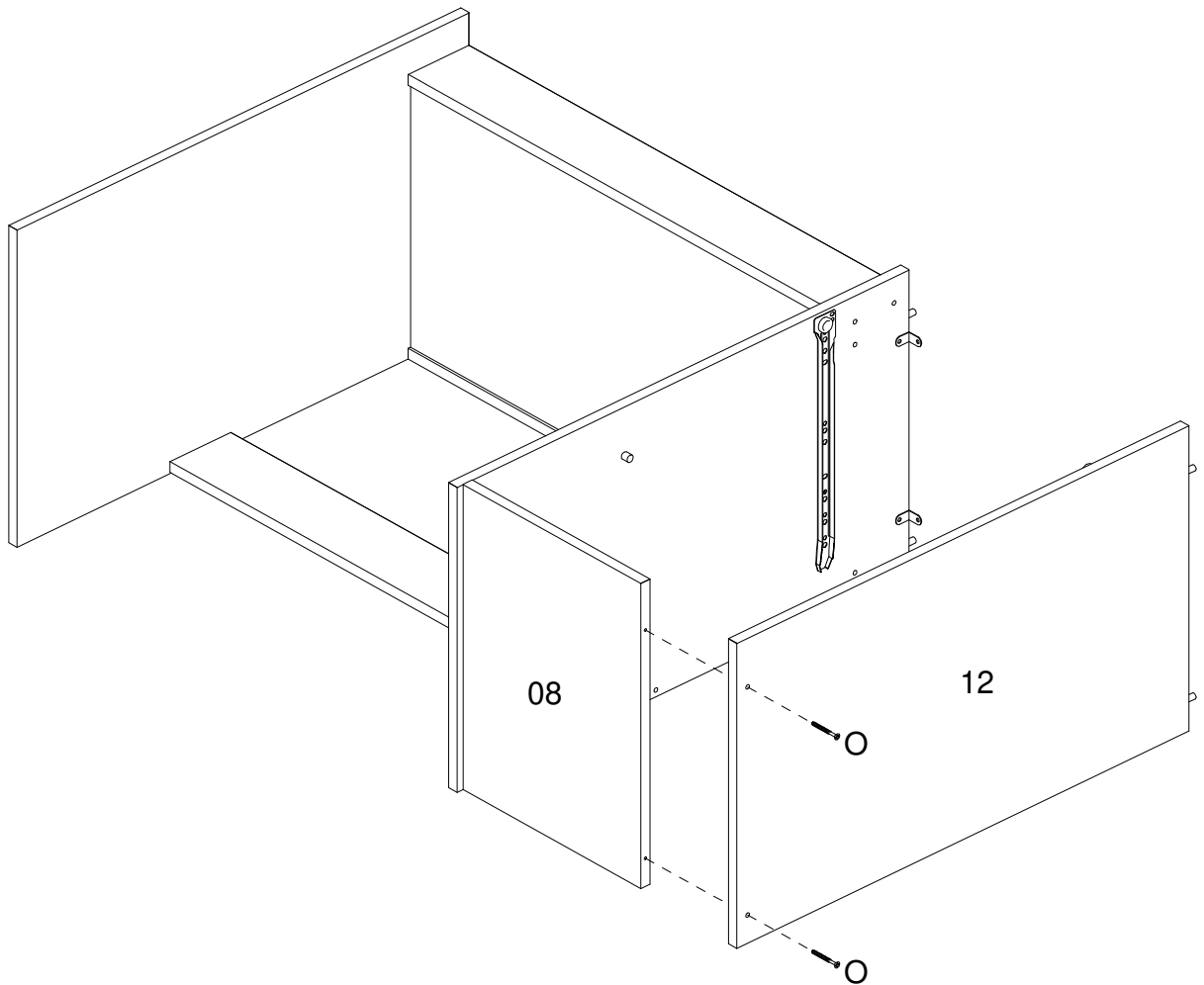

16

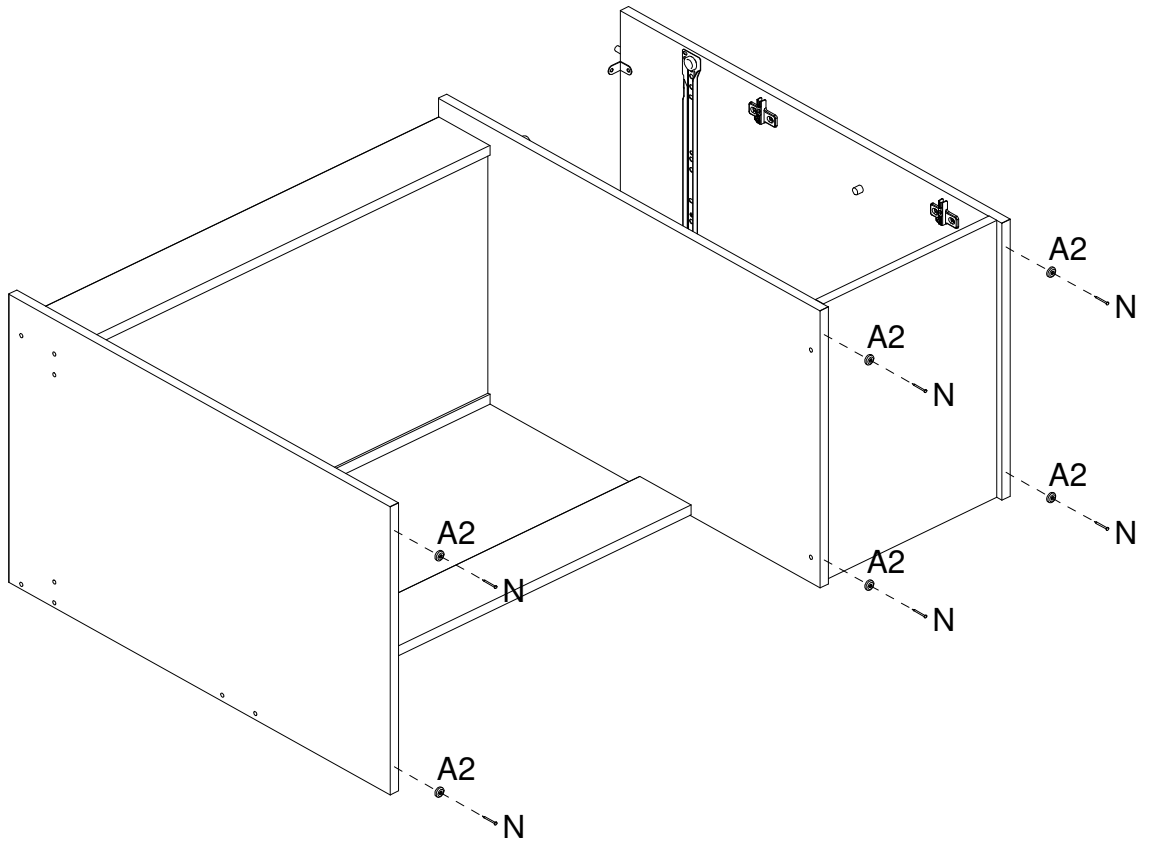

17

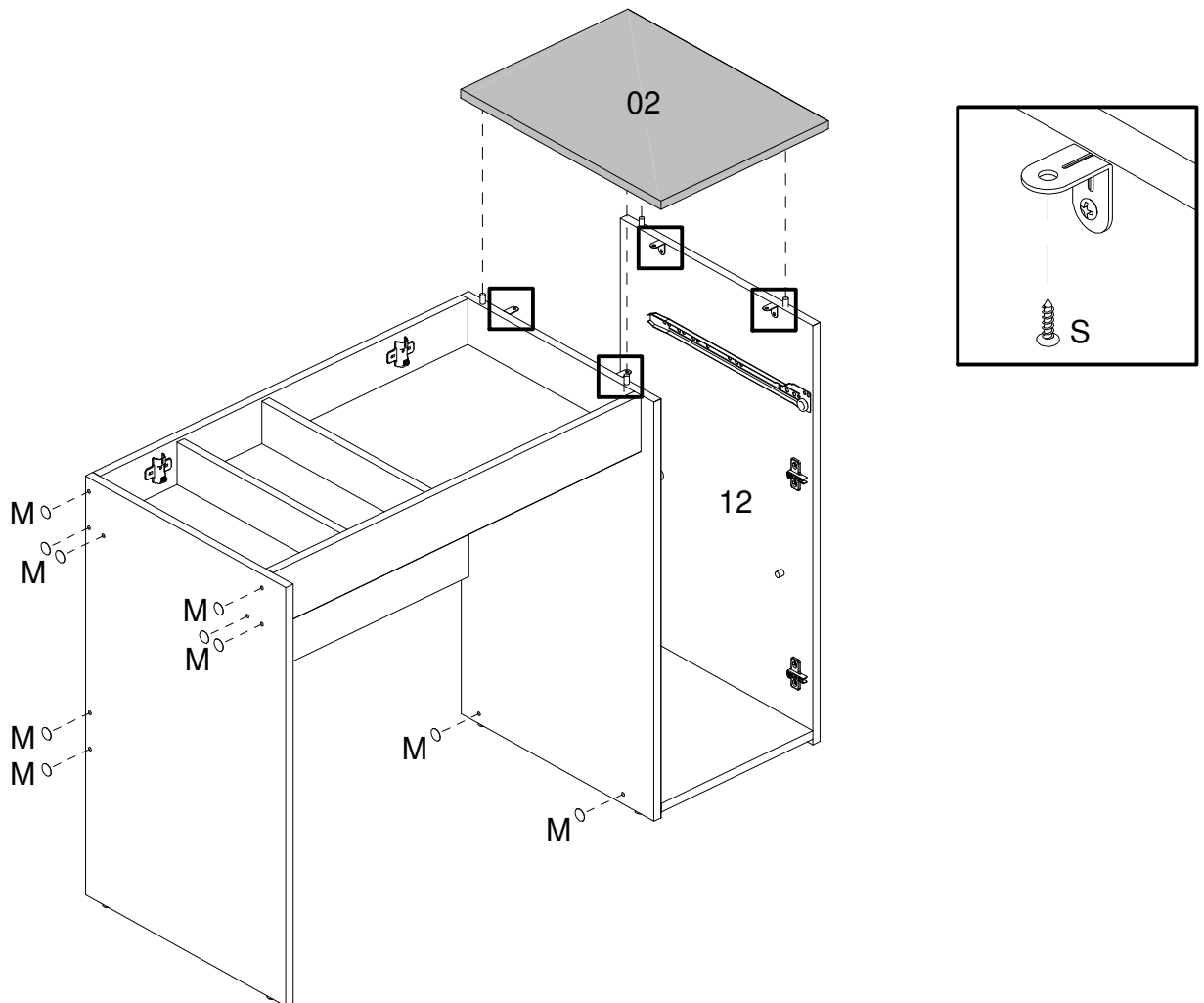

18

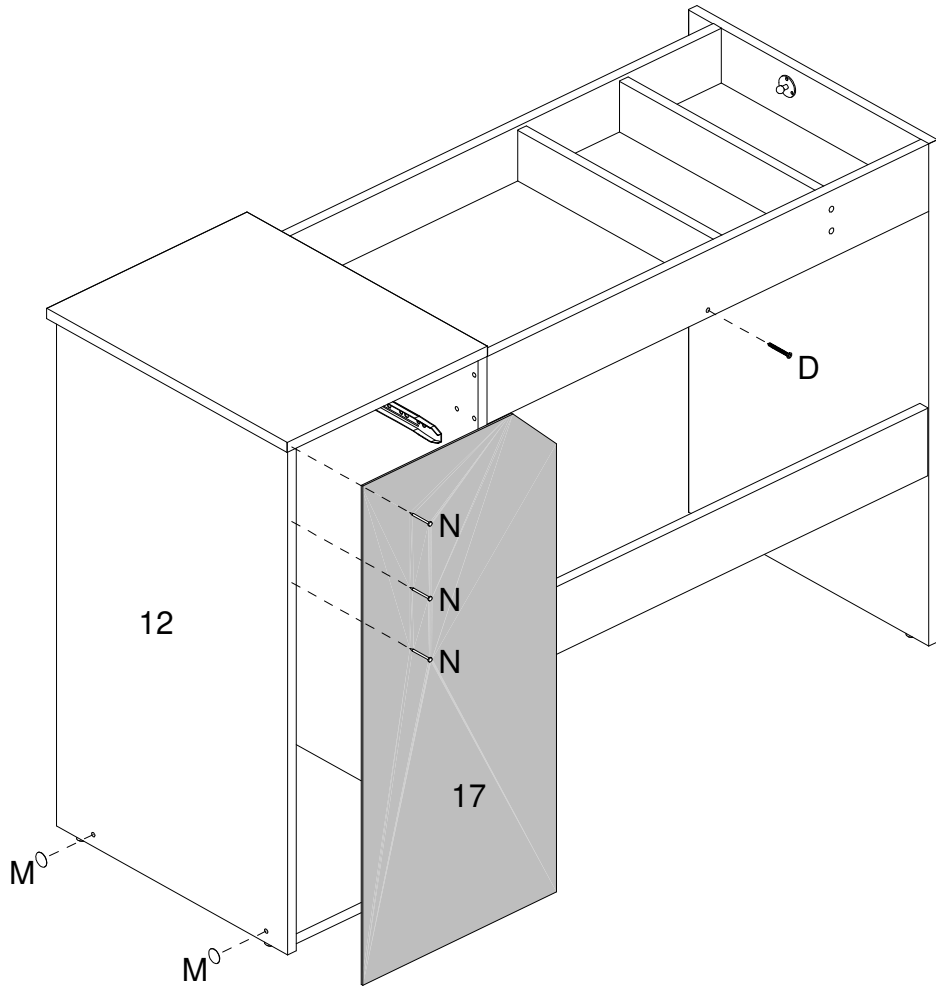

19

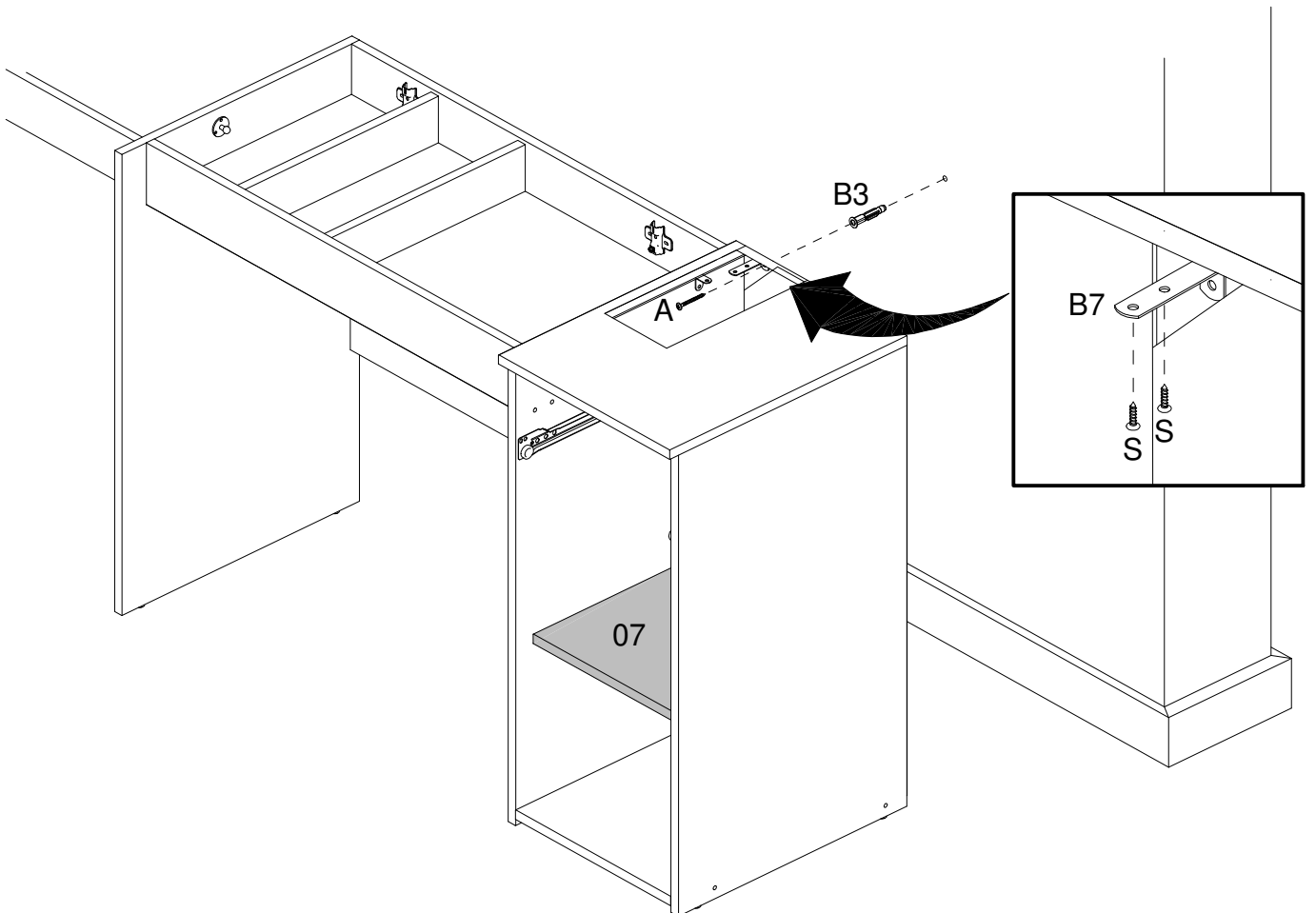

20

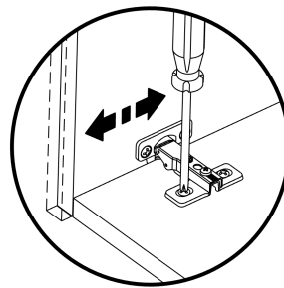
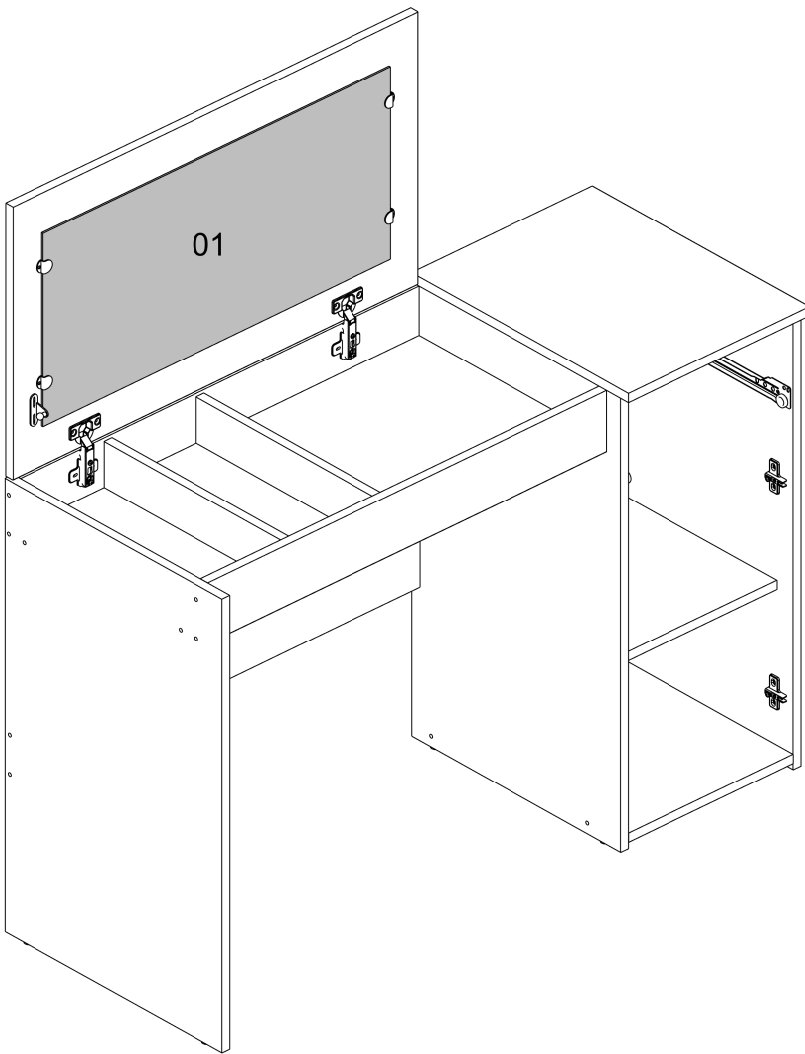

Horizontal Adjustment  
Regulagem Horizontal  
Ajuste Horizontal

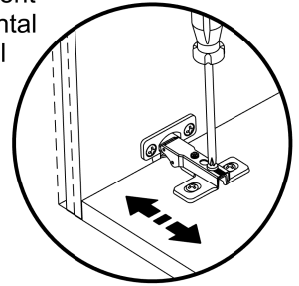

Vertical Adjustment  
Regulagem Vertical  
Ajuste Vertical

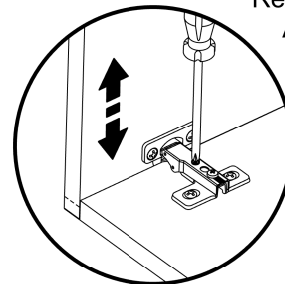

Depth Adjustment  
Regulagem Profundidade  
Ajuste Profundidad

21

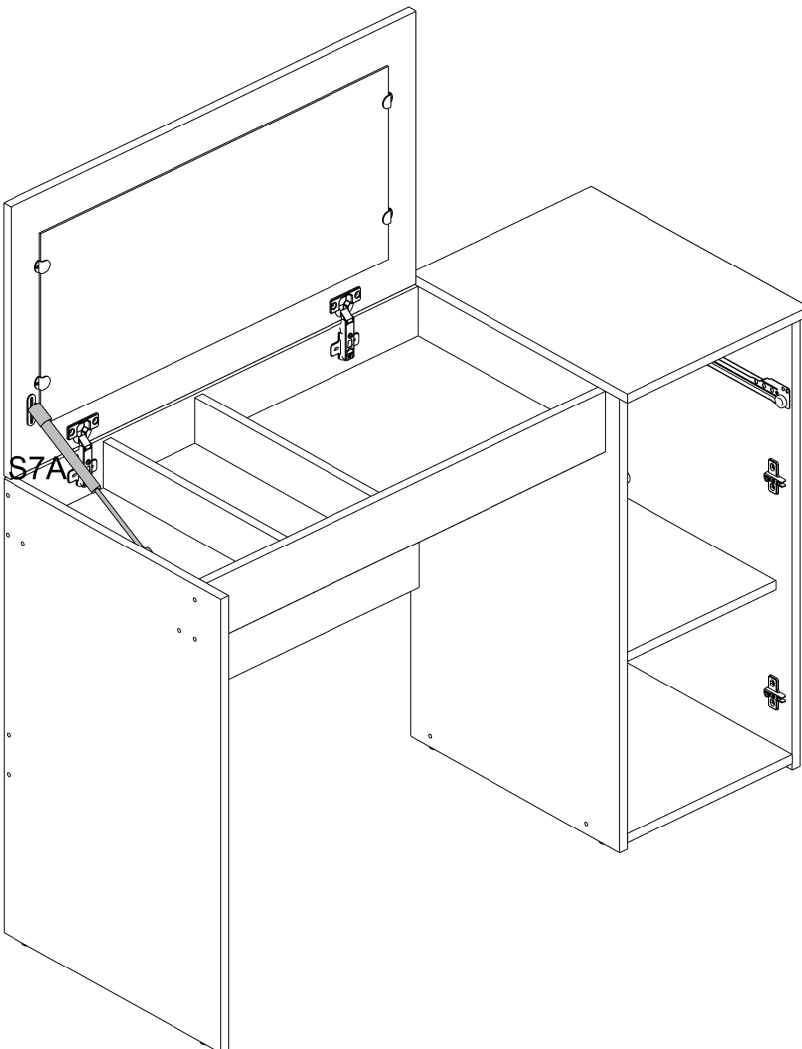

Follow the instruction corresponding to the template you received.  
Siga a instrução correspondente ao modelo que recebeu.  
Siga las instrucciones correspondientes al modelo que recibió.

Model 1 / Modelo 1

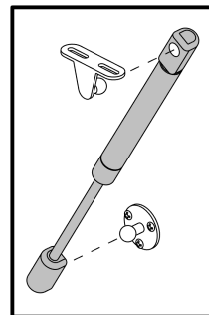

Model 2 / Modelo 2

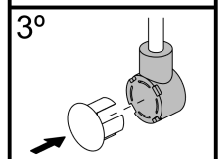
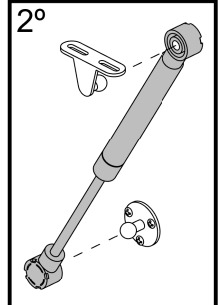
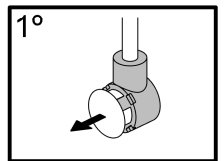

22

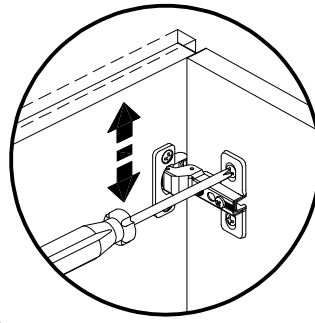
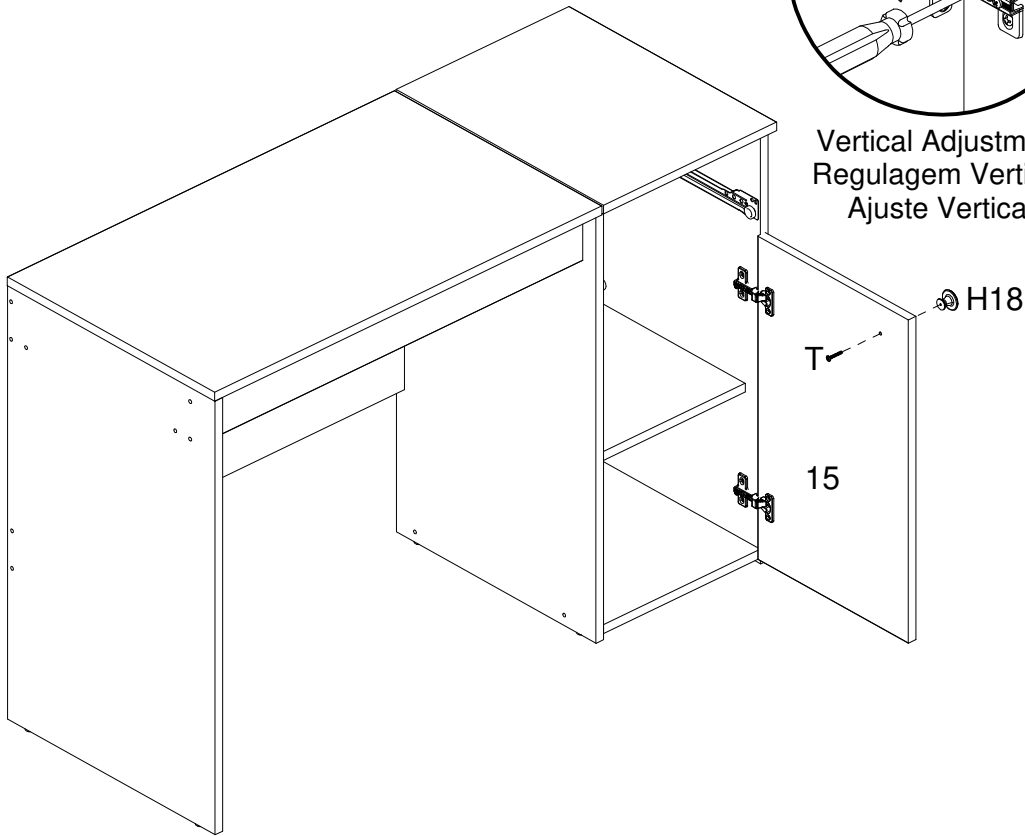

Vertical Adjustment  
Regulagem Vertical  
Ajuste Vertical

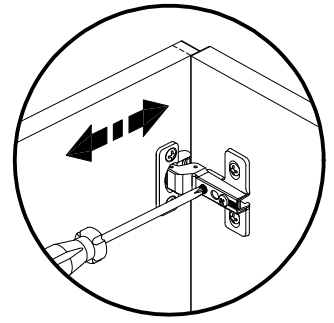

Horizontal Adjustment  
Regulagem Horizontal  
Ajuste Horizontal

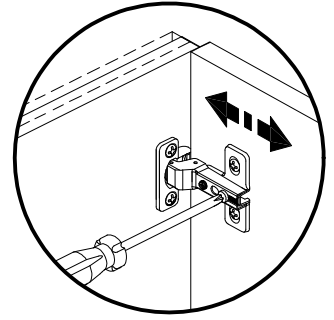

Depth Adjustment  
Regulagem Profundidade  
Ajuste Profundidad

23

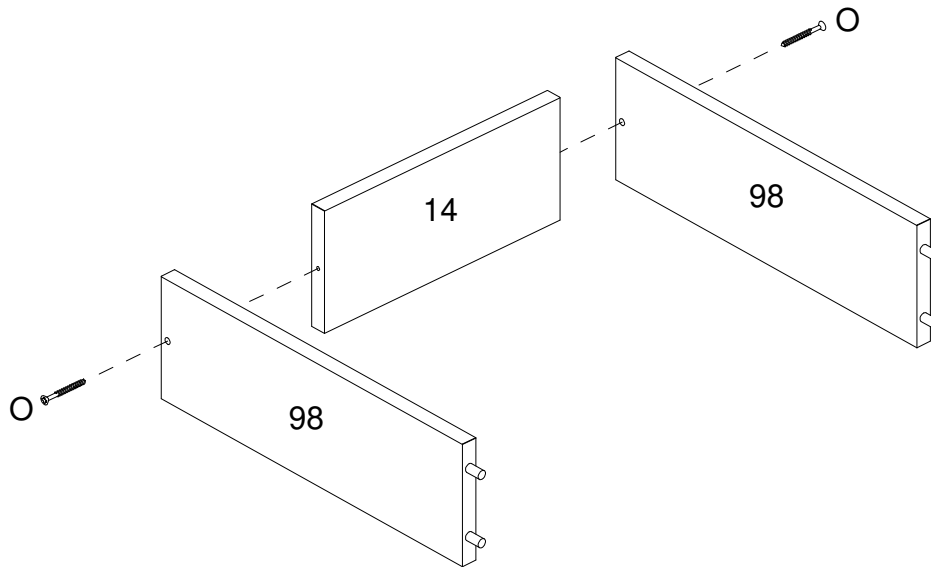

24

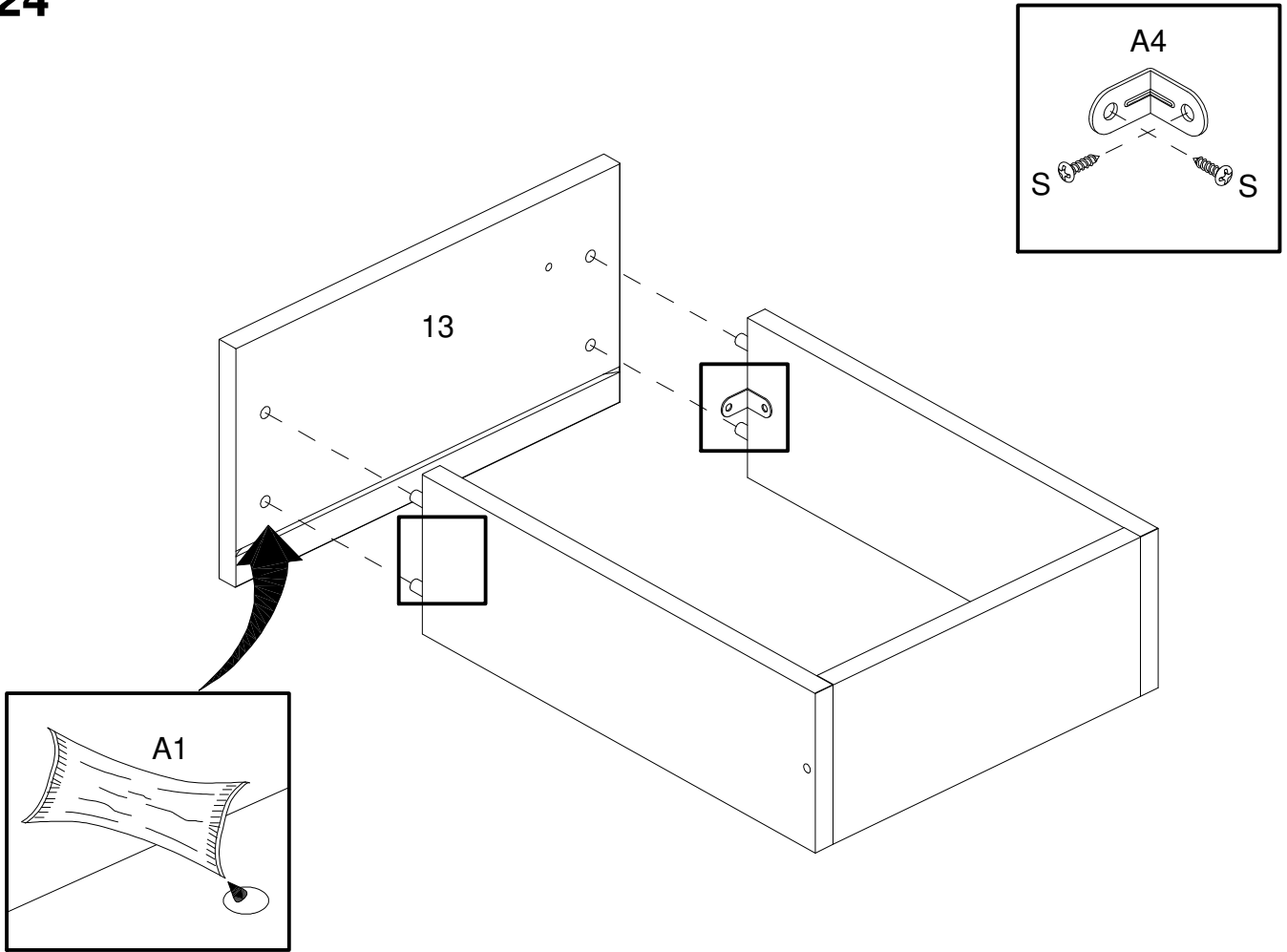

25

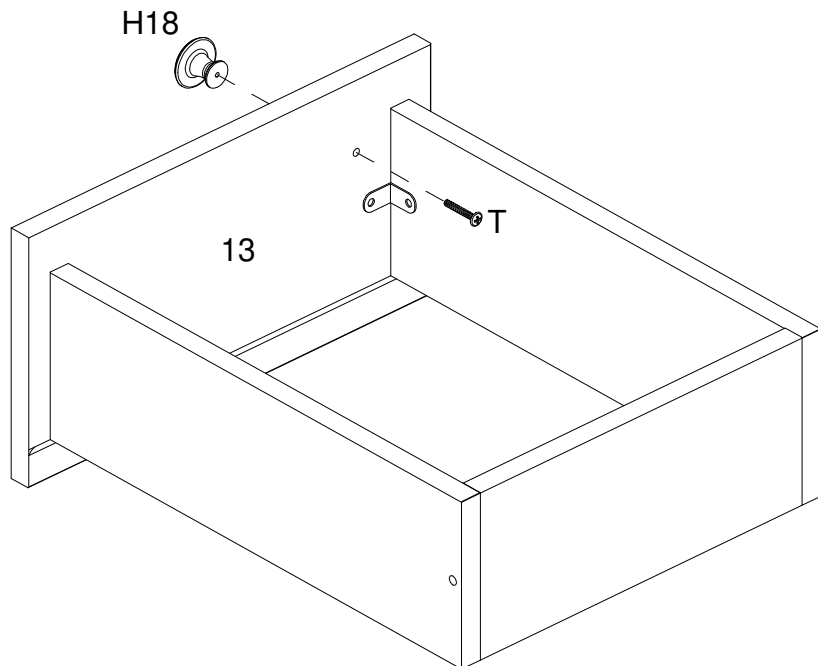

26

THE UNDERSIDE OF THE DRAWER  
LADO INFERIOR DA GAVETA  
PARTE INFERIOR DEL CAJÓN

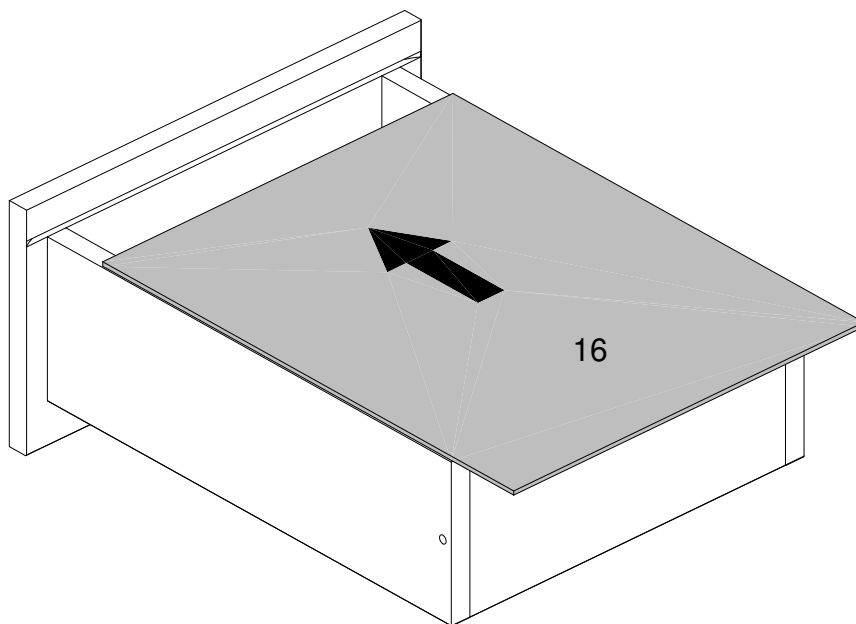

27

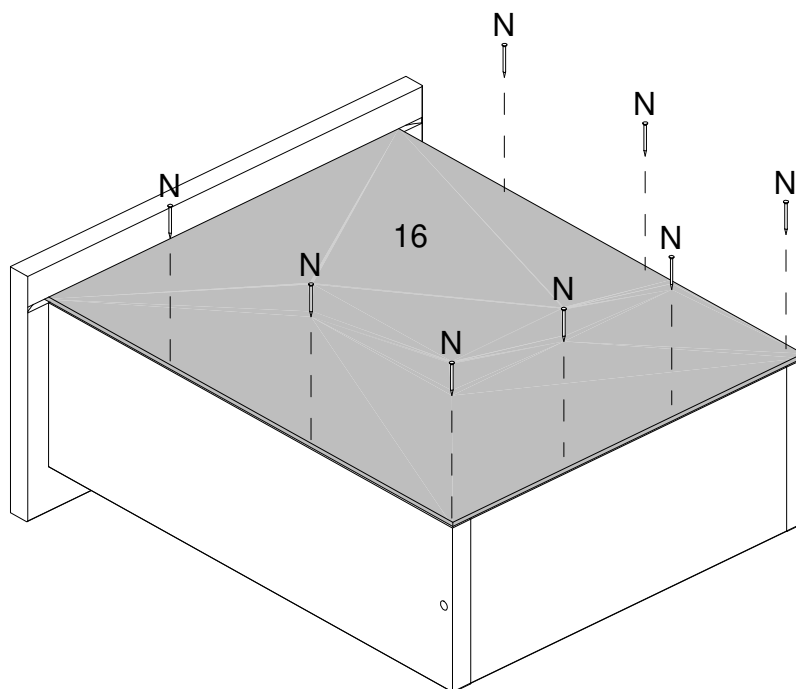



28

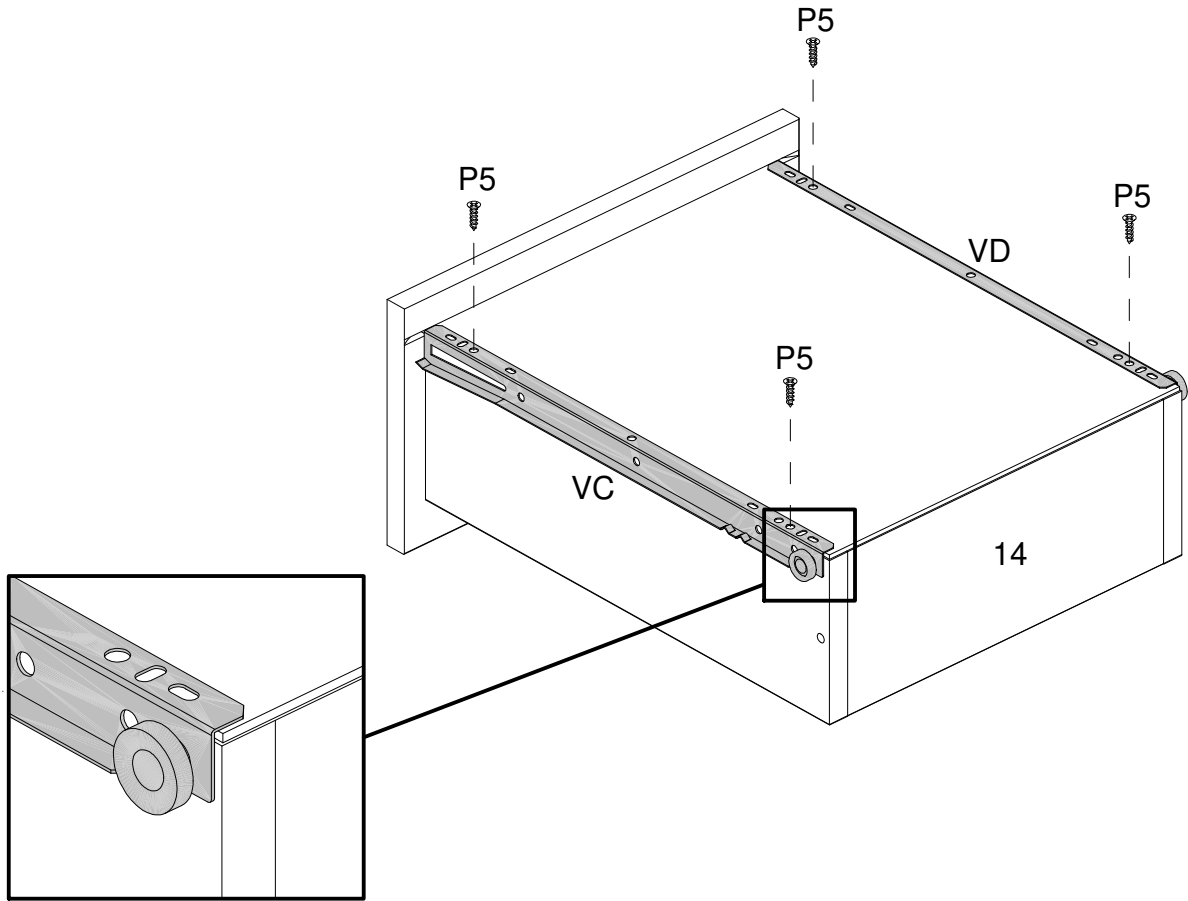

29

