

ASSEMBLY INSTRUCTIONS MANUAL DE MONTAGEM / INSTRUCCIONES DE ARMADO

LONDON OFFICE TABLE
MESA LONDON
ESCRITORIO LONDON

Reference 200512 | Revise 01
Referência 200512 | Revisão 01
Referencia 200512 | Revisión 01

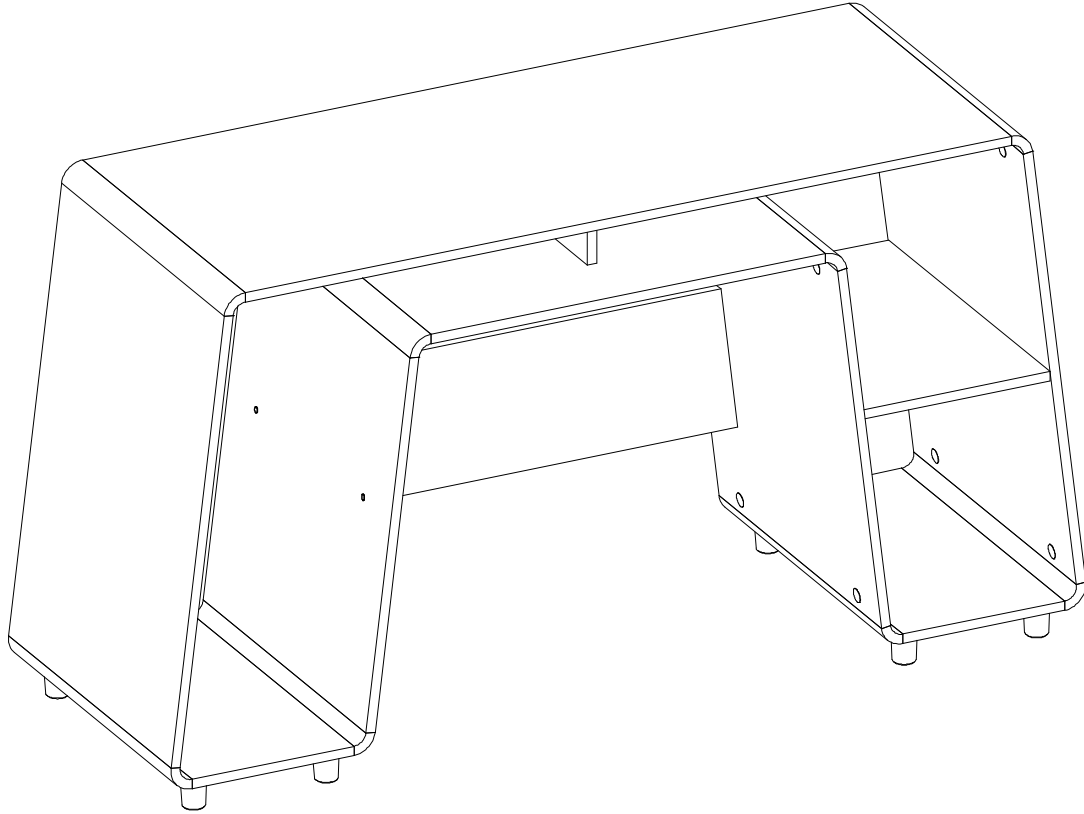

NOTES: THIS PRODUCT CAN BE ASSEMBLED WITH SHELF TO RIGHT OR LEFT.
NOTAS: ESTE PRODUTO PODE SER MONTADO COM A PRATELEIRA PARA A SUA DIREITA OU ESQUERDA.
NOTAS: ESTE PRODUCTO PUEDE SER ARMADO CON LA REPISA PARA LA DERECHA O LA IZQUIERDA.

YOU WILL NEED / VOCÊ VAI PRECISAR DE / USTED NECESITARÁ

Tools not supplied / Ferramentas não fornecidas / Herramientas no incluidas

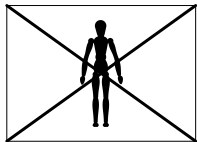

1 Person
1 Pessoa
1 Persona

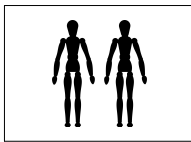

2 People
2 Pessoas
2 Personas

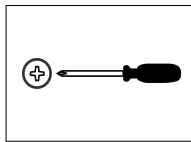

Screwdriver Phillips
Chave Phillips
Destornillador cruz

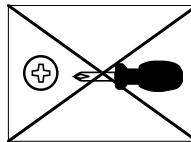

Small screwdriver Philips
Chave Phillips menor
Destornillador cruz menor

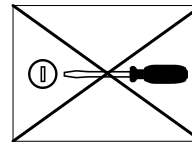

Screwdriver slotted
Chave fenda
Destornillador plano

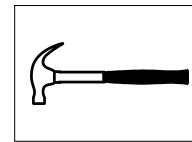

Hammer
Martelo
Martillo

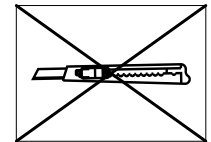

Stylet
Estilete
Estilete

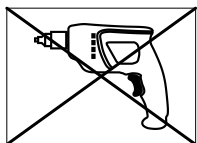

Drill machine
Furadeira
Taladro

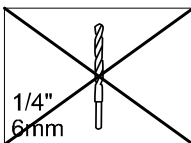

1/4"
6mm
Drill bit
Broca
Taladro

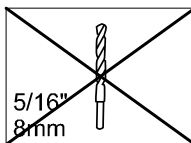

5/16"
8mm
Drill bit
Broca
Taladro

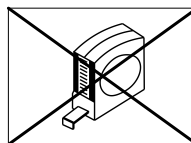

Measuring tape
Trena
Cinta de medición

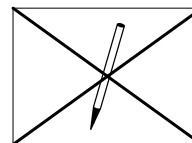

Pencil
Lápis
Lápis

NOTES: The separation of the accessories before you start the assembly will facilitate the same. In case of doubt on the size of the screws and bolts, use the ruler to bottom of page 3.

NOTAS: A separação dos acessórios antes de iniciar a montagem facilitará a mesma. Em caso de dúvida no tamanho dos parafusos e cavilhas, utilize a régua ao final da página 3.

NOTAS: La separación de los accesorios antes de comenzar el armado facilitará el mismo. En caso de duda sobre el tamaño de los tornillos y taquetes, utilice la regla al pie de página 3.

MAXIMUM RECOMMENDED WEIGHT
BEING THIS EVENLY DISTRIBUTED

PESO MÁXIMO RECOMENDADO SENDO
ESTE DISTRIBUÍDO UNIFORMEMENTE

PESO MÁXIMO RECOMENDADO SIENDO
ESTE UNIFORMEMENTE DISTRIBUIDO

	LB	KG
C	6	3
D	11	5
F	22	10
G	33	15

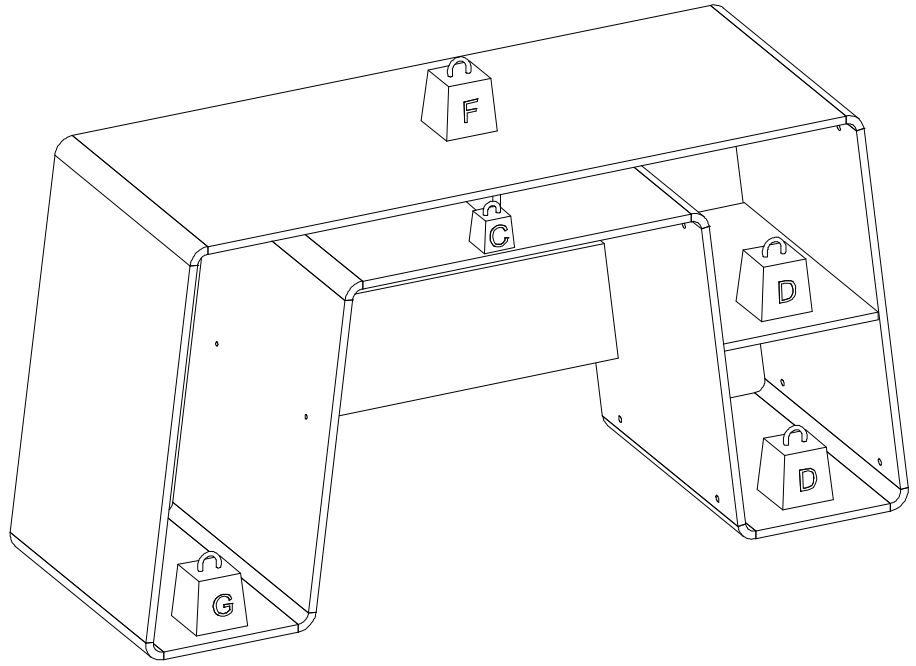





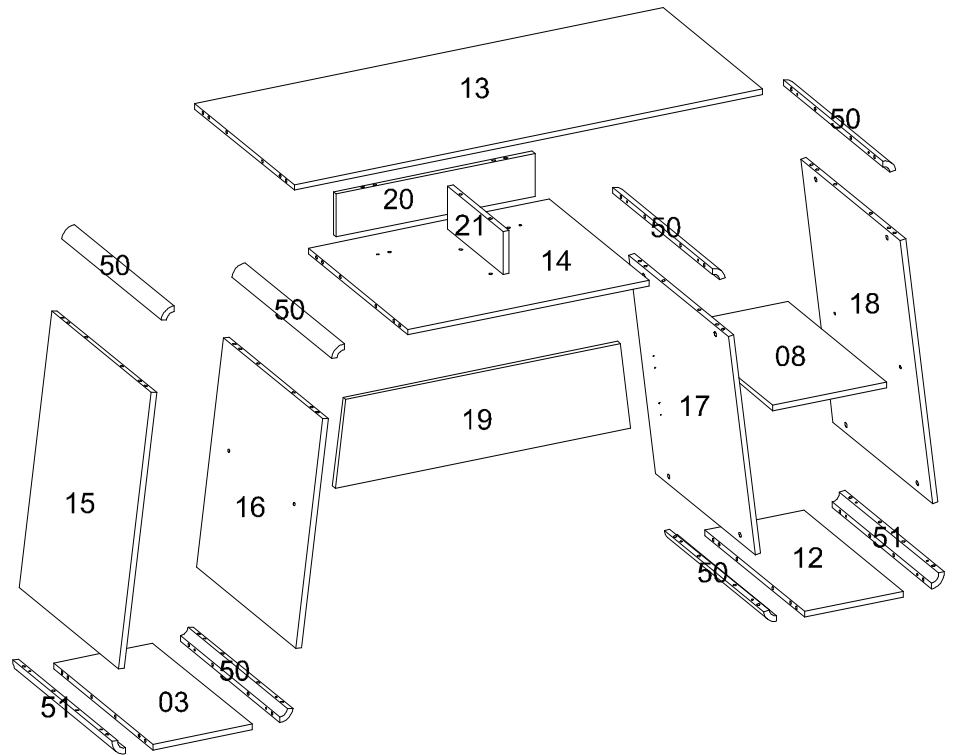



Nº	Measures_Inches	Medidas_cm	Qty./Qtd.
03	21 1/8 x 10 1/2 x 5/8	53.5 x 26.6 x 1.5	1
08	20 7/8 x 12 x 5/8	53.0 x 30.6 x 1.5	1
12	21 1/8 x 10 1/2 x 5/8	53.5 x 26.6 x 1.5	1
13	21 1/8 x 49 5/8 x 5/8	53.5 x 126.0 x 1.5	1
14	21 1/8 x 25 1/2 x 5/8	53.5 x 64.9 x 1.5	1
15	21 1/8 x 28 1/4 x 5/8	53.5 x 71.6 x 1.5	1
16	21 1/8 x 23 3/8 x 5/8	53.5 x 59.4 x 1.5	1
17	21 1/8 x 23 3/8 x 5/8	53.5 x 59.4 x 1.5	1
18	21 1/8 x 28 1/4 x 5/8	53.5 x 71.6 x 1.5	1
19	9 x 31 1/4 x 5/8	22.8 x 79.5 x 1.5	1
20	4 1/2 x 21 1/8 x 5/8	11.3 x 53.5 x 1.5	1
21	4 1/2 x 11 3/4 x 5/8	11.3 x 30.0 x 1.5	1
50	21 1/8 x 1 3/8 x 1 1/4	53.5 x 3.5 x 3.3	6
51	21 1/8 x 1 3/8 x 1 1/2	53.5 x 3.5 x 3.9	2
-	3 x 1/4 x	7.5 x 0.7 x 0.0	1

PARTS IDENTIFICATION
IDENTIFICAÇÃO DAS PEÇAS / IDENTIFICACIÓN DE LAS PIEZAS

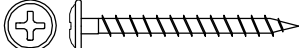
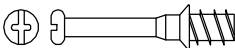

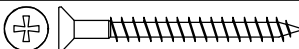
IDENTIFICATION OF ACCESSORIES IDENTIFICAÇÃO DOS ACESSÓRIOS/ IDENTIFICACIÓN DE ACCESORIOS

A1		Glue / Cola / Pegamento	13 g	4
B5		Metalic angle plates / Cantoneira de metal / Suporte de metal	46 mm	4
E		Wooden dowel / Cavilha / Taquete	8x30 mm	72
E3		Shelf bracket / Suporte de prateleira / Suporte de repisa	8x7 mm	4
E8		Plastic foot / Pé de rack / Pie plástico	50 mm	8
G3		Flanged head screw / Parafuso flangeado / Tornillo de cabeza flangeada	5,0x40 mm	8
J		Simple minifix screw / Haste minifix simples / Tornillo minifix simple	-	34
L		Drum lock / Tambor minifix / Tambor minifix	12 mm	34
M		Bore patch adhesive / Tapa furo adesivo / Tapones adhesivo	-	16
O		Flat head screw / Parafuso chato / Tornillo de cabeza plana	4,5x45 mm	2
S		Pan head screw / Parafuso panela / Tornillo de pan	3,5x14 mm	16
Z		Plastic hole plugs / Tapa furo plástico / Tapones plásticos	8 mm	4



PRE-ASSEMBLE
PRÉ-MONTAGE / PRE ARMADO

01

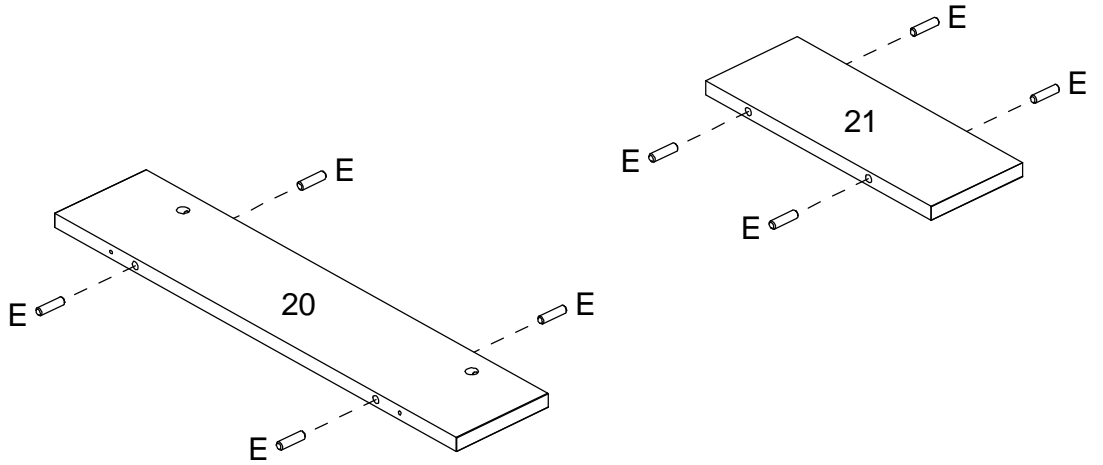
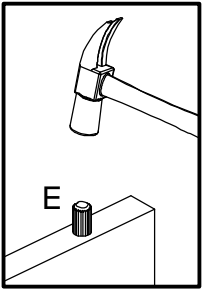

02

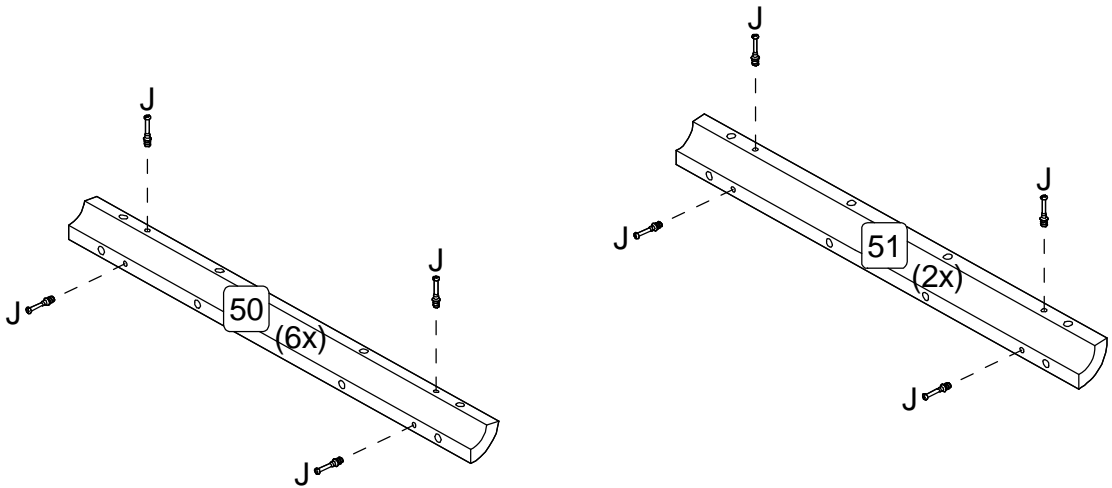
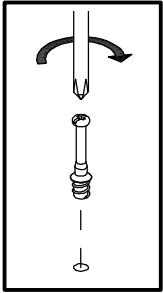

03

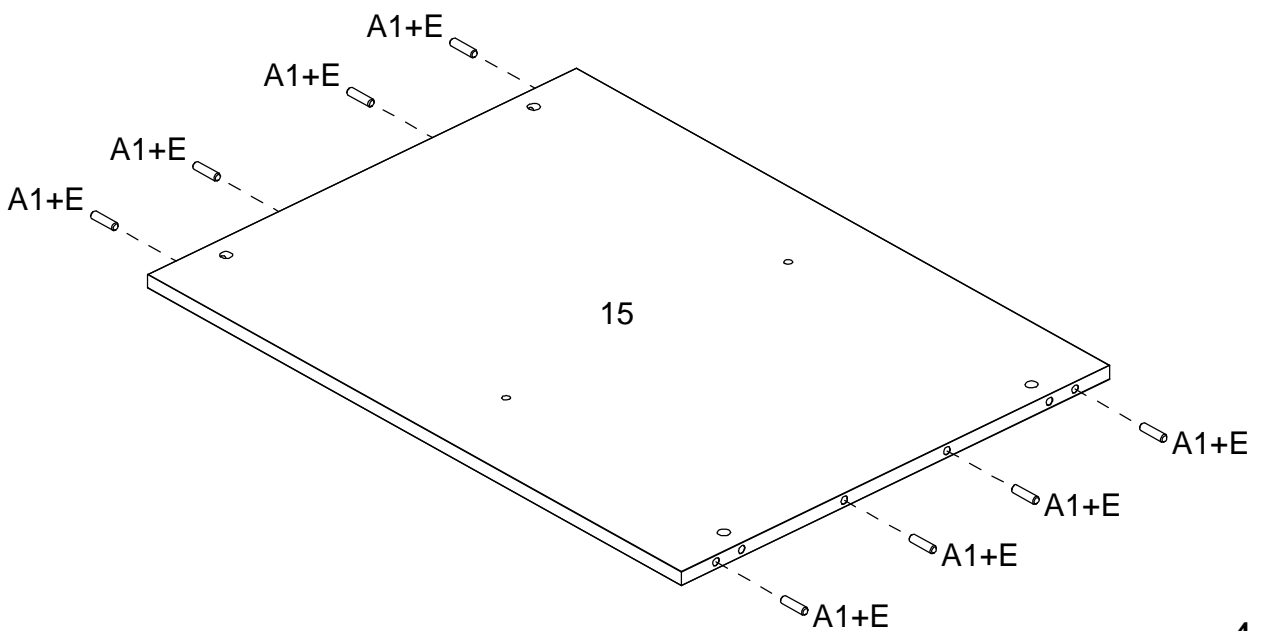
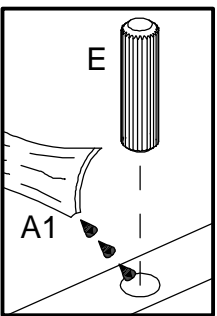

04

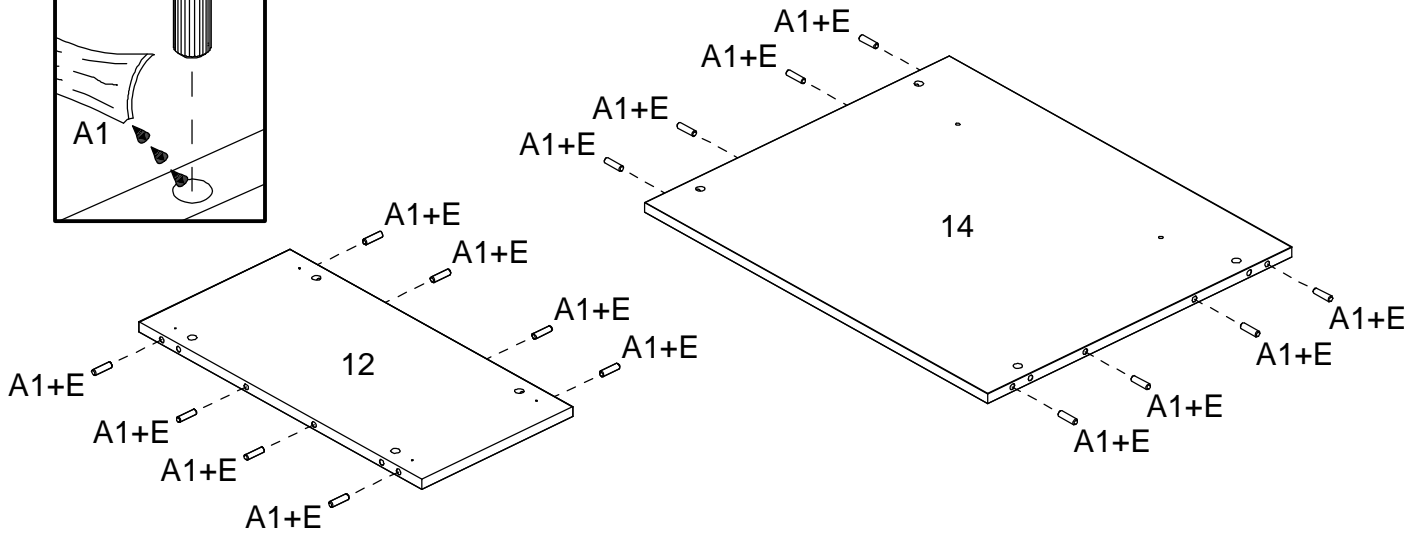
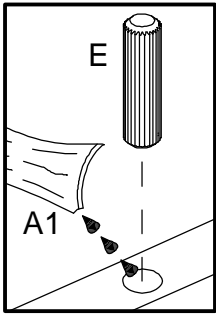

05

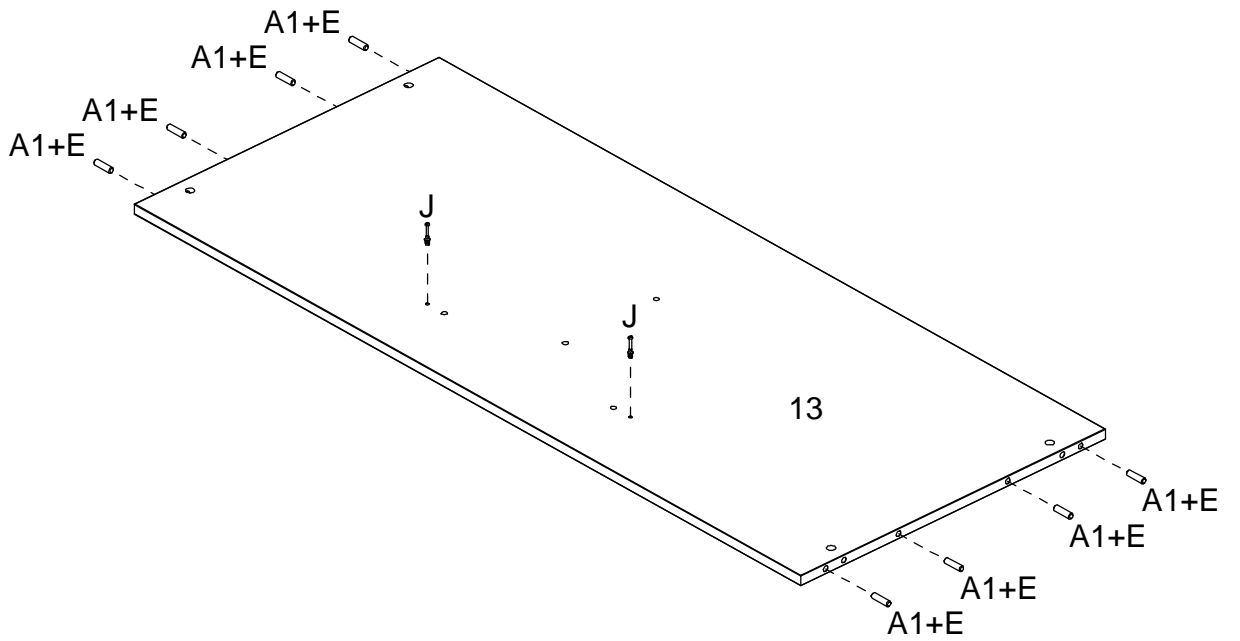
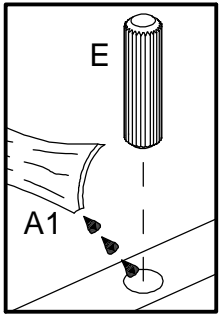

06

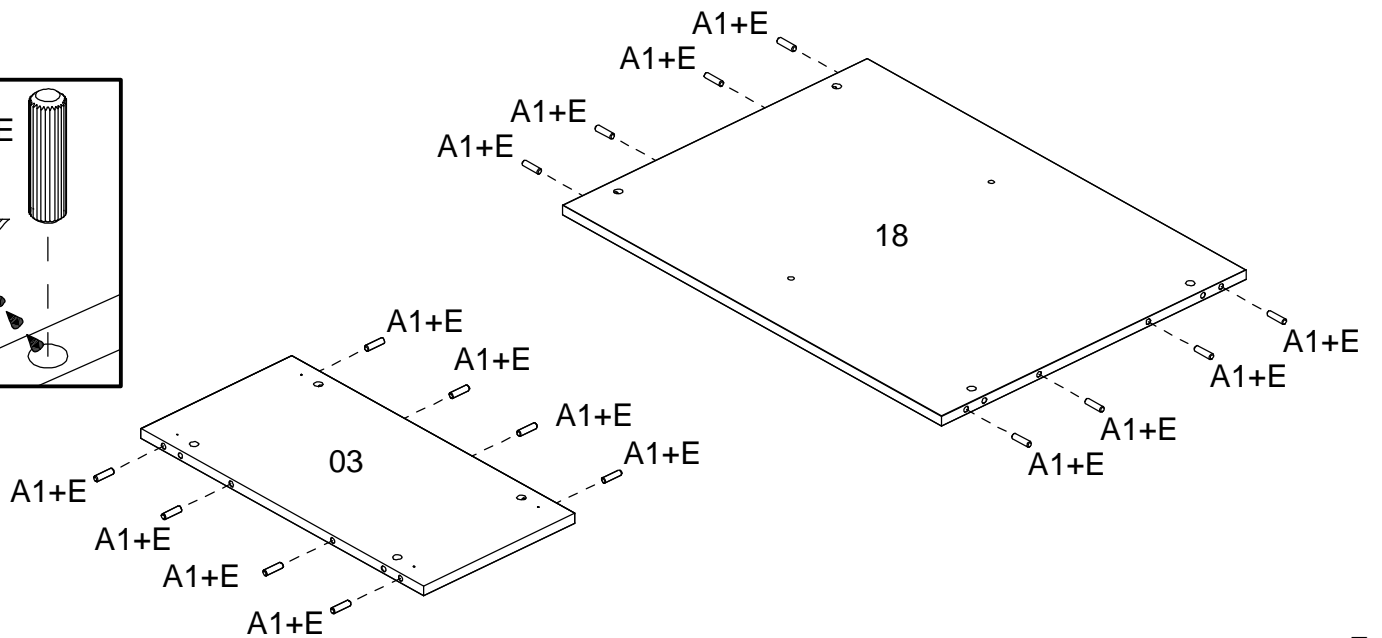
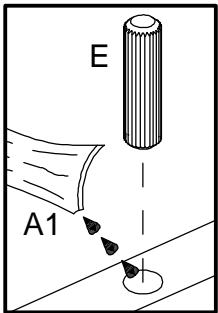

07

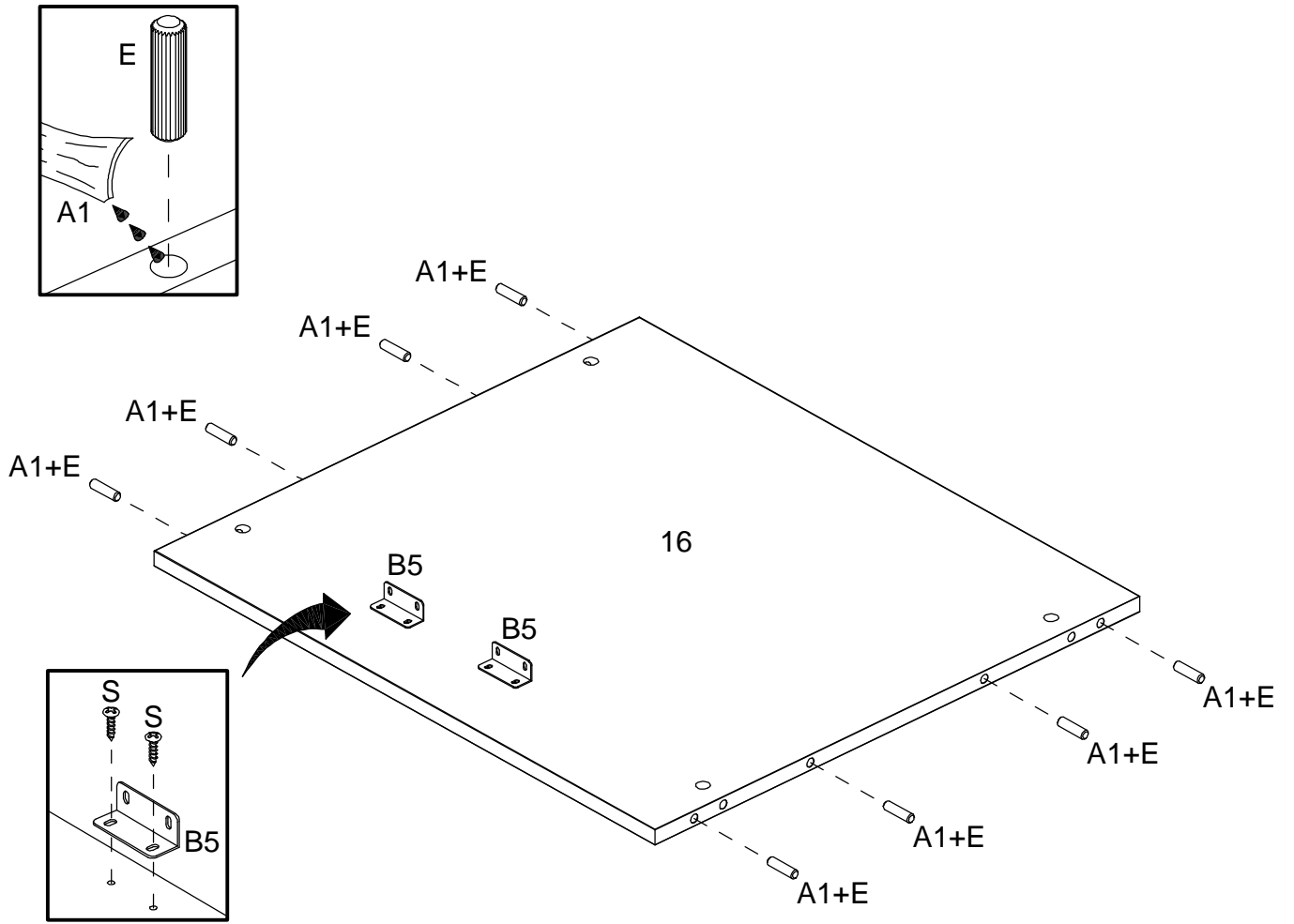

08

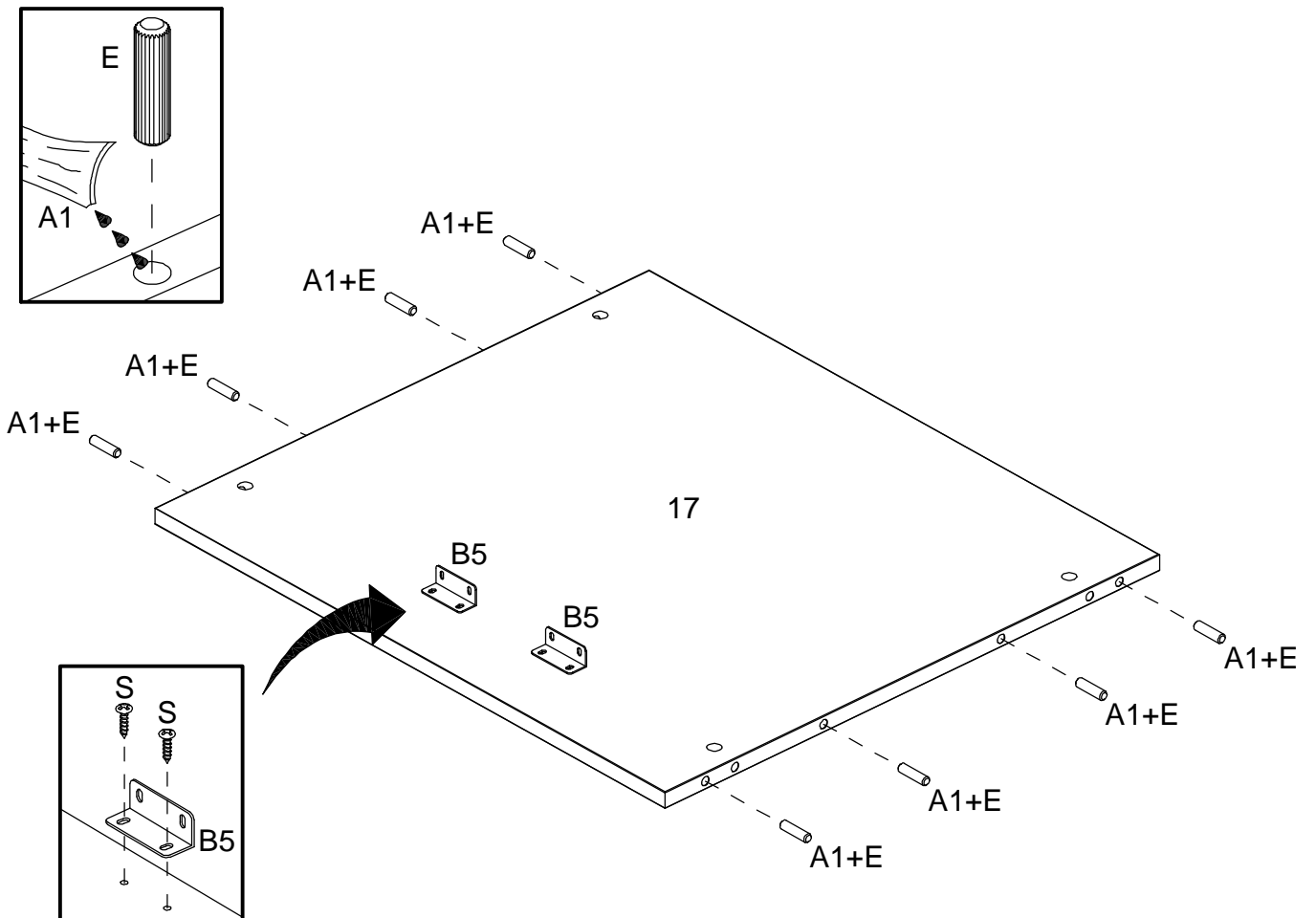

ASSEMBLY
MONTAGEM / ARMADO

09

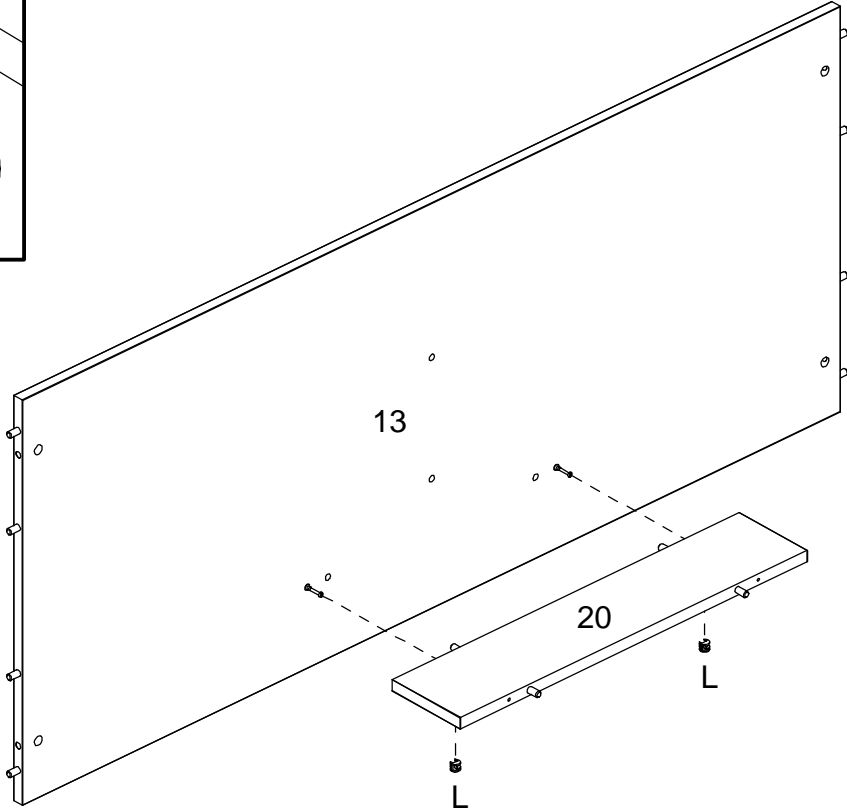
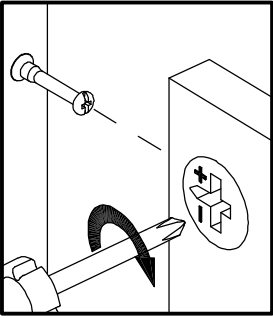

10

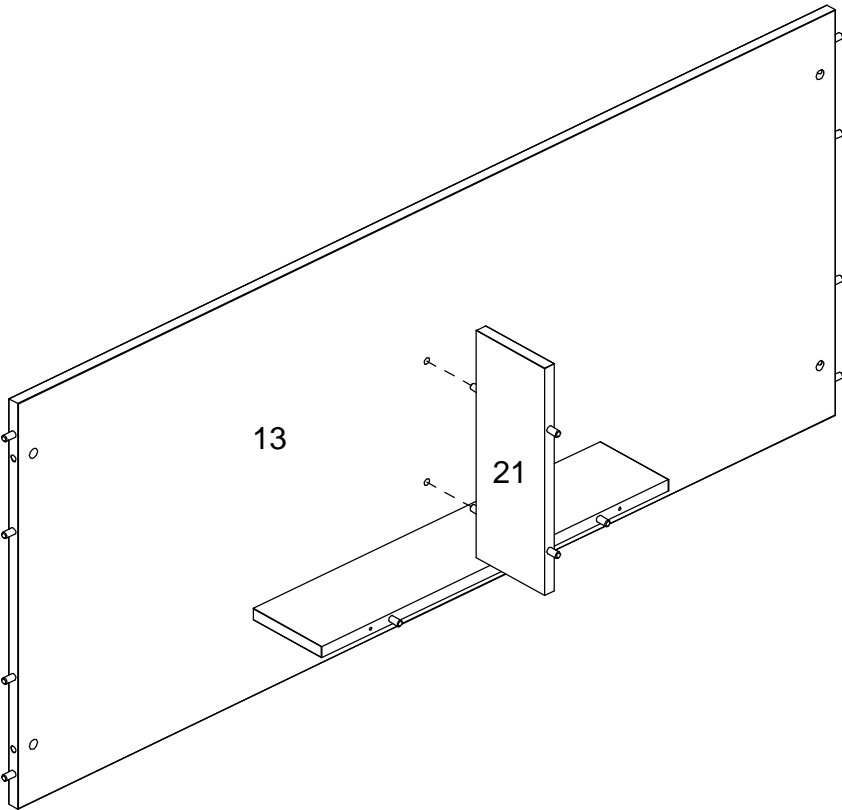

11

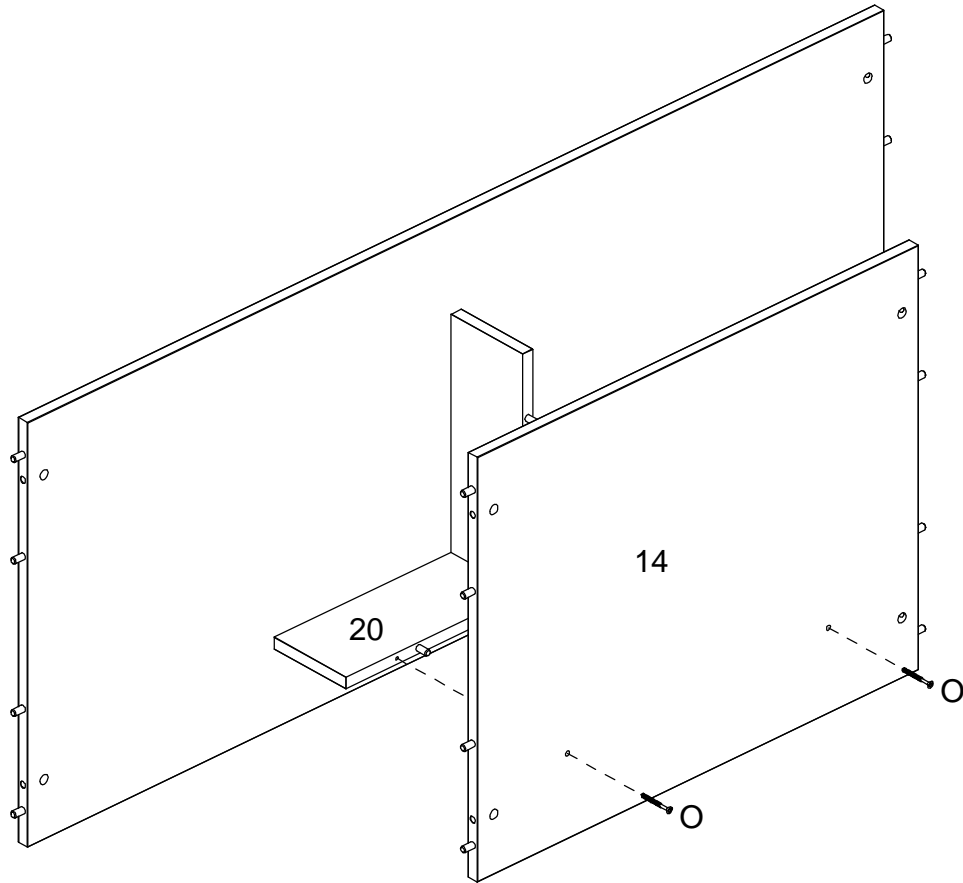

12

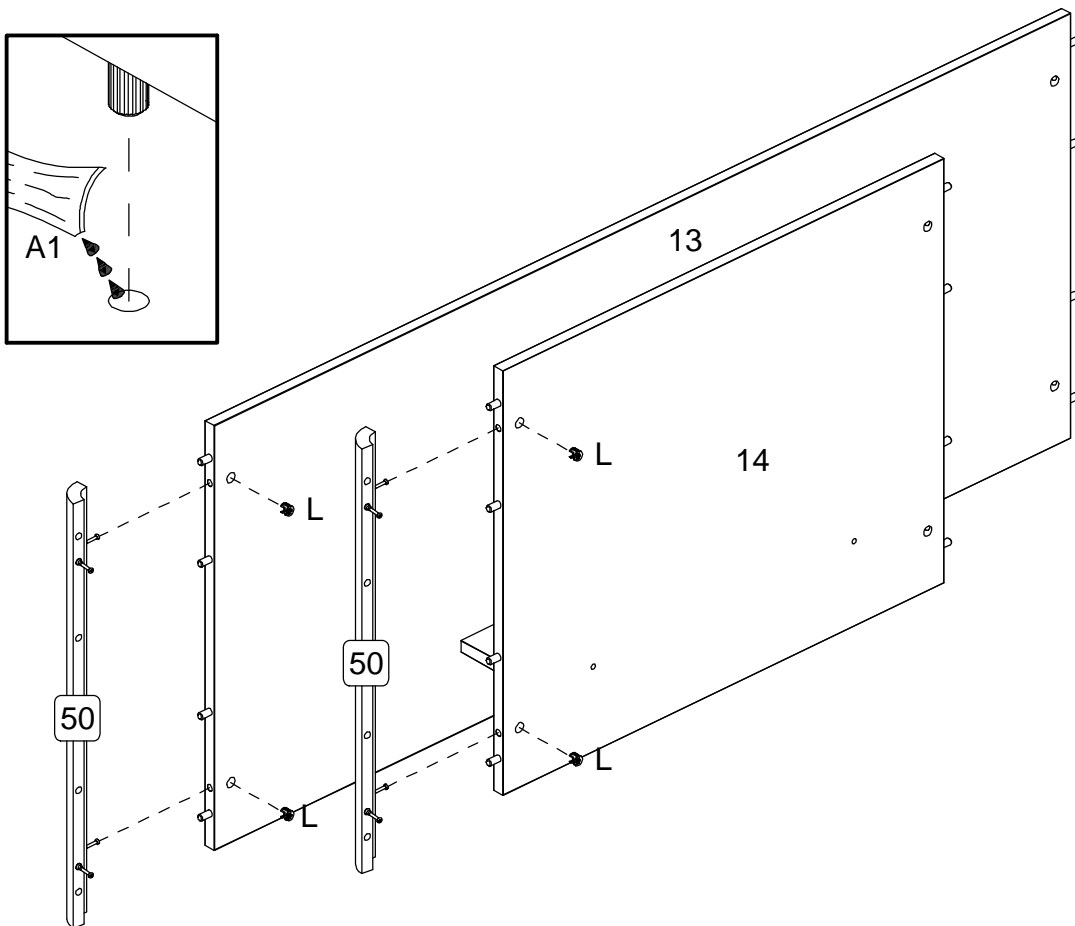

13

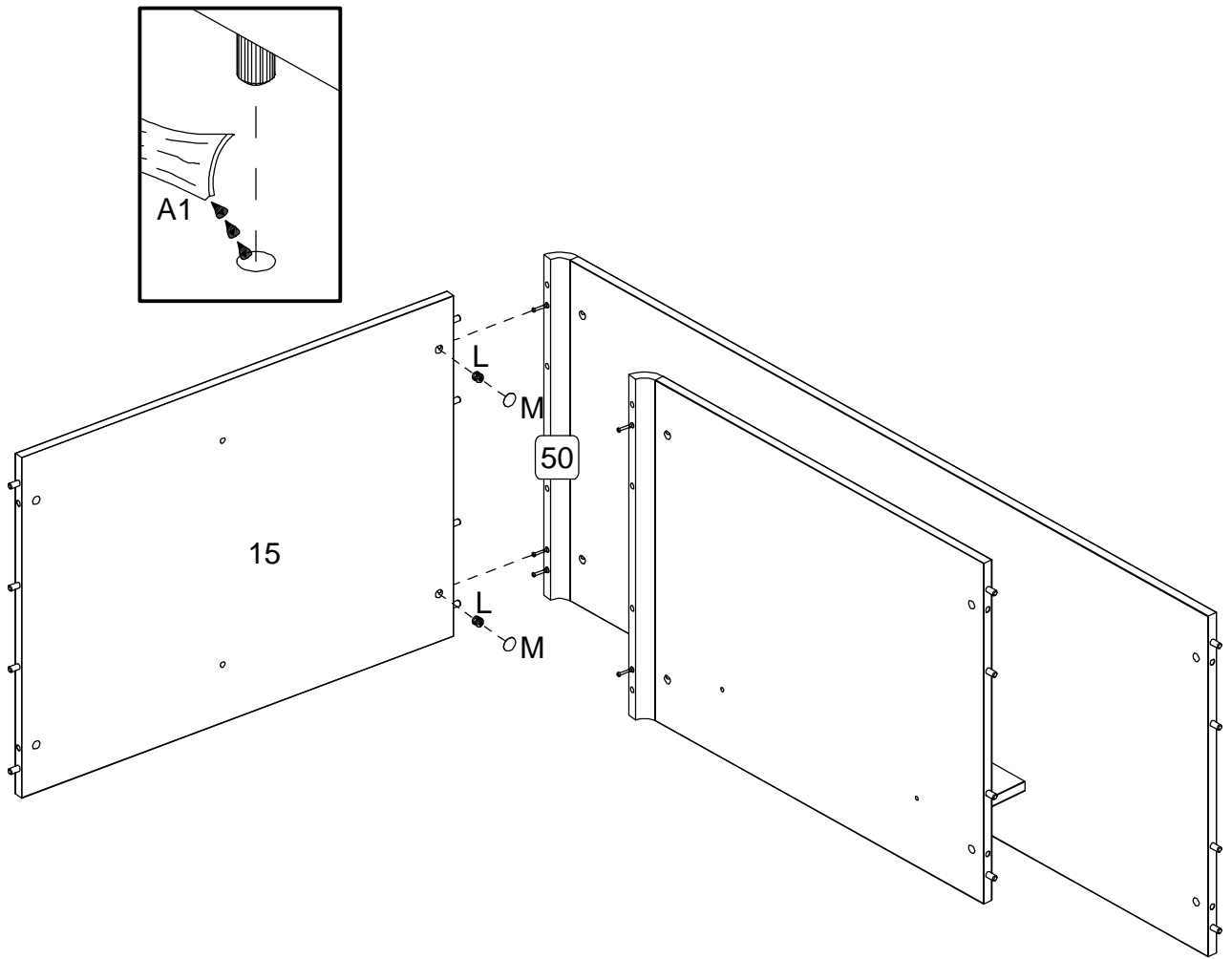

14

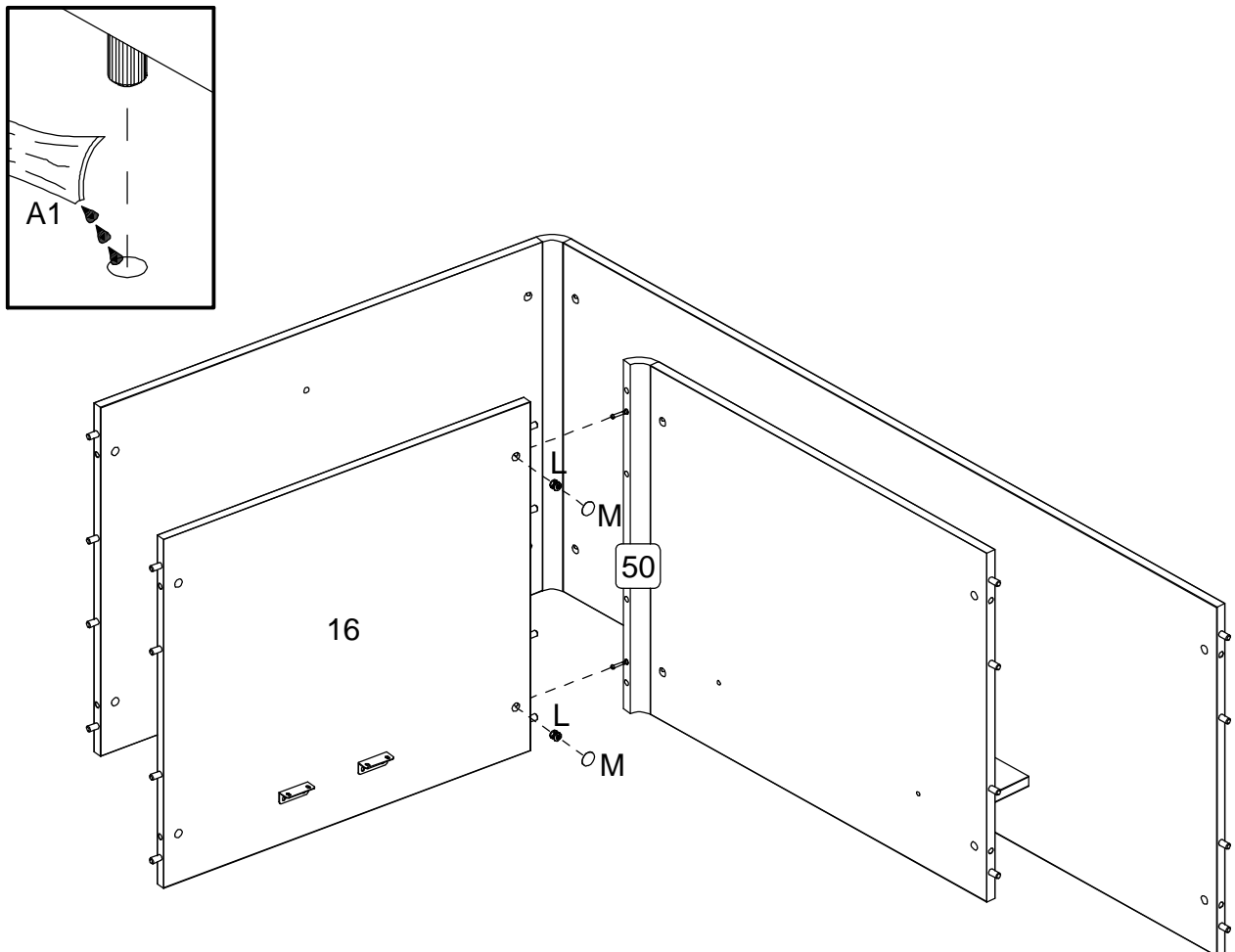

15

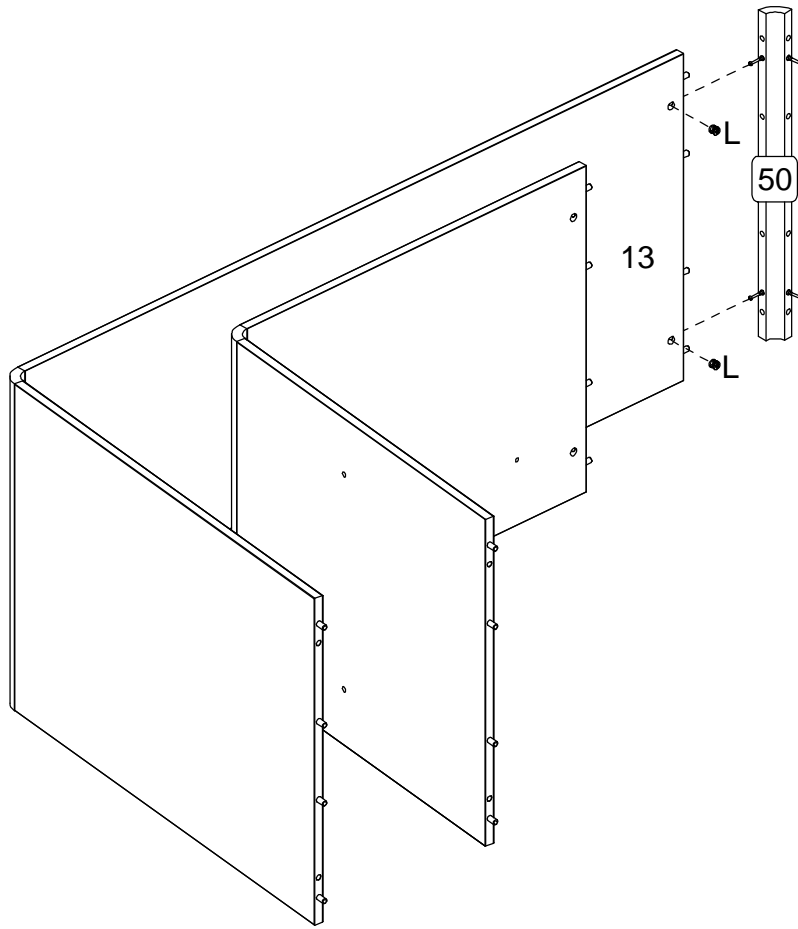
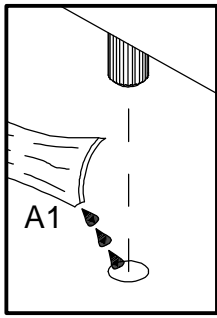

16

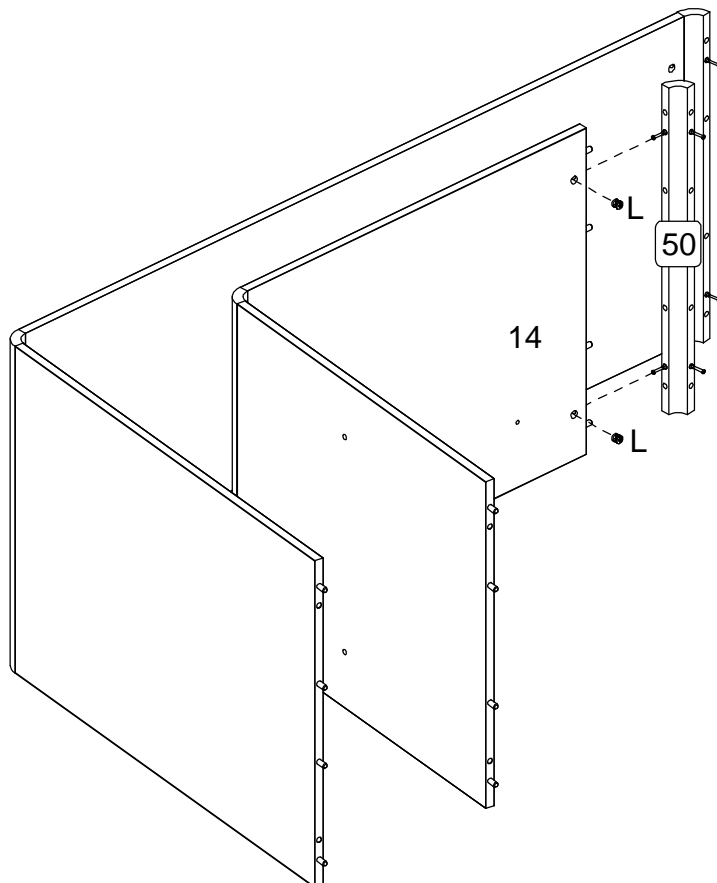
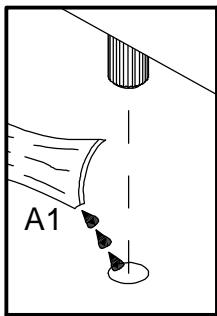

17

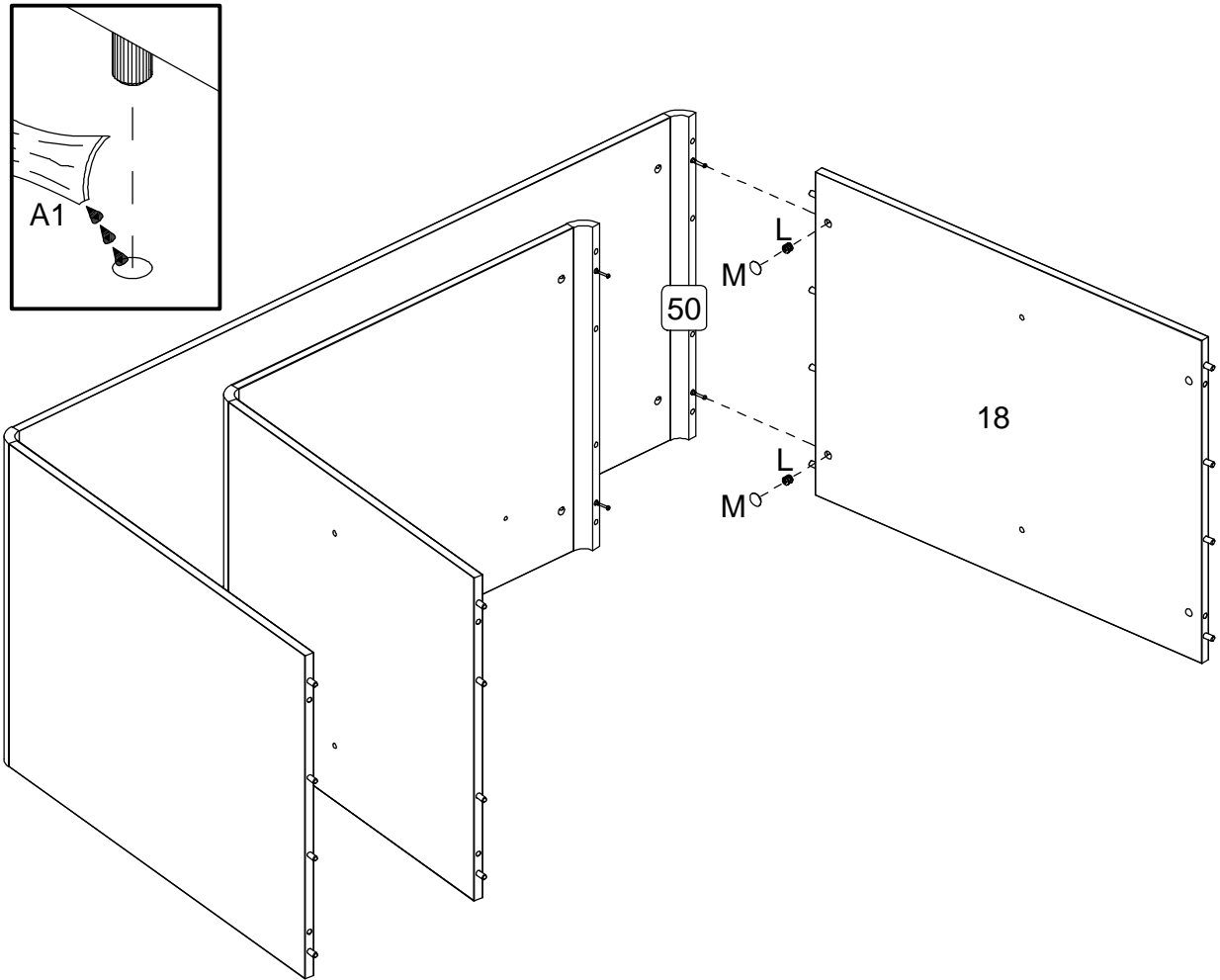

18

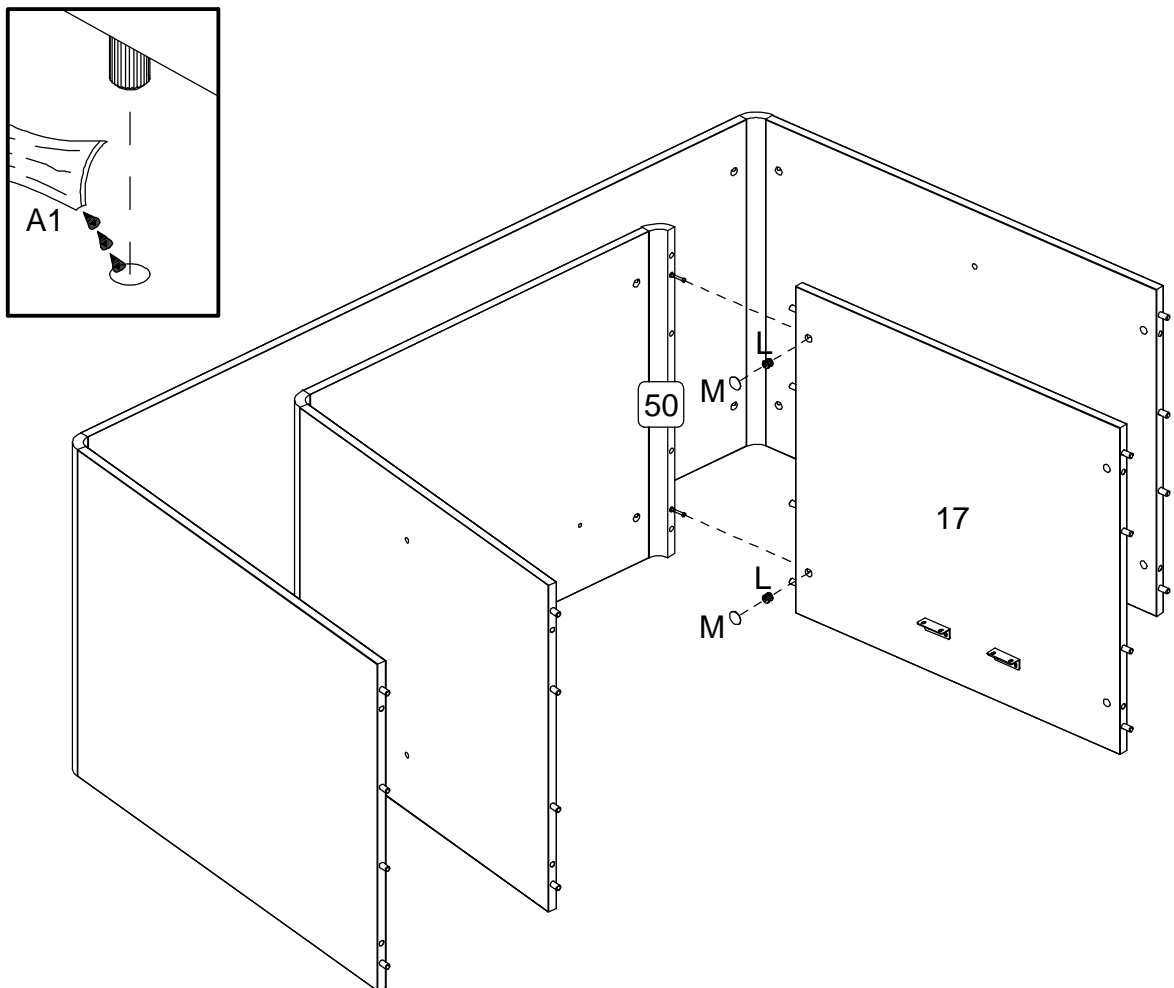

19

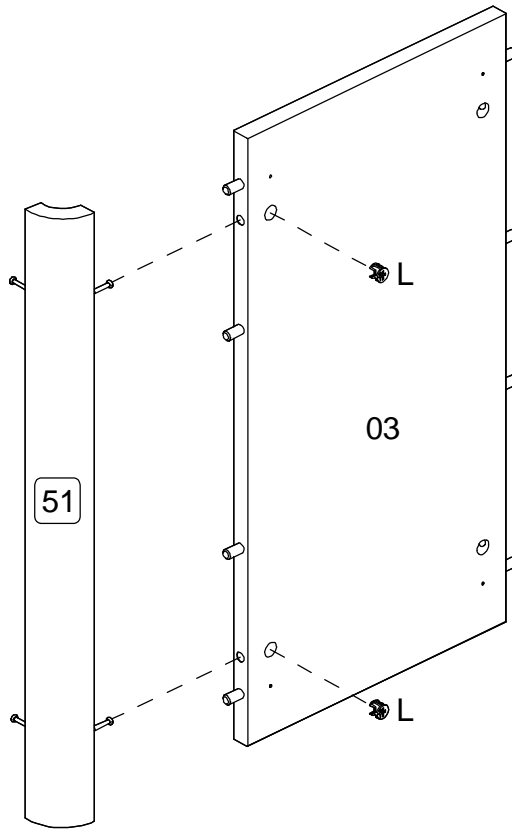
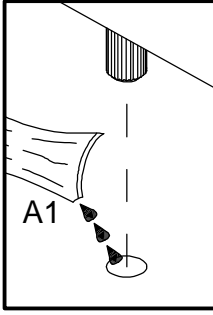

20

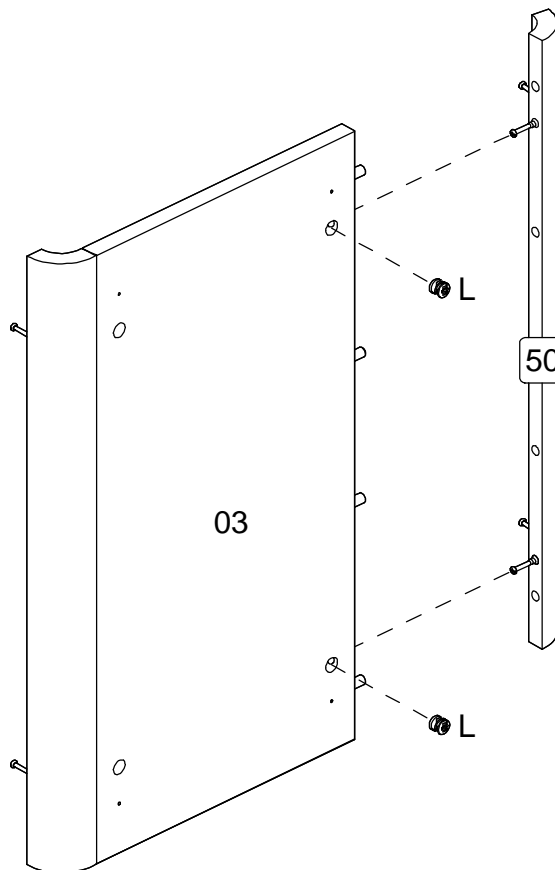
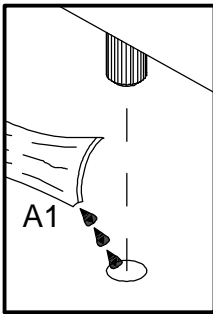

21

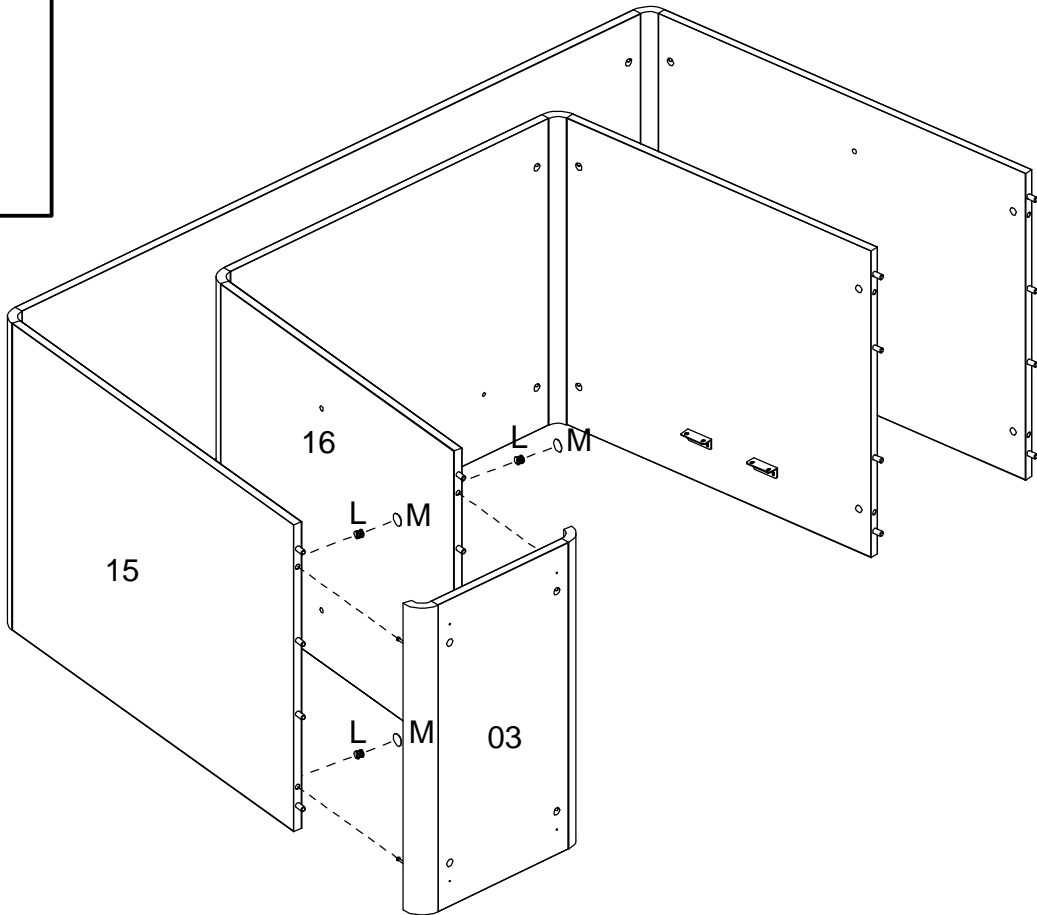
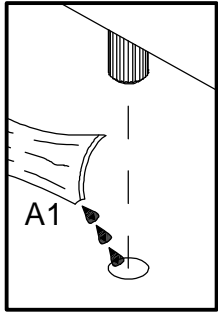

22

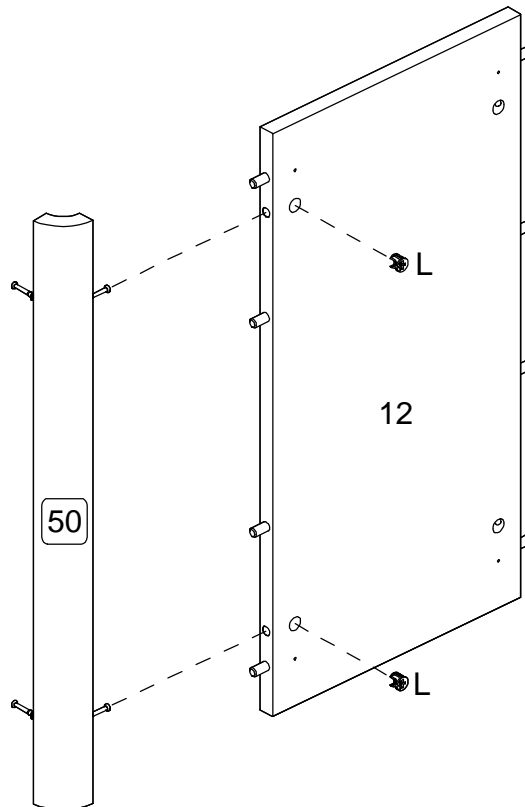
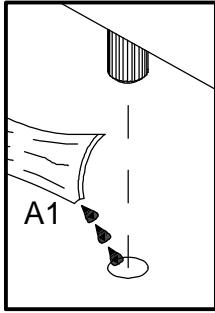

23

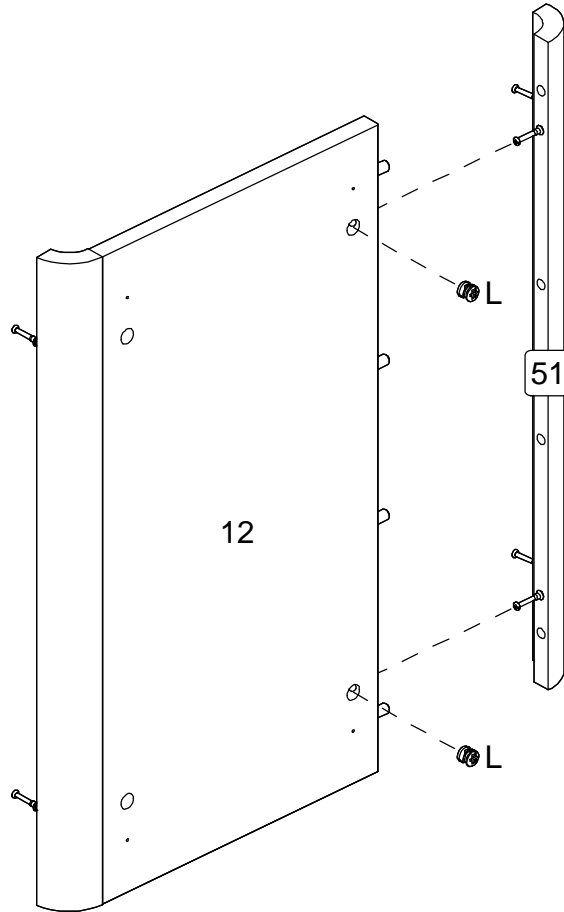
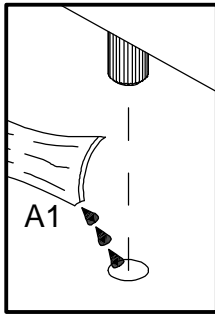

24

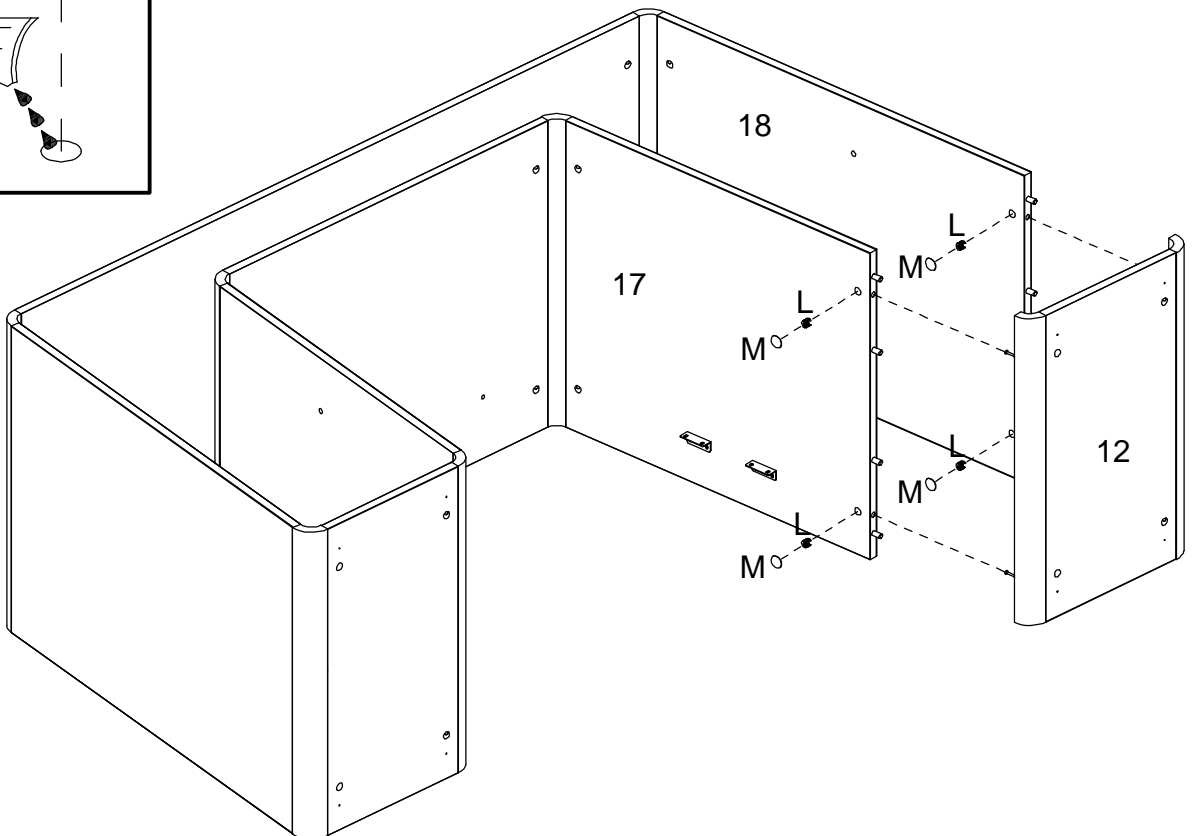
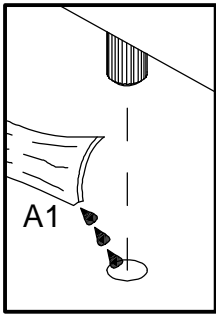

25

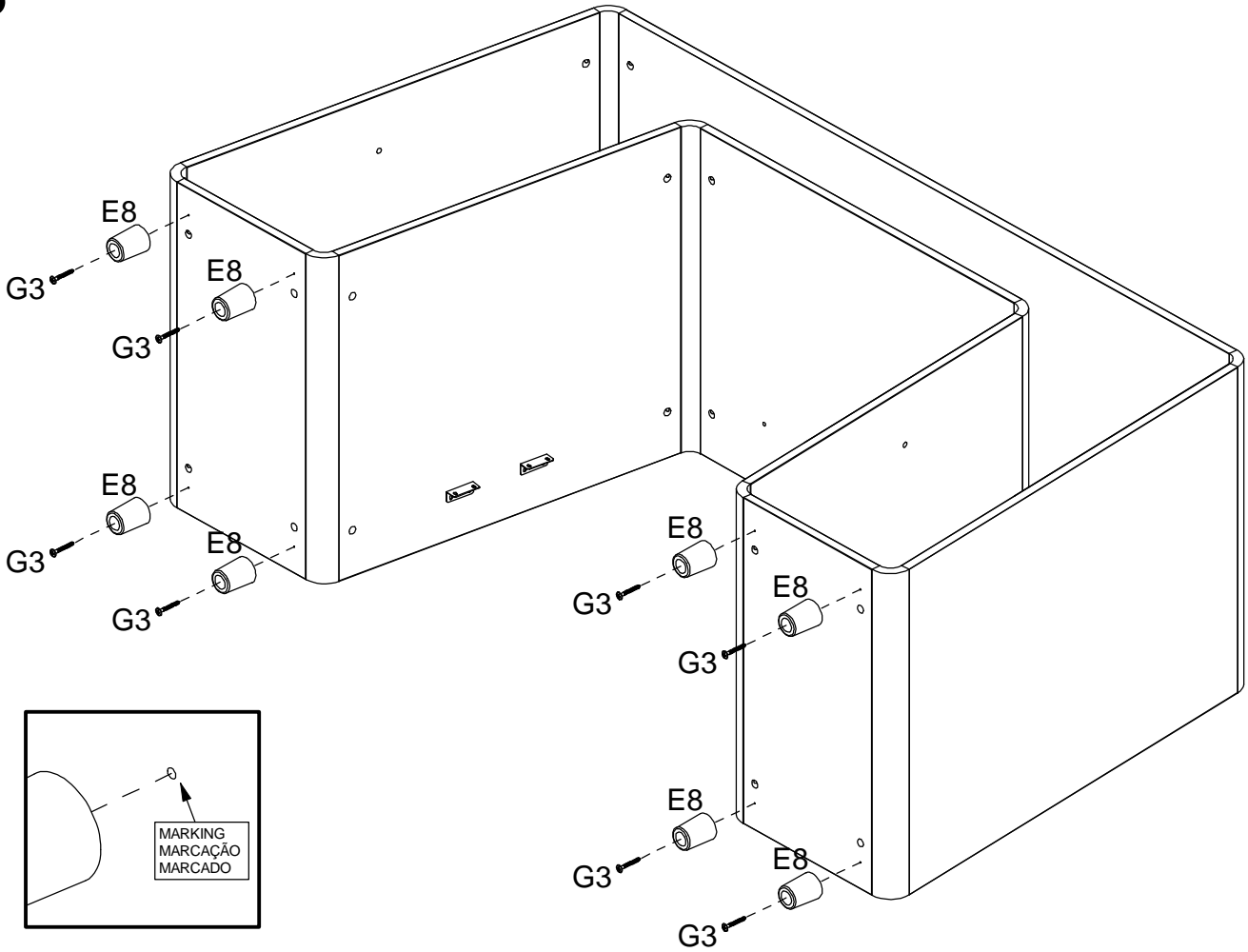

26

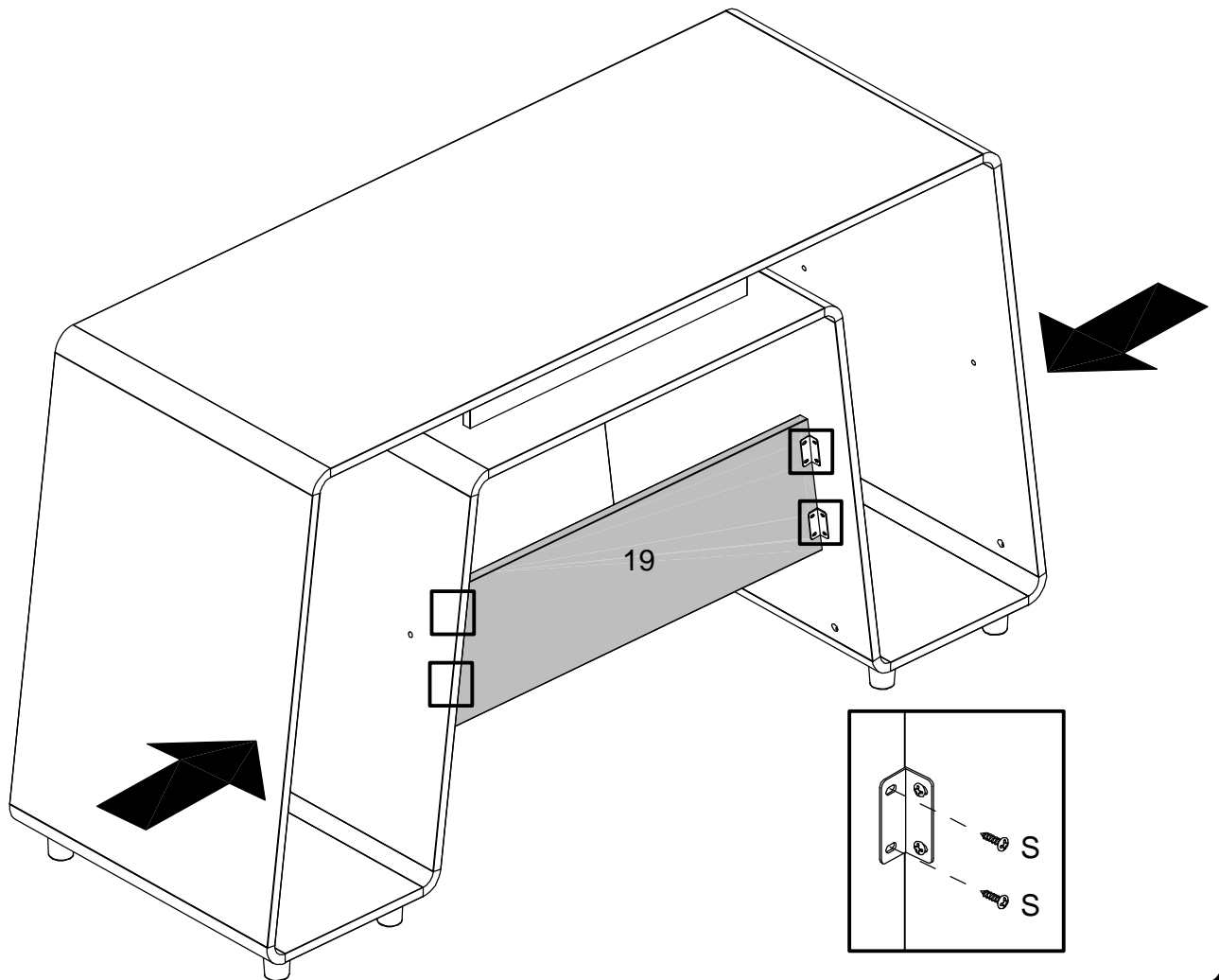

ASSEMBLING SHELF FOR THE RIGHT

MONTAGEM DA PRATELEIRA PARA A DIREITA / ARMADO DE LA REPISA PARA LA DERECHA.

27

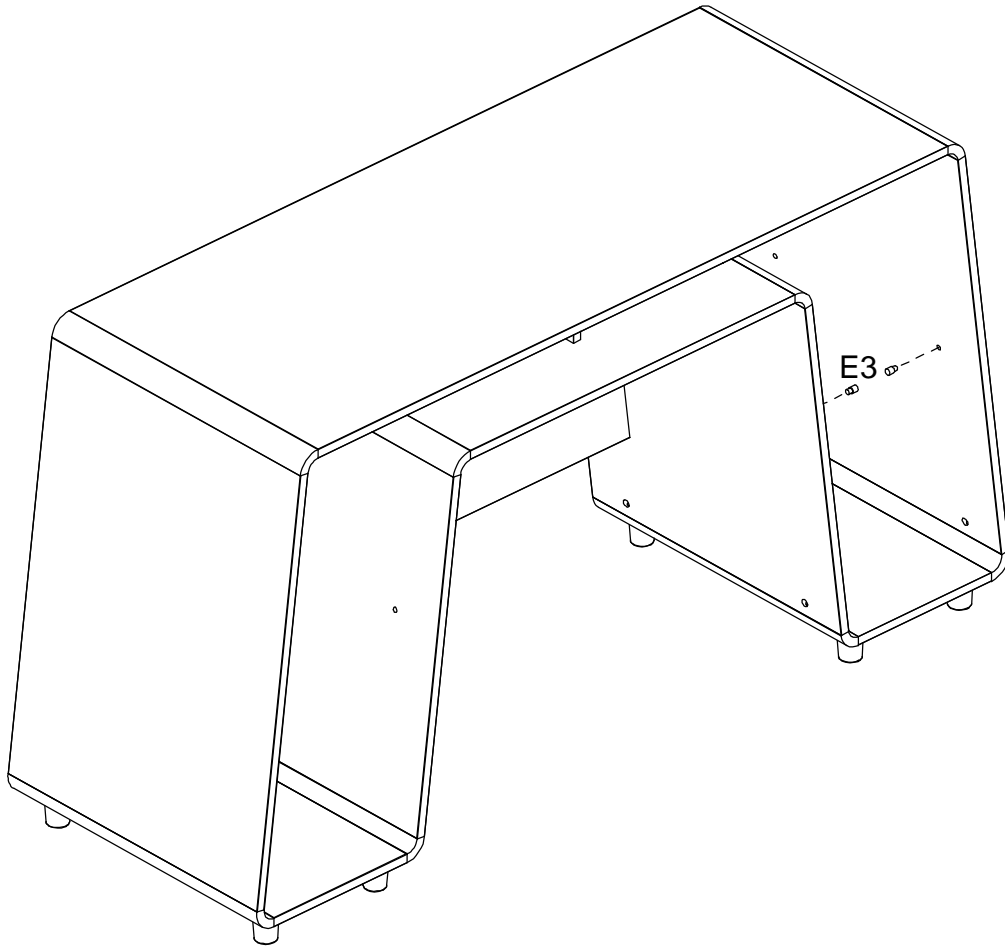

28

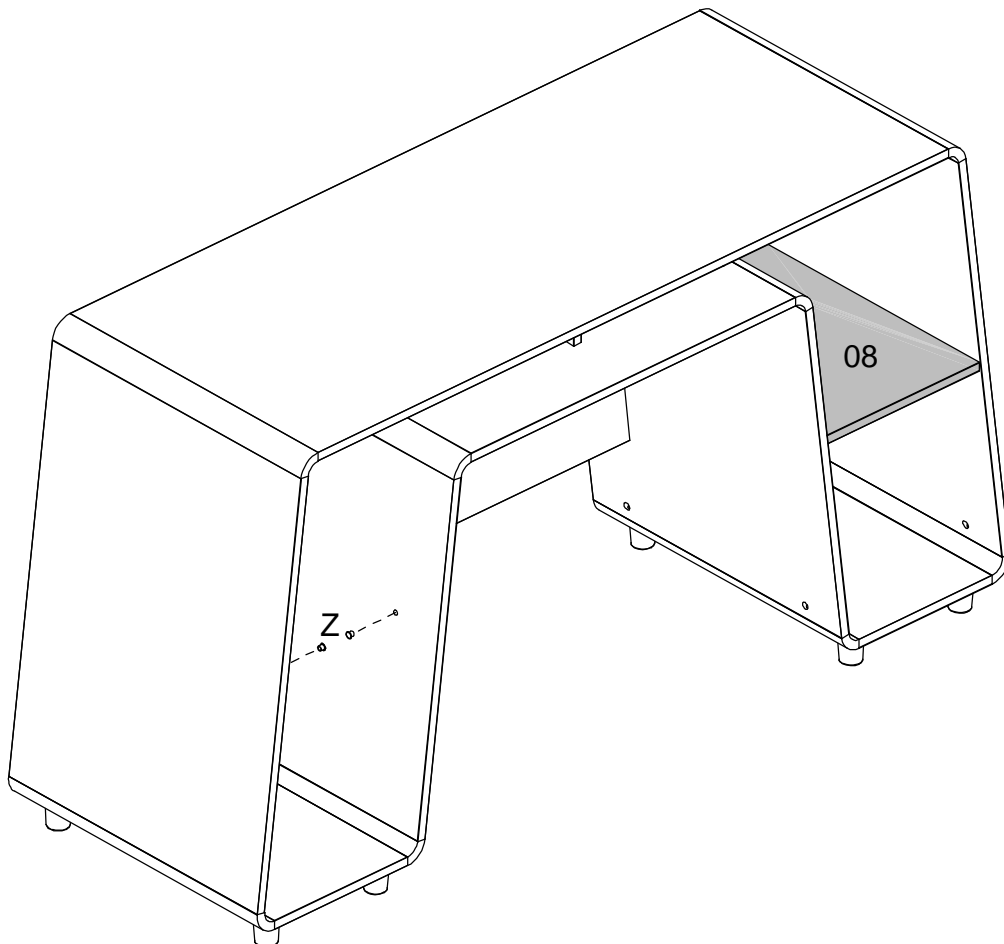

ASSEMBLING SHELF FOR THE LEFT
MONTAGEM DA PRATELEIRA PARA A ESQUERDA / ARMADO DE LA REPISA PARA LA IZQUIERDA.

29

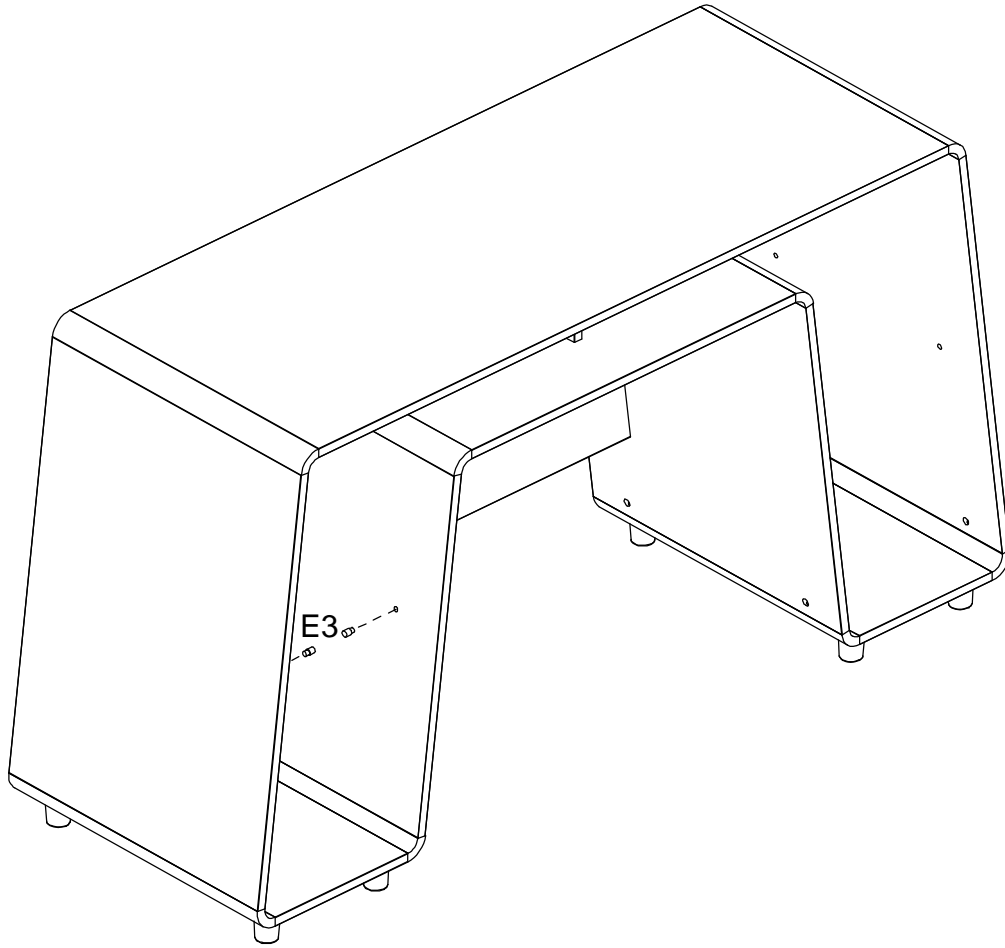

30

