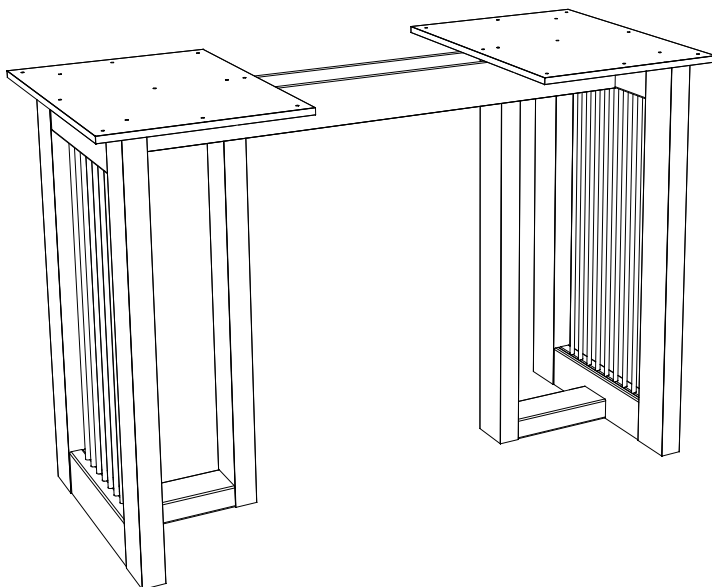
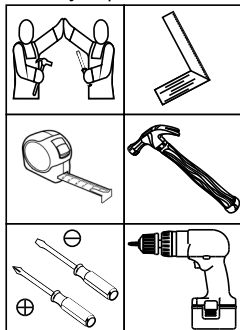

**HENN**Ind. e Com. de Móveis Henn  
Mondai - SC - Brasil

☎ +55 49 3674.3500

📧 @moveishenn  
www.henn.com.br**INSTRUÇÕES DE  
MONTAGEM**INSTRUCCIONES DE MONTAJE  
ASSEMBLY INSTRUCTIONS**BASE MESA YARA | BASE MESA YARA | YARA TABLE  
BASE**

S426-128 Nature

**Requisitos para montagem  
Requisitos para la montaje  
Assembly Requirements**

Imagens meramente ilustrativas,  
não acompanha o produto.  
Imágenes ilustrativas, no incluidas  
con el producto.

Illustrative images, not included  
with the product.

**AVISO**

Para limpeza de seu móvel, use uma franela seca ou umedecida, e não utilize produtos químicos que possam danificar seu produto.

**SISTEMA DE MONTAGEM**

O sistema de montagem dos produtos, funciona de acordo com a ordem crescente dos números indicados no desenho. Ex: 01, 02, 03, 04... até a conclusão da montagem.

**ASSISTÊNCIA TÉCNICA**

Para solicitação de Assistência Técnica você consumidor deverá entrar em contato com o Lojista a qual você realizou a compra deste produto e solicitar a assistência técnica das peças avariadas. A garantia abrange todas as peças, partes e componentes que eventualmente venham apresentar defeito de fabricação no prazo de 03 (três) meses, contando a partir da entrega do produto ao consumidor, mediante nota fiscal de compra. Se houver qualquer alteração na estrutura do produto ou ocorrer defeito por negligência do montador/consumidor em relação a instrução de montagem e manuseio, não será fornecido assistência técnica gratuita.

**ADVERTENCIA**

Para limpieza de su móvil, use una franela seca o húmeda, y no utilice productos químicos que puedan dañar su producto.

**SISTEMA DE MONTAJE**

El sistema de montaje de los productos funciona de acuerdo con el orden creciente de los números indicados en el dibujo. Ej.: 01, 02, 03, 04... hasta la conclusión del montaje.

**ASISTENCIA TÉCNICA**

Para solicitar Asistencia Técnica, el consumidor debe comunicarse con el Comercio que usted realizó la compra de este producto y solicita asistencia técnica para las partes dañadas. La garantía cubre todas las partes, piezas y componentes que eventualmente puedan presentar defecto de fabricación en el plazo de 03 (tres) meses, contados a partir de la entrega del producto al consumidor, mediante factura de compra. Si se produce algún cambio en la estructura del producto o se produce un defecto por negligencia del montador/consumidor en relación con las instrucciones de montaje y manipulación, no se prestará asistencia técnica gratuita.

**NOTICE**

To clean your furniture, use a dry or wet cloth, and do not use chemicals that may damage your product.

**ASSEMBLY SYSTEM**

The products' assembly system works according to the increasing order of the indicated numbers. For example: 01, 02, 03, 04 ... to the end of the assembly.

**TECHNICAL ASSISTANCE**

To request Technical Assistance, the consumer must contact the retailer from whom you purchased this product and request technical assistance for the damaged parts. The warranty covers all parts, parts and components that may eventually present a manufacturing defect within a period of 03 (three) months, counting from the delivery of the product to the consumer, by means of a purchase invoice. If there is any change in the structure of the product or defect occurs due to negligence of the assembler/consumer in relation to the assembly and handling instruction, free technical assistance will not be provided.

## ACESSÓRIOS | ACCESORIOS | ACCESSORIES

A

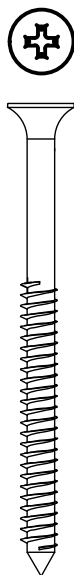
**x16**

B

**x6**

C

**x46**

D

**x30**

E

**x16**

F

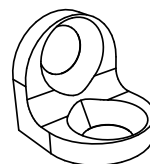
**x4**

Parafusos em escala  
Tornillos escalados  
Scaled screws

**1:1**

## ACESSÓRIOS | ACCESORIOS | ACCESSORIES

G

**x8**

H

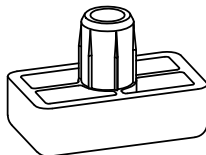
**x6**

I

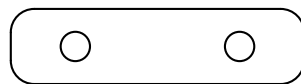
**x4**

J

**x2**

K

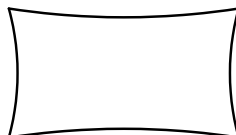
**x1**

L

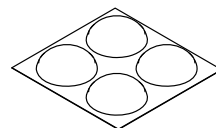
**x8**

M

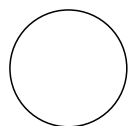
**x28**

N

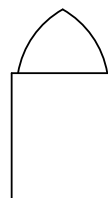
**x1**

## LISTA DE PEÇAS | LISTA DE PIEZAS | LIST OF PIECES

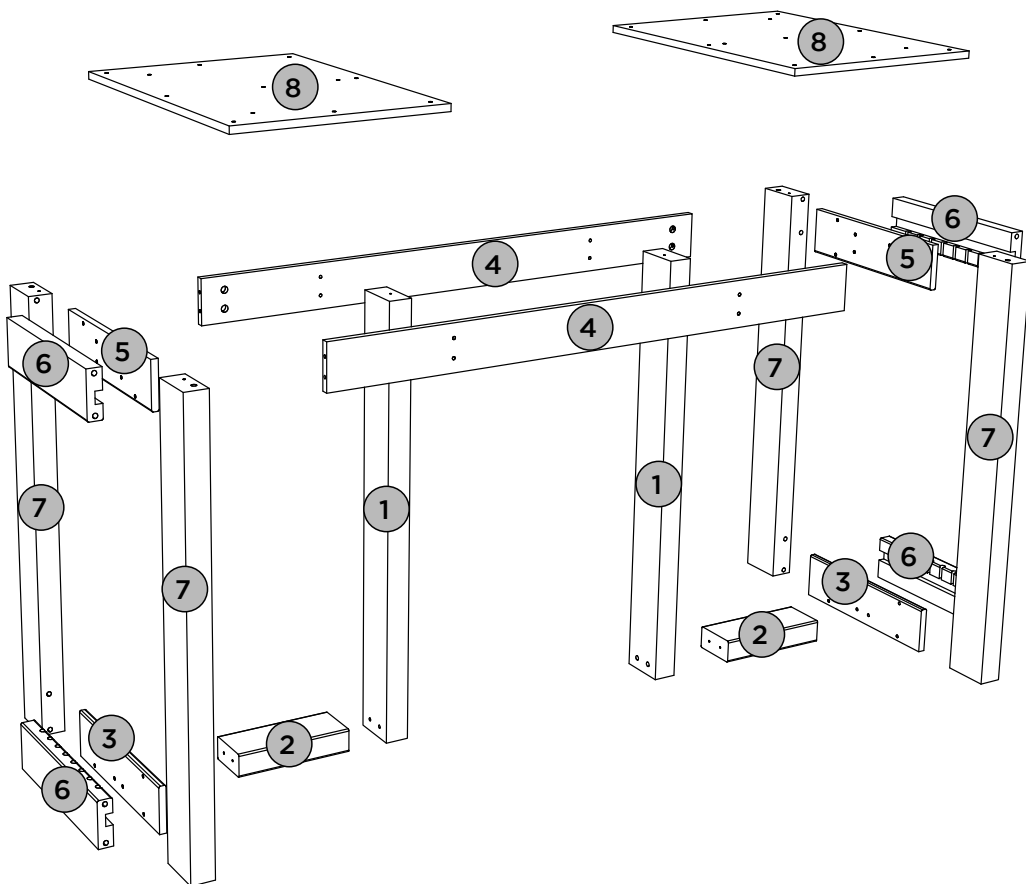





Item	Caixa Caja Box	Qtd Ctd Qty	Descrição Descripción Description	Dimensões (mm)   Dimensiones (mm)		
				Comprimento Largo Length	Largura Ancho Width	Espessura Grosor Thickness
1	1/1	02	TRAVESSA ESTRUTURAL   TRAVESAÑO ESTRUCTURAL   CROSSBAR STRUCTURAL	754	80	40
2	1/1	02	TRAVESSA   TRAVESAÑO   CROSSBAR	200	78	40
3	1/1	02	TRAVESSA INFERIOR MENOR   BANDEJA INFERIOR PEQUEÑA   LOWER TRAY SMALLER	309	80	12
4	1/1	02	TRAVESSA SUSTENTAÇÃO   BANDEJA DE SOPORTE   SUPPORT TRAY	980	80	12
5	1/1	02	TRAVESSA SUPERIOR MENOR   BANDEJA SUPERIOR PEQUEÑA   SMALLER UPPER TRAY	309	80	12
6	1/1	04	TRAVESSA SUPERIOR INFERIOR   BANDEJA INFERIOR SUPERIOR   UPPER BOTTOM TRAY	310	80	25
7	1/1	04	MOLDURA LATERAL   MARCO LATERAL   SIDE FRAME	754	80	40
8	1/1	02	TAMPO ESTRUTURAL   PARTE SUPERIOR ESTRUCTURAL   STRUCTURAL TOP	500	360	12

**PEÇAS REQUERIDAS**

1	TRAVESSA ESTRUTURAL	x2
4	TRAVESSA SUSTENTAÇÃO	x2
6	TRAVESSA SUPERIOR INFERIOR	x4
7	MOLDURA LATERAL	x4

**ACESSÓRIOS REQUERIDOS**

E		16
G		08
H		06
K		01

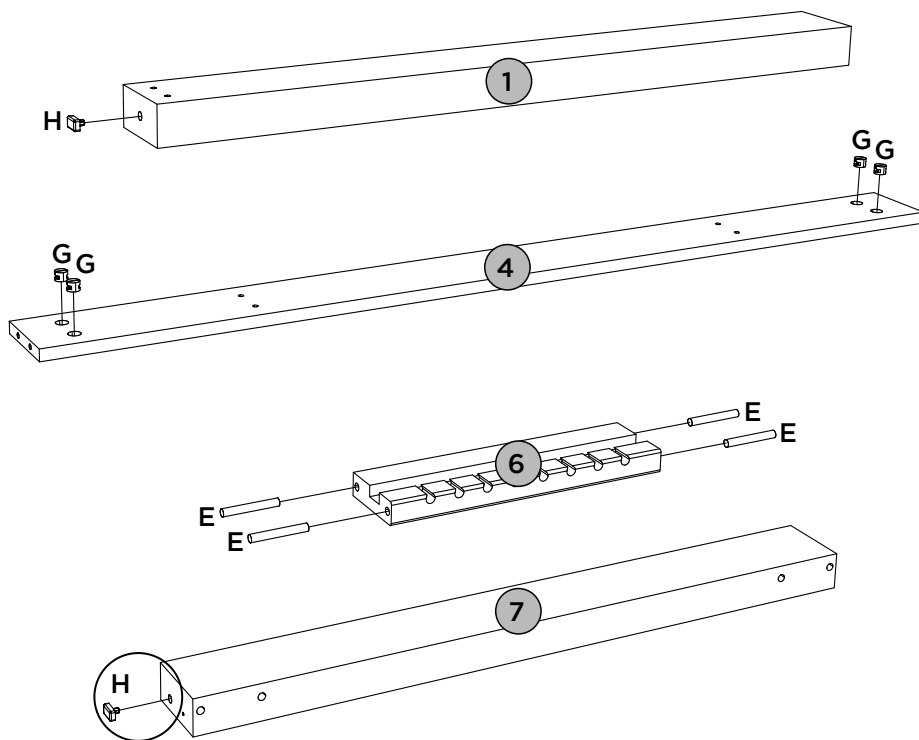
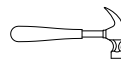
**FERRAMENTAS NECESSÁRIAS**

Colocar cola na  
fixação da sapata.

Ponga pegamen-  
to en la fijación  
del zapato.

Put glue on the  
shoe fixing.

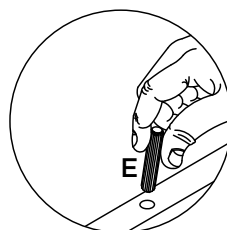

# PASSO 2

ITM/S426-

## PEÇAS REQUERIDAS

1	TRAVESSA ESTRUTURAL	x2
2	TRAVESSA	x2
3	TRAVESSA INFERIOR MENOR	x2

## ACESSÓRIOS REQUERIDOS

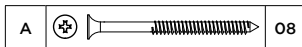

## FERRAMENTAS NECESSÁRIAS

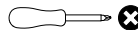

**2x**

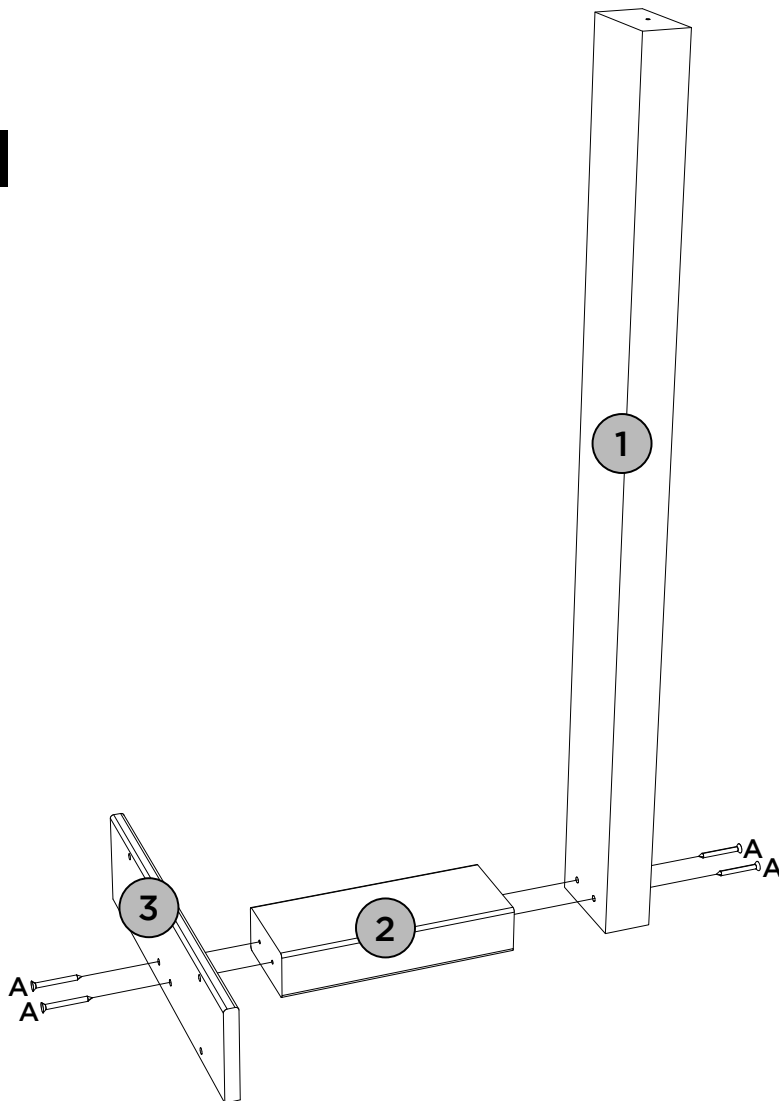



# PASSO 3

ITM/S426-

## PEÇAS REQUERIDAS

4	TRAVESSA SUSTENTAÇÃO	x2
5	TRAVESSA SUPERIOR MENOR	X2

## ACESSÓRIOS REQUERIDOS

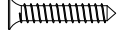
A			08
C			08

## FERRAMENTAS NECESSÁRIAS

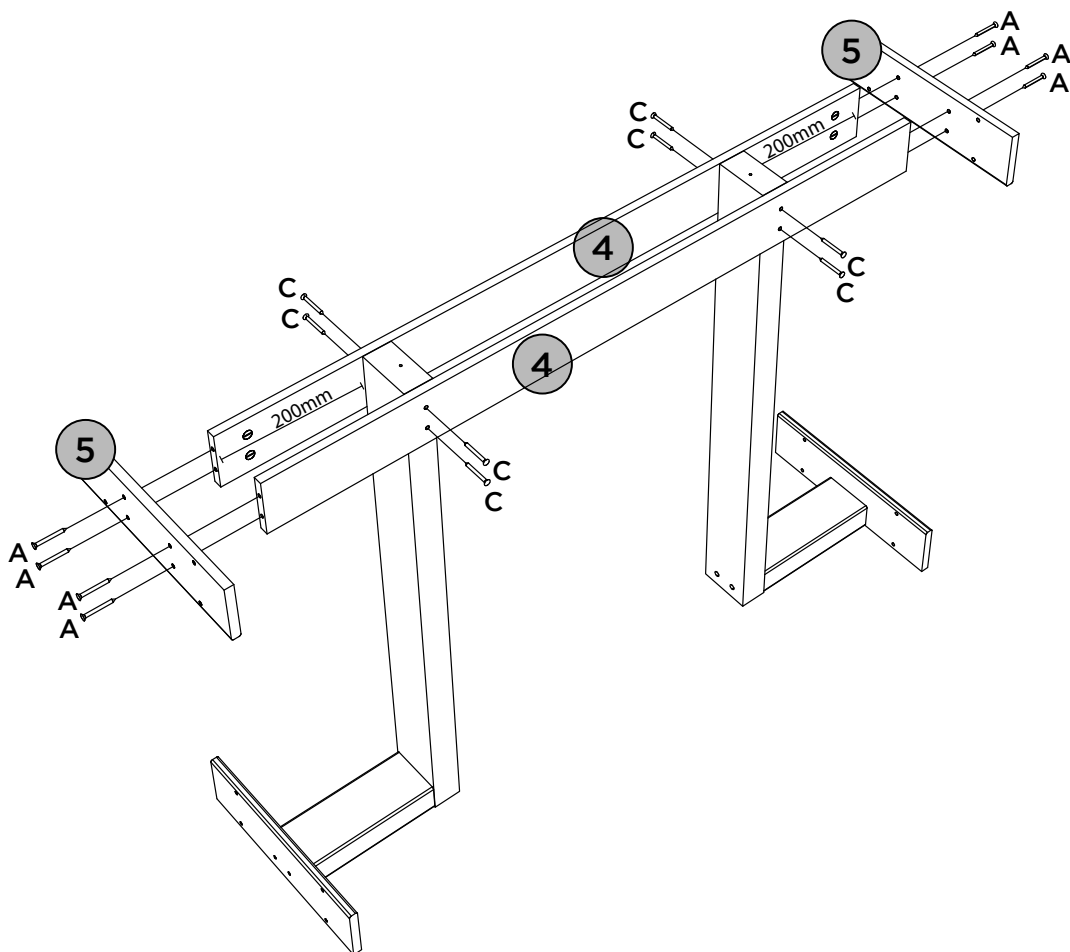
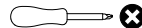





# PASSO 5

ITM/S426-

## PEÇAS REQUERIDAS

6	TRAVESSA SUPERIOR INFERIOR	x4
7	MOLDURA LATERAL	x4

## ACESSÓRIOS REQUERIDOS

C		04
D		26
F		04
I		04
J		02

## FERRAMENTAS NECESSÁRIAS



2x

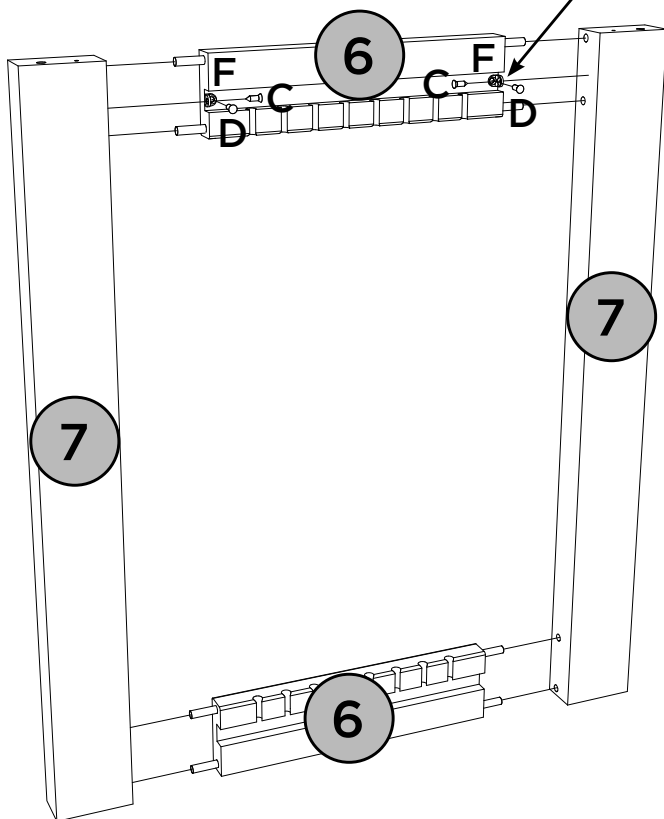
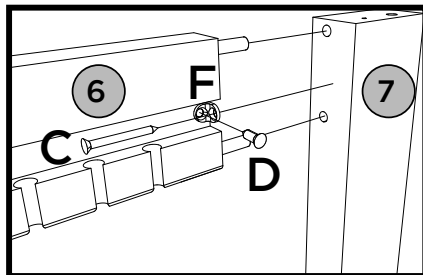







**PASSO 5****PEÇAS REQUERIDAS**

6	TRAVESSA SUPERIOR INFERIOR	x4
7	MOLDURA LATERAL	x4

**ACESSÓRIOS REQUERIDOS**

C		04
D		26
F		04
I		04
J		02

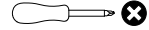
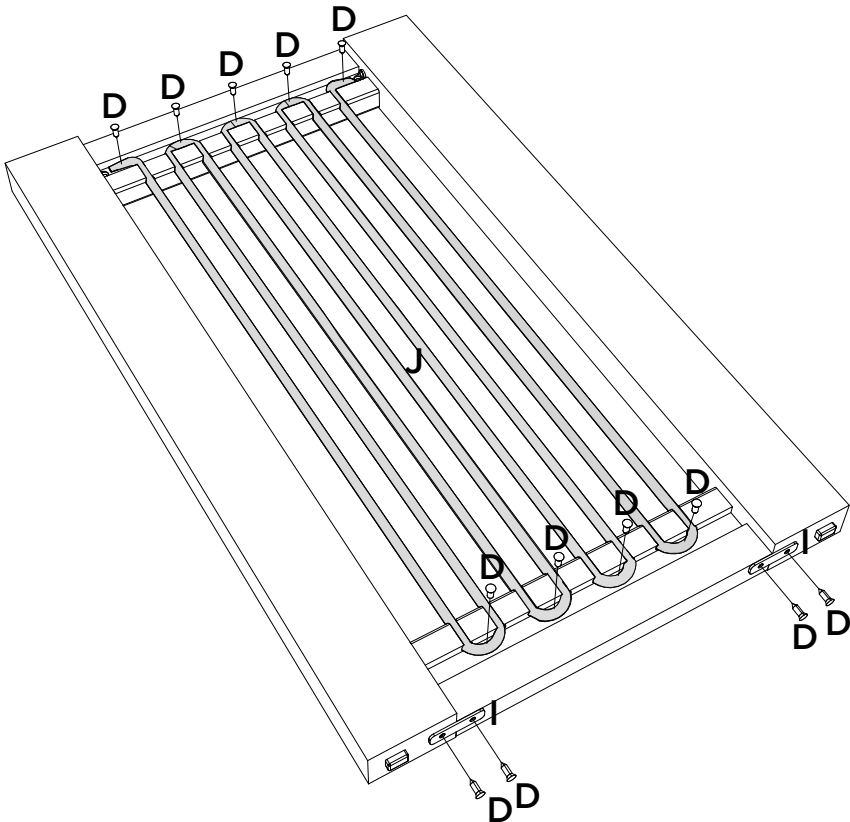
**FERRAMENTAS NECESSÁRIAS****2x**

ACESSÓRIOS REQUERIDOS

FERRAMENTAS NECESSÁRIAS

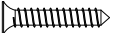
C			16
---	---	---	----

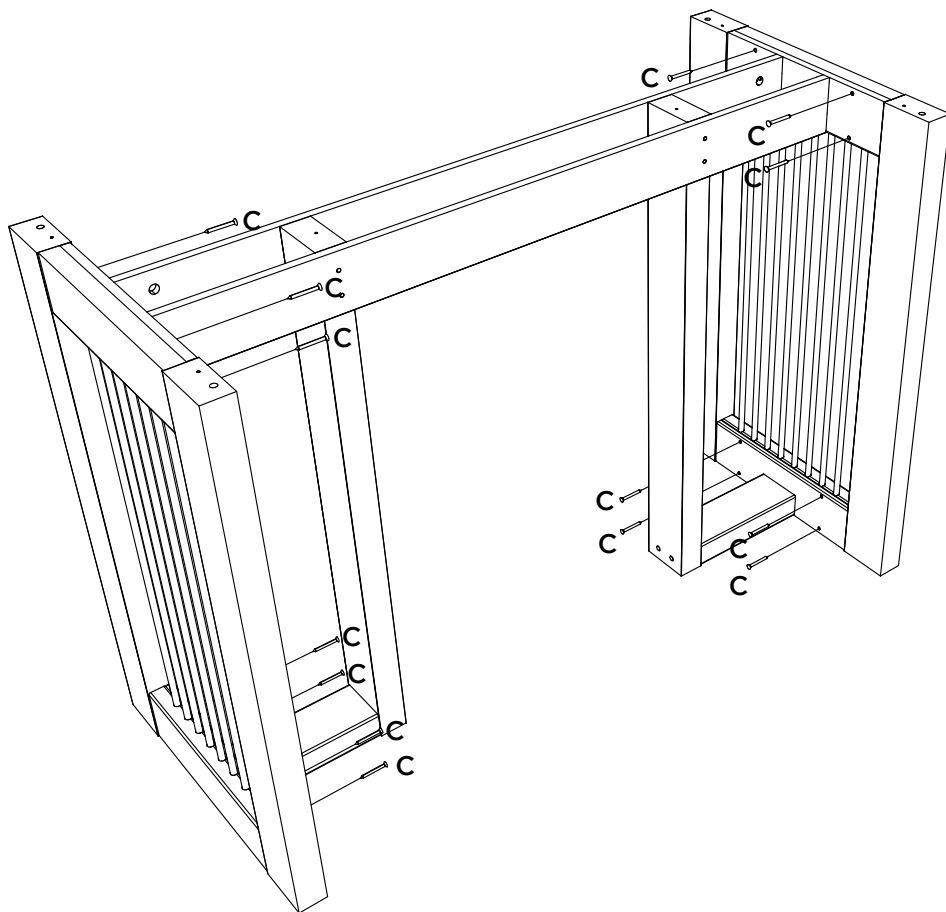
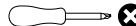

# PASSO 7

ITM/S426-

## PEÇAS REQUERIDAS

## ACESSÓRIOS REQUERIDOS

## FERRAMENTAS NECESSÁRIAS

8	TAMPO ESTRUTURAL	x2
---	------------------	----

B		06
---	---	----

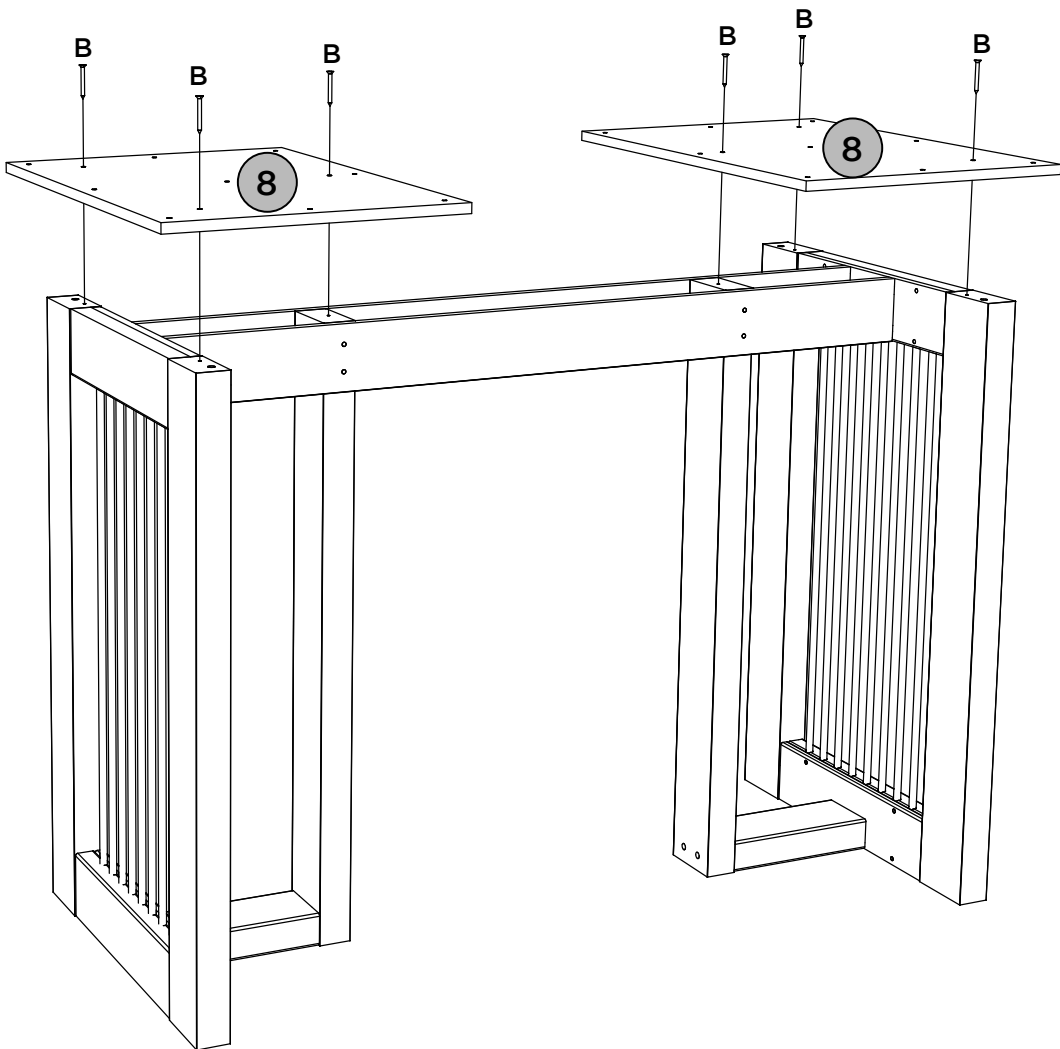
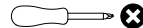

Opção de Montagem com o Tampo 2000x900  
canto reto com Vidro (S906-139)

Opción de montaje con parte superior 2000x900  
esquina recta con vidrio (S906-139)

Mounting Option with Top 2000x900  
straight corner with Glass (S906-139)

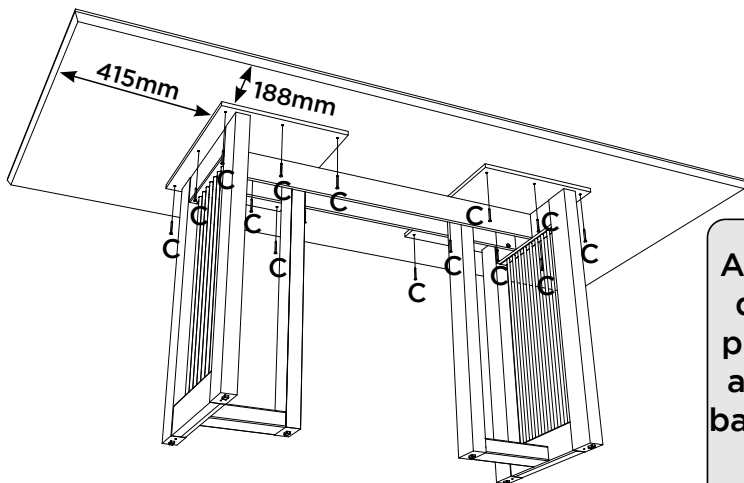

A pintura do Vidro  
deve ficar virada  
para baixo, depois  
ajustá-lo sobre os  
batentes de silicone  
(L)

La pintura de vidrio  
debe mirar ha-  
cia abajo, luego  
ajustarla sobre los  
topes de silicona  
(L)

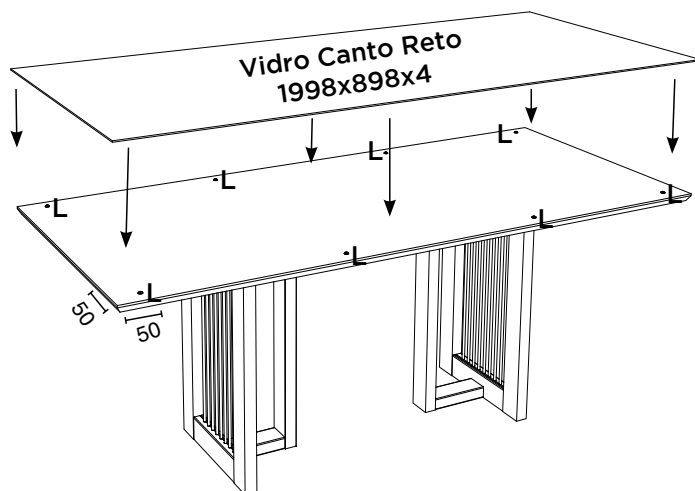

The glass paint  
should be facing  
downwards, then  
adjust it over the  
silicone stops (L)

Produto Concluído (S426 + S906)  
 Producto Terminado (S426 + S906)  
 Finished Product (S426 + S906)

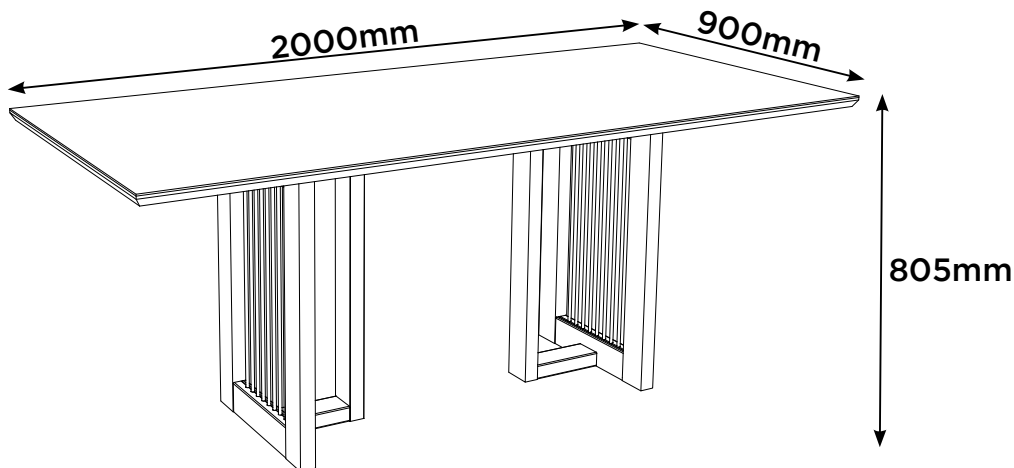

Opção de Montagem com o Tampo 2000x900  
 canto moeda com Vidro (S907-139)

Opción de montaje con parte superior 2000x900  
 Esquina de monedas con vidrio (S907-139)

Mounting Option with Top 2000x900  
 Coin corner with Glass (S907-139)

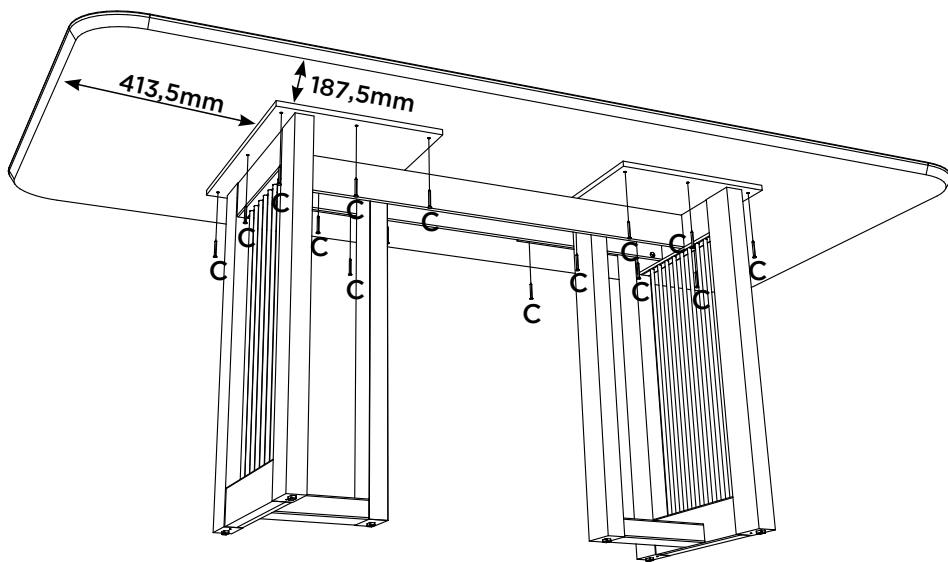

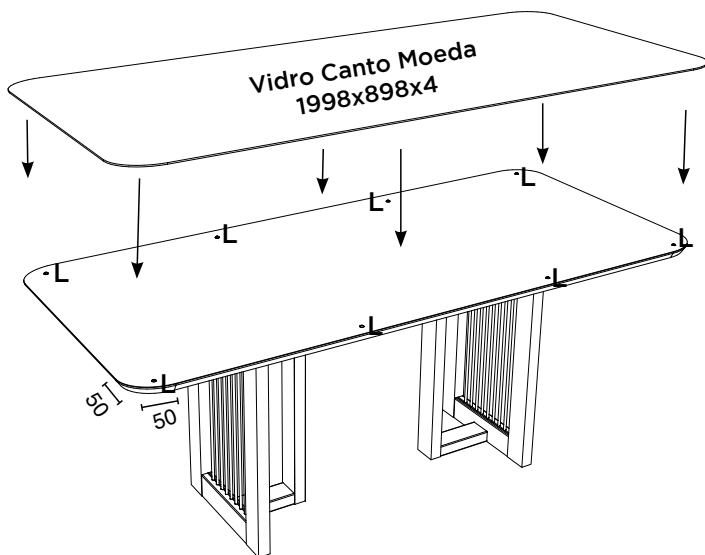

A pintura do Vidro deve ficar virada para baixo, depois ajustá-lo sobre os batentes de silicone (L)

La pintura de vidrio debe mirar hacia abajo, luego ajustarla sobre los topes de silicona (L)

The glass paint should be facing downwards, then adjust it over the silicone stops (L)

Produto Concluído (S426 + S907)  
Producto Terminado (S426 + S907)  
Finished Product (S426 + S907)

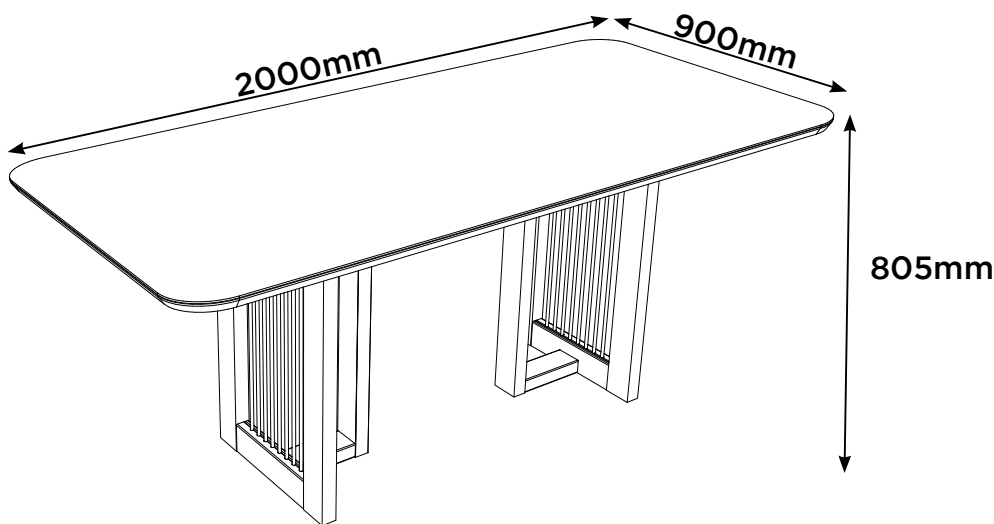

Opção de Montagem com o Tampo 1600x900  
canto reto com Vidro (S908-139)

Opción de montaje con parte superior 1600x900  
esquina recta con vidrio (S908-139)

Mounting Option with Top 1600x900  
straight corner with Glass (S908-139)

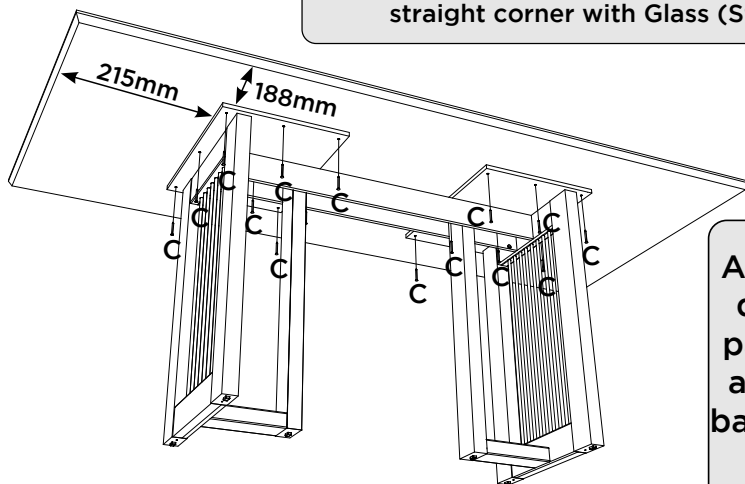

A pintura do Vidro  
deve ficar virada  
para baixo, depois  
ajustá-lo sobre os  
batentes de silicone  
(L)

La pintura de vidrio  
debe mirar ha-  
cia abajo, luego  
ajustarla sobre los  
topes de silicona  
(L)

The glass paint  
should be facing  
downwards, then  
adjust it over the  
silicone stops (L)

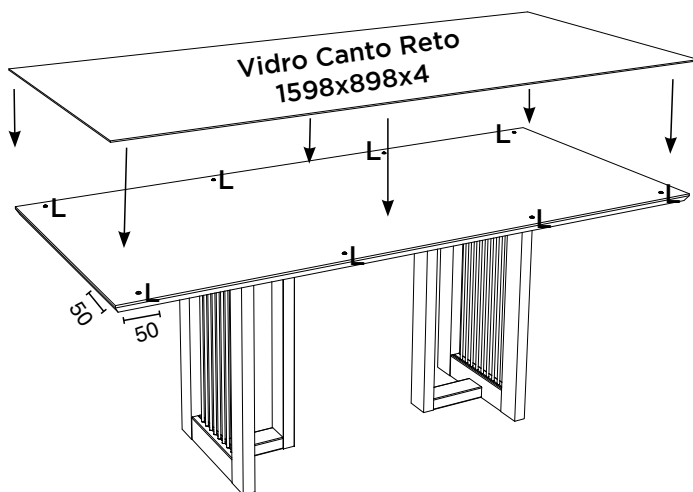

Produto Concluído (S426 + S908)  
 Producto Terminado (S426 + S908)  
 Finished Product (S426 + S908)

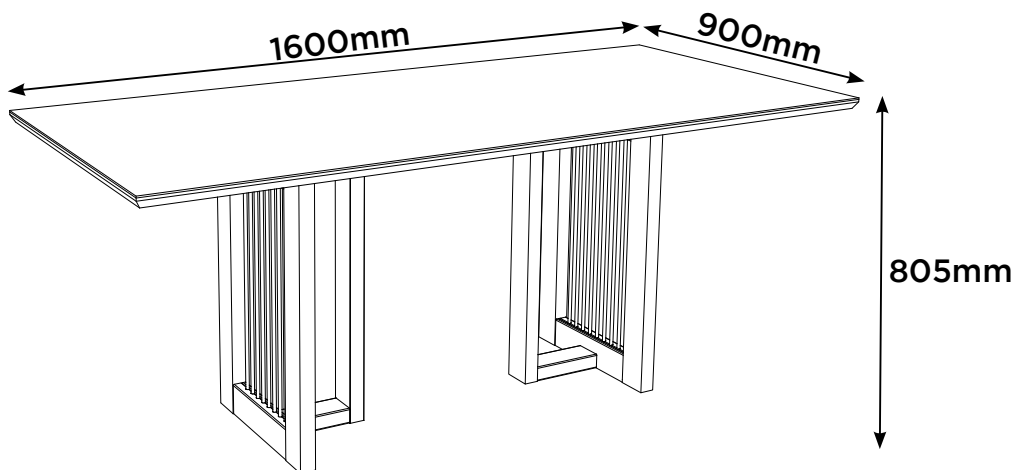

Opção de Montagem com o Tampo 1600x900  
 canto moeda com Vidro (S909-139)

Opción de montaje con parte superior 1600x900  
 Esquina de monedas con vidrio (S909-139)

Mounting Option with Top 1600x900  
 Coin corner with Glass (S909-139)

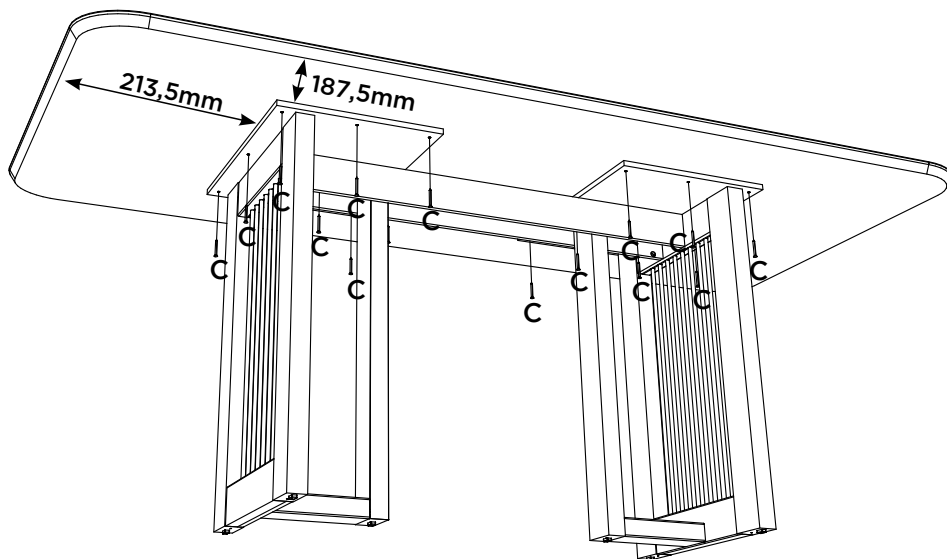



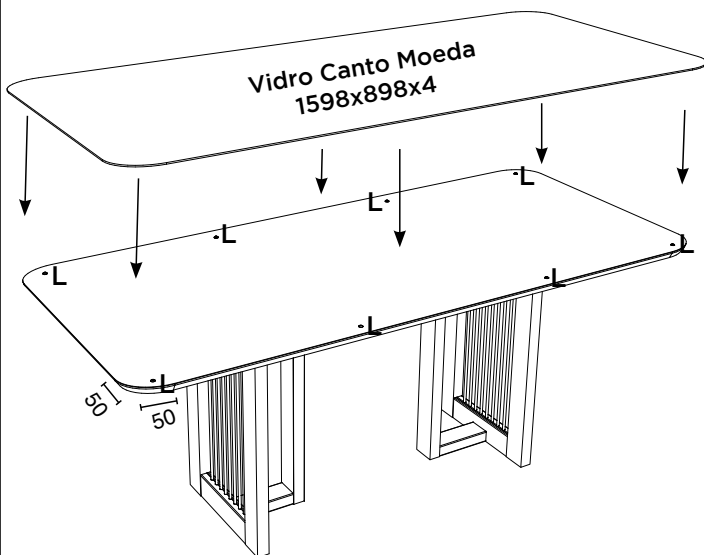

A pintura do Vidro deve ficar virada para baixo, depois ajustá-lo sobre os batentes de silicone (L)

La pintura de vidrio debe mirar hacia abajo, luego ajustarla sobre los toques de silicona (L)

The glass paint should be facing downwards, then adjust it over the silicone stops (L)

Produto Concluído (S426 + S909)  
Producto Terminado (S426 + S909)  
Finished Product (S426 + S909)

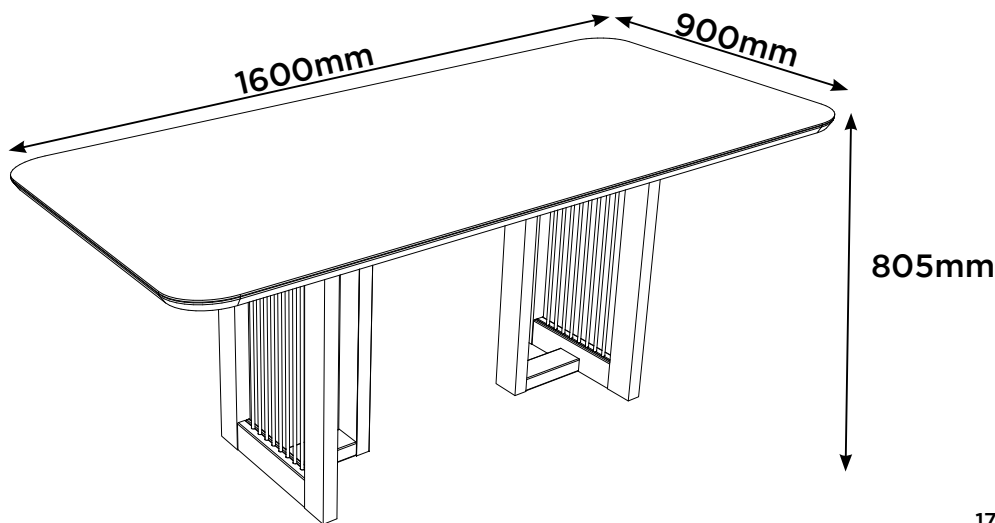

**Opção de Montagem com o Tampo 1600x900  
canto reto sem Vidro (S910-139)**

**Opción de montaje con parte superior 1600x900  
esquina recta sin vidrio (S910-139)**

**Mounting Option with Top 1600x900  
straight corner without Glass (S910-139)**

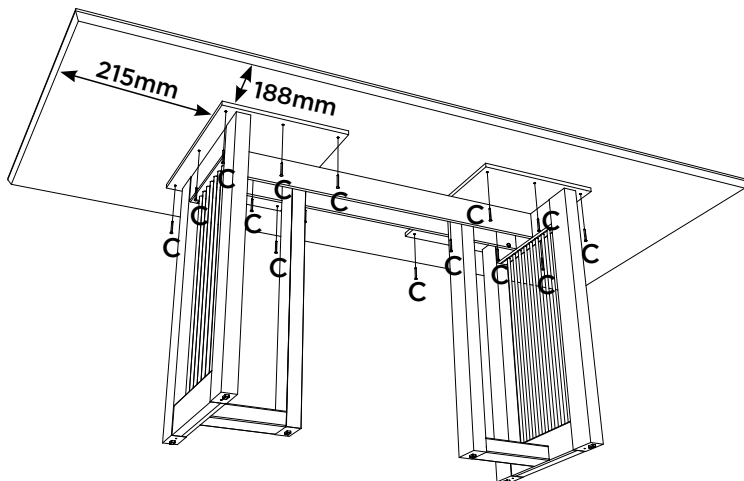

**Produto Concluído (S426 + S910)  
Producto Terminado (S426 + S910)  
Finished Product (S426 + S910)**

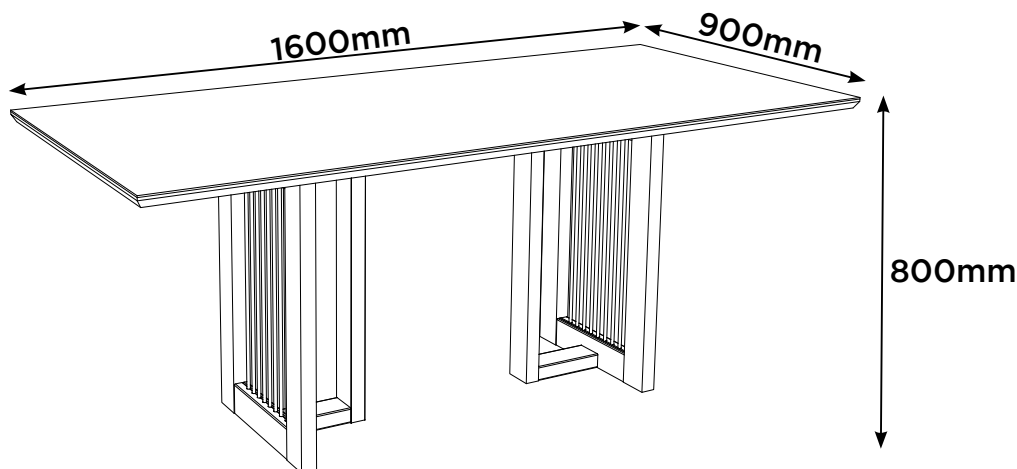

**Pesos máximos recomendados com carga distribuída**  
**Peso máximo recomendado con la carga distribuida**  
**Recommended maximum weight with distributed load.**

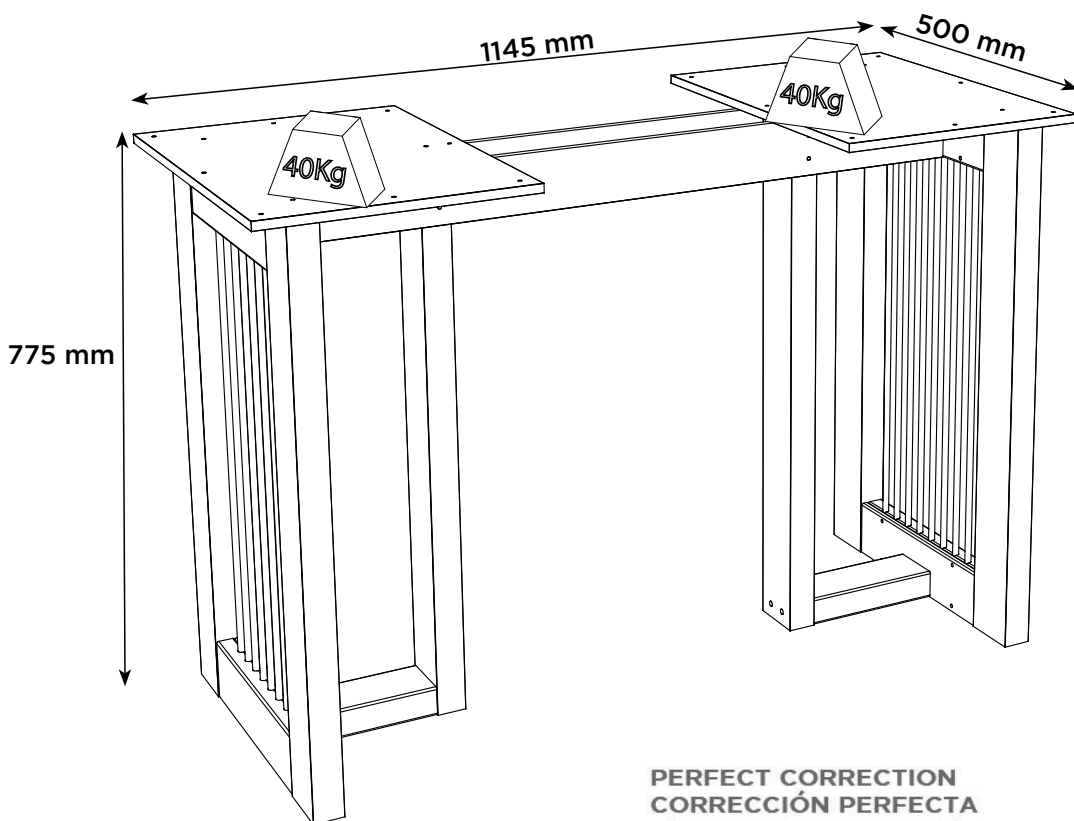

**PERFECT CORRECTION**  
**CORRECCIÓN PERFECTA**

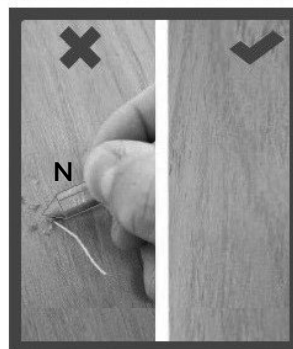
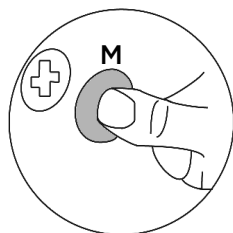

**Produto Concluído**  
**Producto terminado**  
**Finished Product**

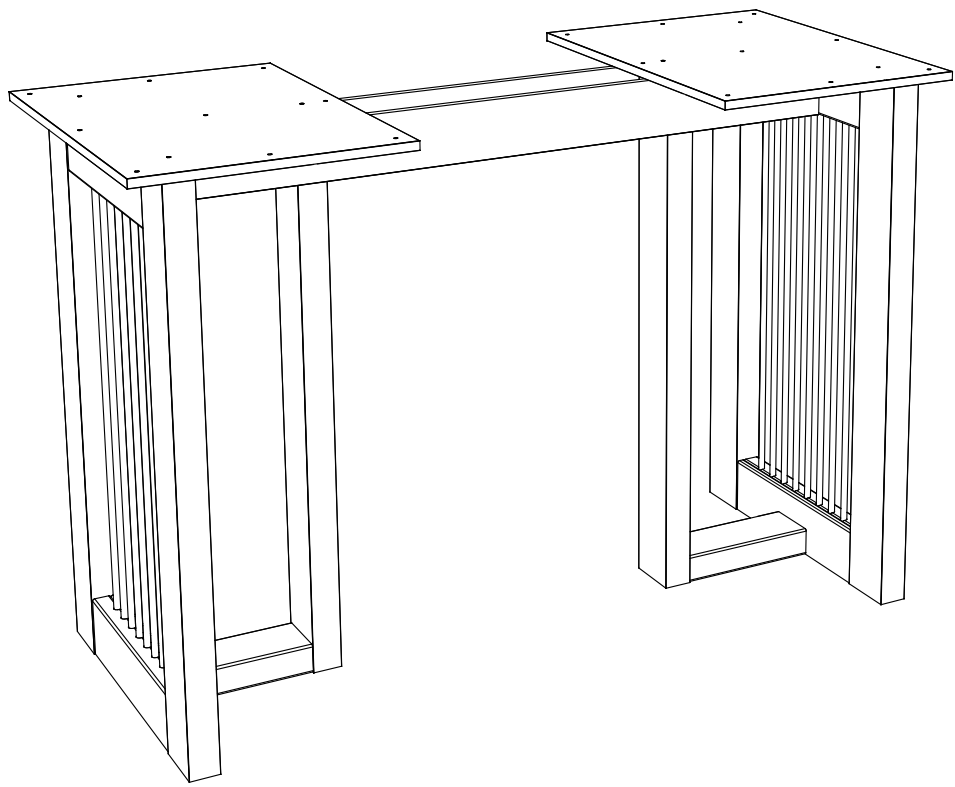

# HENN

Ind. e Com. de Móveis Henn  
Mondai - SC - Brasil

+55 49 3674.3500

@moveishenn  
www.henn.com.br

## INSTRUÇÕES DE MONTAGEM

INSTRUCCIONES DE MONTAJE  
ASSEMBLY INSTRUCTIONS

ITM/S34-

### CADEIRA ELOÁ

S34-502 Nature/Linho

S34-510 Nature/Marrom Amêndoa

S34-511 Nature/Marrom Expresso

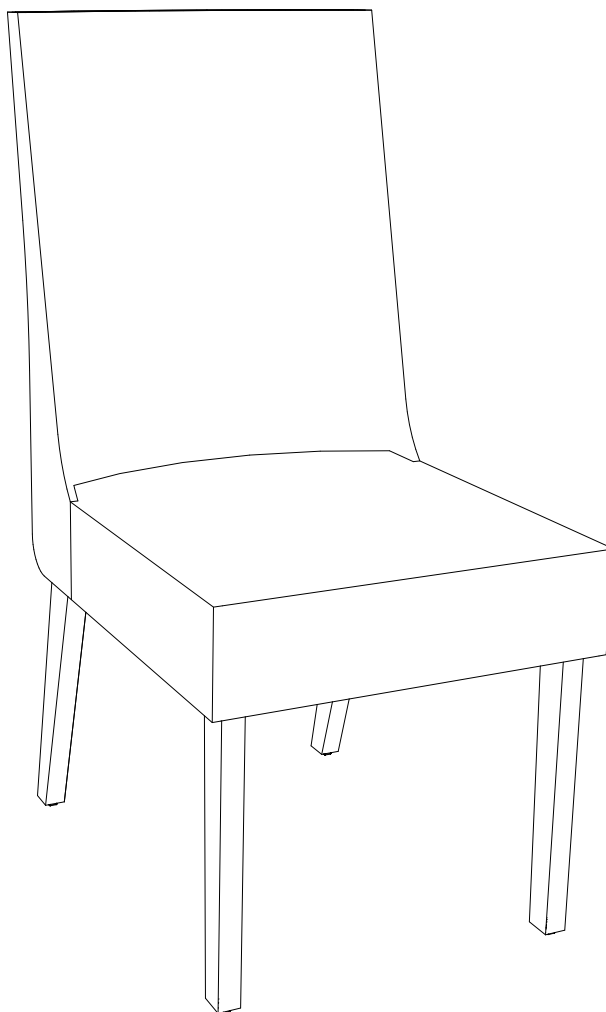

#### Requisitos para montagem Requisitor para la montaje Assembly Requirements

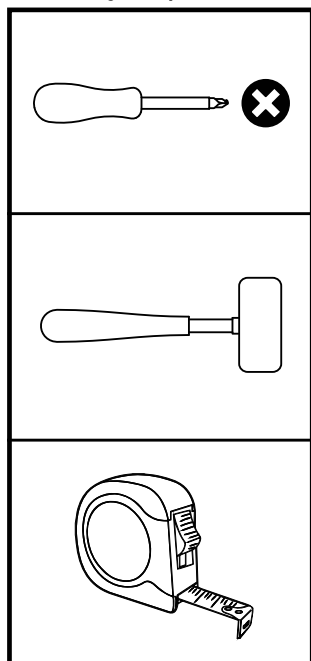

Imagens meramente ilustrativas,  
não acompanha o produto.  
Imágenes ilustrativas, no incluidas  
con el producto.  
Illustrative images, not included  
with the product.

#### AVISO

Para limpeza de seu móvel, use uma flanela seca ou umedecida, e não utilize produtos químicos que possam danificar seu produto.

#### SISTEMA DE MONTAGEM

O sistema de montagem dos produtos, funciona de acordo com a ordem crescente dos números indicados no desenho. Ex: 01, 02, 03, 04... até a conclusão da montagem.

#### ASSISTÊNCIA TÉCNICA

Para solicitação de Assistência Técnica você consumidor deverá entrar em contato com o Lojista o qual você realizou a compra deste produto e solicitar a assistência técnica das peças avariadas. A garantia abrange todas as peças, partes e componentes que eventualmente venham apresentar defeito de fabricação no prazo de 03 (três) meses, contando a partir da entrega do produto ao consumidor, mediante nota fiscal de compra. Se houver qualquer alteração na estrutura do produto ou ocorrer defeito por negligência do montador/consumidor em relação a instrução de montagem e manuseio, não será fornecido assistência técnica gratuita.

#### ADVERTENCIA

Para limpieza de su móvil, use una flanela seca o húmeda, y no utilice productos químicos que puedan dañar su producto.

#### SISTEMA DE MONTAJE

El sistema de montaje de los productos funciona de acuerdo con el orden creciente de los números indicados en el dibujo. Ej.: 01, 02, 03, 04... hasta la conclusión del montaje.

#### ASISTENCIA TÉCNICA

Para solicitar Asistencia Técnica, el consumidor debe comunicarse con el Comercio que usted realizó la compra de este producto y solicita asistencia técnica para las partes dañadas. La garantía cubre todas las partes, piezas y componentes que eventualmente puedan presentar defecto de fabricación en el plazo de 03 (tres) meses, contados a partir de la entrega del producto al consumidor, mediante factura de compra. Si se produce algún cambio en la estructura del producto o se produce un defecto por negligencia del montador/consumidor en relación con las instrucciones de montaje y manipulación, no se prestará asistencia técnica gratuita.

#### NOTICE

To clean your furniture, use a dry or wet cloth, and do not use chemicals that may damage your product.

#### ASSEMBLY SYSTEM

The products' assembly system works according to the increasing order of the indicated numbers. For example: 01, 02, 03, 04 ... to the end of the assembly.

#### TECHNICAL ASSISTANCE







To request Technical Assistance, the consumer must contact the retailer from whom you purchased this product and request technical assistance for the damaged parts. The warranty covers all parts, parts and components that may eventually present a manufacturing defect within a period of 03 (three) months, counting from the delivery of the product to the consumer, by means of a purchase invoice. If there is any change in the structure of the product or defect occurs due to negligence of the assembler/consumer in relation to the assembly and handling instruction, free technical assistance will not be provided.

# 1 Pré Montagem Preasamblea | Pre-assembly

## Peças Necessárias | Partes requeridas | Required Parts:

3	Pé Frontal   Pie delantero   Front foot	04
4	Pé Traseiro   Pie trasero   Back foot	04
5	Travessa Lateral   Plato lateral   Side Platter	04
6	Travessa   Plato   Platter	04

## Ferragens | Herrajes | Hardware:

D		x24
E		x24
F		x08
G		x16
I		
K		

## Ferramentas | Instrumentos | Tools:

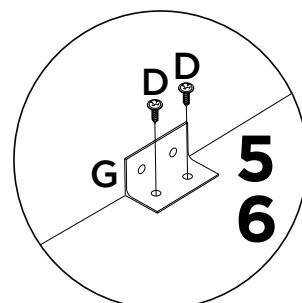
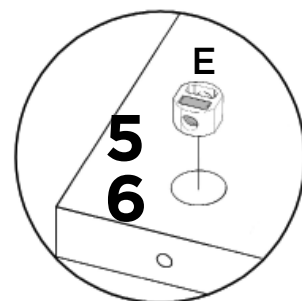
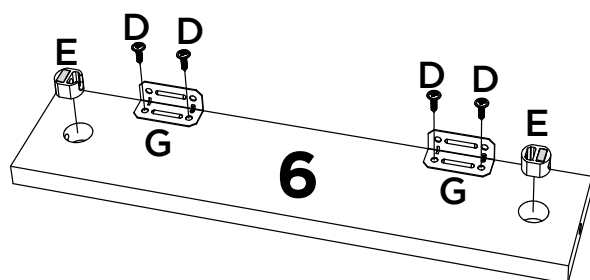
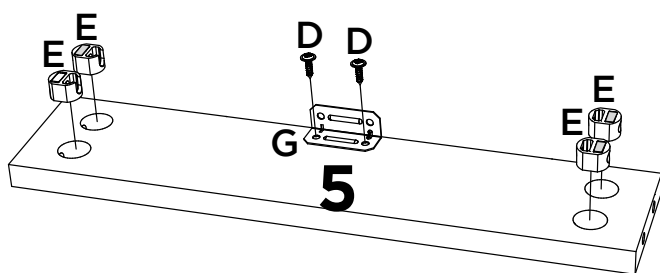
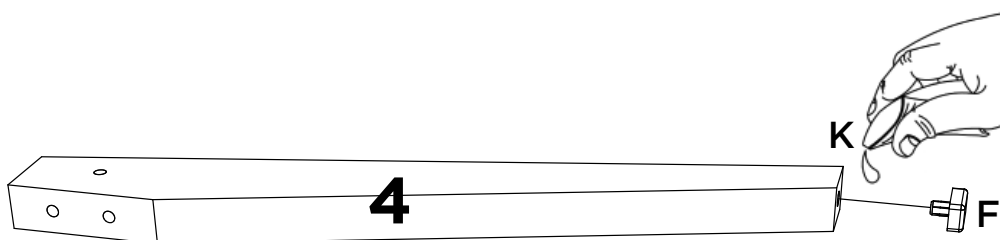
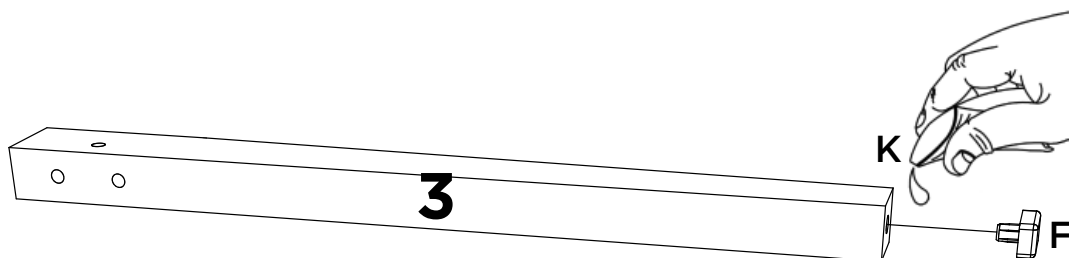
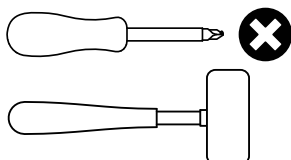





# 2

## Peças Necessárias | Partes requeridas | Required Parts:

1	Encosto Estofado   Respaldo tapizado   Upholstered backrest	02
2	Assento Estofado   Asiento tapizado   Upholstered seat	02

## Ferragens | Herrajes | Hardware:

C		x06
H		x16
I		
K		

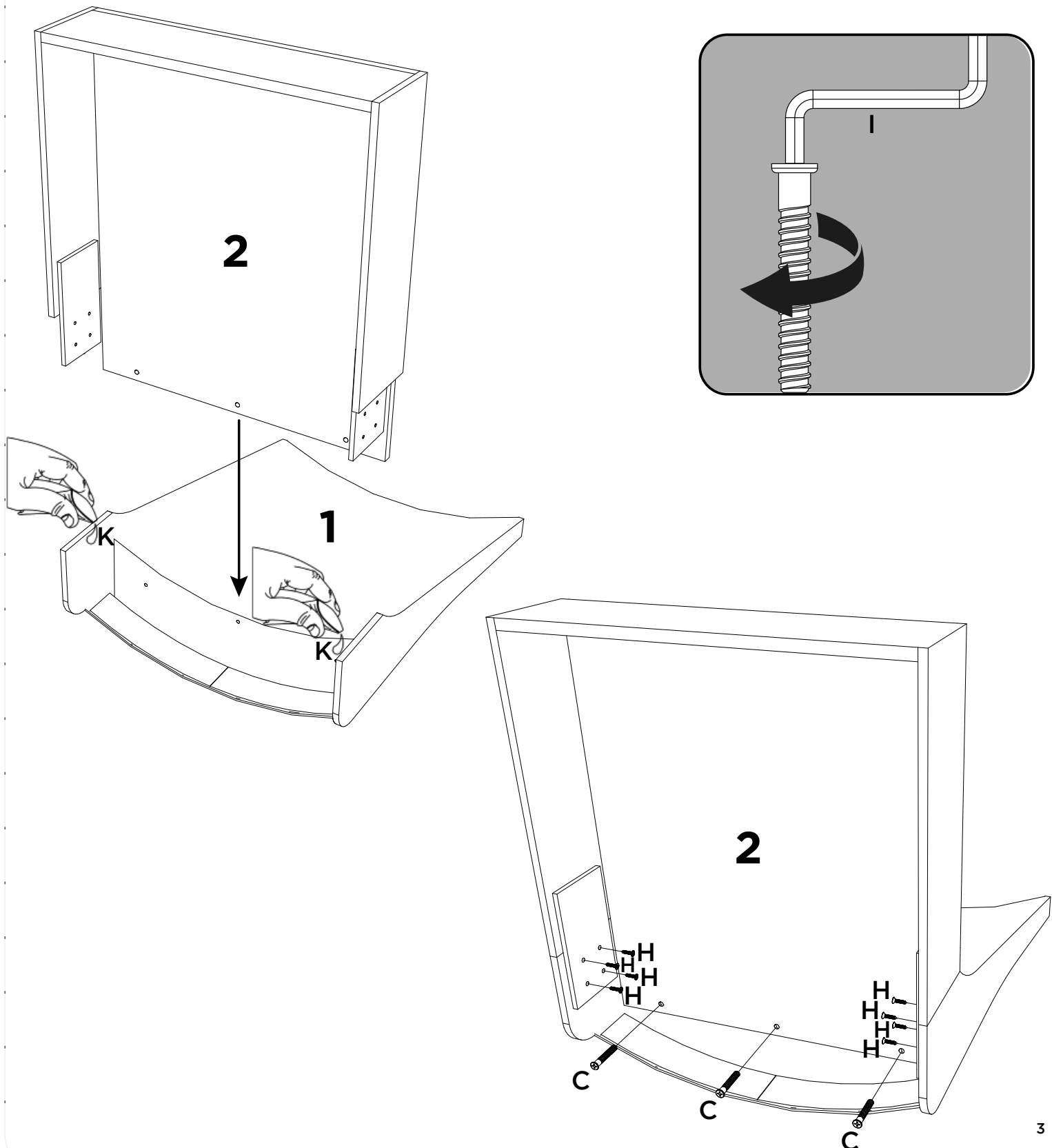



## 3

## Peças Necessárias | Partes requeridas | Required Parts:

3	Pé Frontal   Pie delantero   Front foot	04
4	Pé Traseiro   Pie trasero   Back foot	04
5	Travessa Lateral   Plato lateral   Side Platter	04

## Ferragens | Herrajes | Hardware:

A		x16
I		

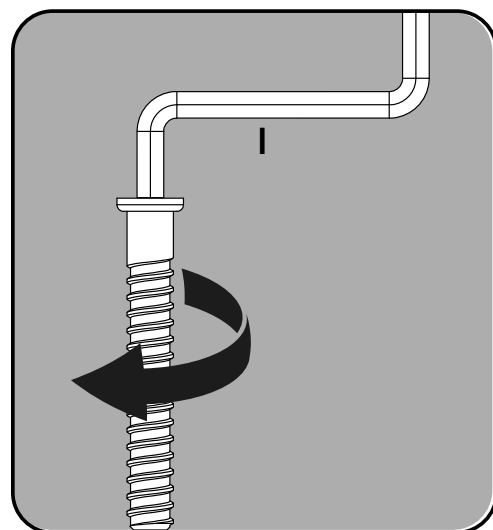
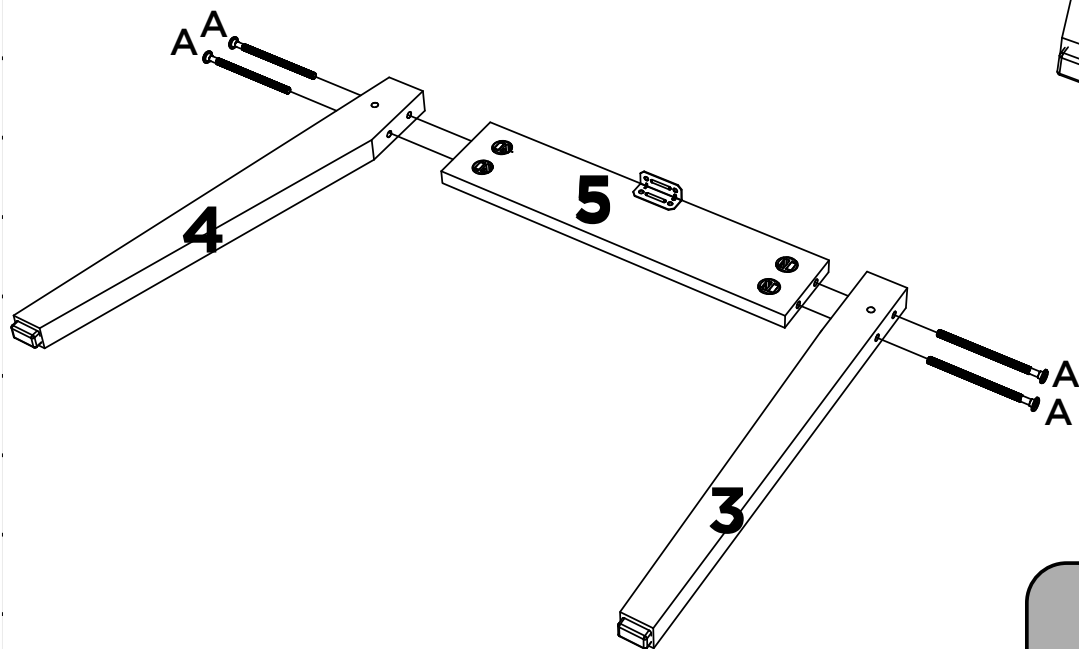
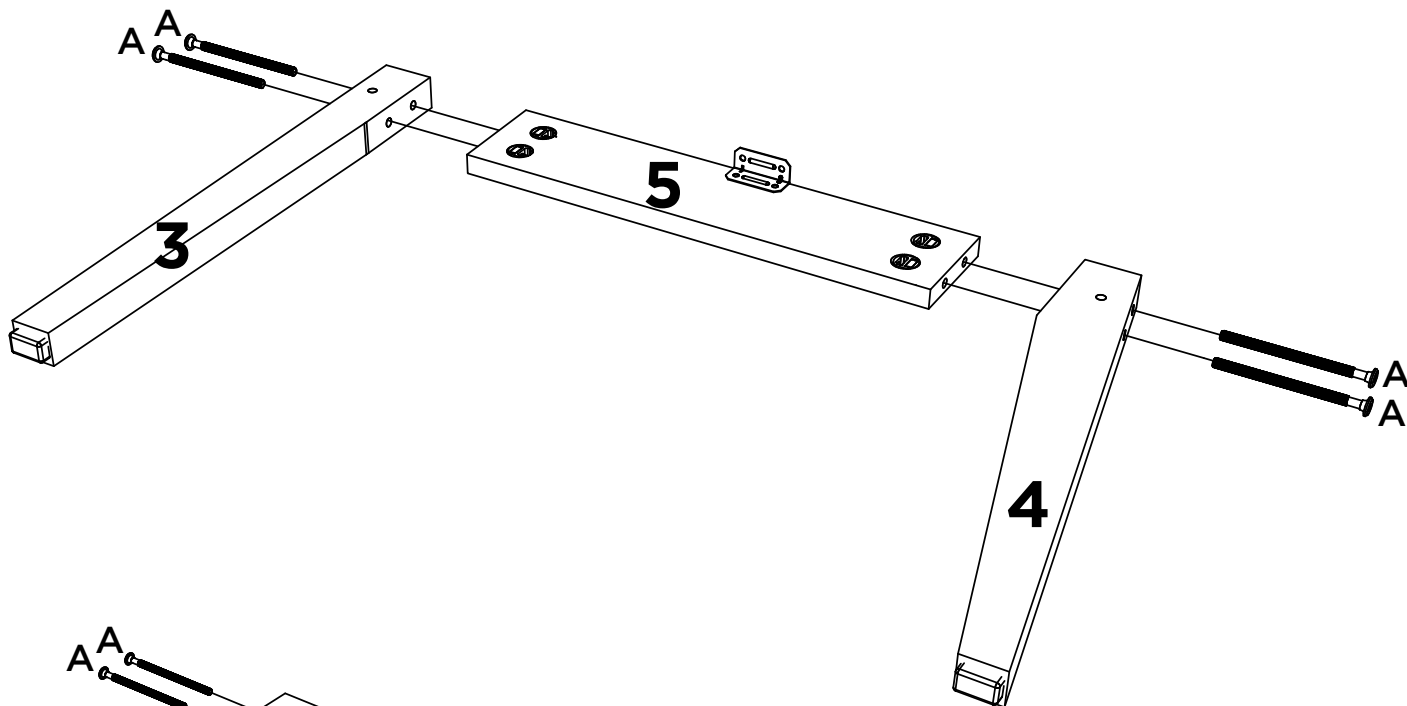





## 4

## Peças Necessárias | Partes requeridas | Required Parts:

6	Travessa   Plato   Platter	04
---	----------------------------	----

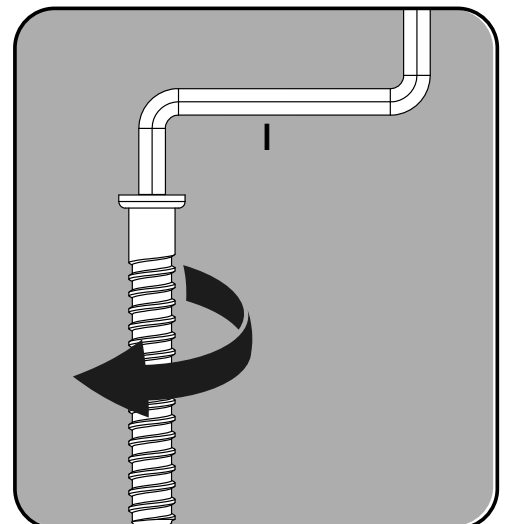
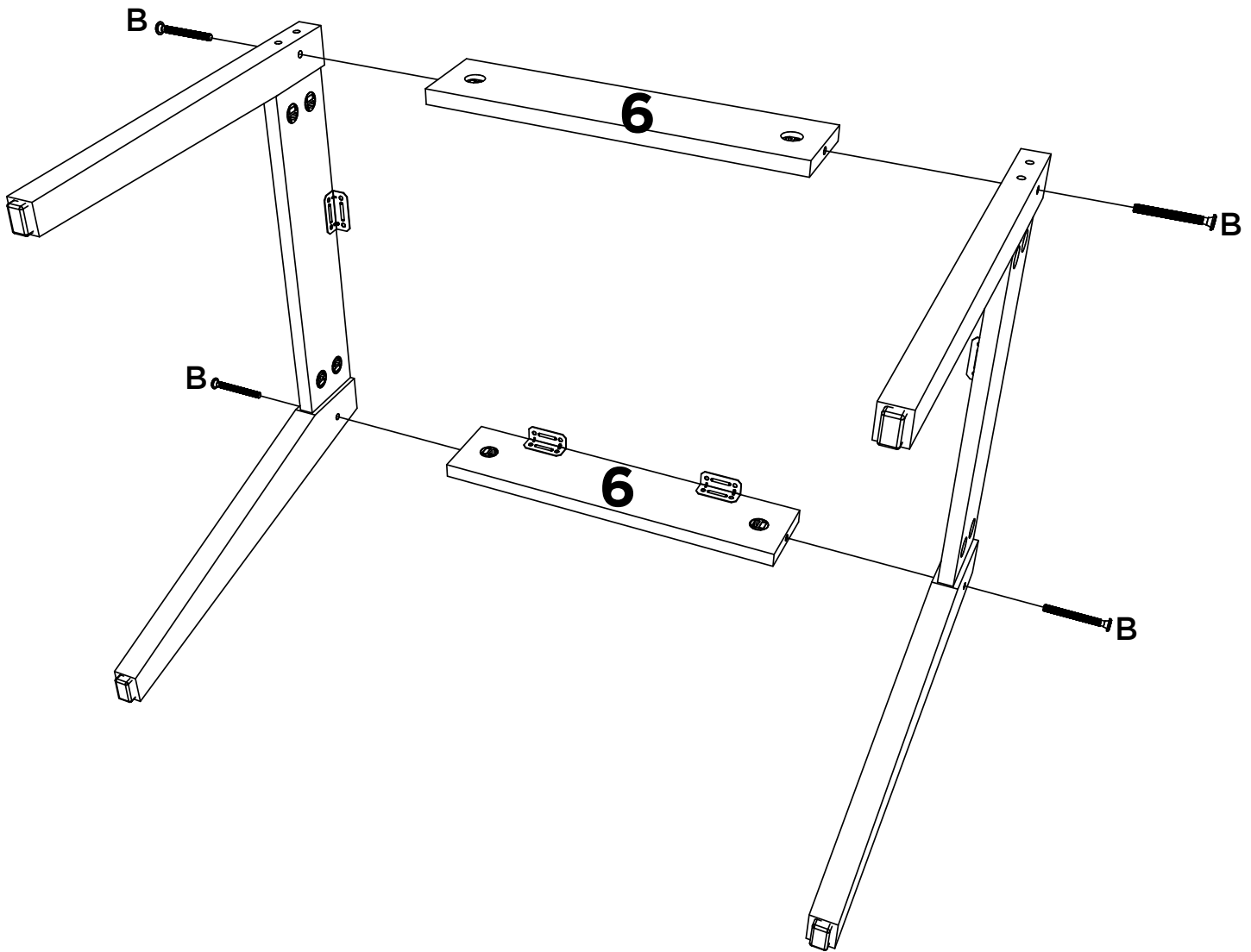

## Ferragens | Herrajes | Hardware:

B		x08
I		



## 5

Ferragens | Herrajes | Hardware:

D		x40
J		x08

Ferramentas | Instrumentos | Tools:

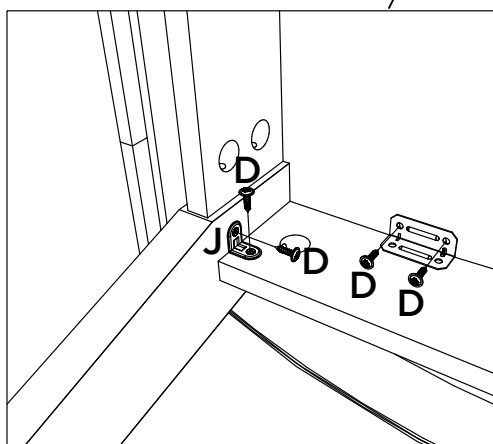
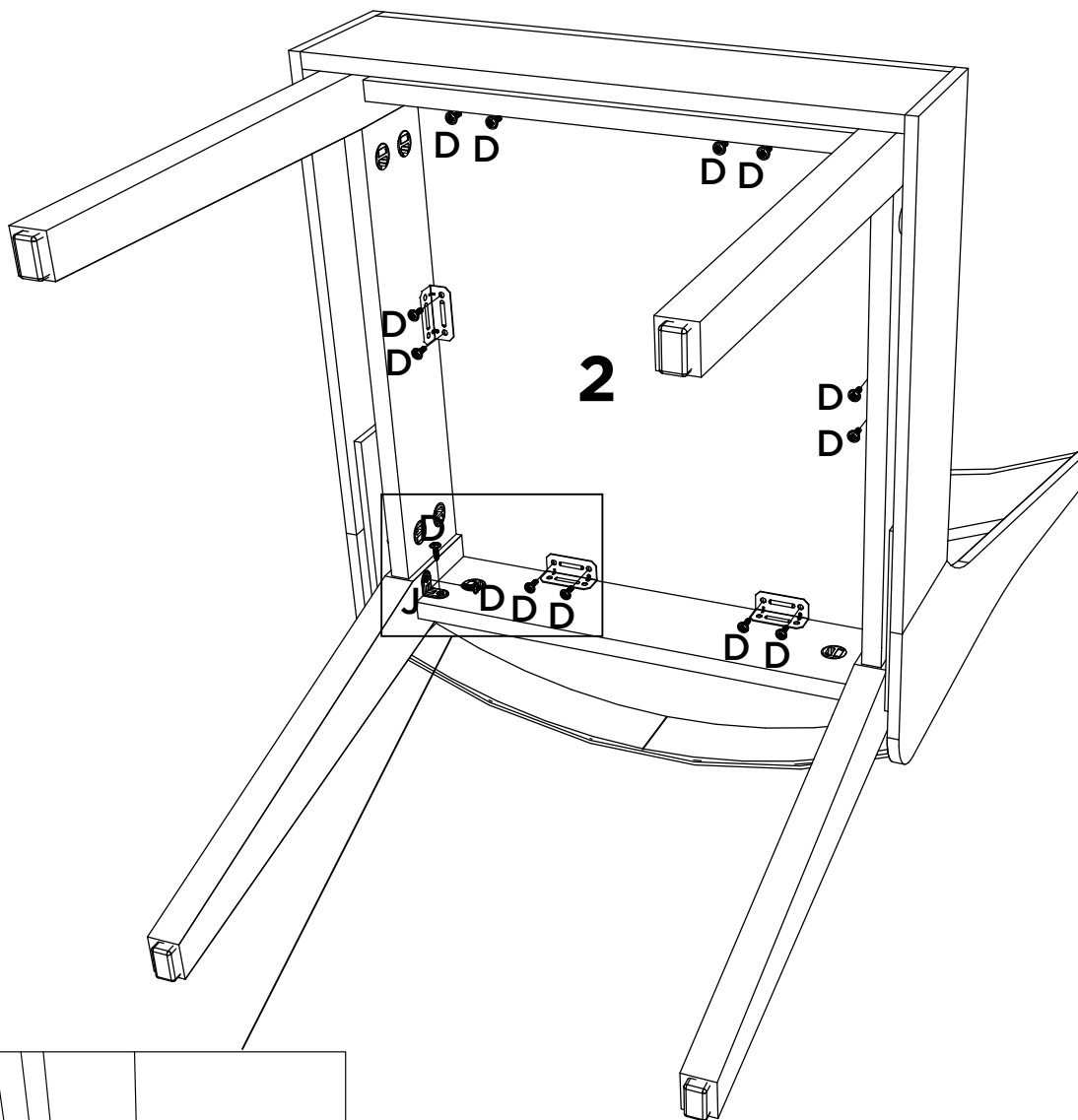
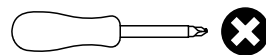

\*Cantoneira de metal (J) nos quatro cantos da cadeira, o mais próximo possível da borda inferior.

\*Soporte angular de metal (J) en las cuatro esquinas de la silla, las más cercanas posible desde el borde inferior.

\*Metal angle bracket (J) on all four corners of the chair, the closest possible from the bottom edge.

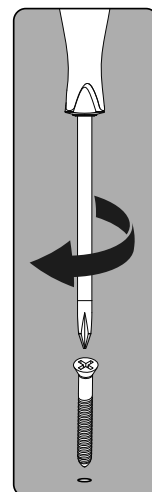
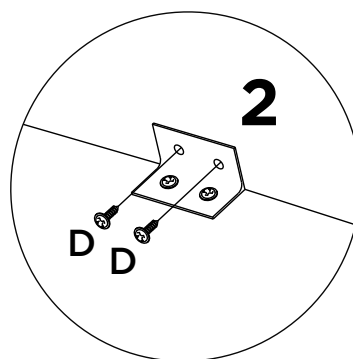

6

Ferragens | Herrajes | Hardware:

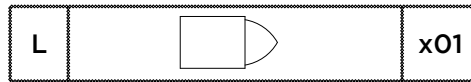

Pesos máximos recomendados com carga distribuída  
 Peso máximo recomendado con la carga distribuida  
 Recommended maximum weights with evenly distributed.

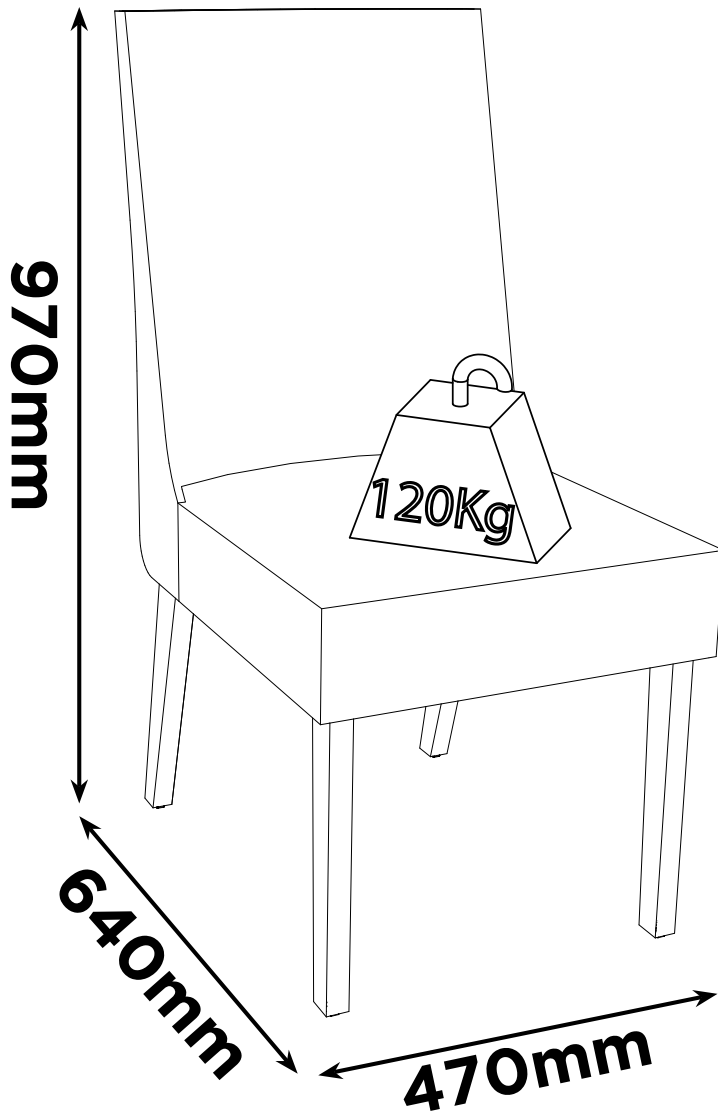

PERFECT CORRECTION  
 CORRECCIÓN PERFECTA

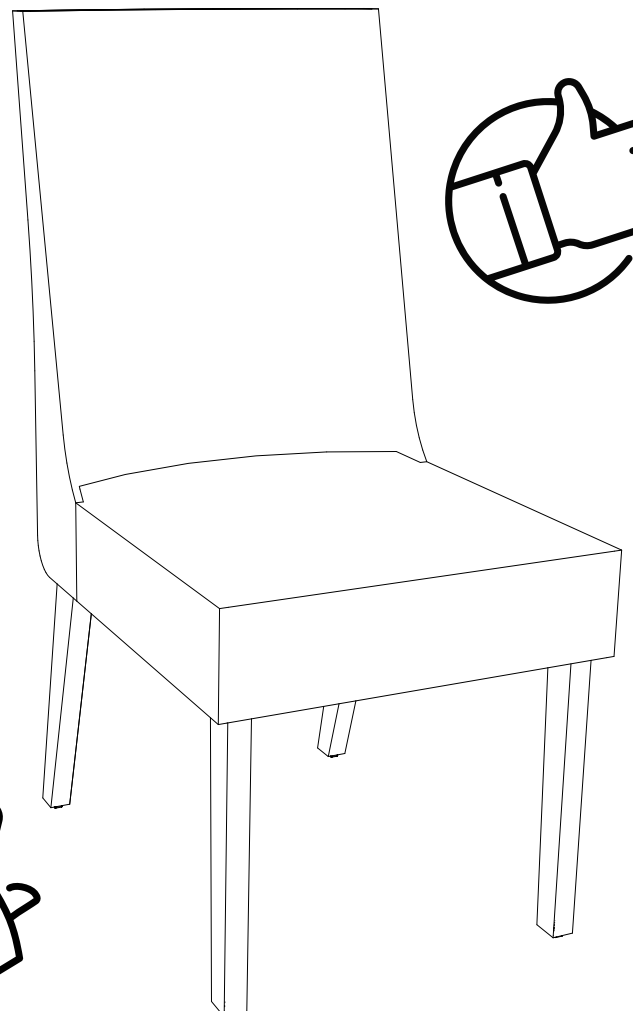
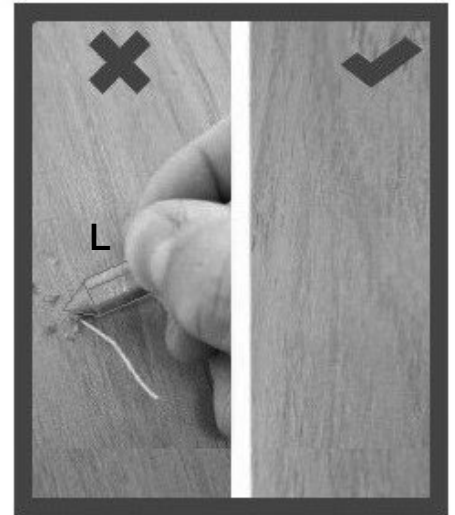





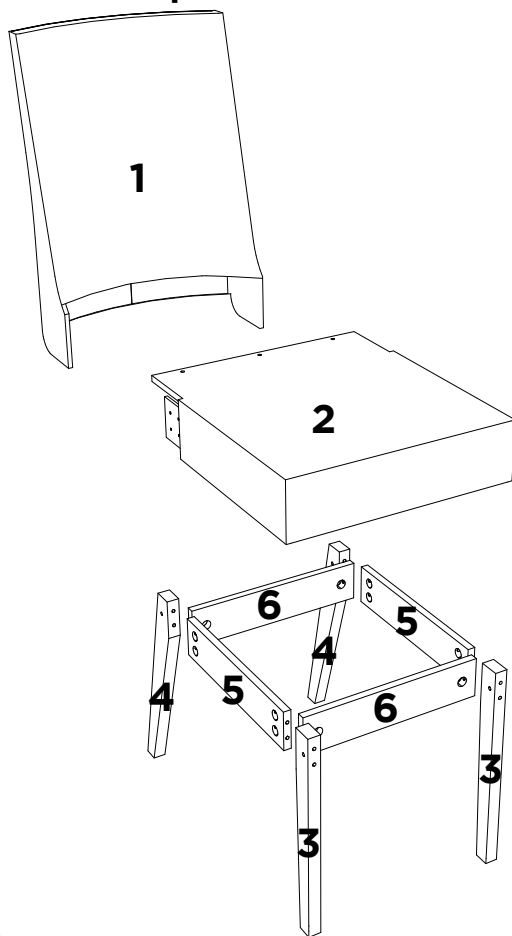

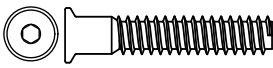

Item	Caixa Caja Box	Qtd Ctd Qty	Descrição   Descripción   Description	Medidas (mm)   Dimensions (mm)   Size (measurements) (mm)
01	1/1	02	Encosto Estofado   Respaldo tapizado   Upholstered backrest	665x460x185
02	1/1	02	Assento Estofado   Asiento tapizado   Upholstered seat	510x460x155
03	1/1	04	Pé Frontal   Pie delantero   Front foot	425x40x25
04	1/1	04	Pé Traseiro   Pie trasero   Back foot	425x130x25
05	1/1	04	Travessa Lateral   Plato lateral   Side Platter	366x80x15
06	1/1	04	Travessa   Plato   Platter	366x80x15

O volume contém peças para montagem de 2 Cadeiras.  
El volumen contiene piezas para montar 2 sillas.  
The volume contains parts for mounting 2 Chairs.

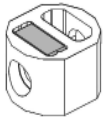
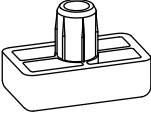
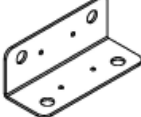

Ferragens | Herrajes | Hardware

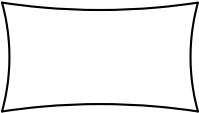
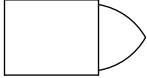
<p><b>A</b> 16x</p>  <p>Parafuso Cab PL 17 Allen 4.14x3,12 (80mm) Tornillo PL 17 Allen 4.14x3.12 (80mm) Screw PL 17 Allen 4.14x3.12 (80mm)</p>	<p><b>B</b> 08x</p>  <p>Parafuso Cab PL 17 Allen 4.14x3,12 (60mm) Tornillo PL 17 Allen 4.14x3.12 (60mm) Screw PL 17 Allen 4.14x3.12 (60mm)</p>	<p><b>C</b> 06x</p>  <p>Parafuso 7,0x40mm CHT Allen Tornillo Allen CHT de 7,0x40 mm Screw 7.0x40mm CHT Allen</p>	<p><b>D</b> 64x</p>  <p>Parafuso 3,5x14mm FLA Tornillo 3,5x14mm FLA Screw 3,5x14mm FLA</p>
<p><b>E</b> 24x</p>  <p>Porca meia lua plástica rosca 1/4 1/4 tuerca de media luna de plástico 1/4 plastic half moon nut</p>	<p><b>F</b> 08x</p>  <p>Sapata Deslizante 15x26x8mm Zapato deslizante 15x26x8mm Sliding Shoe 15x26x8mm</p>	<p><b>G</b> 12x</p>  <p>Cantoneira 17,5x17,5x44 Cantonera 17,5x17,5x44 Angle 17,5x17,5x44</p>	<p><b>H</b> 16x</p>  <p>Parafuso 3,0x16mm CHT Tornillo 3,0x16mm CHT Screw 3,0x16mm CHT</p>
<p><b>I</b> 01x</p>  <p>Chave Allen llave Allen Allen key</p>	<p><b>J</b> 08x</p>  <p>Cantoneira metal 18x18 Cantonera metálica 18x18 18x18 metal angle bracket</p>	<p><b>K</b> 01x</p>  <p>Sachê de cola Bolsa de pegamento Glue bag</p>	<p><b>L</b> 01x</p>  <p>Giz de correção Tiza de corrección Chalk of correction</p>