

# ASSEMBLY INSTRUCTIONS MANUAL DE MONTAGEM / INSTRUCCIONES DE ARMADO

FLORENCE TABLE  
MESA FLORENCE  
MESA FLORENCE

Reference **230165** | Revise **00**  
Referência | Revisão  
Referencia | Revisión

 ENGLISH  
PORTUGUÊS  
ESPAÑOL

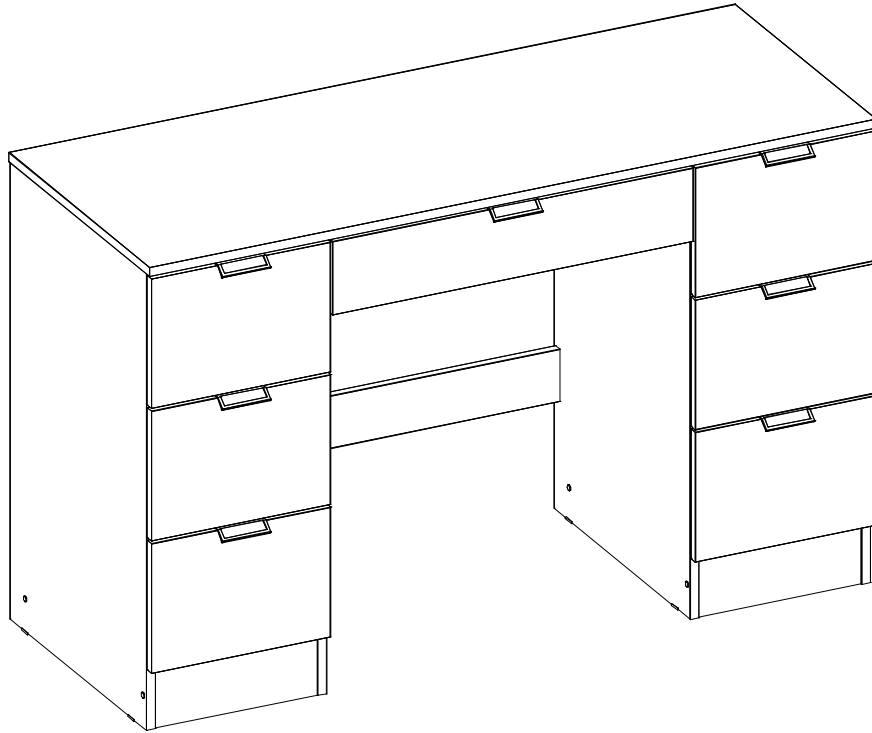

MAXIMUM RECOMMENDED WEIGHT  
BEING THIS EVENLY DISTRIBUTED.

PESO MÁXIMO RECOMENDADO SENDO  
ESTE DISTRIBUÍDO UNIFORMEMENTE.

PESO MÁXIMO RECOMENDADO SIENDO  
ESTE UNIFORMEMENTE DISTRIBUIDO.

	LB	KG
–		
C	6	3
H	44	20

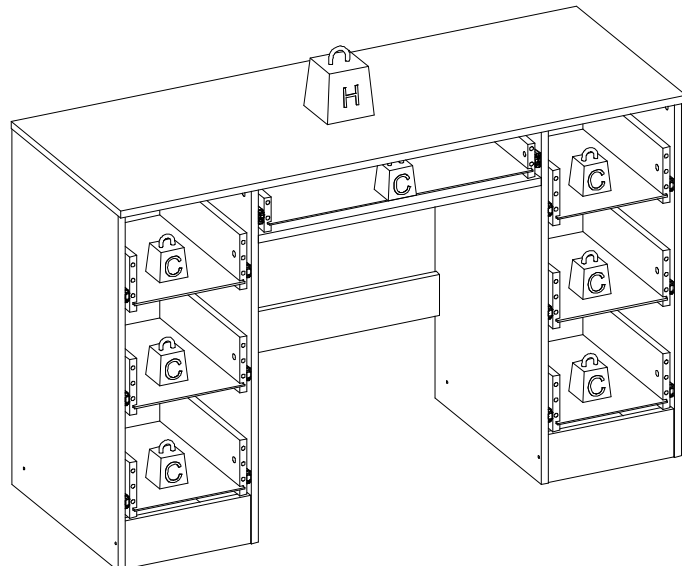

Nº	Measures_Inches	Medidas_cm	Qty./Qtd.
01	47 1/4 x 18 1/4 x 5/8	120.0 x 46.5 x 1.5	1
02	29 1/8 x 17 3/4 x 5/8	74.0 x 45.0 x 1.5	1
03	29 1/8 x 17 3/4 x 5/8	74.0 x 45.0 x 1.5	1
04	29 1/8 x 17 3/4 x 5/8	74.0 x 45.0 x 1.5	1
05	29 1/8 x 17 3/4 x 5/8	74.0 x 45.0 x 1.5	1
07	23 5/8 x 3 3/8 x 5/8	60.0 x 8.5 x 1.5	2
08	10 1/2 x 3 7/8 x 5/8	26.8 x 10.0 x 1.5	2
09	10 1/2 x 2 3/4 x 5/8	26.8 x 7.0 x 1.5	2
10	11 5/8 x 8 1/4 x 5/8	29.6 x 21.0 x 1.5	6
11	23 1/2 x 4 5/8 x 5/8	59.6 x 11.9 x 1.5	1
12	8 5/8 x 4 1/2 x 5/8	21.9 x 11.5 x 1.5	6
13	21 1/2 x 2 3/4 x 5/8	54.5 x 7.0 x 1.5	1
14	13 7/8 x 9 1/8 x 1/8	35.4 x 23.3 x 0.3	6
15	22 x 11 3/4 x 1/8	55.9 x 29.9 x 0.3	1
16	27 1/2 x 11 1/4 x 1/8	69.9 x 28.6 x 0.3	2
17	24 1/8 x 3 7/8 x 1/8	61.4 x 10.0 x 0.3	1
96	14 x 4 1/2 x 5/8	35.5 x 11.5 x 1.5	6
97	14 x 4 1/2 x 5/8	35.5 x 11.5 x 1.5	6
108	11 3/4 x 2 3/4 x 5/8	30.0 x 7.0 x 1.5	1
109	11 3/4 x 2 3/4 x 5/8	30.0 x 7.0 x 1.5	1

**PARTS IDENTIFICATION  
IDENTIFICAÇÃO DAS PEÇAS / IDENTIFICACIÓN DE LAS PIEZAS**

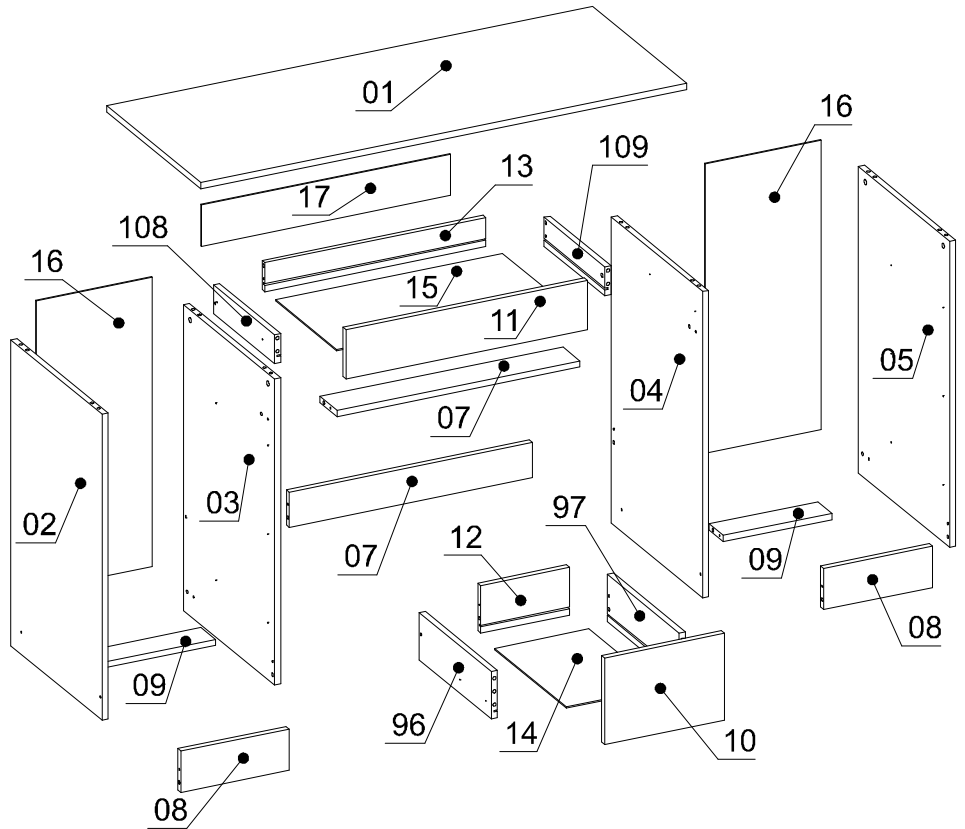

**YOU WILL NEED / VOCÊ VAI PRECISAR DE / USTED NECESITARÁ**

Tools not supplied / Ferramentas não fornecidas / Herramientas no incluidas

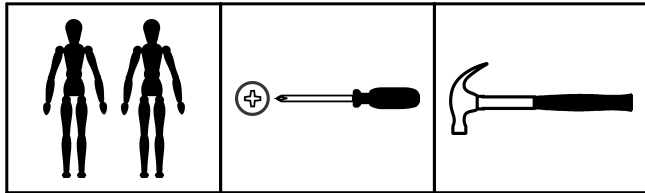

2 People  
2 Pessoas  
2 Personas

Screwdriver Phillips  
Chave Phillips  
Destornillador cruz

Hammer  
Martelo  
Martillo













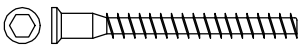

The separation of the accessories before you start the assembly will facilitate the same. In case of doubt on the size of the screws and bolts, use the ruler to bottom of page 3.

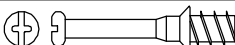
A separação dos acessórios antes de iniciar a montagem facilitará a mesma. Em caso de dúvida no tamanho dos parafusos e cavilhas, utilize a régua ao final da página 3.

La separación de los accesorios antes de comenzar el armado facilitará el mismo. En caso de duda sobre el tamaño de los tornillos y taquetes, utilice la regla al pie de página 3.

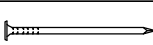
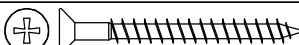
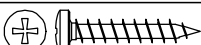
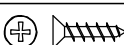
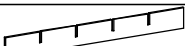
## IDENTIFICATION OF ACCESSORIES IDENTIFICAÇÃO DOS ACESSÓRIOS/ IDENTIFICACIÓN DE ACCESORIOS

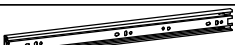
A1		Glue / Cola / Pegamento	13 g	1
A3		Trapeze / Trapézio / Trapecio	-	2
B27		Handle / Puxador Cristales / Tirador	64mm	7
E		Wooden dowel / Cavilha / Taquete	8x30 mm	62
E7		Small plastic foot / Sapata / Pie plástico	15 mm	8
G		Structural screw / Parafuso estrutural / Tornillo estructural	5,0x50 mm	12
H		Allen key / Chave allen / Liave allen	3 mm	1
I		Structural screw cover/Tampa parafuso estrutural/Tapa tornillo estructural	-	8
J		Simple minifix screw / Haste minifix simples / Tornillo minifix simple	-	20
L		Drum lock / Tambor minifix / Tambor minifix	12 mm	20
L17		Telescopic slide / Corrediça telescópica / Corredera telescópica	350 mm	12
M		Bore patch adhesive / Tapa furo adesivo / Tapones adhesivo	-	12
N		Nail / Prego / Clavo	10x10	52
O		Flat head screw / Parafuso chato / Tornillo de cabeza plana	4,5x45 mm	14
P		Pan head screw / Parafuso panela / Tornillo de pan	4,5x25 mm	2
P5		Flat head screw / Parafuso chato especial / Tornillo de cabeza plana	3,5x14 mm	70
Q14A		Drawer divider / Divisor de gavetas / Divisor de cajón	544mm	2
Q14B		Drawer divider / Divisor de gavetas / Divisor de cajón	284mm	4
S10		Telescopic slide / Corrediça telescópica / Corredera telescópica	300 mm	2



PRE-ASSEMBLE  
PRÉ-MONTAGEM / PRE ARMADO

01

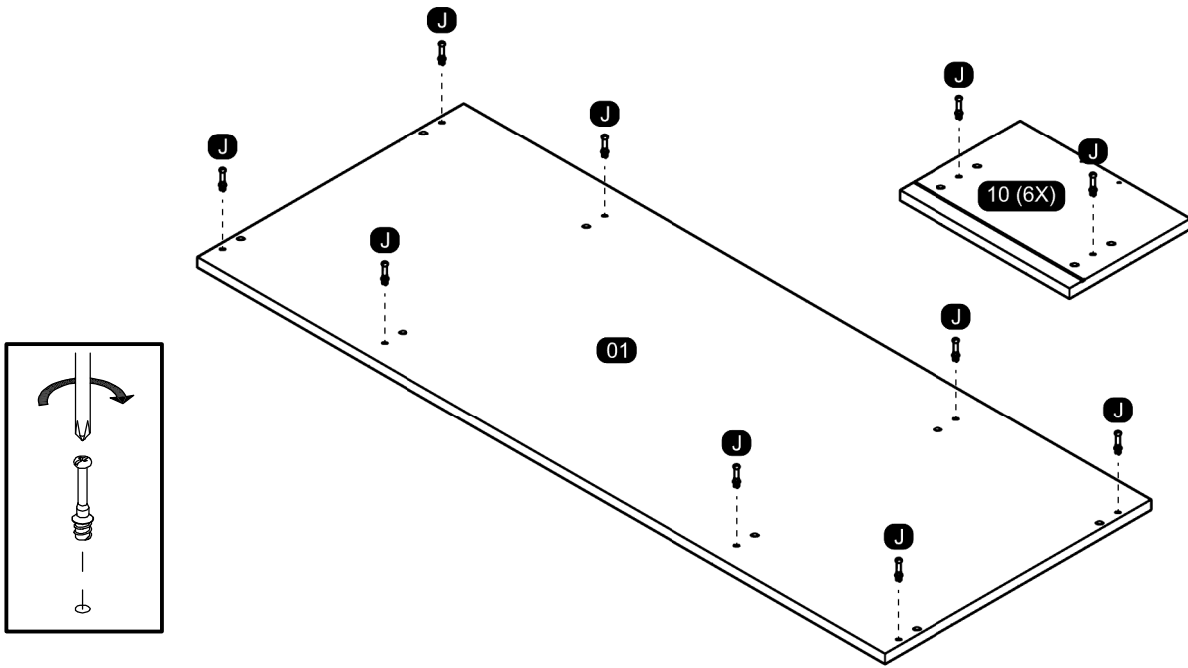

02

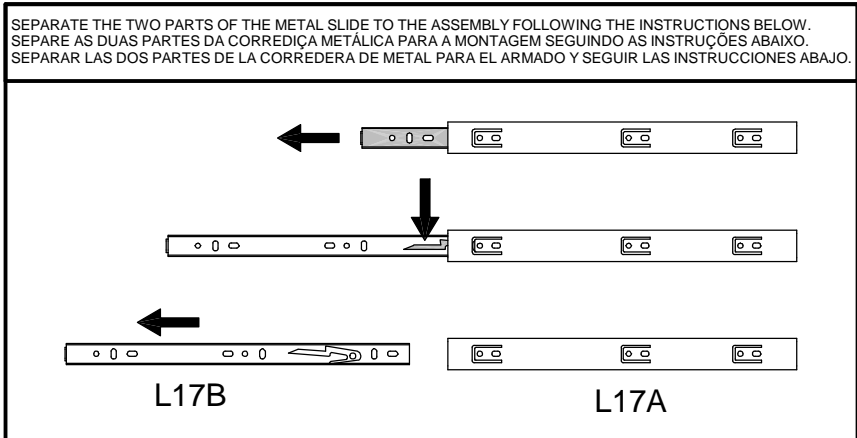

03

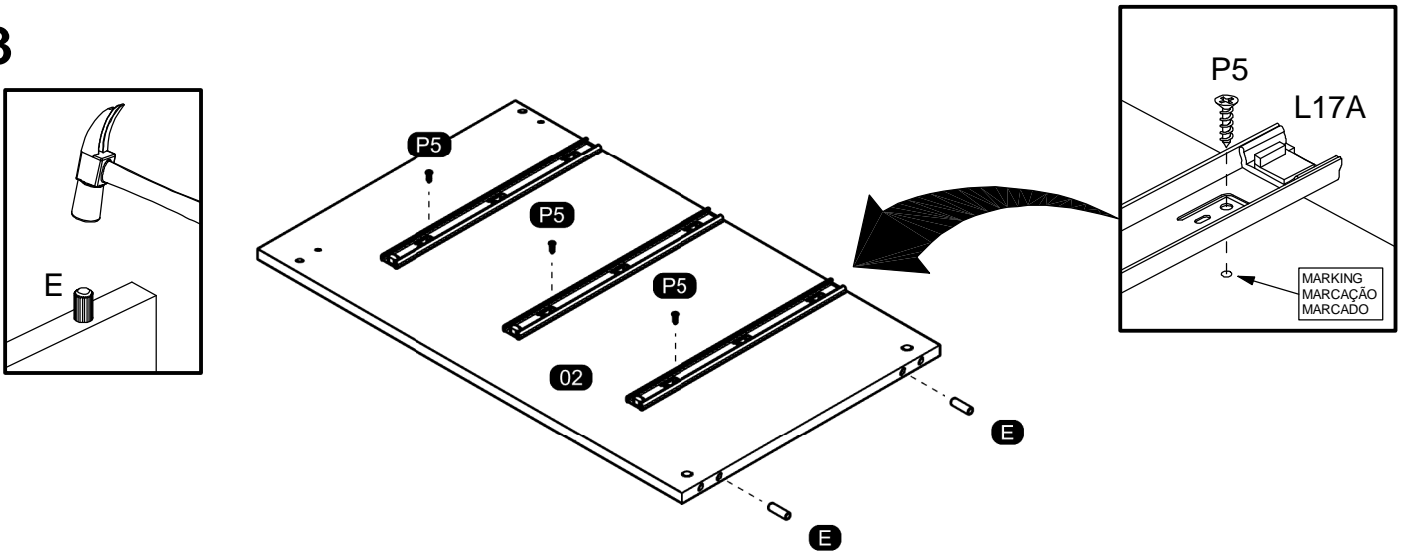

04

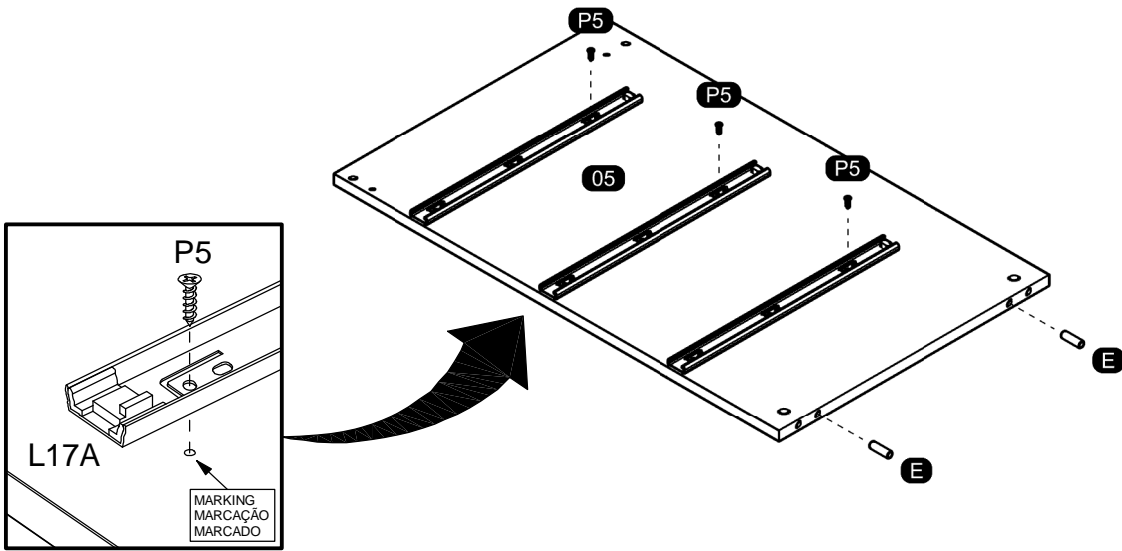

05

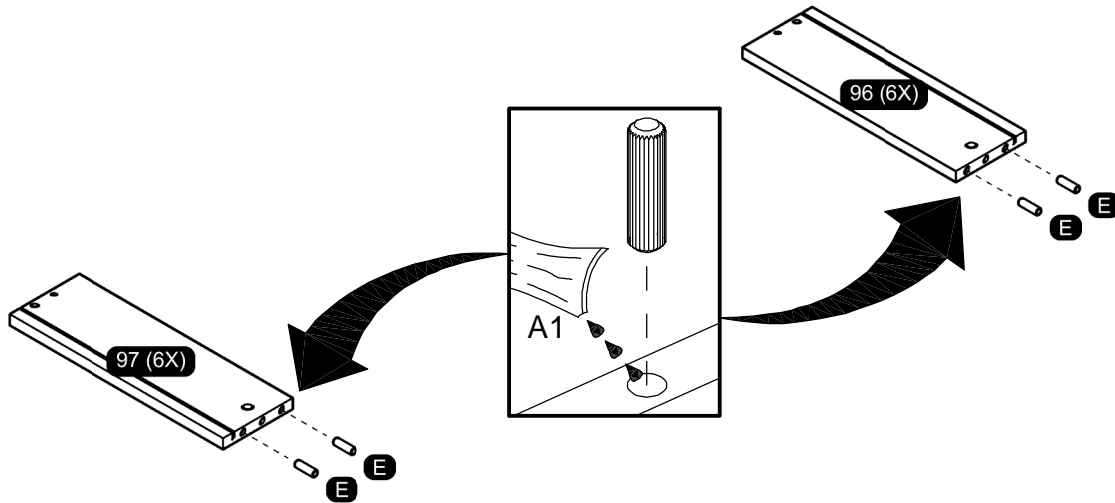

06

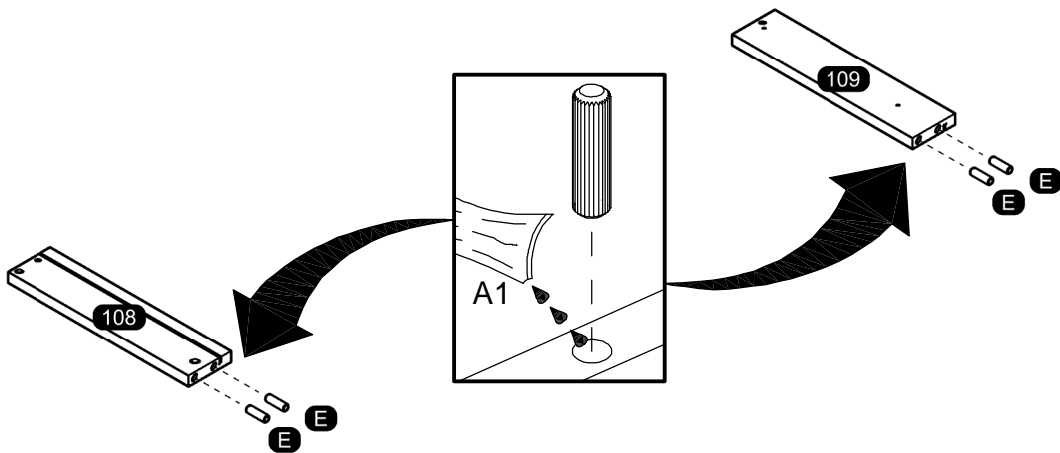

07

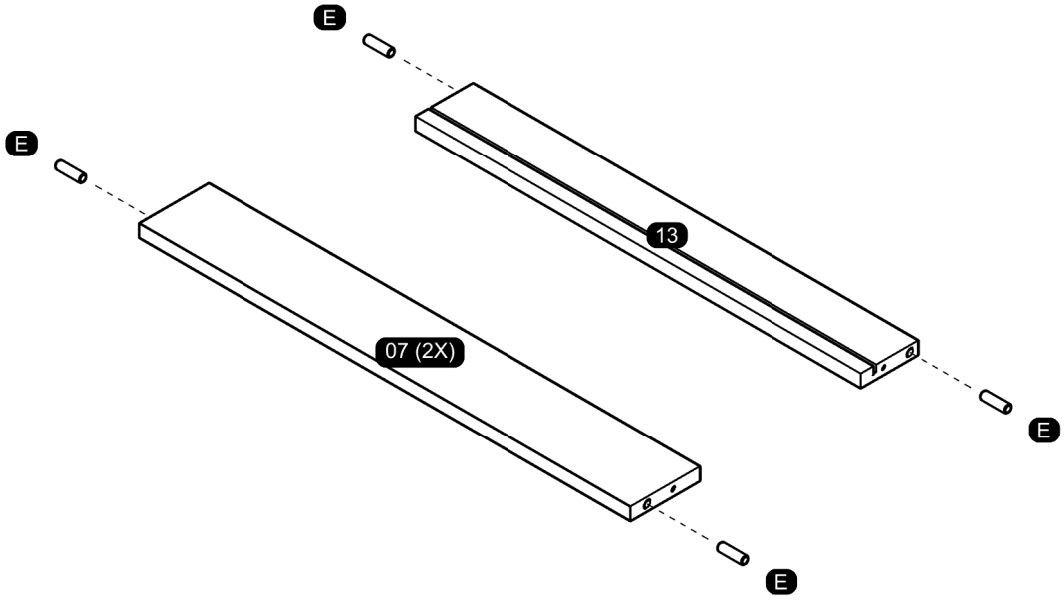

08

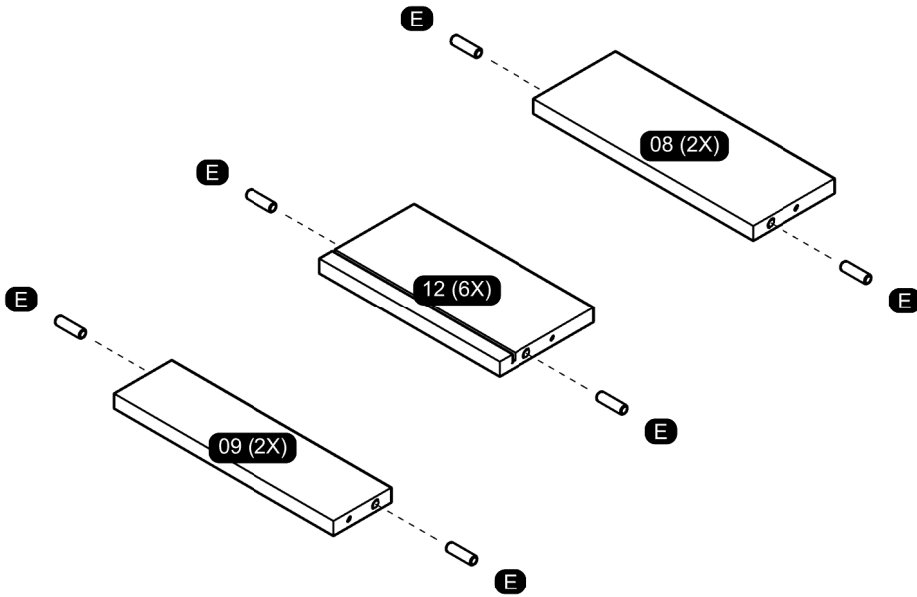

09

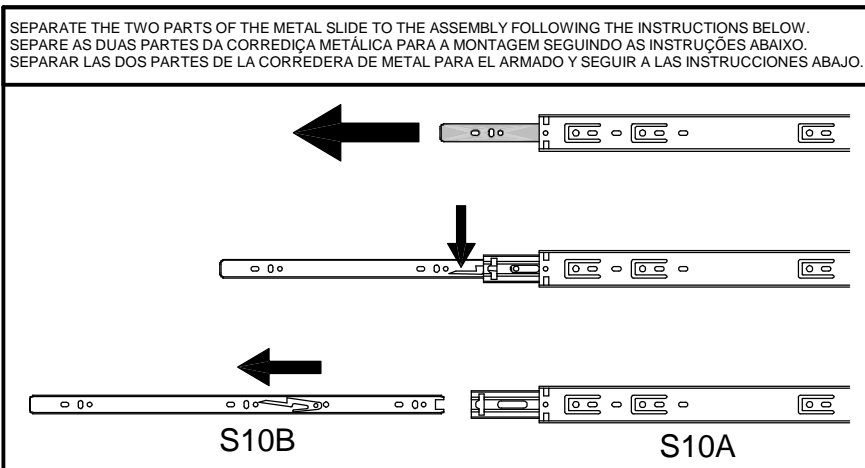

10

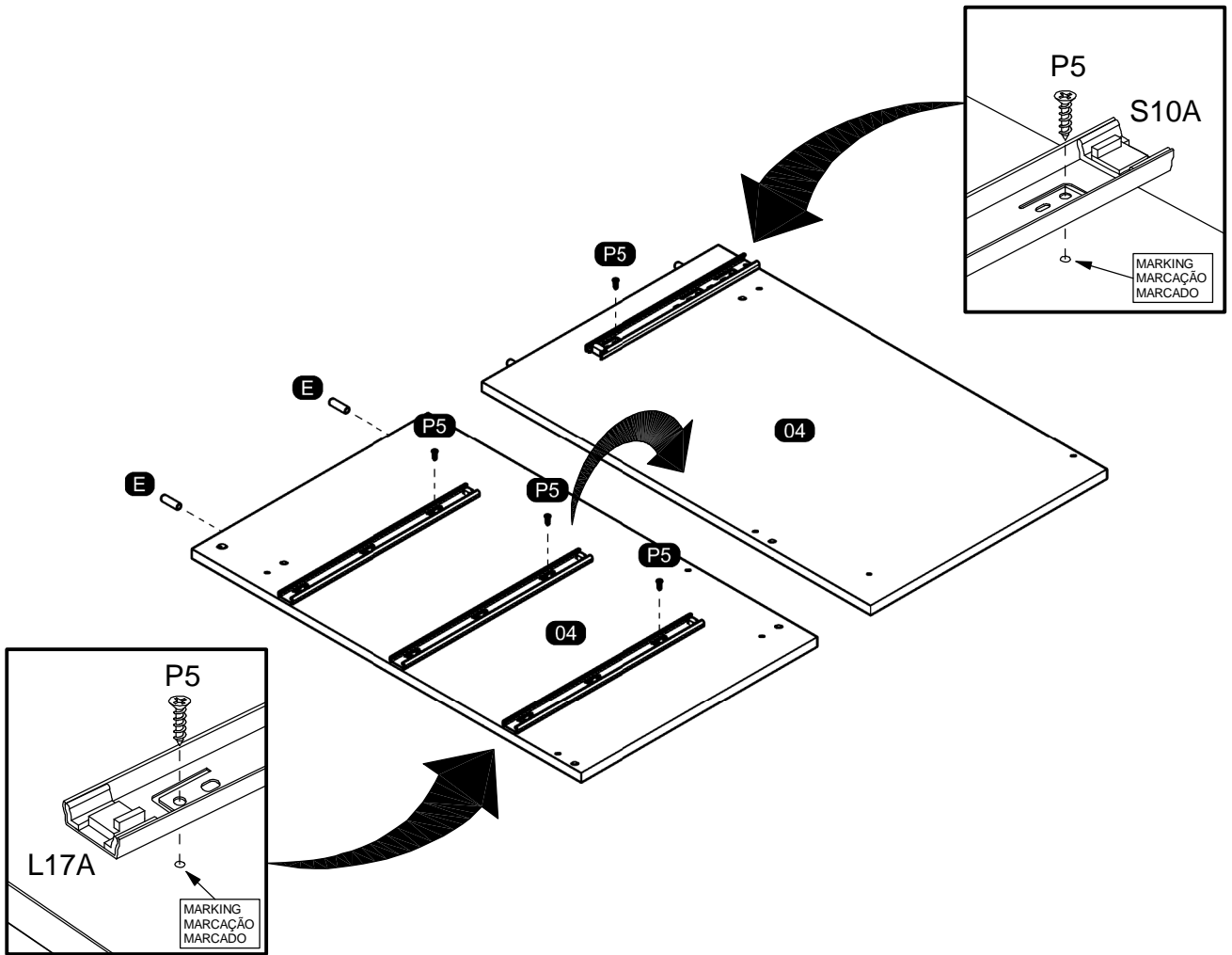

11

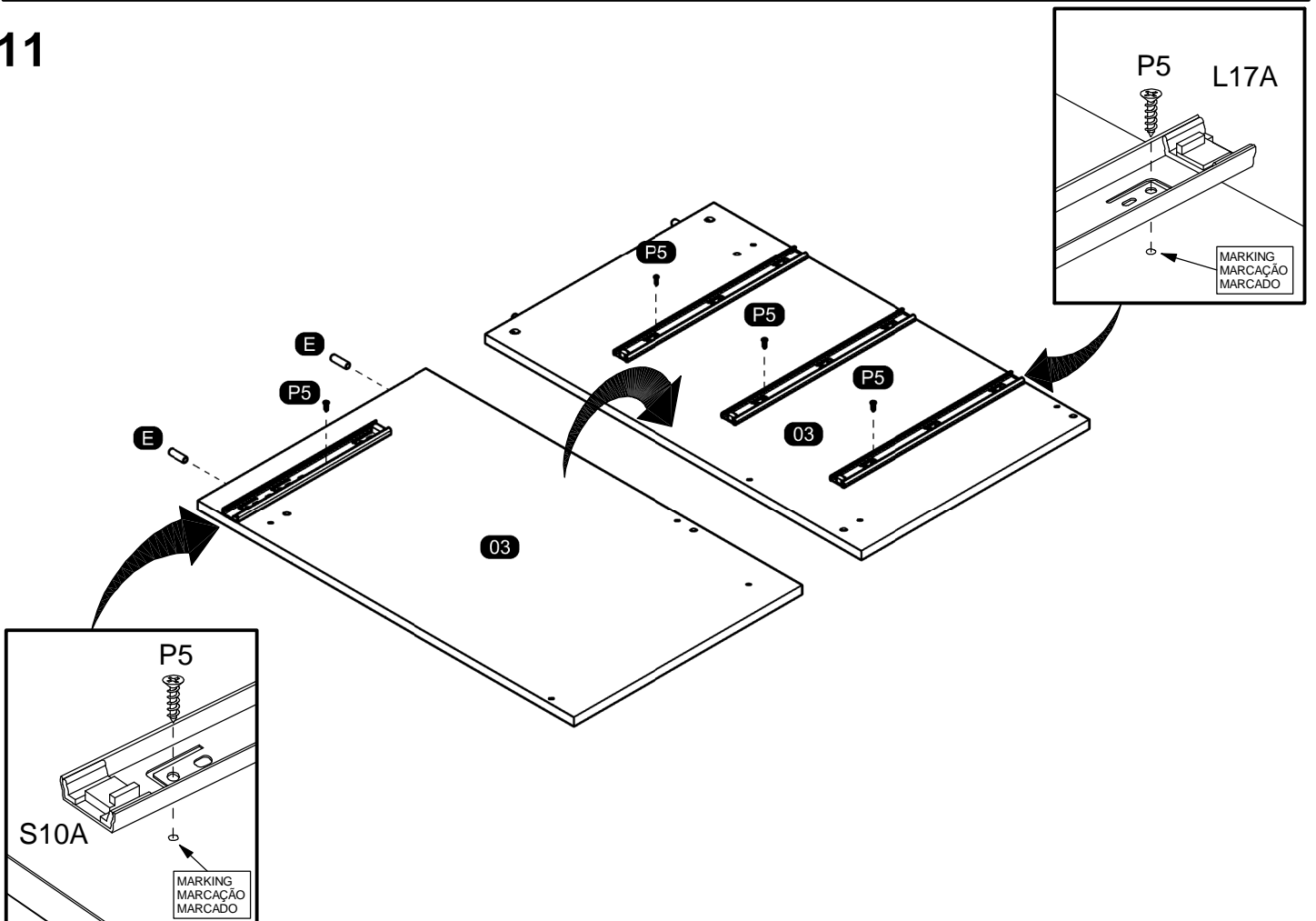

ASSEMBLY  
MONTAGEM / ARMADO

12

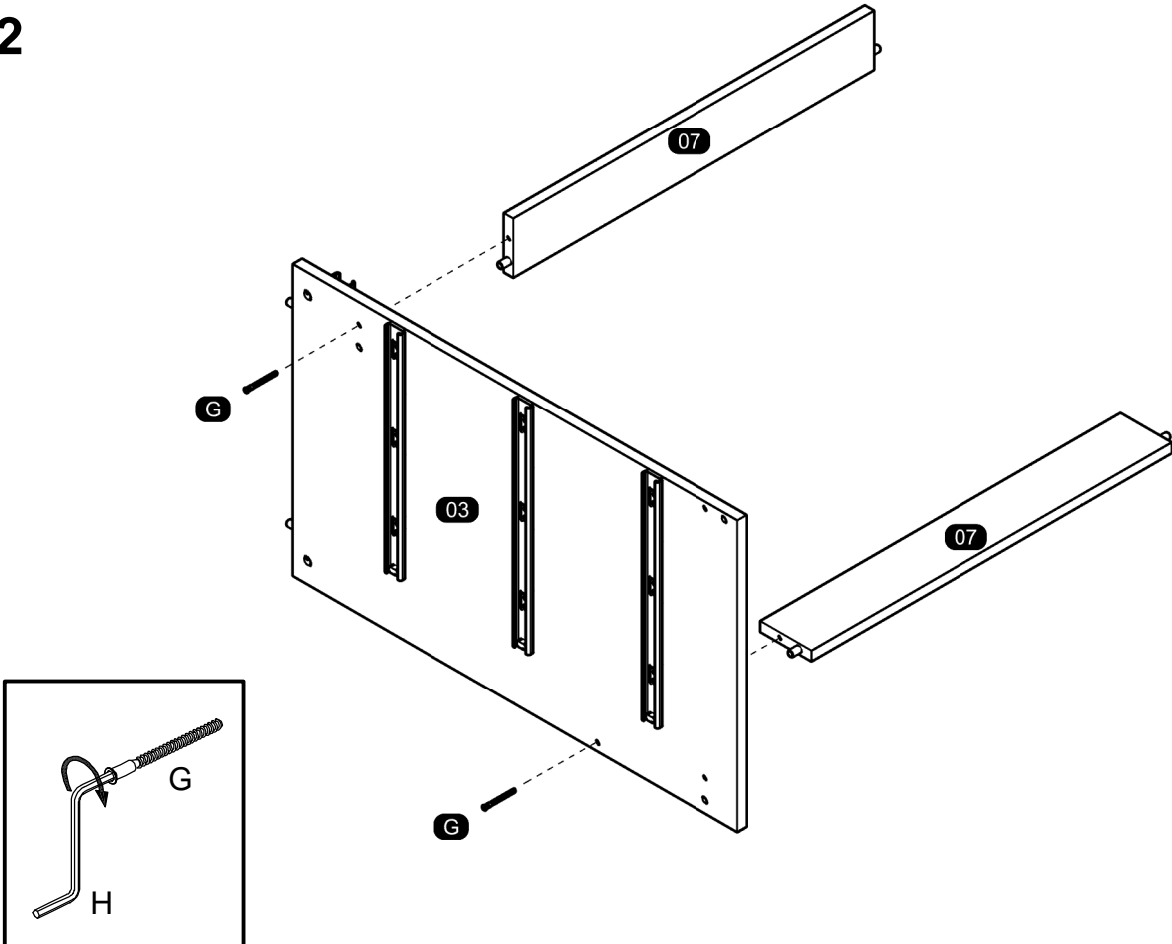

13

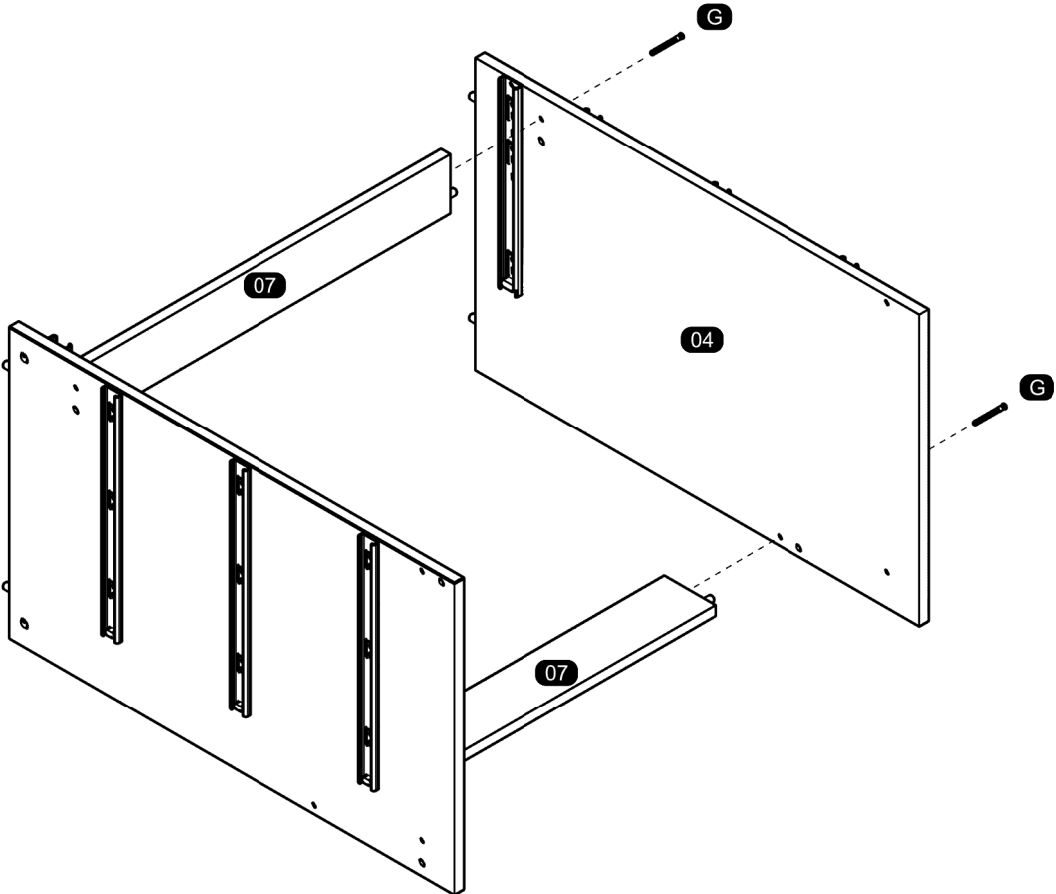



14

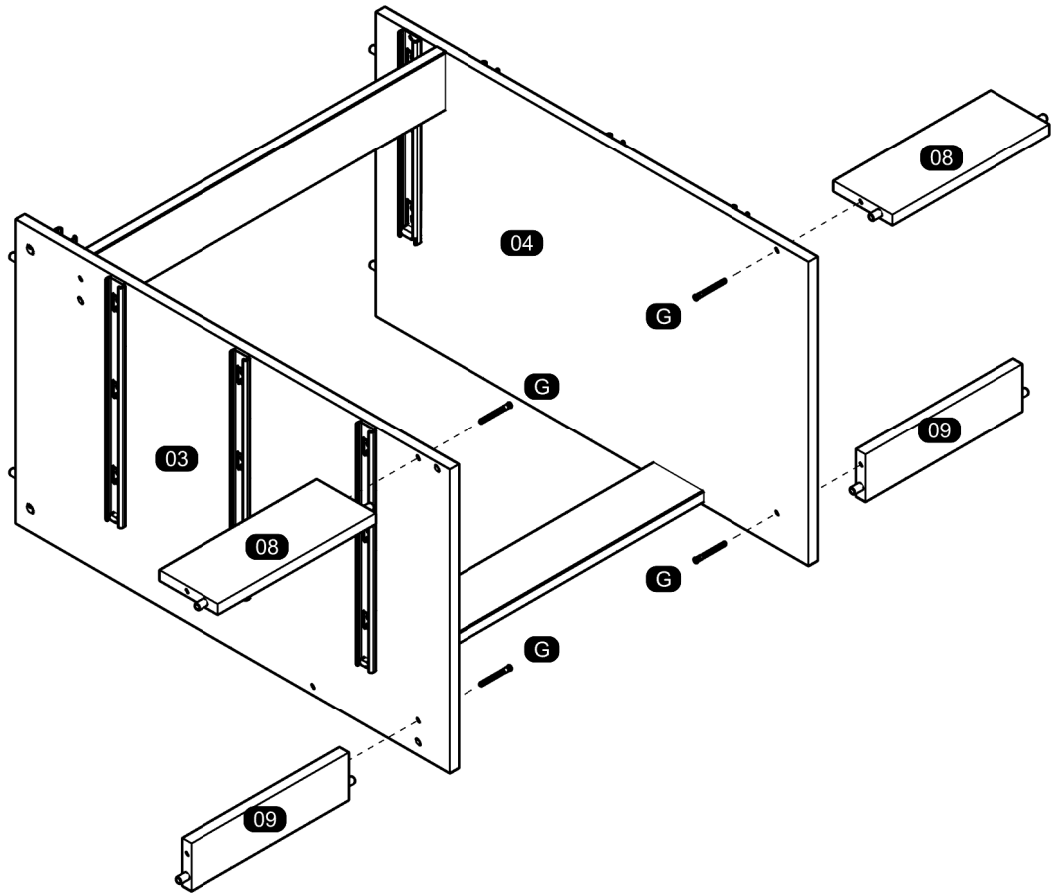

15

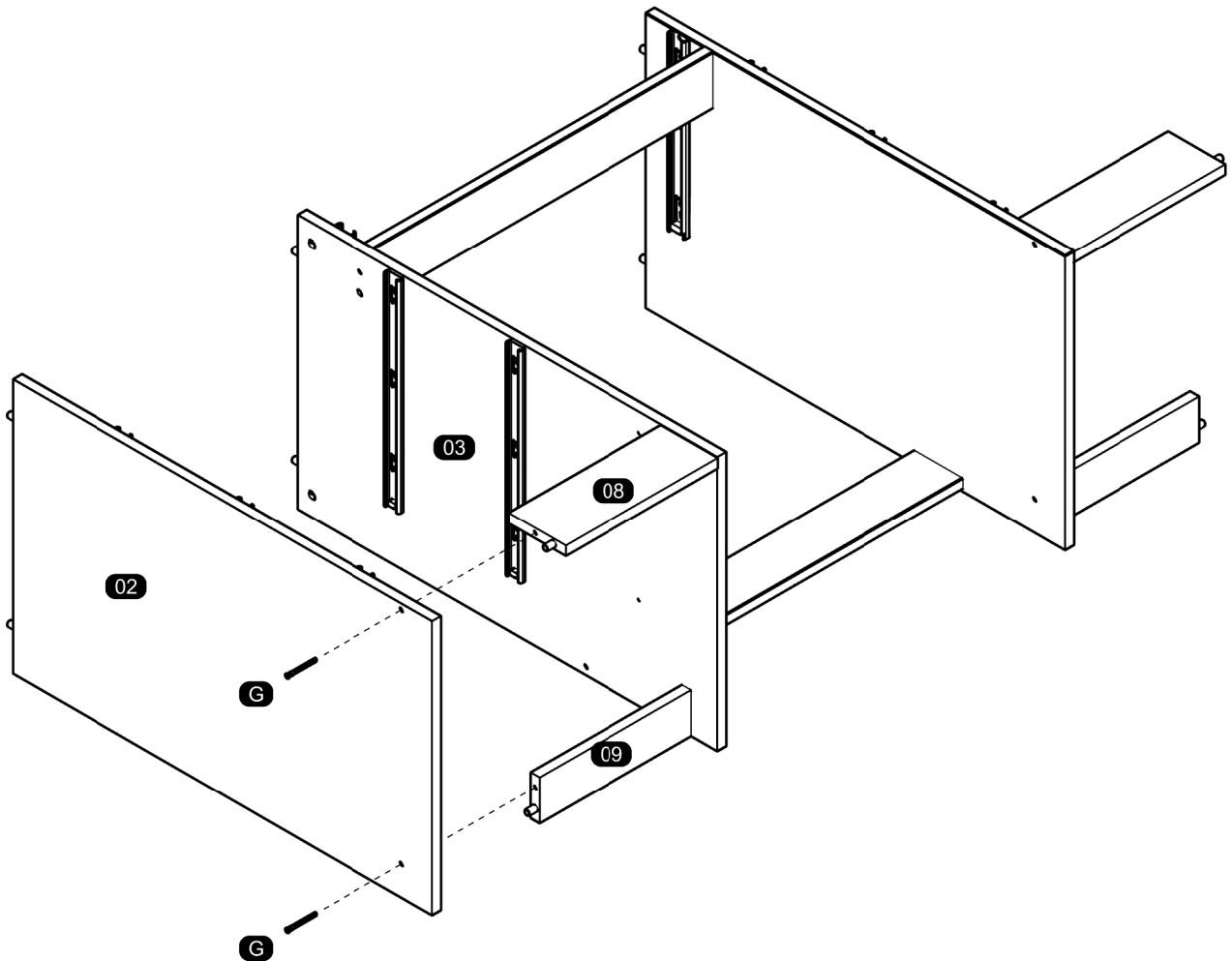

16

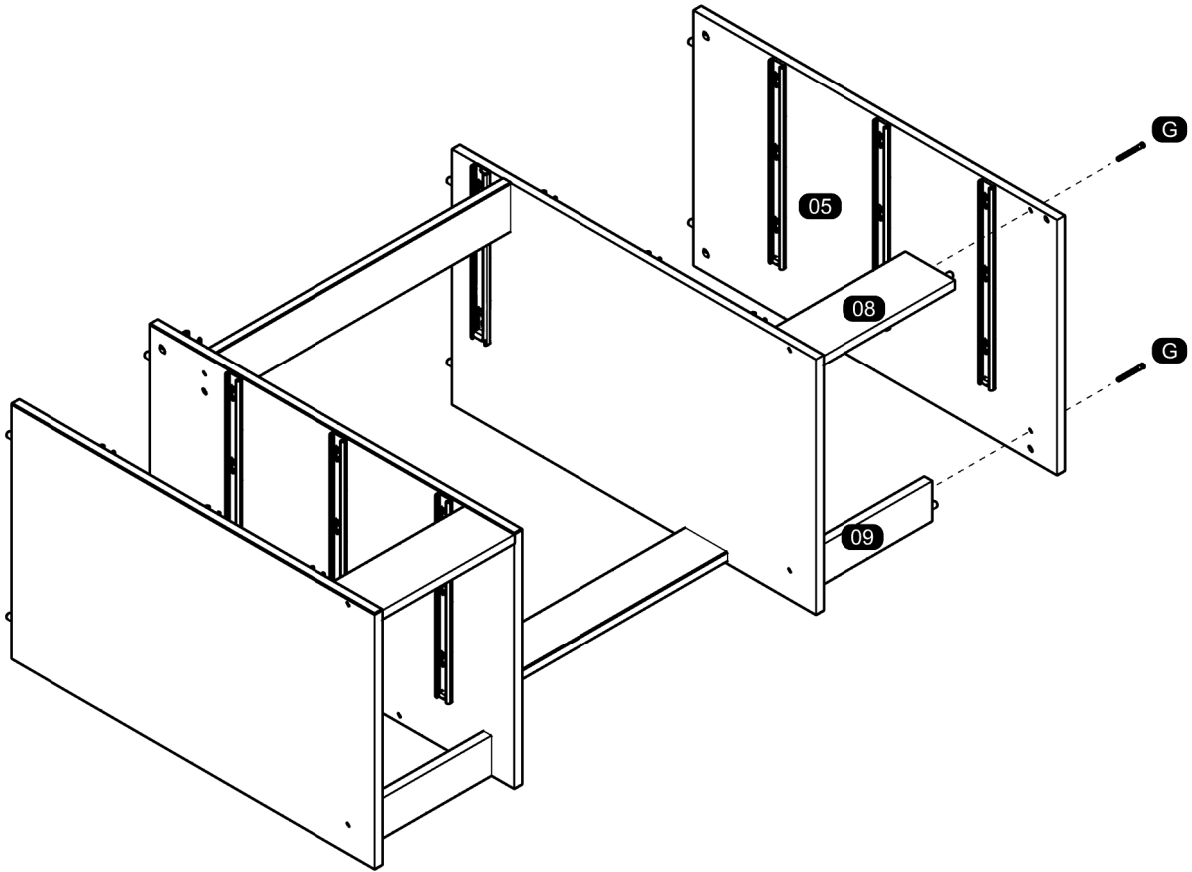

17

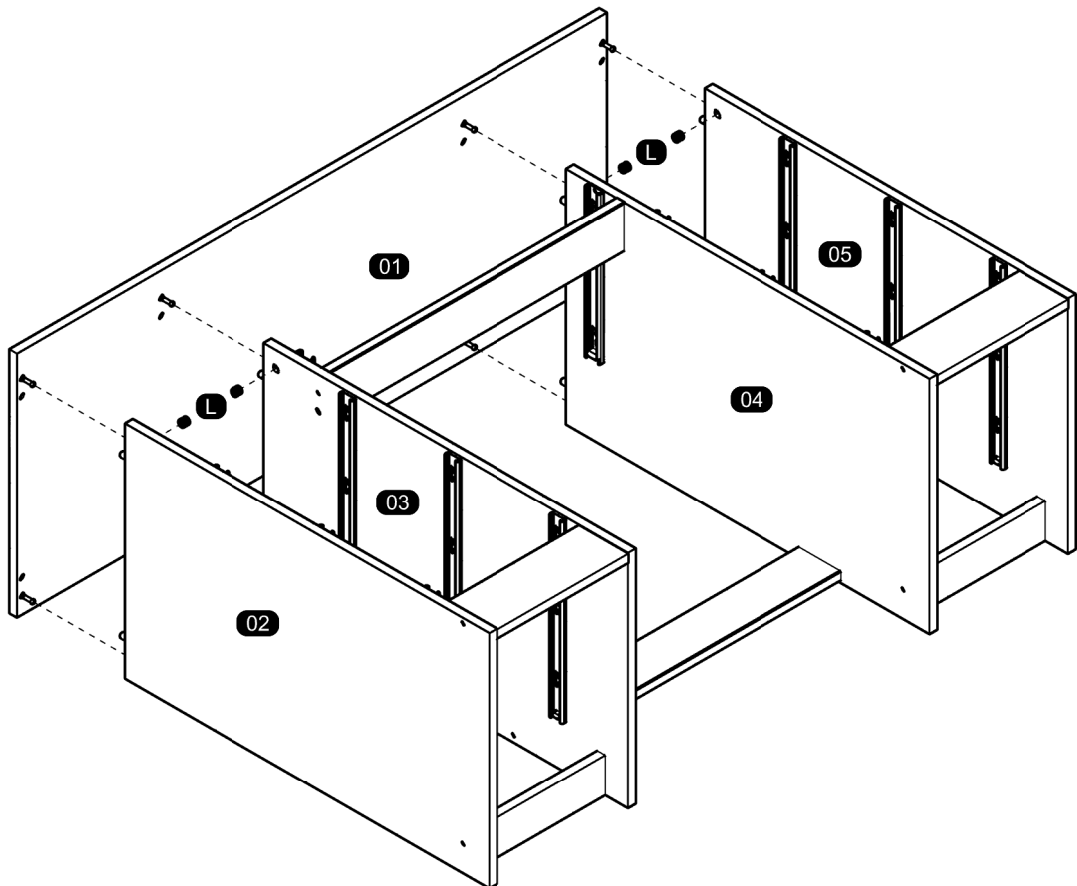

18

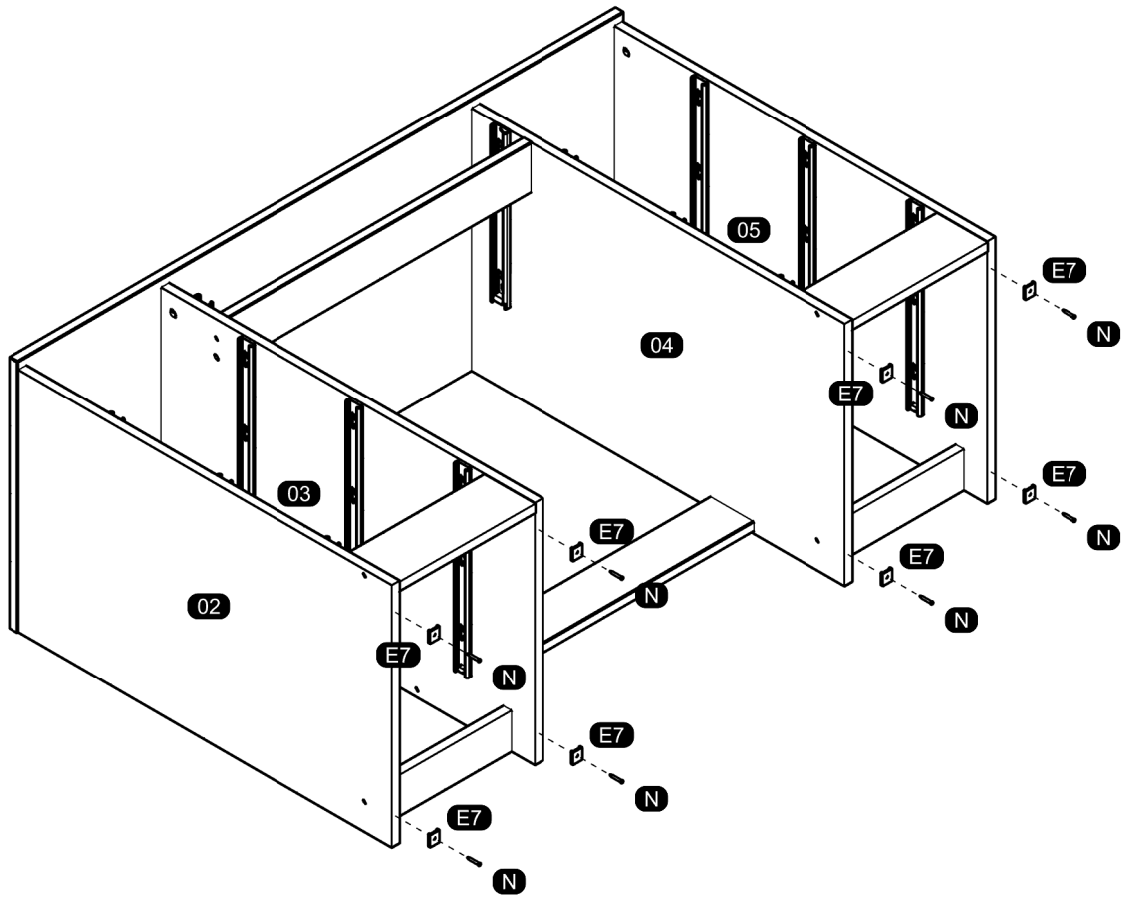

19

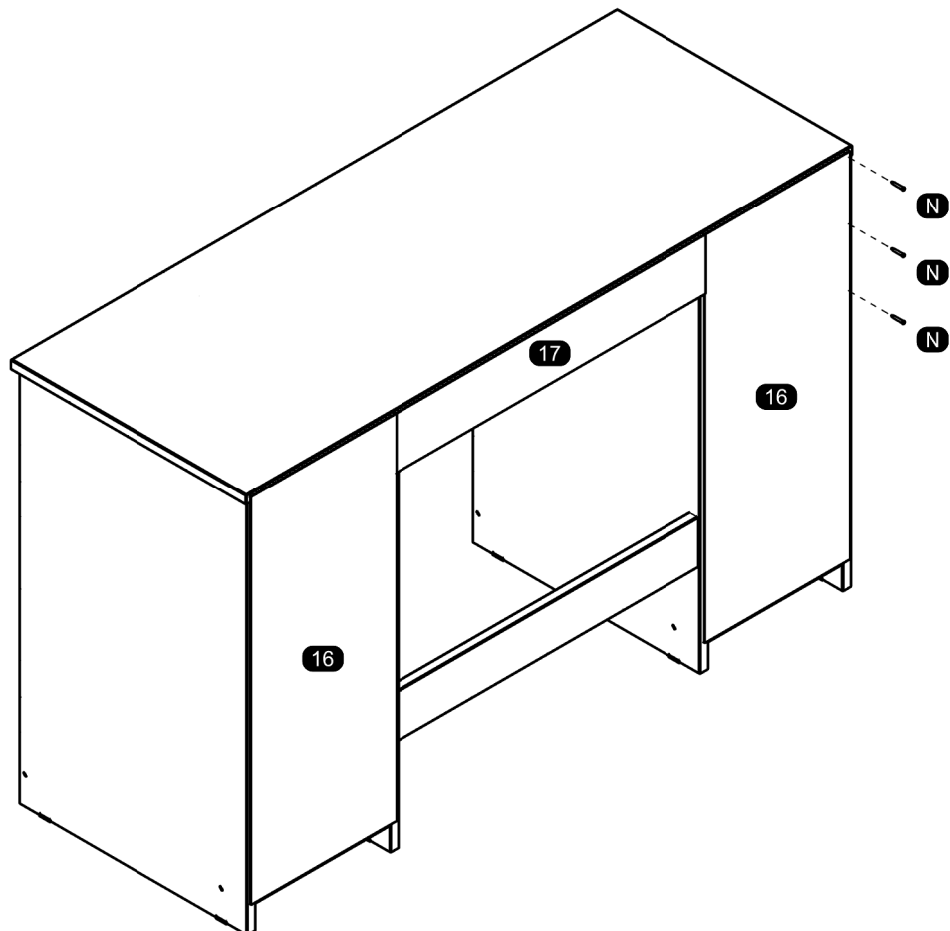
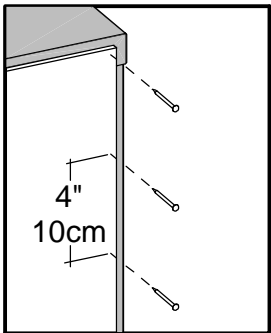

20

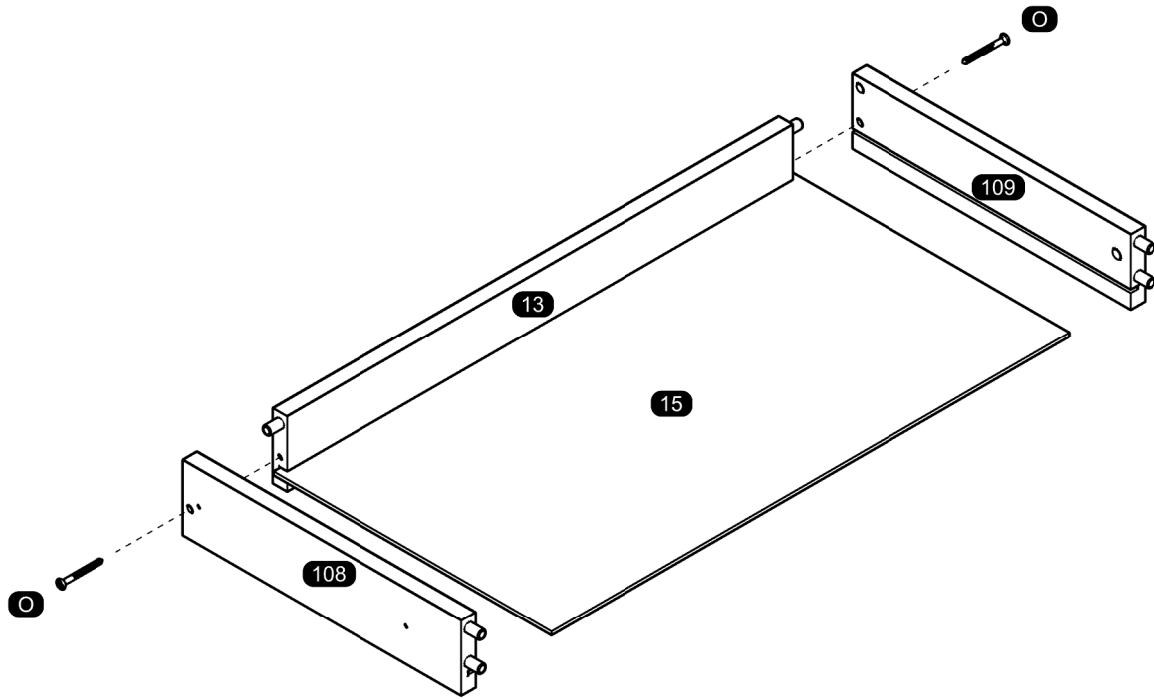

21

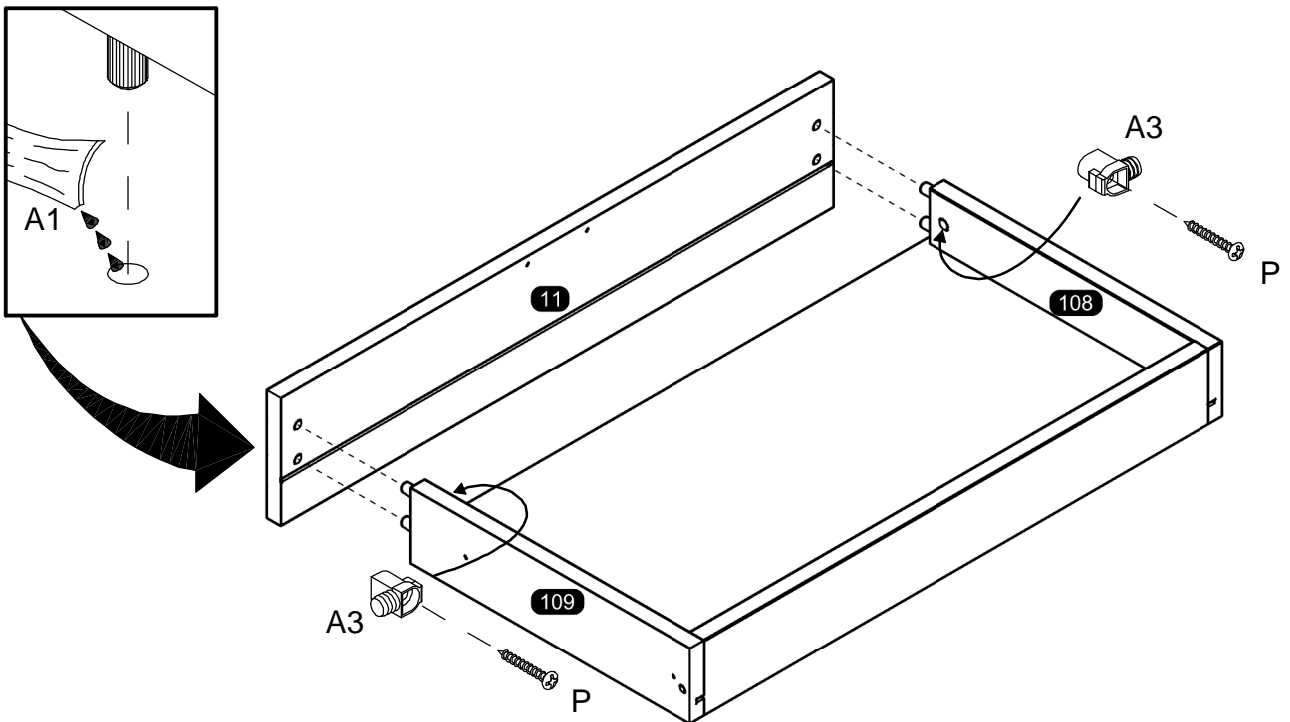

22

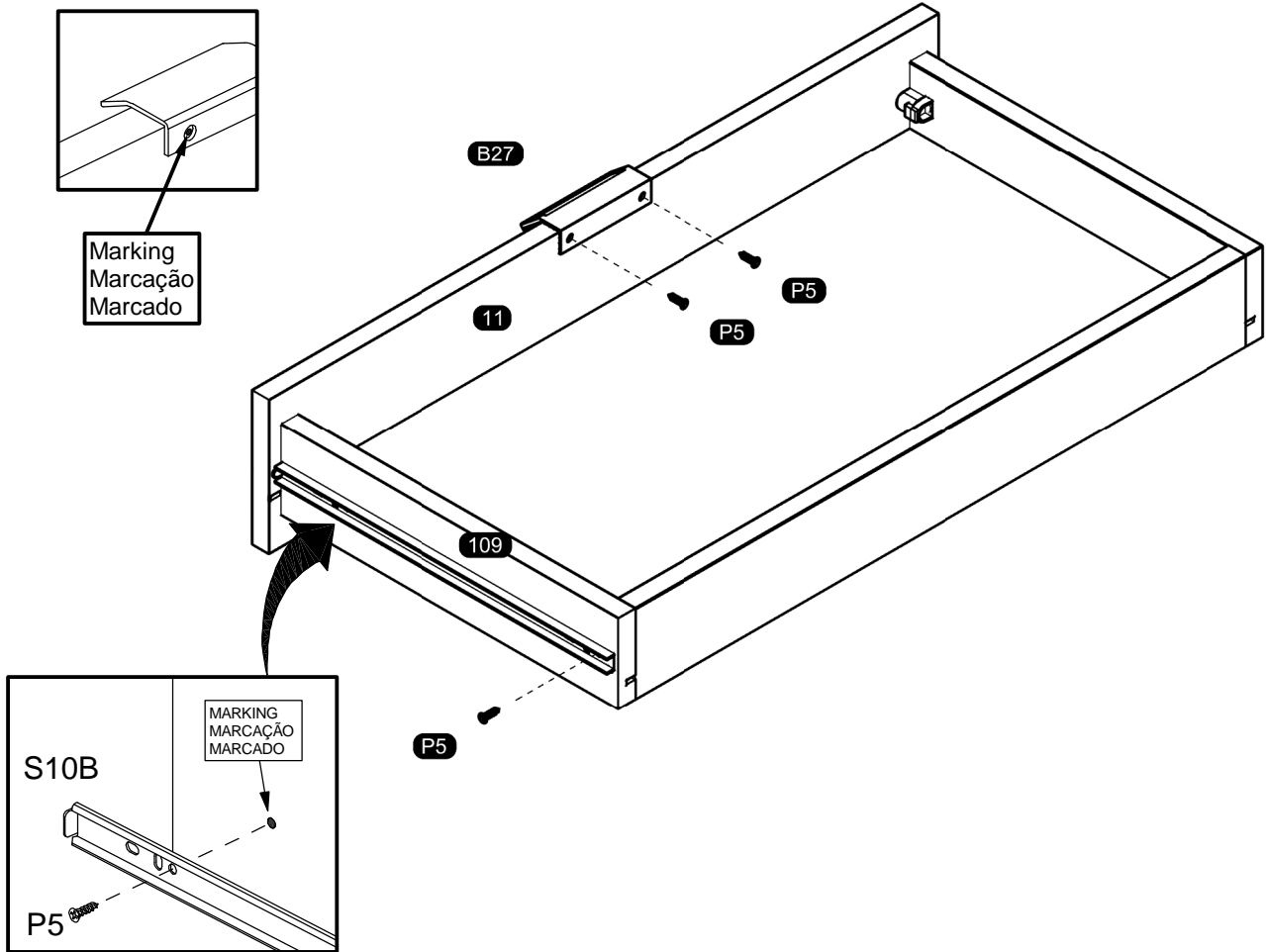

23

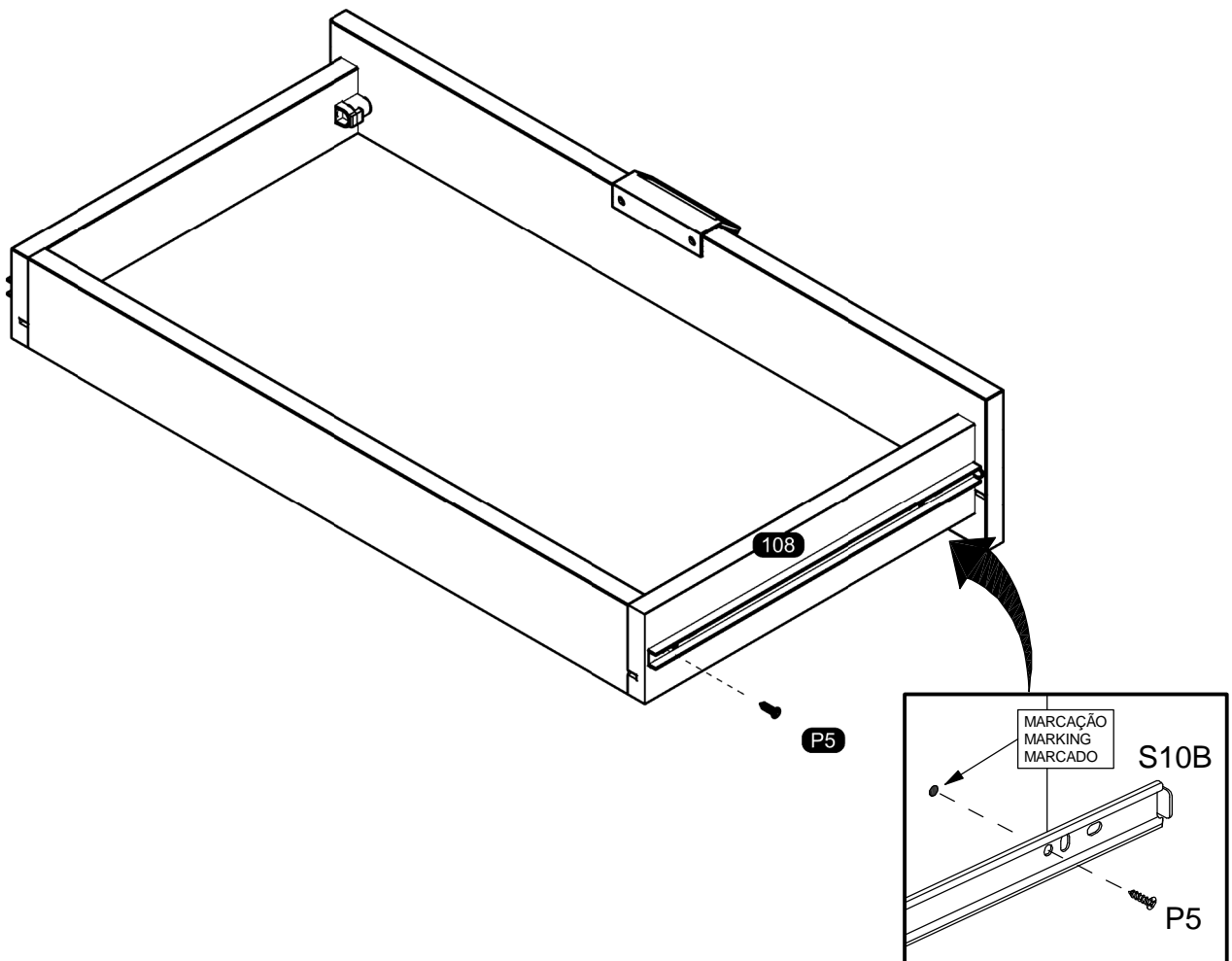

24

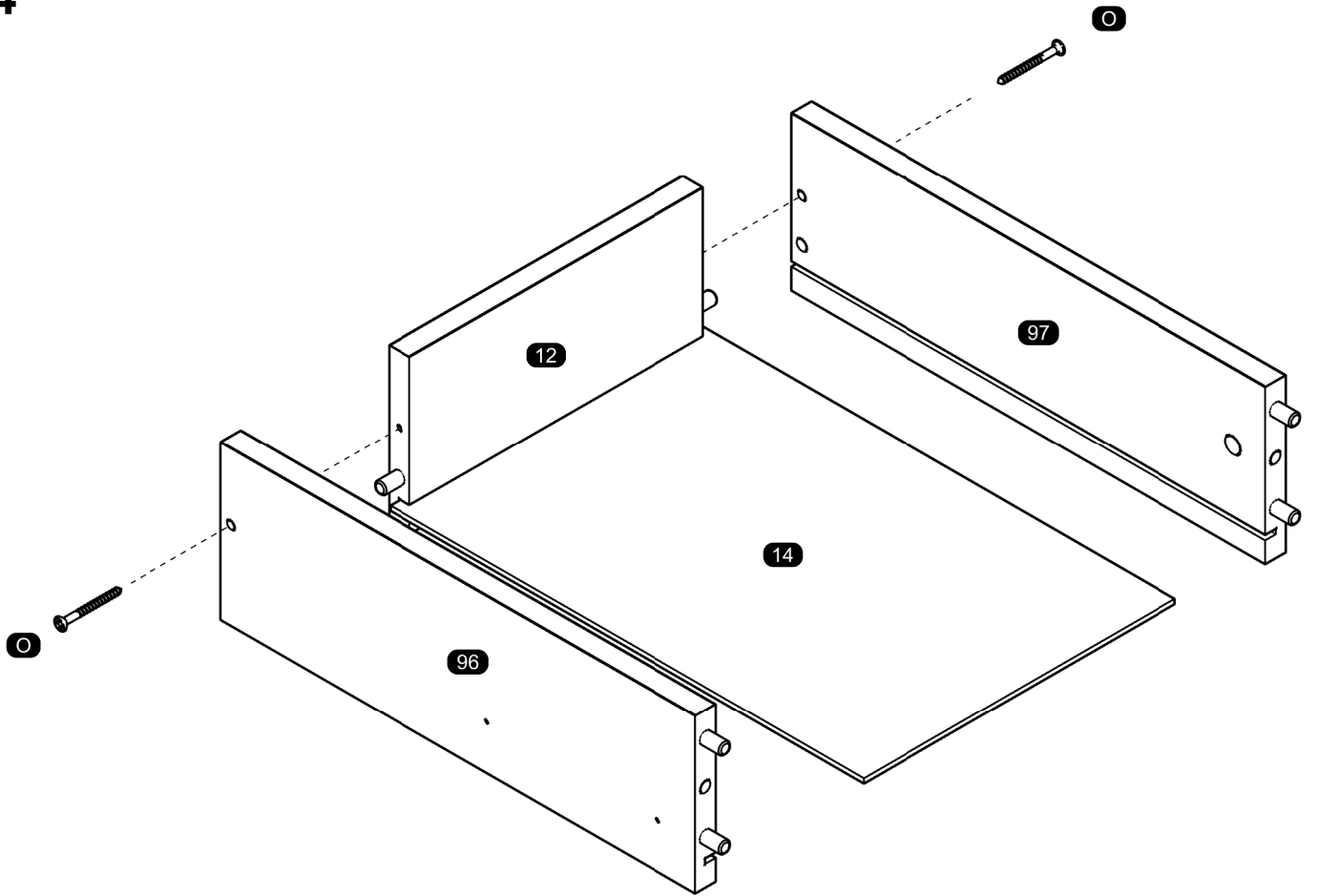

25

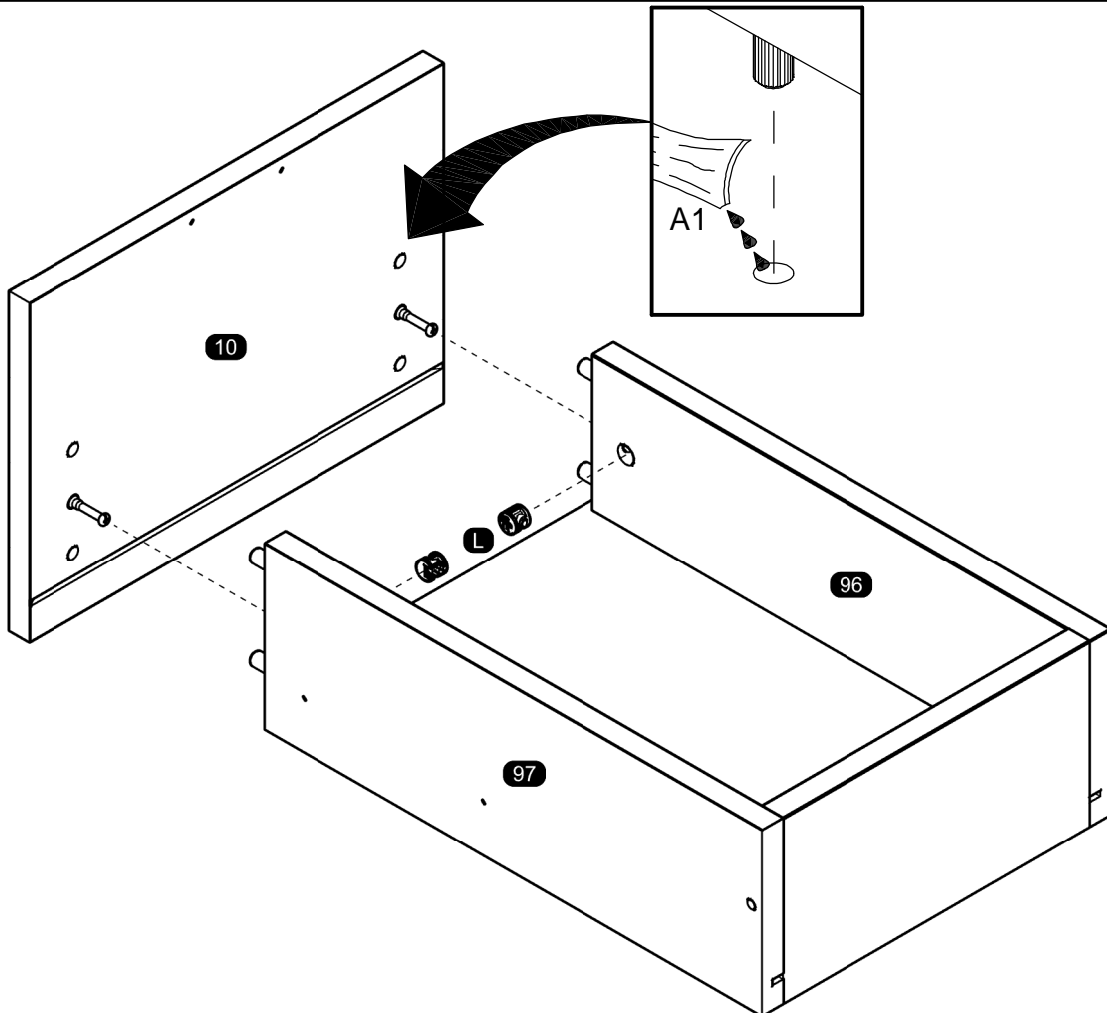

26

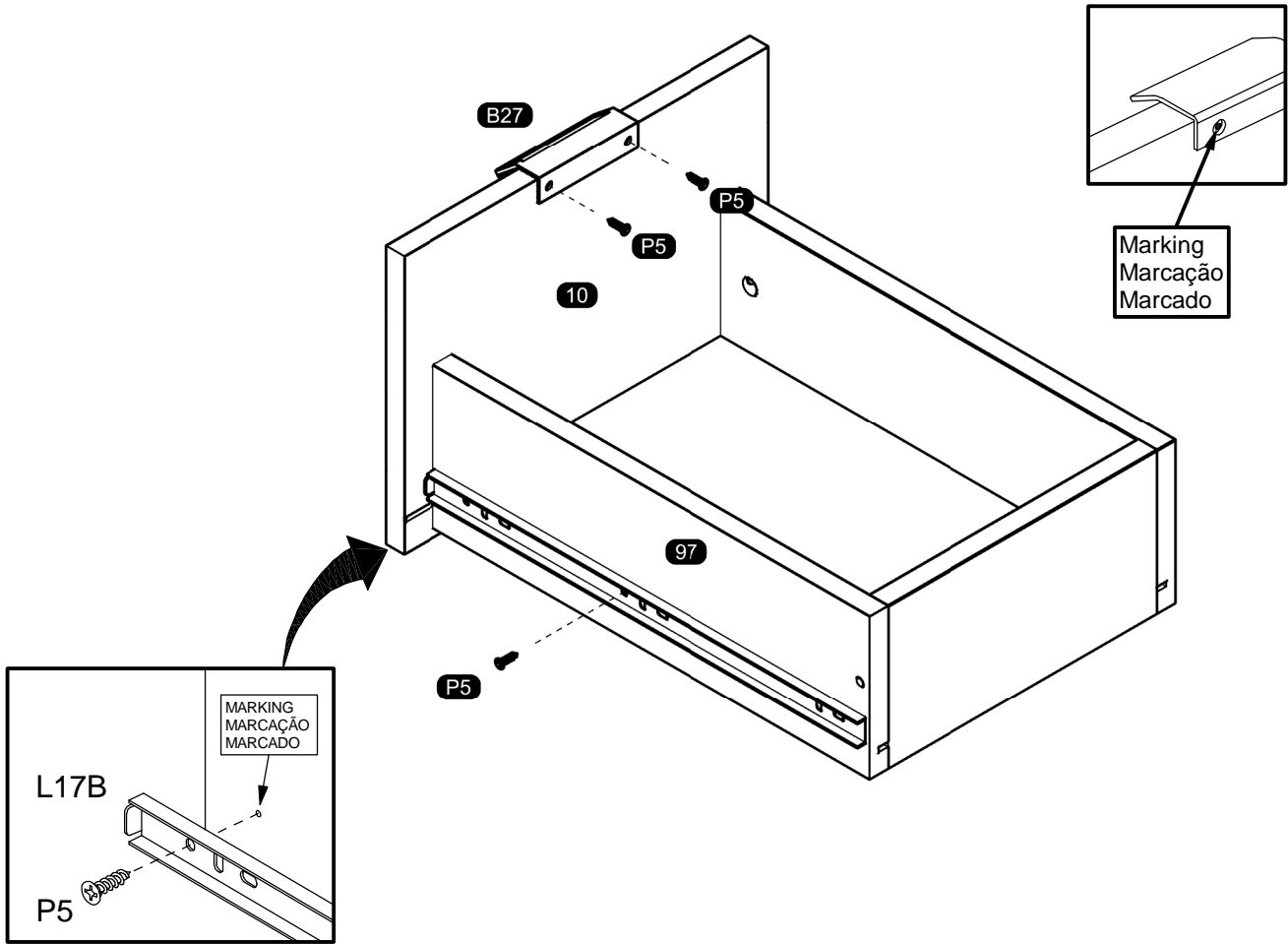

27

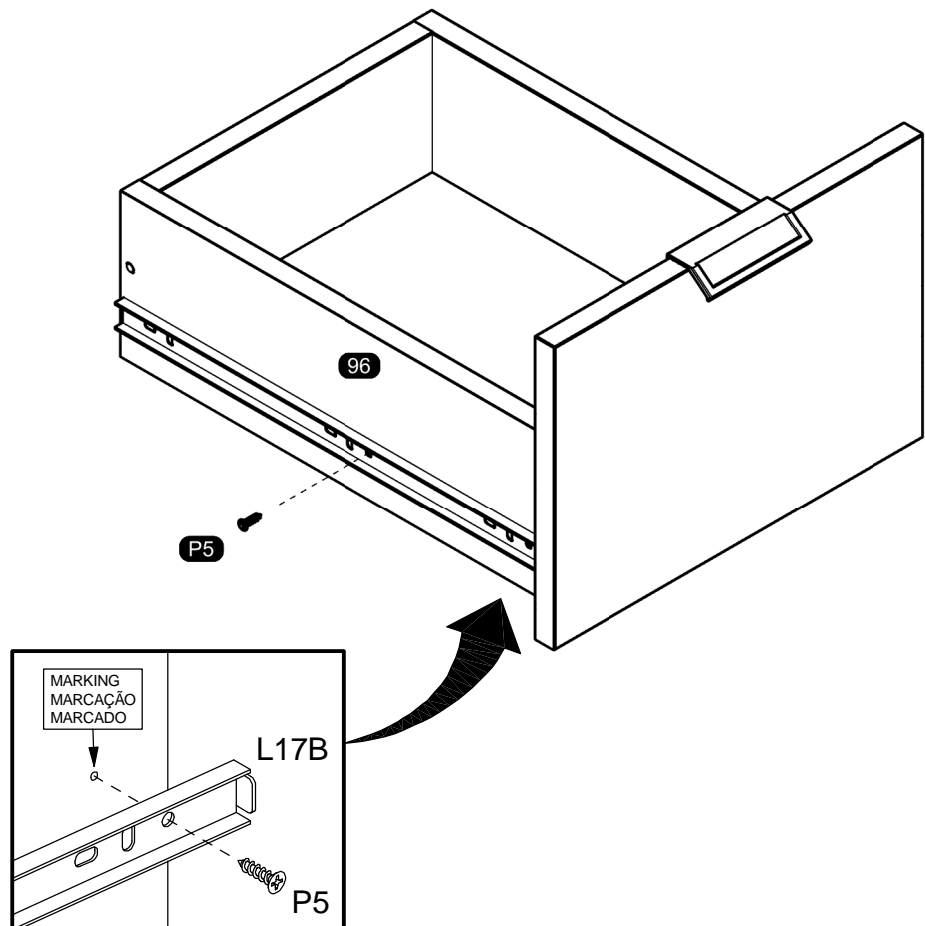

28

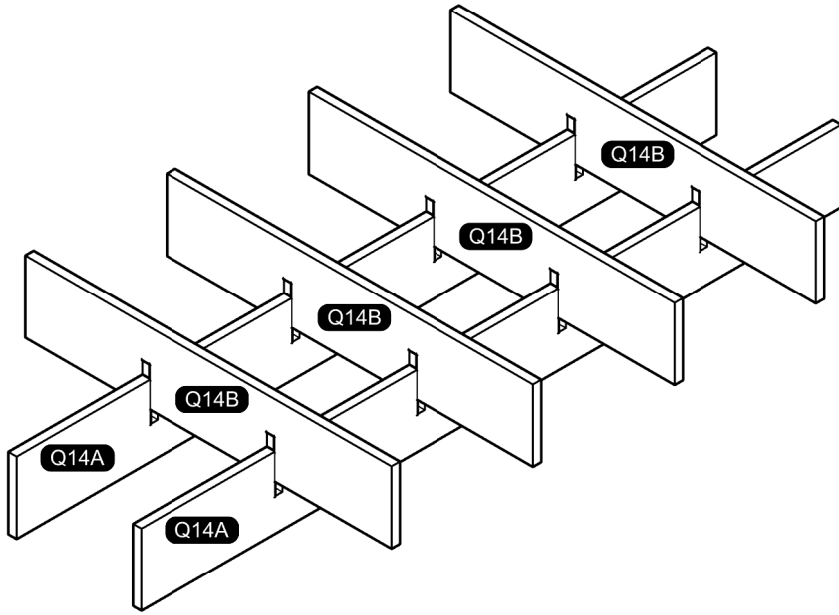

29

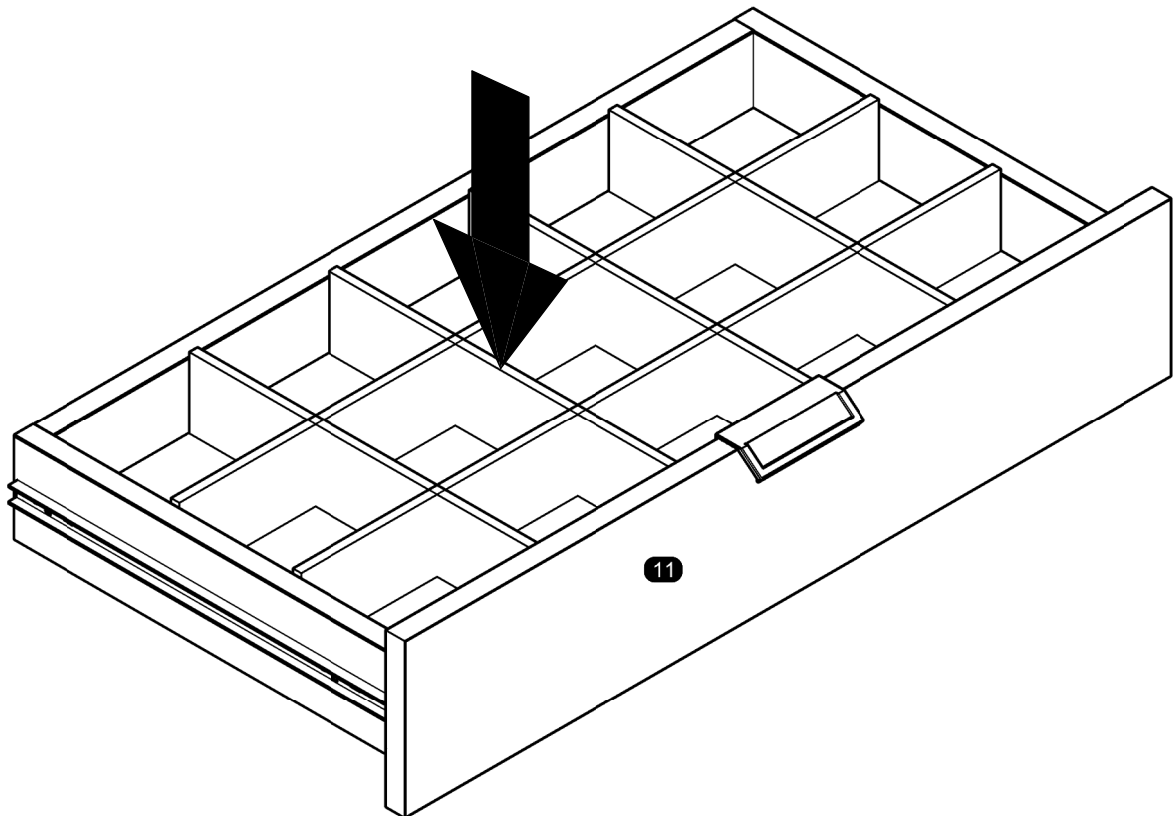



30

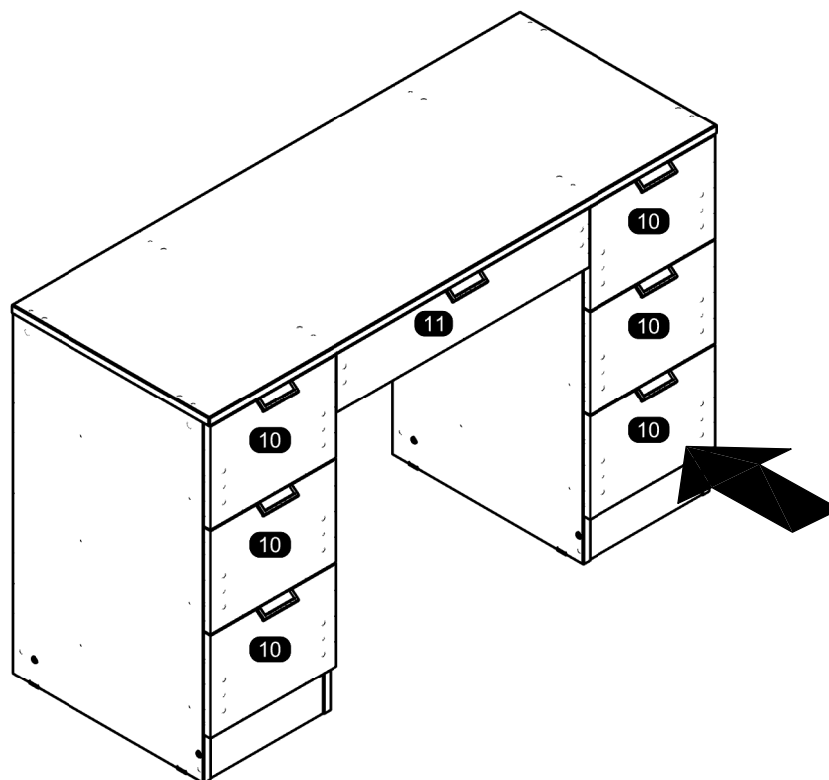

31

At the end of the assembly, insert the screw cover / hole plugs in the apparent holes.  
Ao final da montagem, insira a(s) tampa(s) de parafuso / tampa furos nos furos que ficarem aparentes.  
Al final del conjunto, coloque la tapa tornillo / tapón plástico en los agujeros que se hagan evidentes.

