

ASSEMBLY INSTRUCTIONS MANUAL DE MONTAGEM / INSTRUCCIONES DE ARMADO

COLUMBUS OFFICE TABLE

MESA COLUMBUS

ESCRITORIO COLUMBUS

Reference
Referência
Referencia

230164

Revised
Revisão
Revisión

00



ENGLISH
PORTUGUÊS
ESPAÑOL

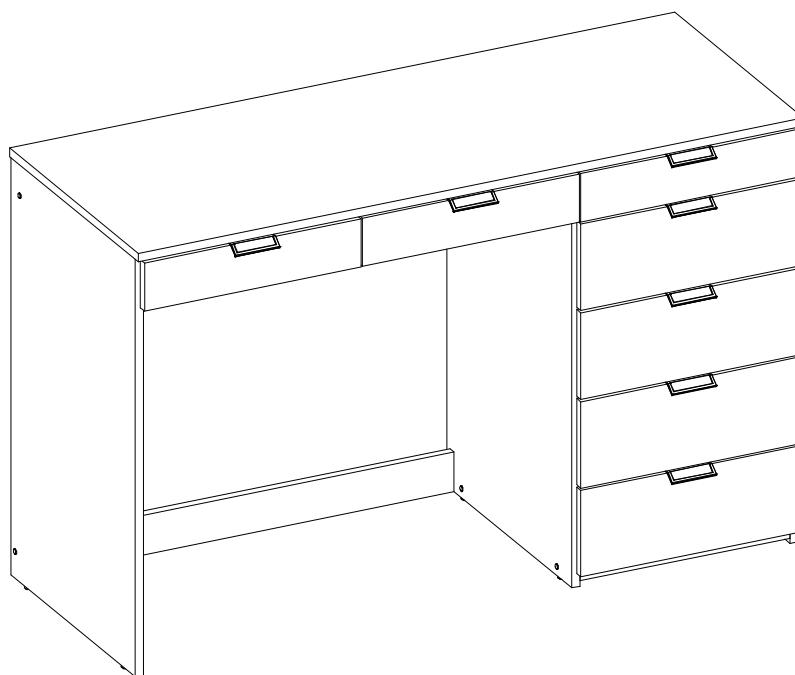

MAXIMUM RECOMMENDED WEIGHT
BEING THIS EVENLY DISTRIBUTED.

PESO MÁXIMO RECOMENDADO SENDO
ESTE DISTRIBUÍDO UNIFORMEMENTE.

PESO MÁXIMO RECOMENDADO SIENDO
ESTE UNIFORMEMENTE DISTRIBUIDO.

	LB	KG
–		
C	6	3
D	11	5
F	22	10

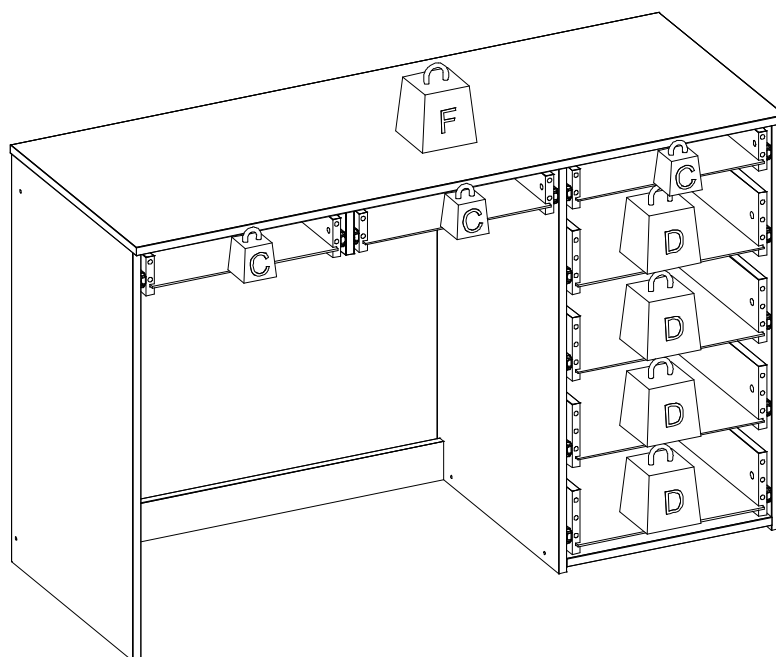

Nº	Measures_Inches	Medidas_cm	Qty./Qtd.
01	47 1/4 x 18 1/4 x 5/8	120.0 x 46.5 x 1.5	1
02	30 3/8 x 3 3/8 x 5/8	77.3 x 8.5 x 1.5	1
03	30 3/8 x 2 3/4 x 5/8	77.3 x 7.0 x 1.5	1
04	14 7/8 x 2 3/4 x 5/8	37.9 x 7.0 x 1.5	2
05	29 1/8 x 17 3/4 x 5/8	74.0 x 45.0 x 1.5	1
06	29 1/8 x 17 3/4 x 5/8	74.0 x 45.0 x 1.5	1
07	16 1/8 x 3 1/4 x 5/8	40.9 x 8.4 x 1.5	1
08	29 1/8 x 17 3/4 x 5/8	74.0 x 45.0 x 1.5	1
09	15 3/8 x 3 3/8 x 5/8	39.1 x 8.5 x 1.5	3
10	15 3/8 x 6 x 5/8	39.1 x 15.3 x 1.5	4
11	13 x 2 3/4 x 5/8	33.0 x 7.0 x 1.5	3
12	13 x 4 1/2 x 5/8	33.0 x 11.5 x 1.5	4
13	13 3/4 x 13 1/2 x 1/8	34.9 x 34.4 x 0.3	3
14	13 7/8 x 13 1/2 x 1/8	35.4 x 34.4 x 0.3	4
15	29 x 15 3/4 x 1/8	73.6 x 39.9 x 0.3	1
96	14 x 4 1/2 x 5/8	35.5 x 11.5 x 1.5	4
97	14 x 4 1/2 x 5/8	35.5 x 11.5 x 1.5	4
112	13 3/4 x 2 3/4 x 5/8	35.0 x 7.0 x 1.5	3
113	13 3/4 x 2 3/4 x 5/8	35.0 x 7.0 x 1.5	3

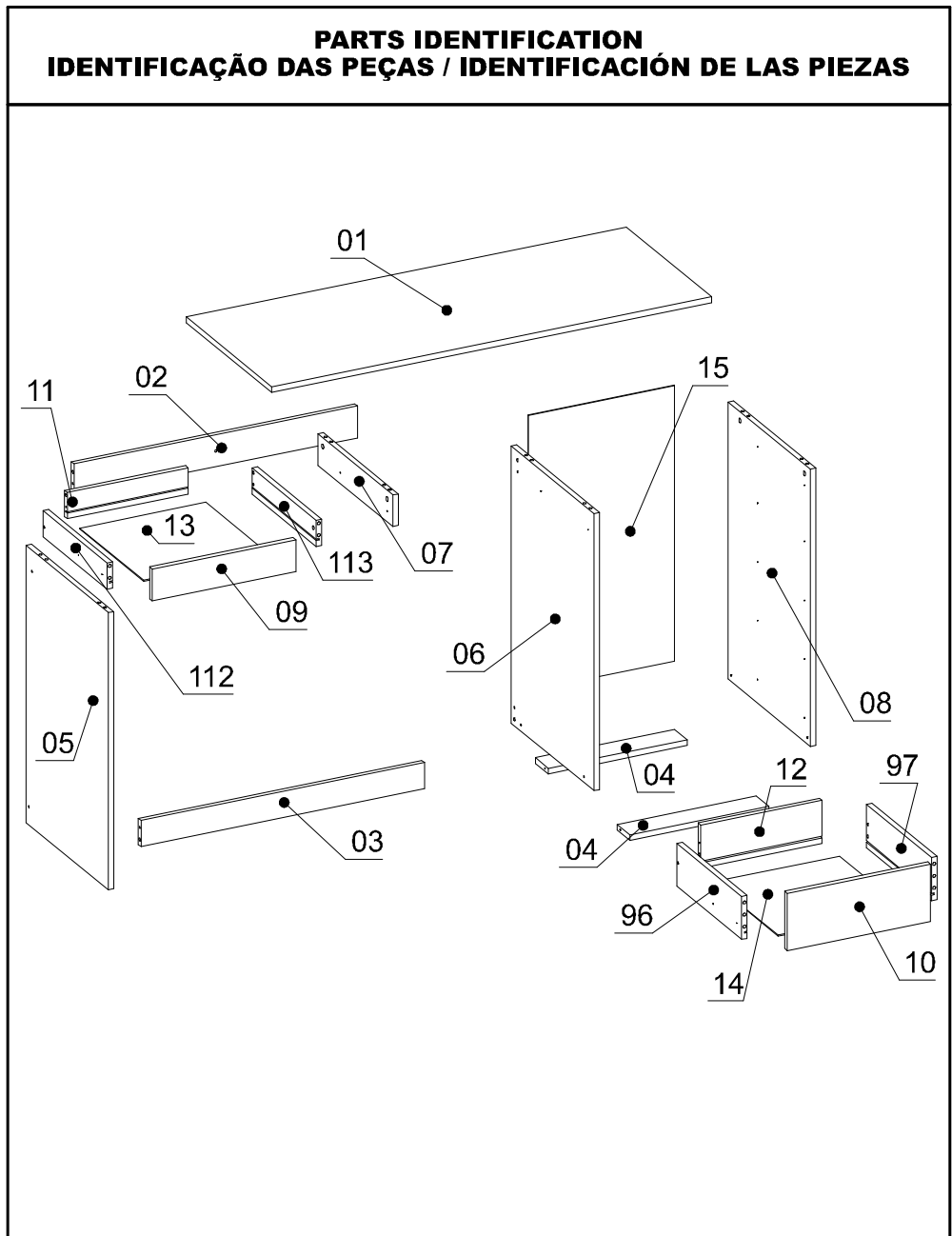

YOU WILL NEED / VOCÊ VAI PRECISAR DE / USTED NECESITARÁ

Tools not supplied / Ferramentas não fornecidas / Herramientas no incluidas

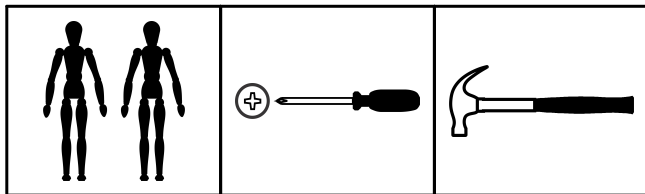

2 People
2 Pessoas
2 Personas

Screwdriver Phillips
Chave Phillips
Destornillador cruz

Hammer
Martelo
Martillo











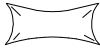

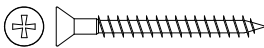

The separation of the accessories before you start the assembly will facilitate the same. In case of doubt on the size of the screws and bolts, use the ruler to bottom of page 3.

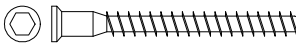
A separação dos acessórios antes de iniciar a montagem facilitará a mesma. Em caso de dúvida no tamanho dos parafusos e cavilhas, utilize a régua ao final da página 3.

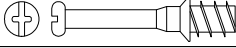
La separación de los accesorios antes de comenzar el armado facilitará el mismo. En caso de duda sobre el tamaño de los tornillos y taquetes, utilice la regla al pie de página 3.

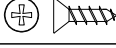
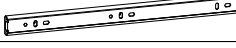
IDENTIFICATION OF ACCESSORIES IDENTIFICAÇÃO DOS ACESSÓRIOS/ IDENTIFICACIÓN DE ACCESORIOS

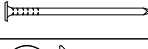
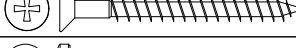
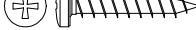
A1		Glue / Cola / Pegamento	13 g	1
A2		Small plastic foot / Sapata redonda / Pie plástico	14 mm	6
A3		Trapeze / Trapézio / Trapecio	-	6
B27		Handle / Puxador Cristales / Tirador	64mm	7
D		Flat head screw / Parafuso chato / Tornillo de cabeza plana	4,0x40 mm	1
E		Wooden dowel / Cavilha / Taquete	8x30 mm	54
G		Structural screw / Parafuso estrutural / Tornillo estructural	5,0x50 mm	8
H		Allen key / Chave allen / Liave allen	3 mm	1
I		Structural screw cover/Tampa parafuso estrutural/Tapa tornillo estructural	-	6
J		Simple minifix screw / Haste minifix simples / Tornillo minifix simple	-	16
L		Drum lock / Tambor minifix / Tambor minifix	12 mm	16
L9		Flat head screw / Parafuso chato / Tornillo de cabeza plana	3,5x12 mm	70
L17		Telescopic slide / Corrediça telescópica / Corredera telescópica	350 mm	7
M		Bore patch adhesive / Tapa furo adesivo / Tapones adhesivo	-	8
N		Nail / Prego / Clavo	10x10	28
O		Flat head screw / Parafuso chato / Tornillo de cabeza plana	4,5x45 mm	14
P		Pan head screw / Parafuso panela / Tornillo de pan	4,5x25 mm	6



PRE-ASSEMBLE PRÉ-MONTAGEM / PRE ARMADO

01

SEPARATE THE TWO PARTS OF THE METAL SLIDE TO THE ASSEMBLY FOLLOWING THE INSTRUCTIONS BELOW.
SEPARARE AS DUAS PARTES DA CORREDEIRA METÁLICA PARA A MONTAGEM SEGUINDO AS INSTRUÇÕES ABAIXO.
SEPARAR LAS DOS PARTES DE LA CORREDEIRA DE METAL PARA EL ARMADO Y SEGUIR LAS INSTRUCCIONES ABAJO.

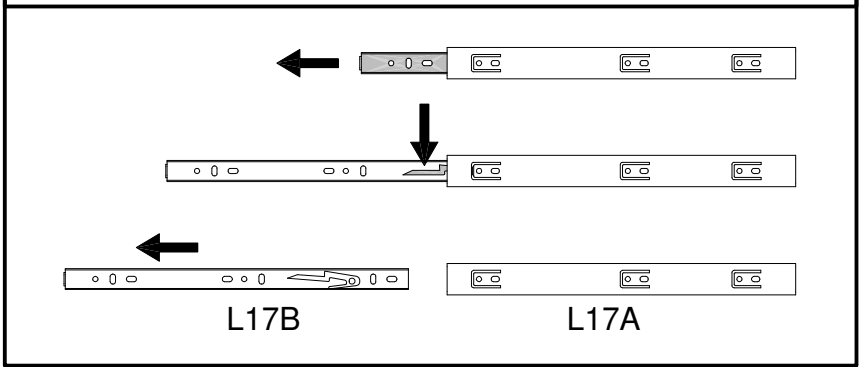

02

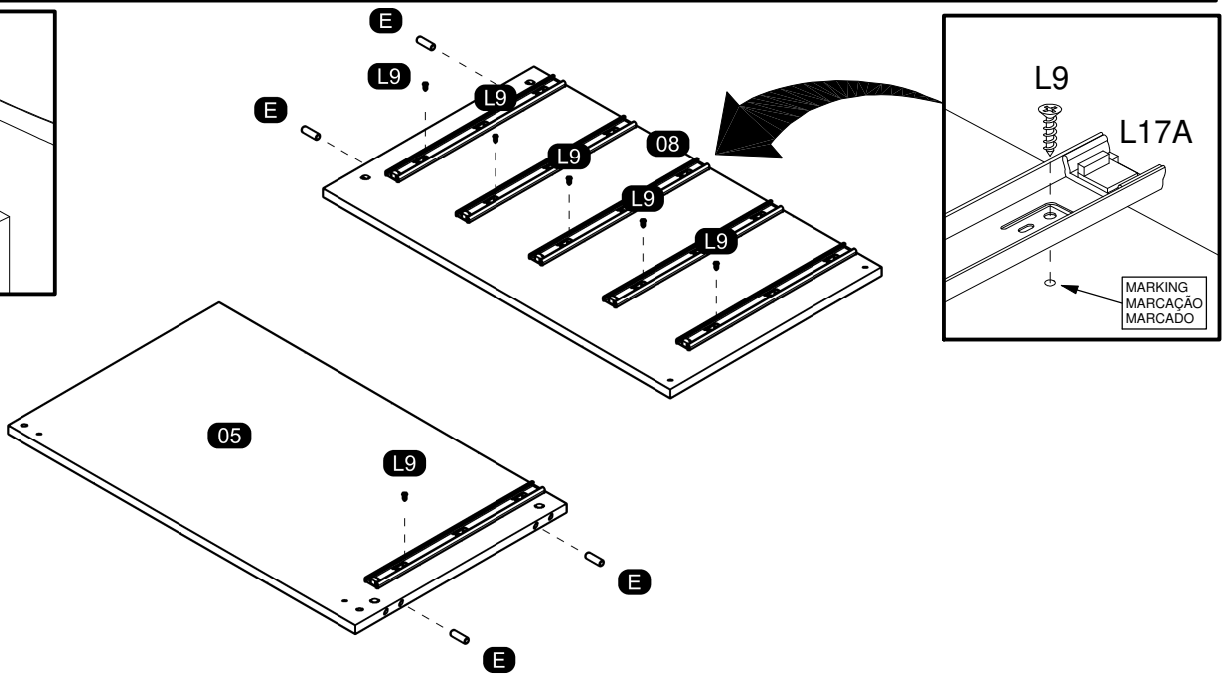
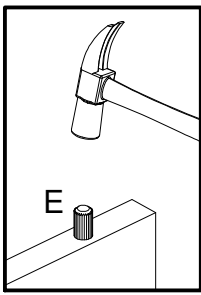

03

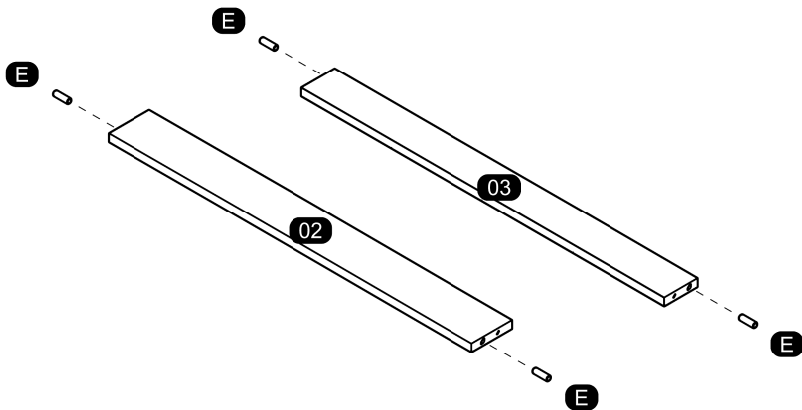

04

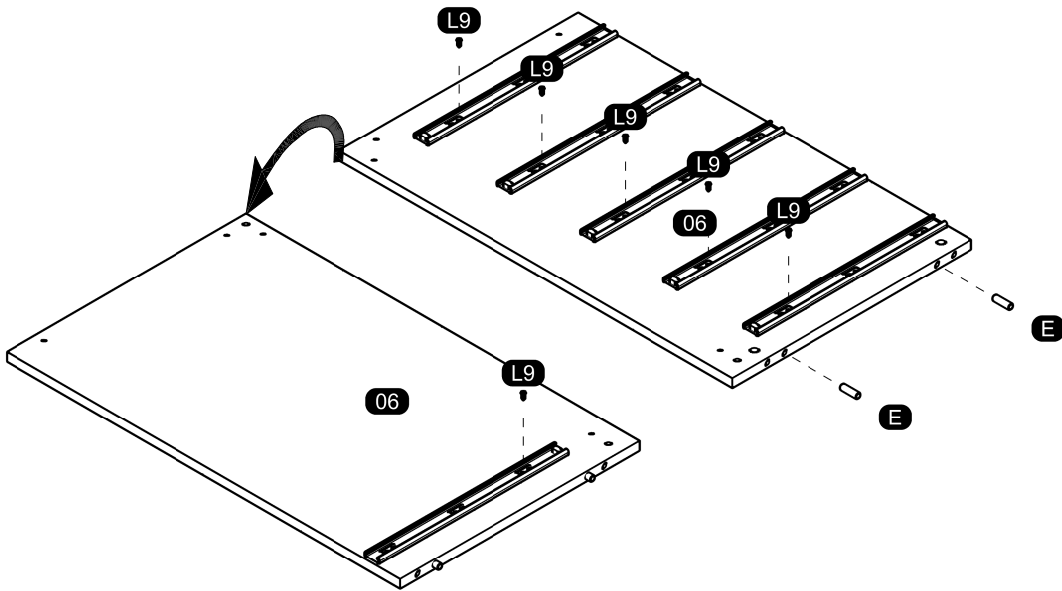

05

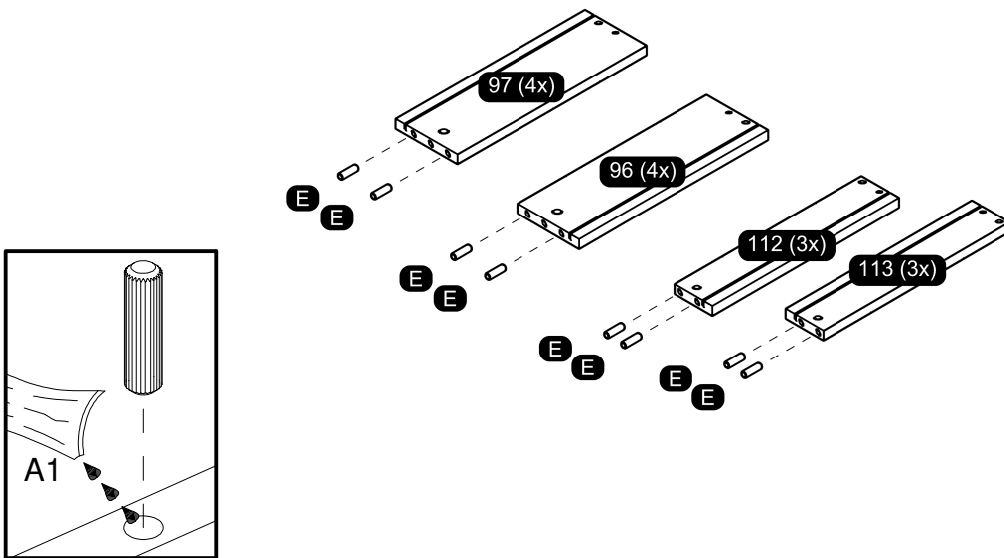

06

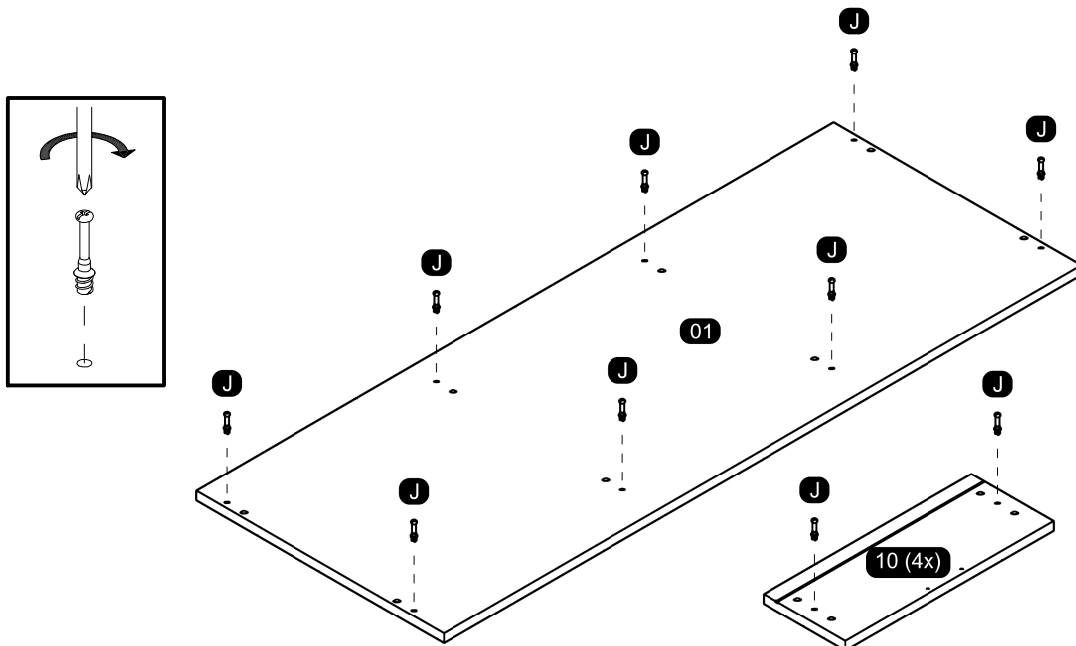

07

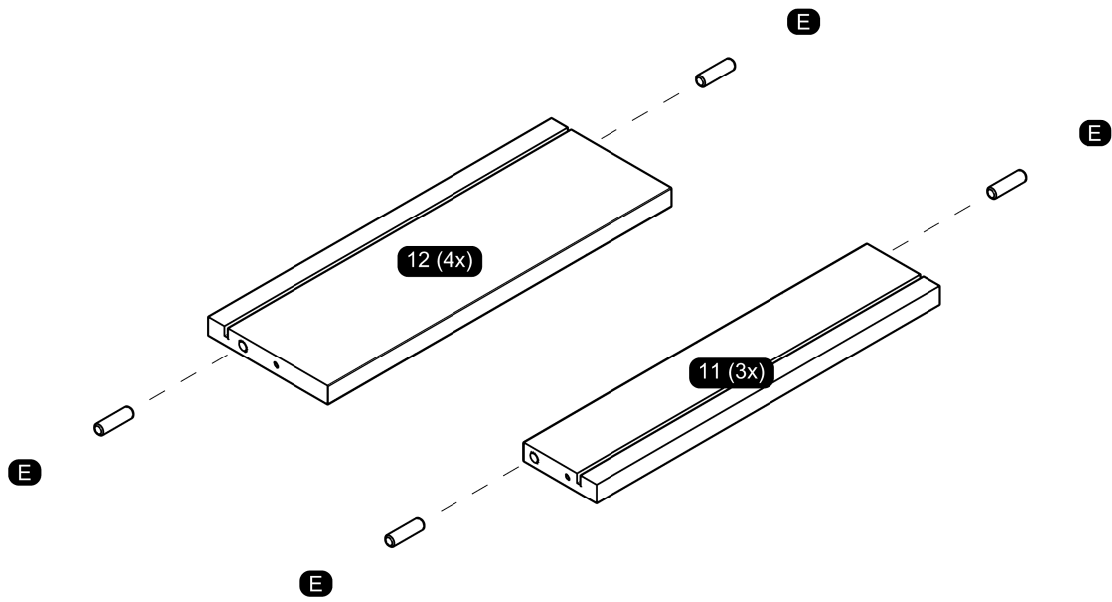

08

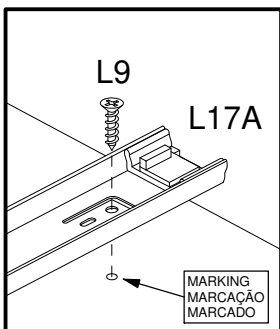
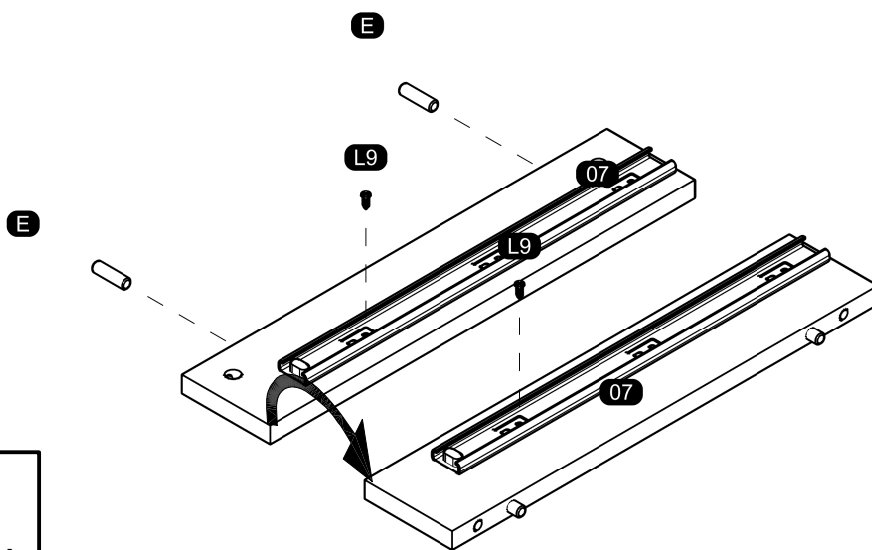

ASSEMBLY
MONTAGEM / ARMADO

09

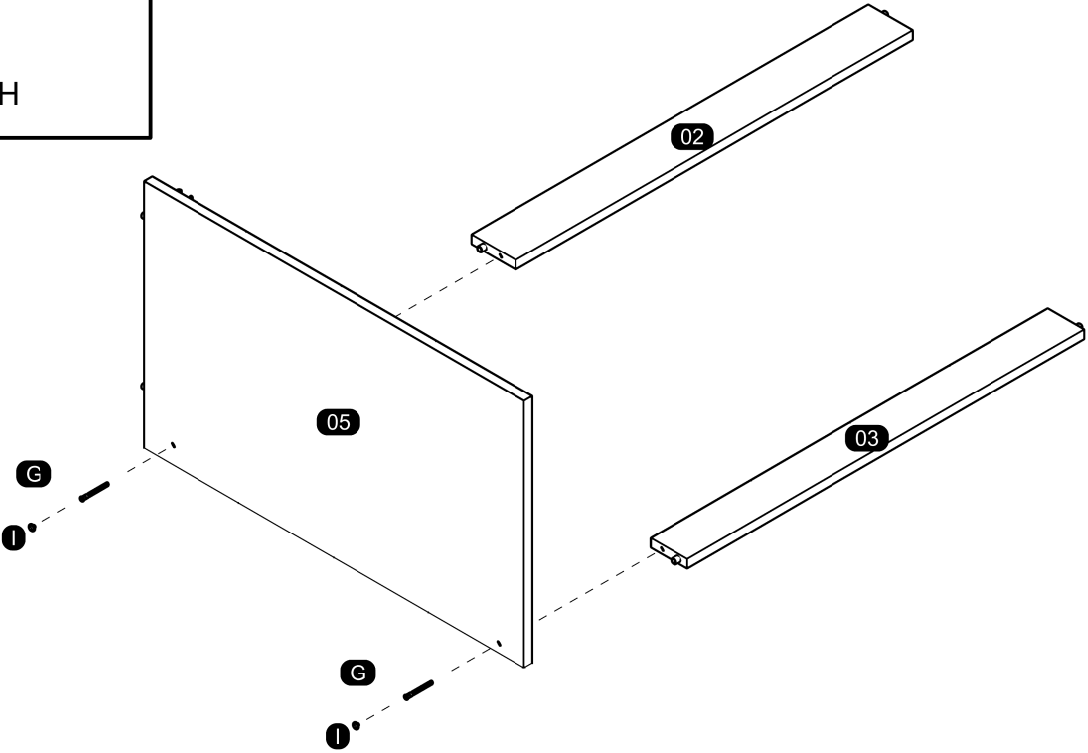
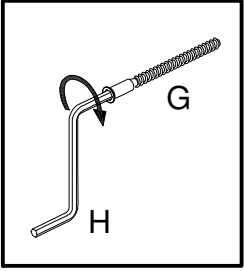

10

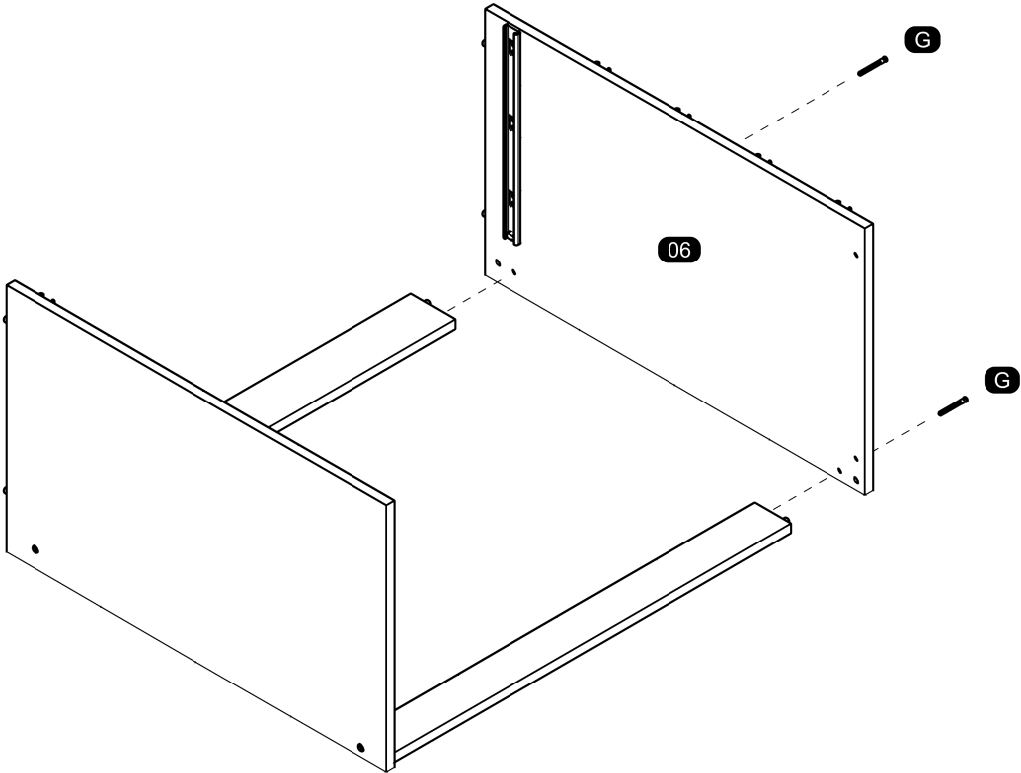

11

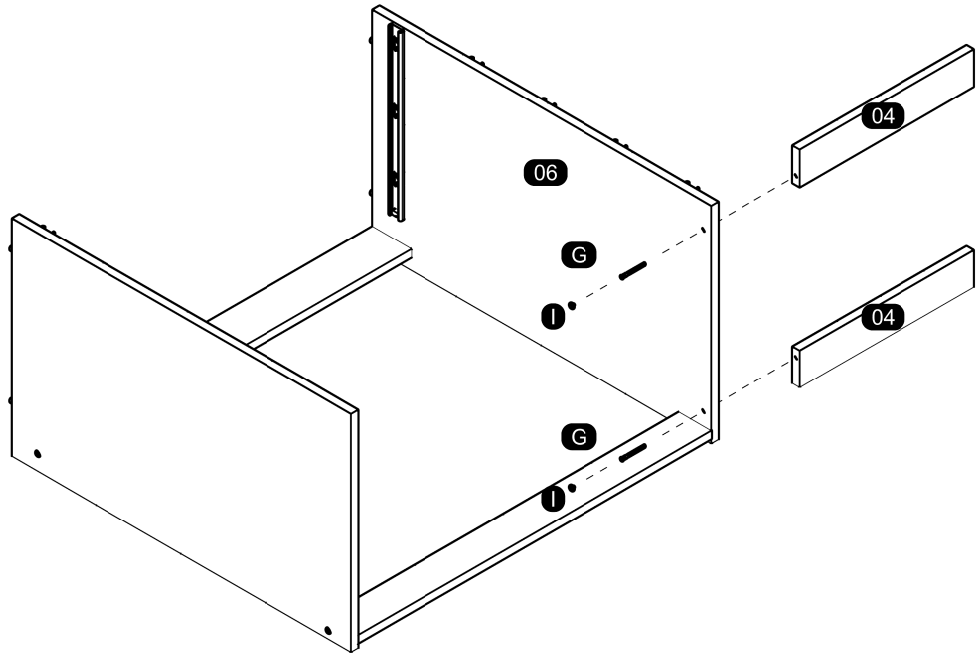

12

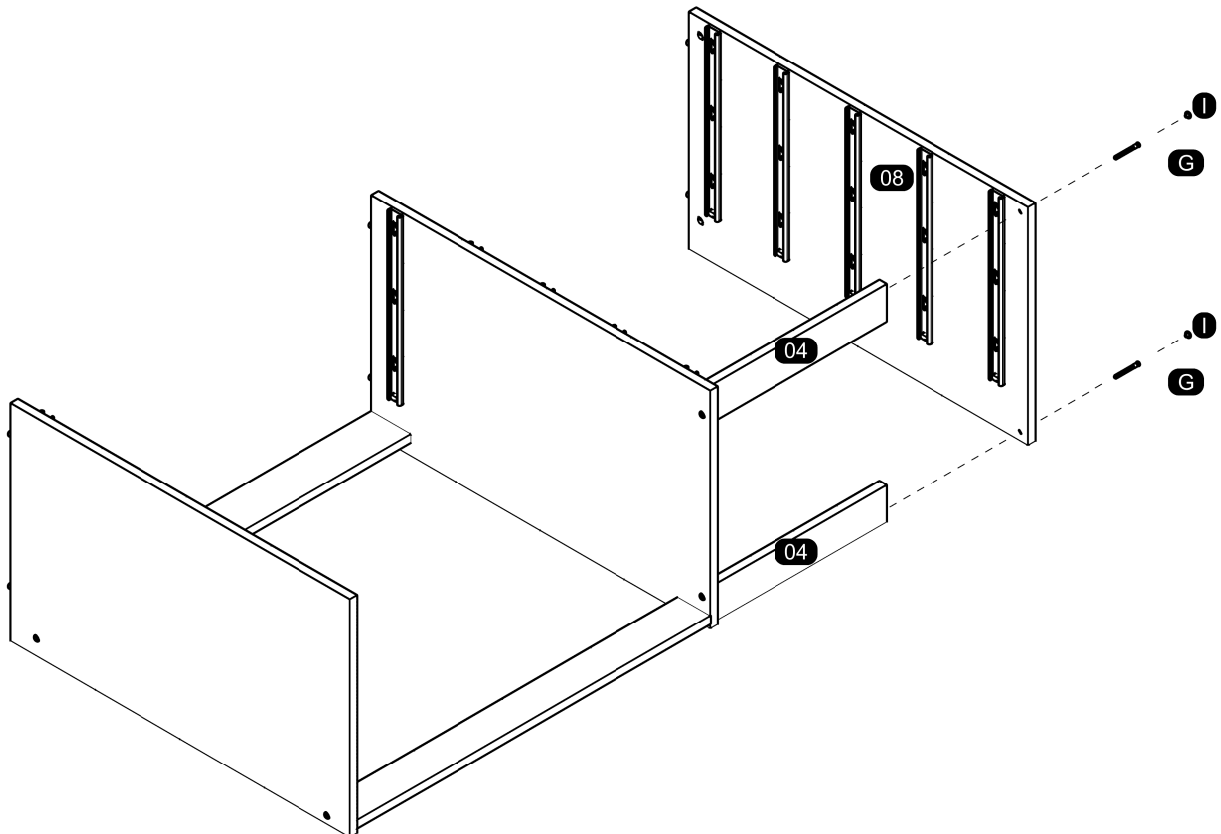

13

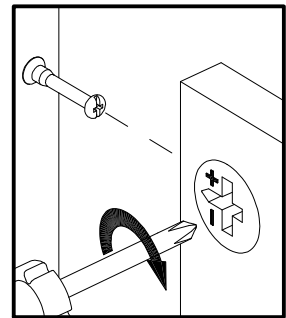
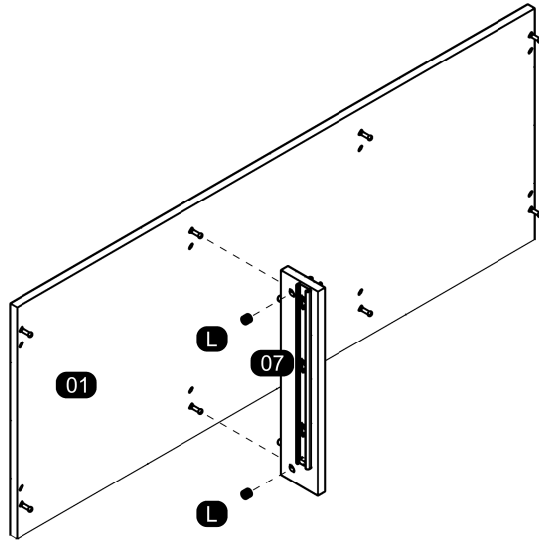

14

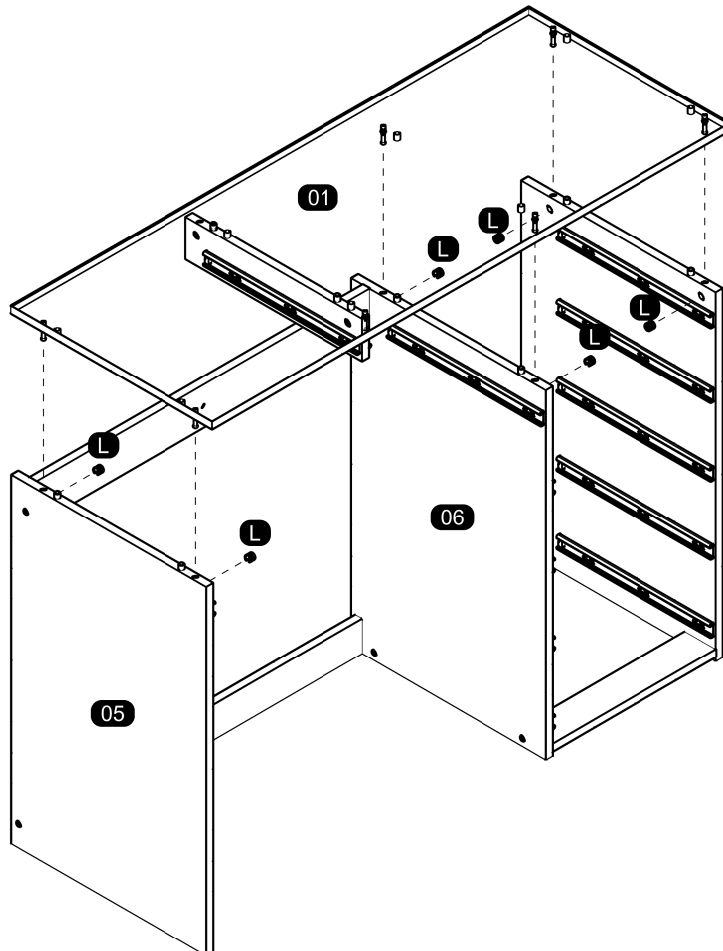

15

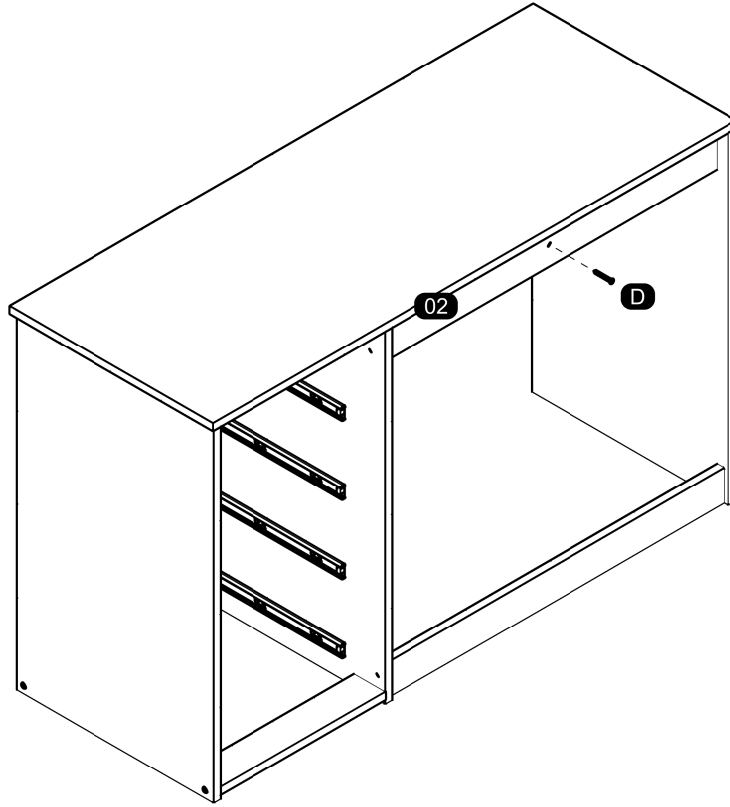

16

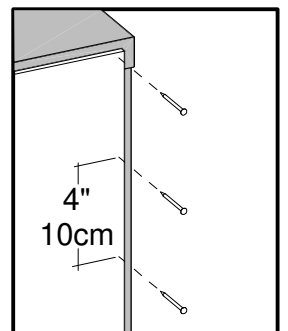
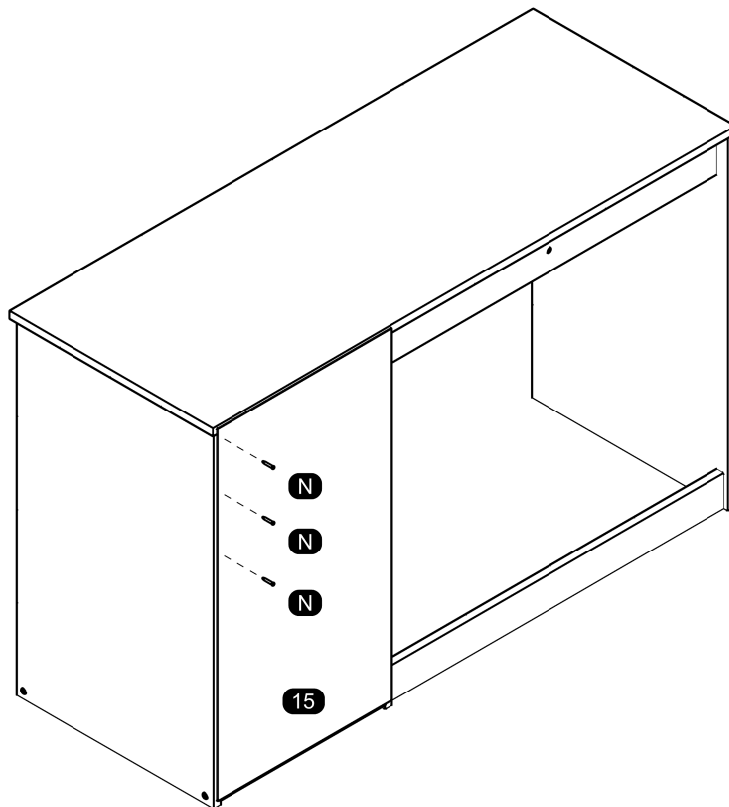

16

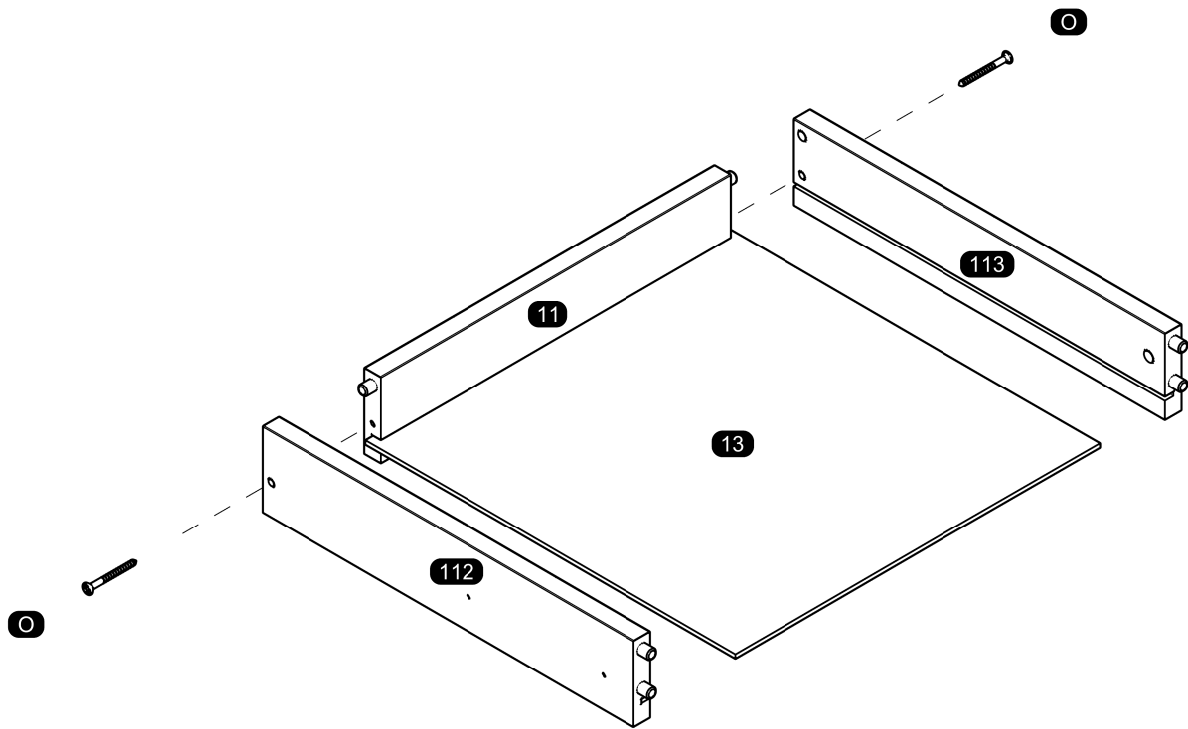

17

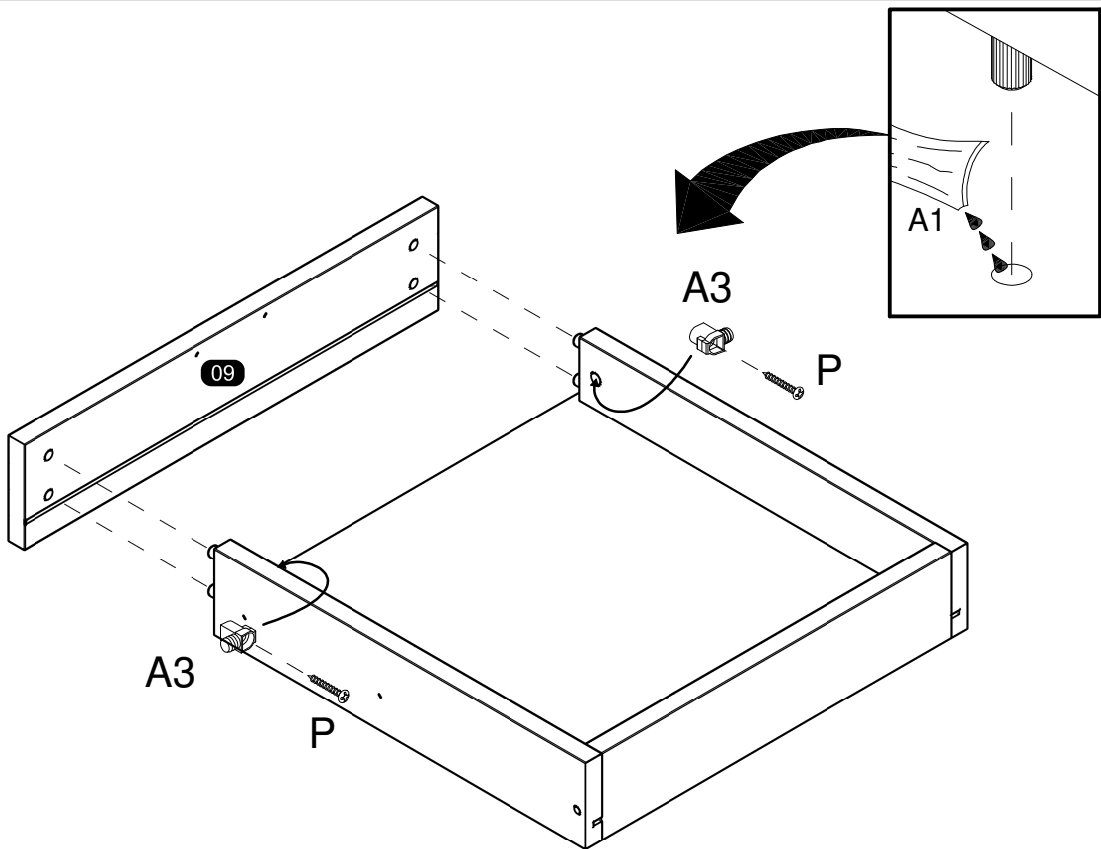

18

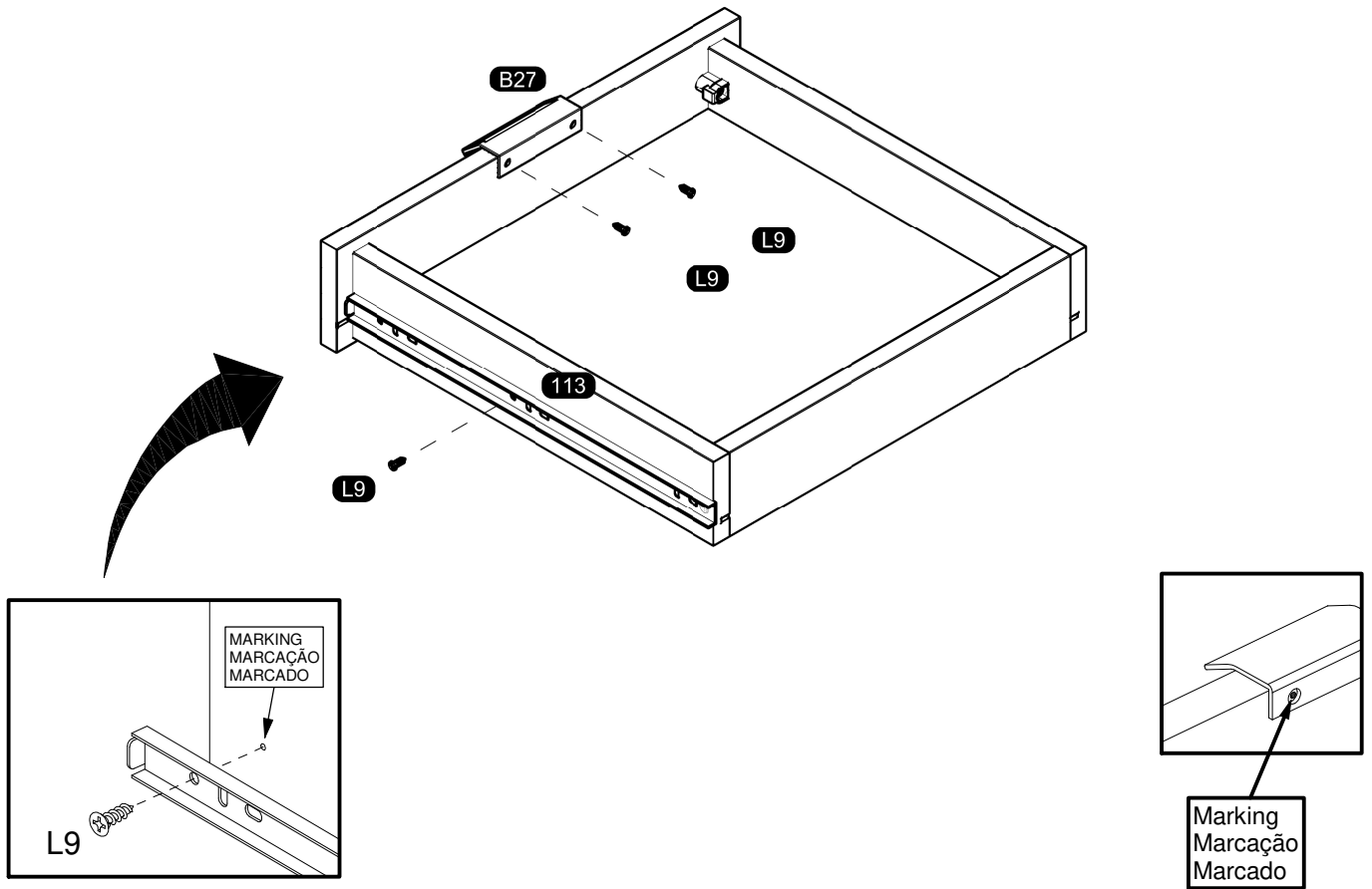

19

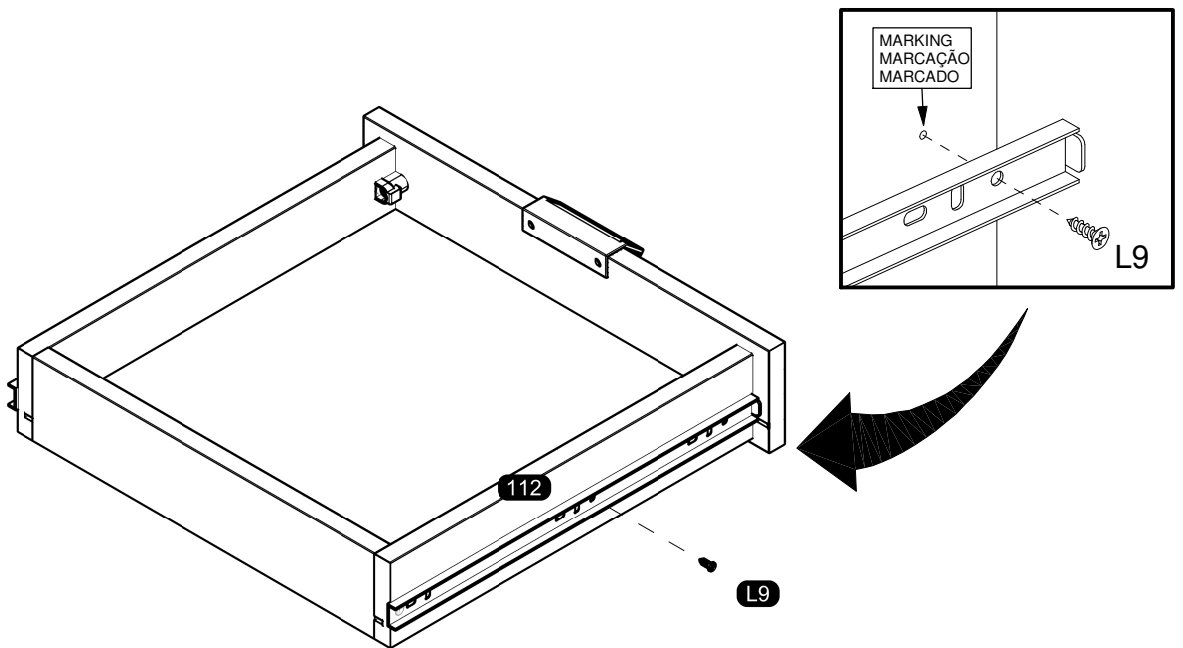

20

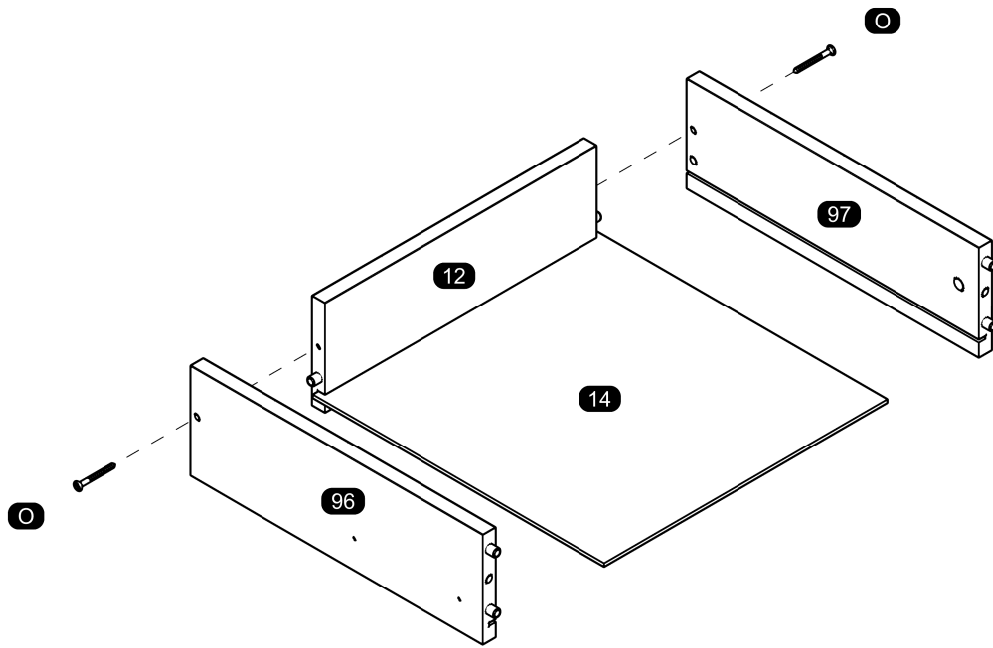

21

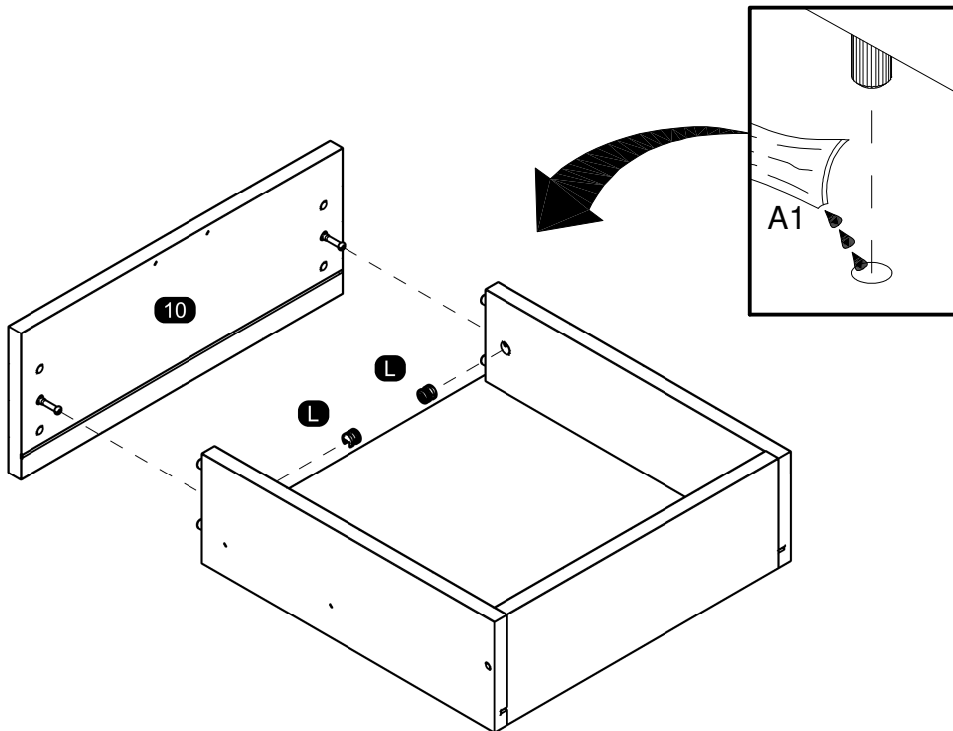

22

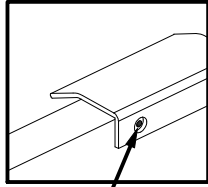

Marking
Marcação
Marcado

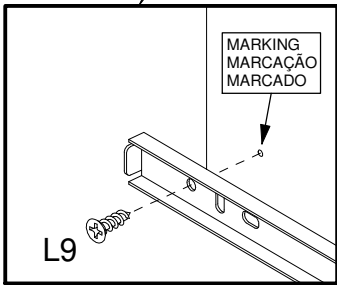
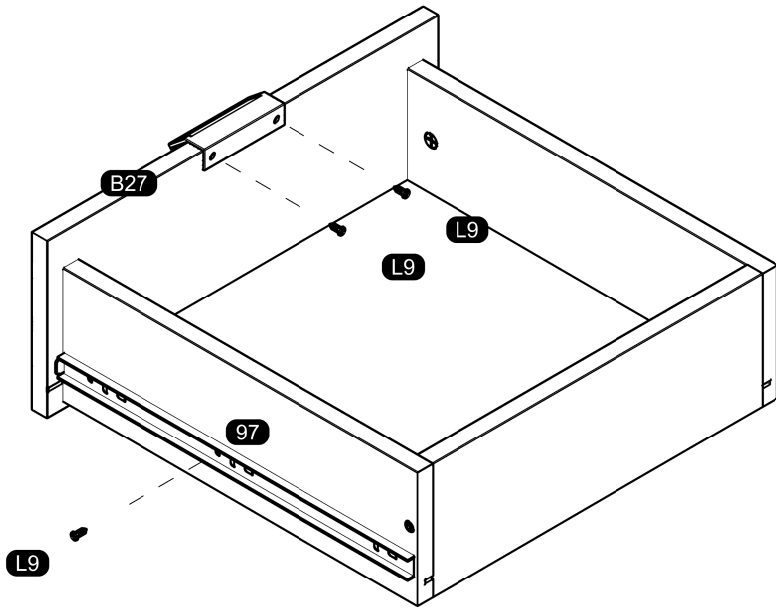

23

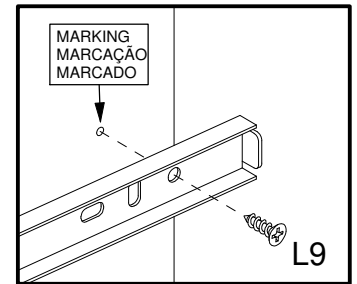
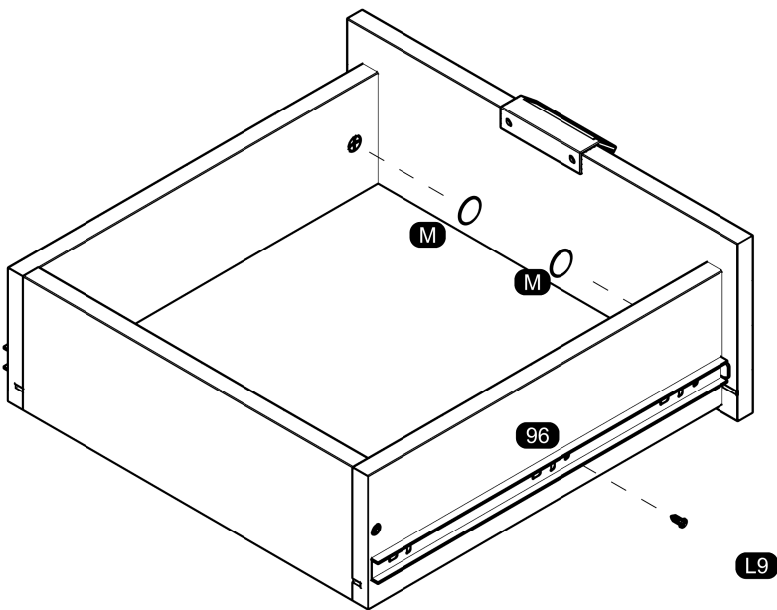

24

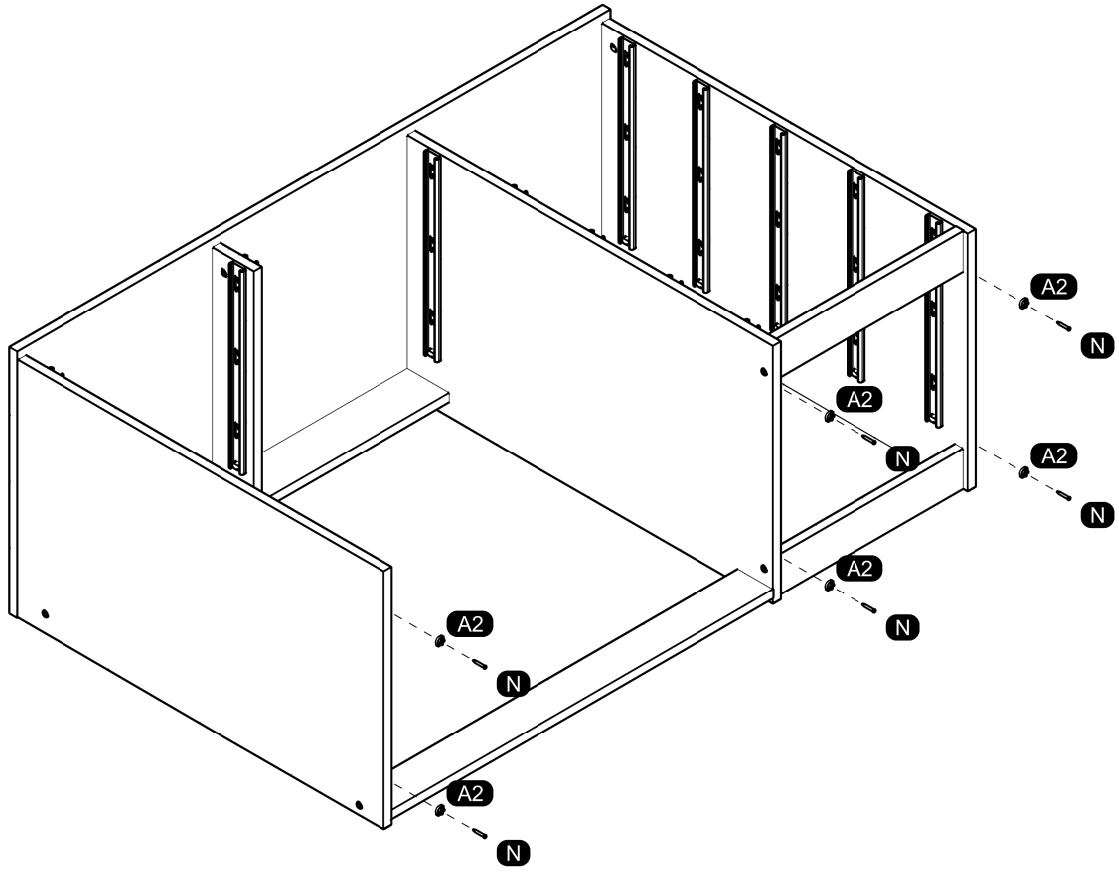

25

