

ASSEMBLY INSTRUCTIONS MANUAL DE MONTAGEM / INSTRUCCIONES DE ARMADO

INFANTO JUVENIL TABLE 1 DOOR
MESA 1 PORTA INFANTO JUVENIL
MESA 1 PUERTA INFANTO JUVENIL

230133
 Reference | Revisão | 00
 Referência | Revisão |
 Referencia | Revisión |
230134
230135

 ENGLISH
PORTUGUÊS
ESPAÑOL

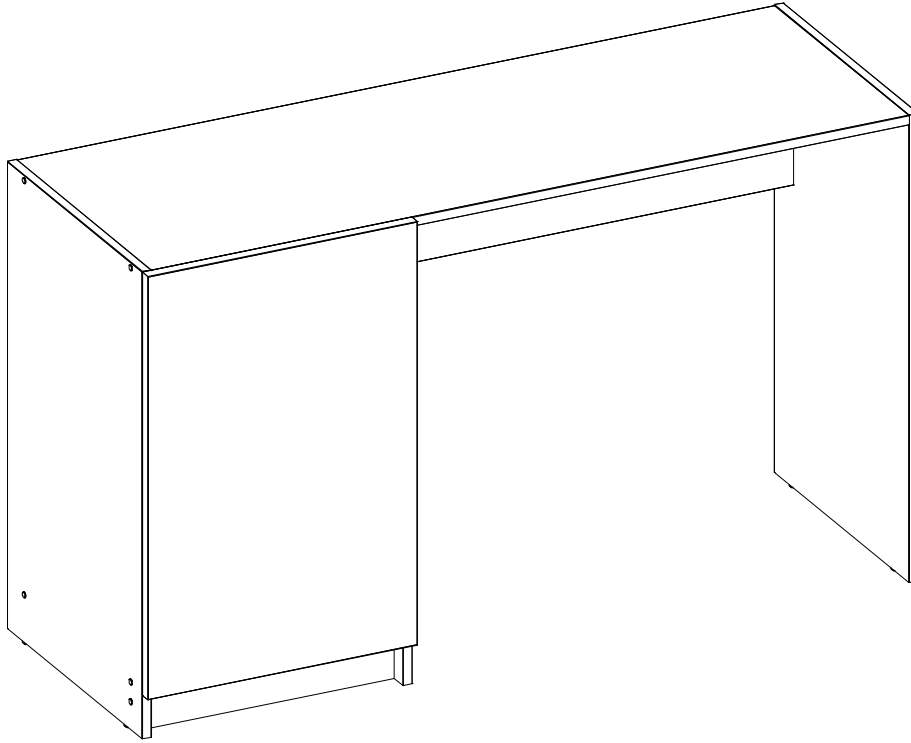

MAXIMUM RECOMMENDED WEIGHT
BEING THIS EVENLY DISTRIBUTED.

PESO MÁXIMO RECOMENDADO SENDO
ESTE DISTRIBUÍDO UNIFORMEMENTE.

PESO MÁXIMO RECOMENDADO SIENDO
ESTE UNIFORMEMENTE DISTRIBUIDO.

	LB	KG
–		
D	11	5
F	22	10
H	44	20

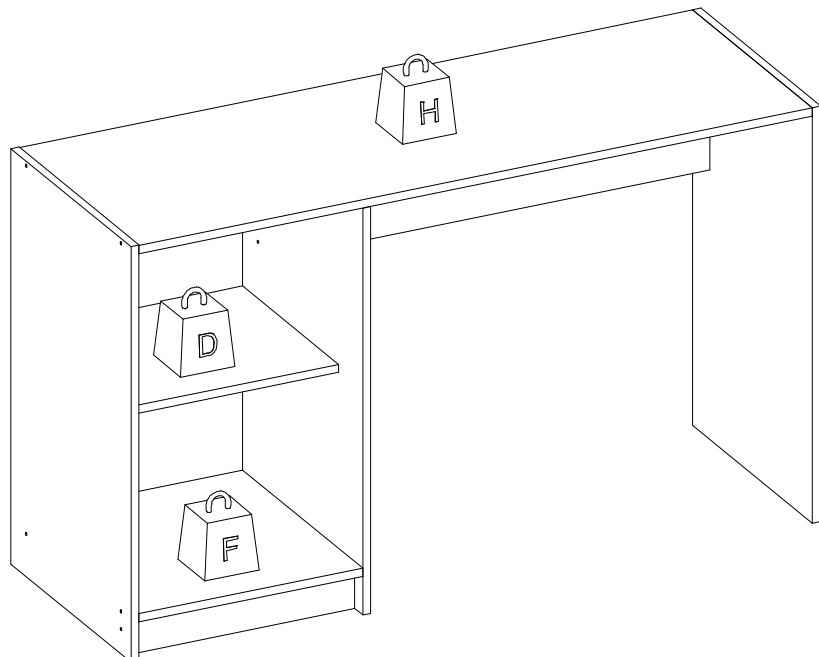

N°	Measures_Inches	Medidas_cm	Qty./Qtd.
01	49 1/4 x 17 1/2 x 5/8	125.0 x 44.5 x 1.5	1
02	16 3/8 x 14 x 5/8	41.5 x 35.5 x 1.5	1
03	16 3/8 x 17 1/2 x 5/8	41.5 x 44.5 x 1.5	1
04	29 3/4 x 17 1/2 x 5/8	75.5 x 44.5 x 1.5	1
05	29 1/8 x 17 1/2 x 5/8	73.9 x 44.5 x 1.5	1
06	29 3/4 x 17 1/2 x 5/8	75.5 x 44.5 x 1.5	1
07	16 3/8 x 2 3/4 x 5/8	41.5 x 7.0 x 1.5	1
08	32 1/4 x 9 7/8 x 5/8	82.0 x 25.0 x 1.5	1
09	26 1/2 x 17 1/8 x 1/8	67.4 x 43.5 x 0.3	1
50	26 7/8 x 17 1/2 x 3/4	68.4 x 44.5 x 1.8	1

PARTS IDENTIFICATION IDENTIFICAÇÃO DAS PEÇAS / IDENTIFICACIÓN DE LAS PIEZAS

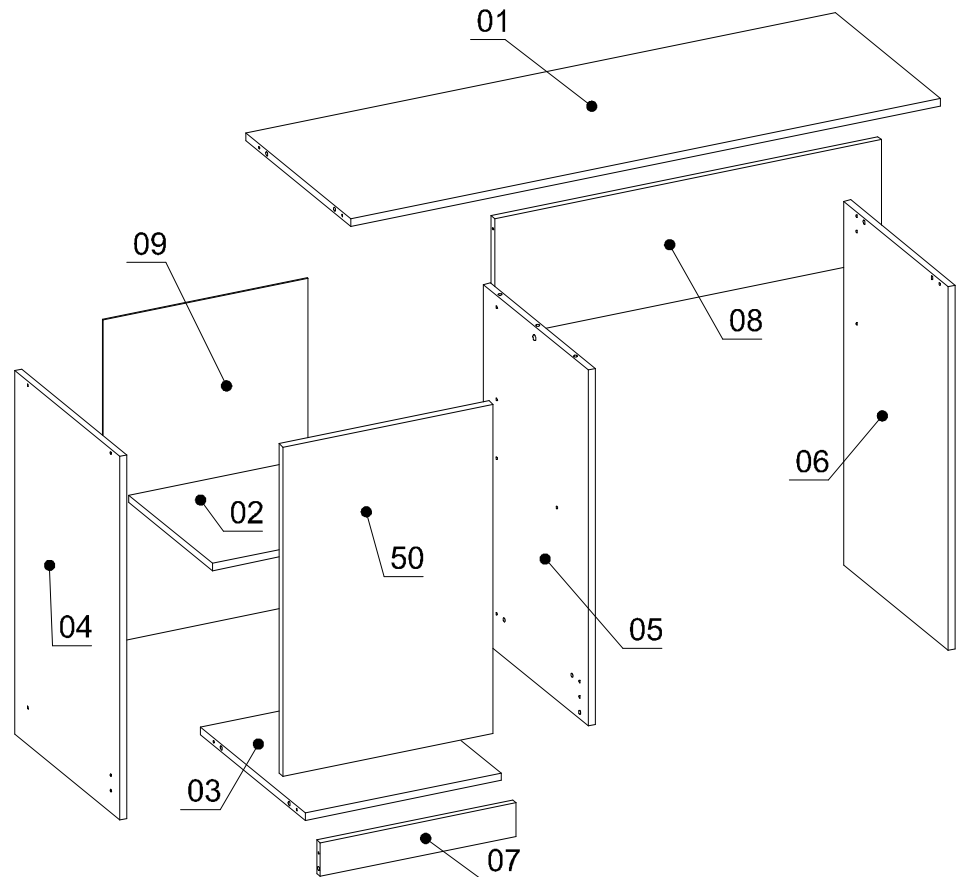

YOU WILL NEED / VOCÊ VAI PRECISAR DE / USTED NECESITARÁ

Tools not supplied / Ferramentas não fornecidas / Herramientas no incluidas

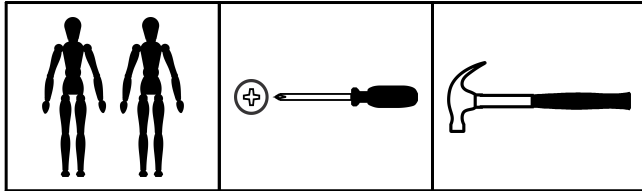

2 People
2 Pessoas
2 Personas

Screwdriver Phillips
Chave Phillips
Destornillador cruz

Hammer
Martelo
Martillo













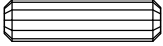

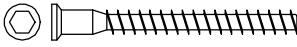
The separation of the accessories before you start the assembly will facilitate the same. In case of doubt on the size of the screws and bolts, use the ruler to bottom of page 3.

A separação dos acessórios antes de iniciar a montagem facilitará a mesma. Em caso de dúvida no tamanho dos parafusos e cavilhas, utilize a régua ao final da página 3.

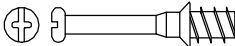
La separación de los accesorios antes de comenzar el armado facilitará el mismo. En caso de duda sobre el tamaño de los tornillos y taquetes, utilice la regla al pie de página 3.

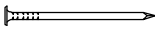
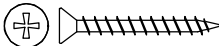
IDENTIFICATION OF ACCESSORIES IDENTIFICAÇÃO DOS ACESSÓRIOS/ IDENTIFICACIÓN DE ACCESORIOS

A2		Small plastic foot / Sapata redonda / Pie plástico	14 mm	6
D5		Hinge shim / Calço dobradiça / Bisagra de calce	-	2
E		Wooden dowel / Cavilha / Taquete	8x30 mm	12
F9		Metal hinge straight / Dobradiça reta / Bisagra recta	26 mm	2
G		Structural screw / Parafuso estrutural / Tornillo estructural	5,0x50 mm	14
H		Allen key / Chave allen / Liave allen	3 mm	1
H8		Shelf bracket / Suporte de prateleira / Suporte de repisa	6x8 mm	4
I		Structural screw cover/Tampa parafuso estrutural/Tapa tornillo estructural	-	14
J		Simple minifix screw / Haste minifix simples / Tornillo minifix simple	-	1
L		Drum lock / Tambor minifix / Tambor minifix	12 mm	1
M		Bore patch adhesive / Tapa furo adesivo / Tapones adhesivo	-	1
N		Nail / Pregos / Clavo	10x10	28
R3		Flat head screw / Parafuso chato / Tornillo de cabeza plana	3,5x30 mm	2
S		Pan head screw / Parafuso panela / Tornillo de pan	3,5x14 mm	8

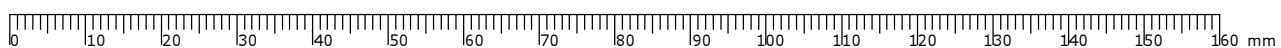

PRE-ASSEMBLE
PRÉ-MONTAGE / PRE ARMADO

01

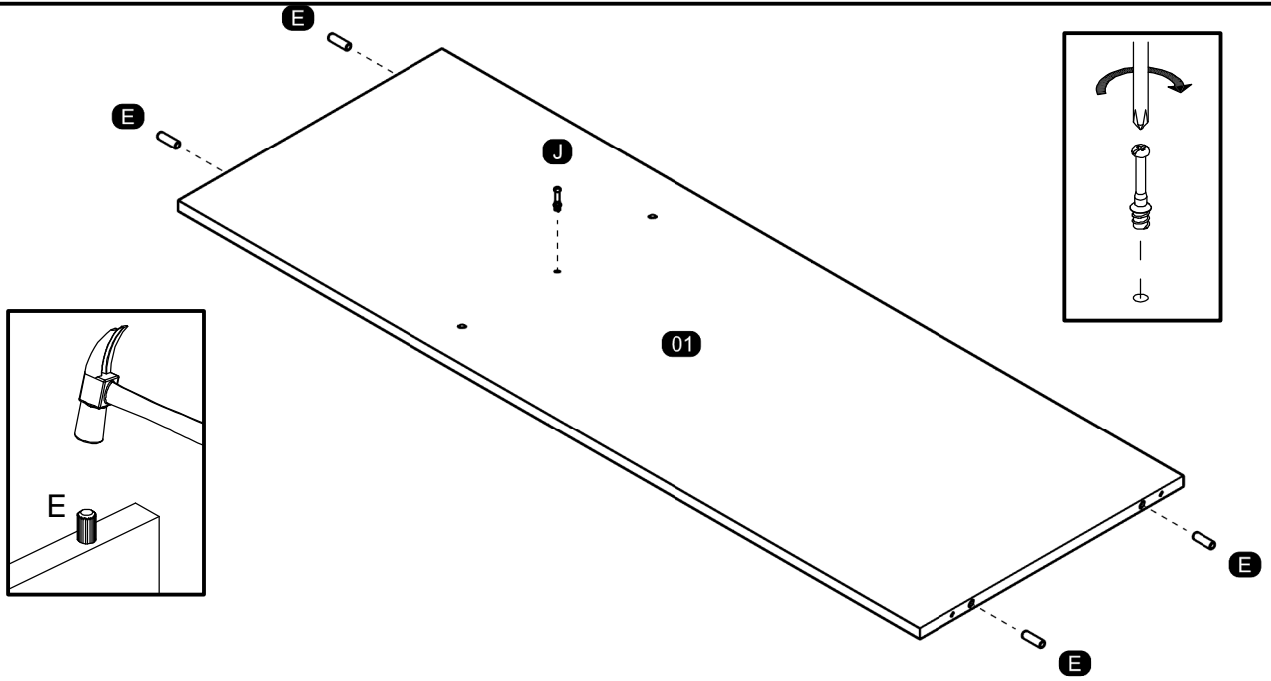

02

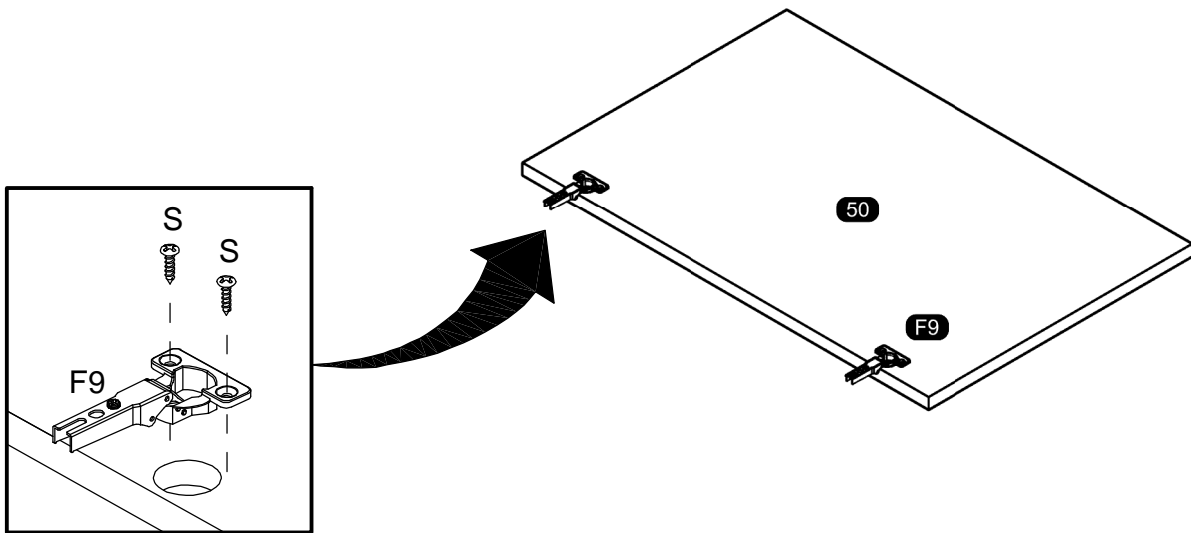

03

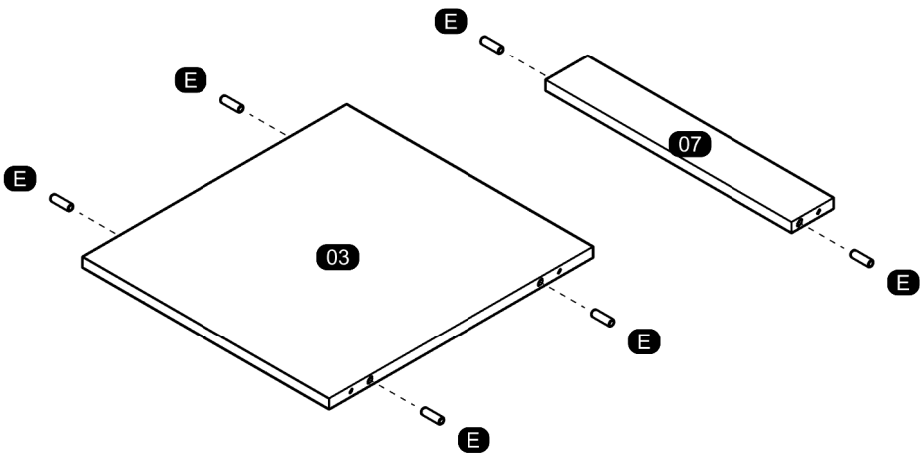

04

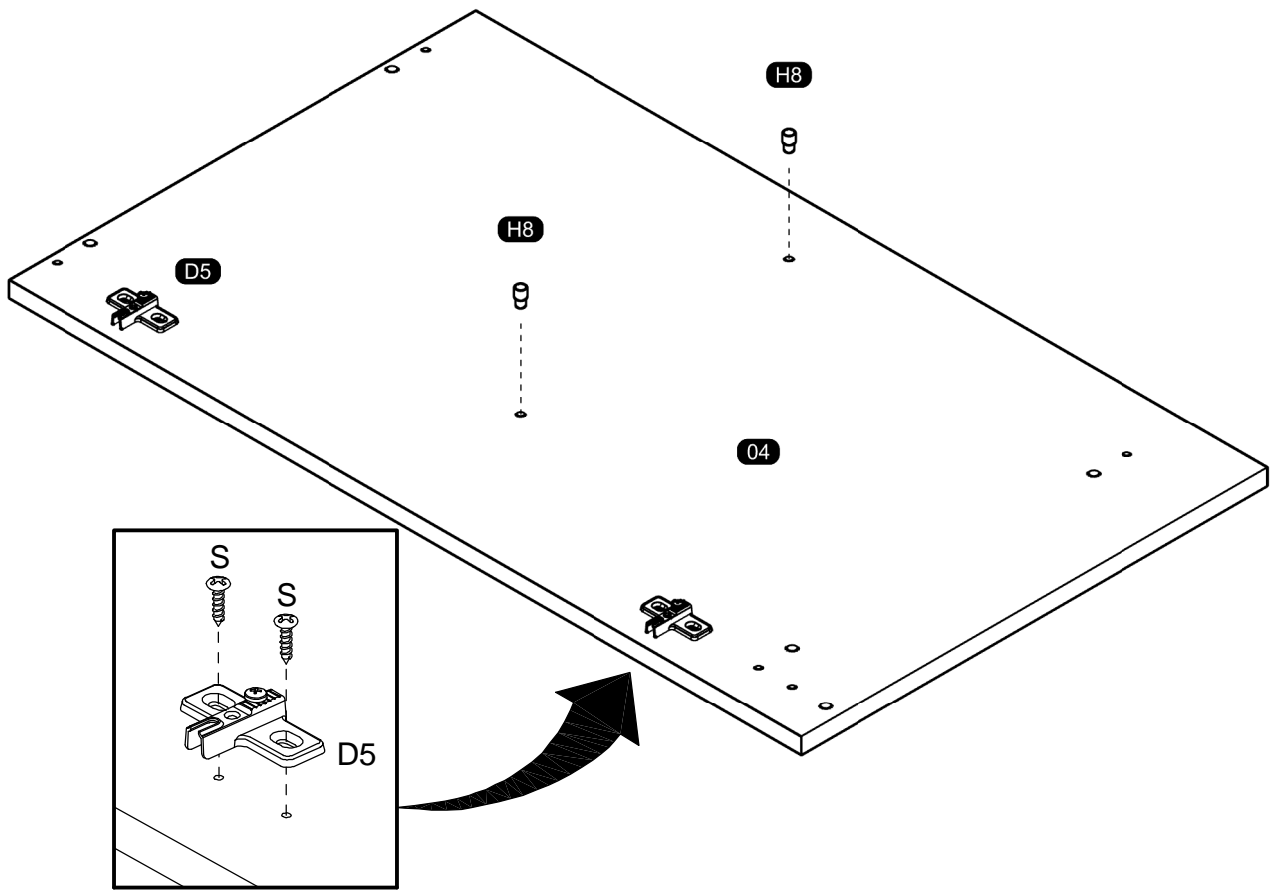

05

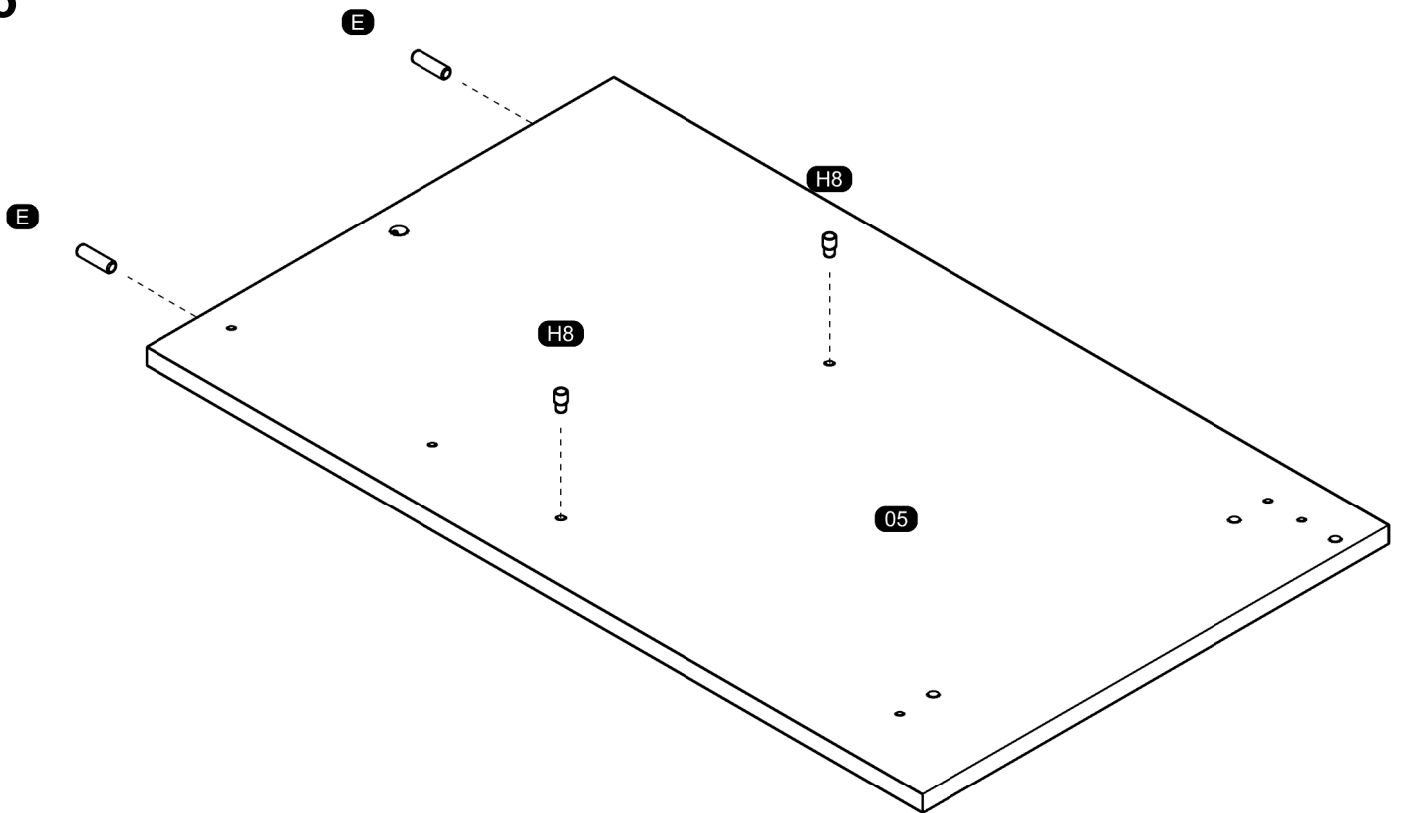

ASSEMBLY
MONTAGEM / ARMADO

06

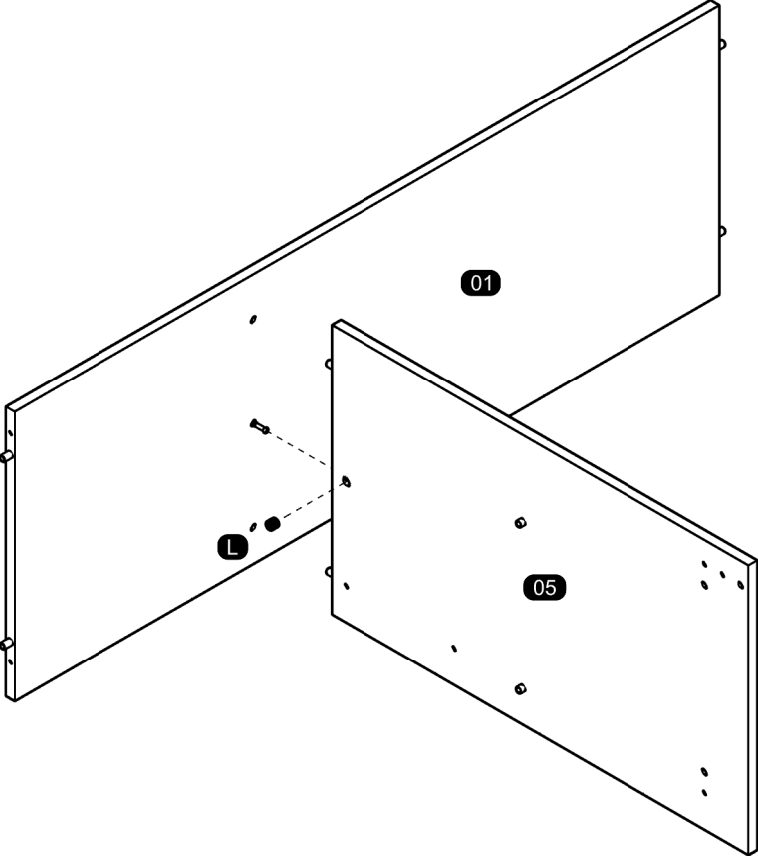

07

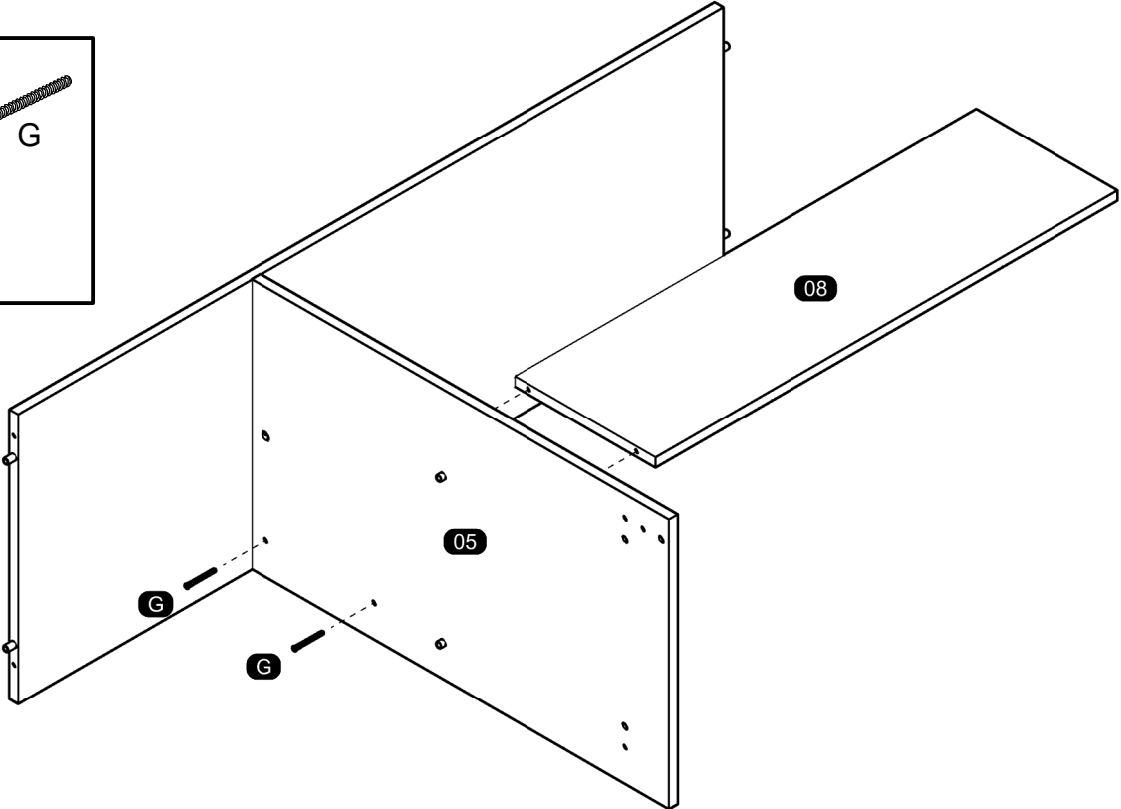
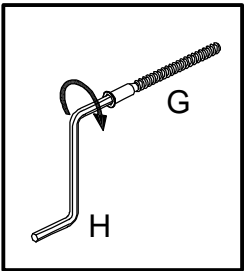

08

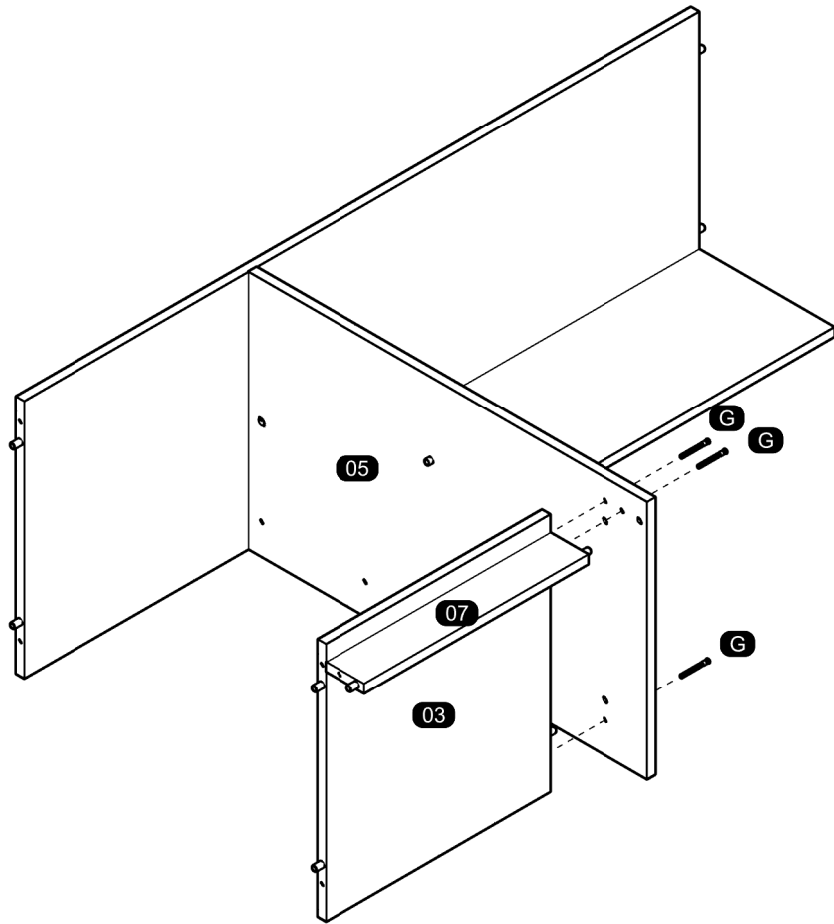

09

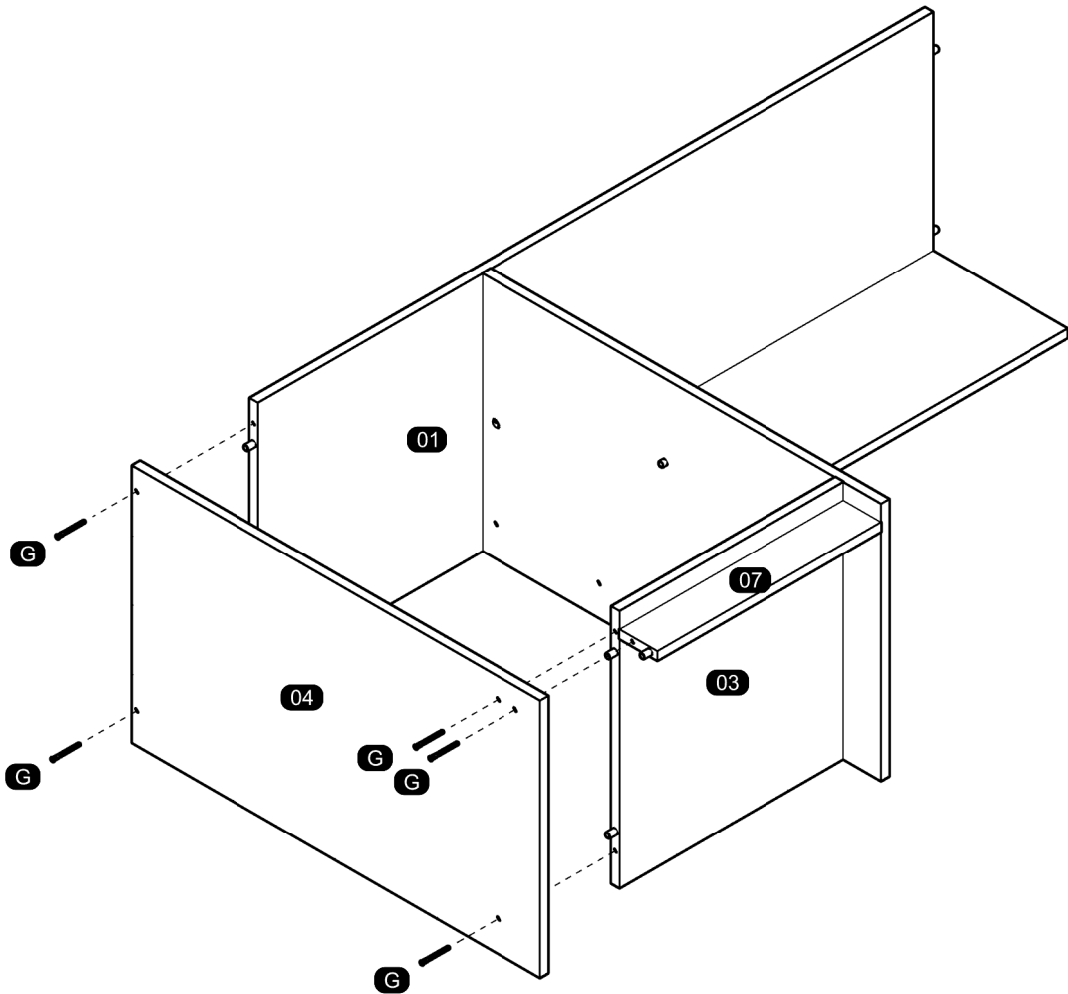

10

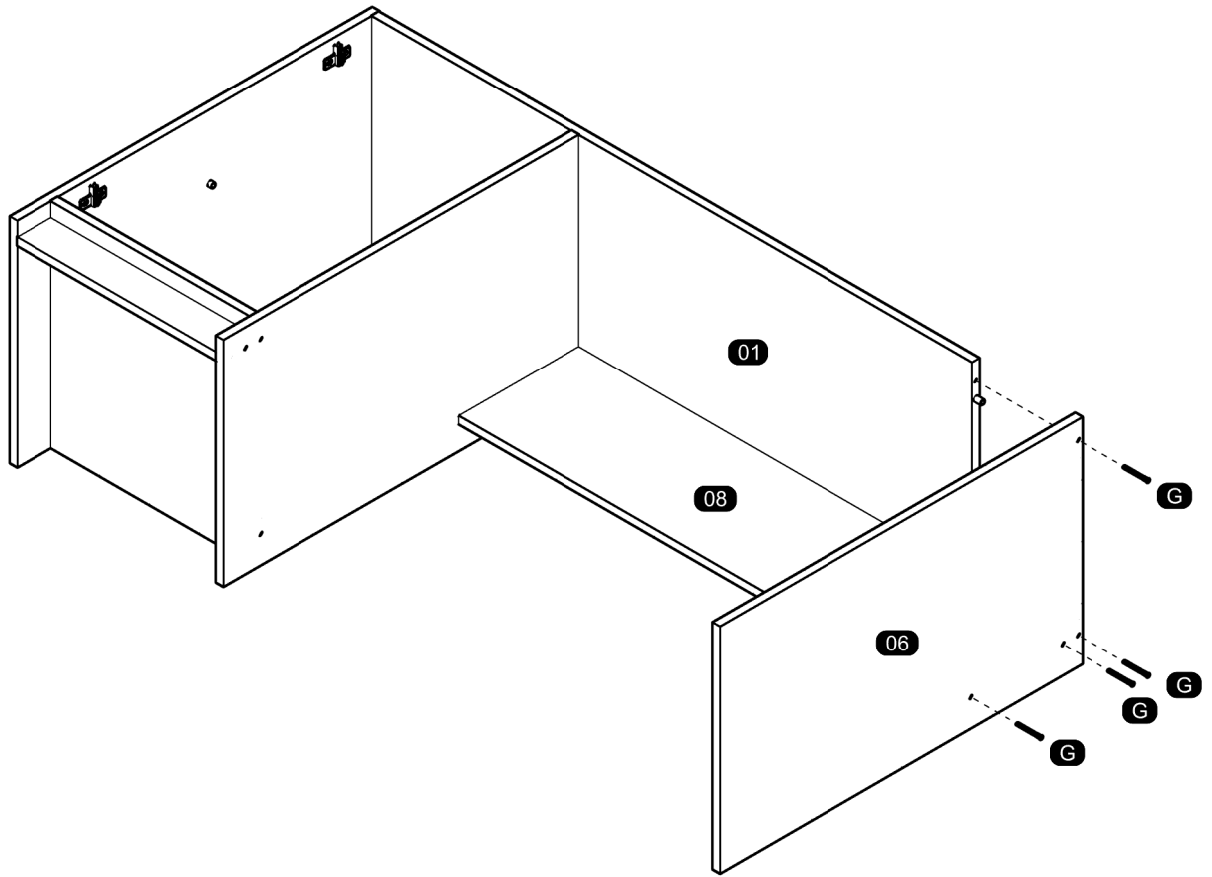

11

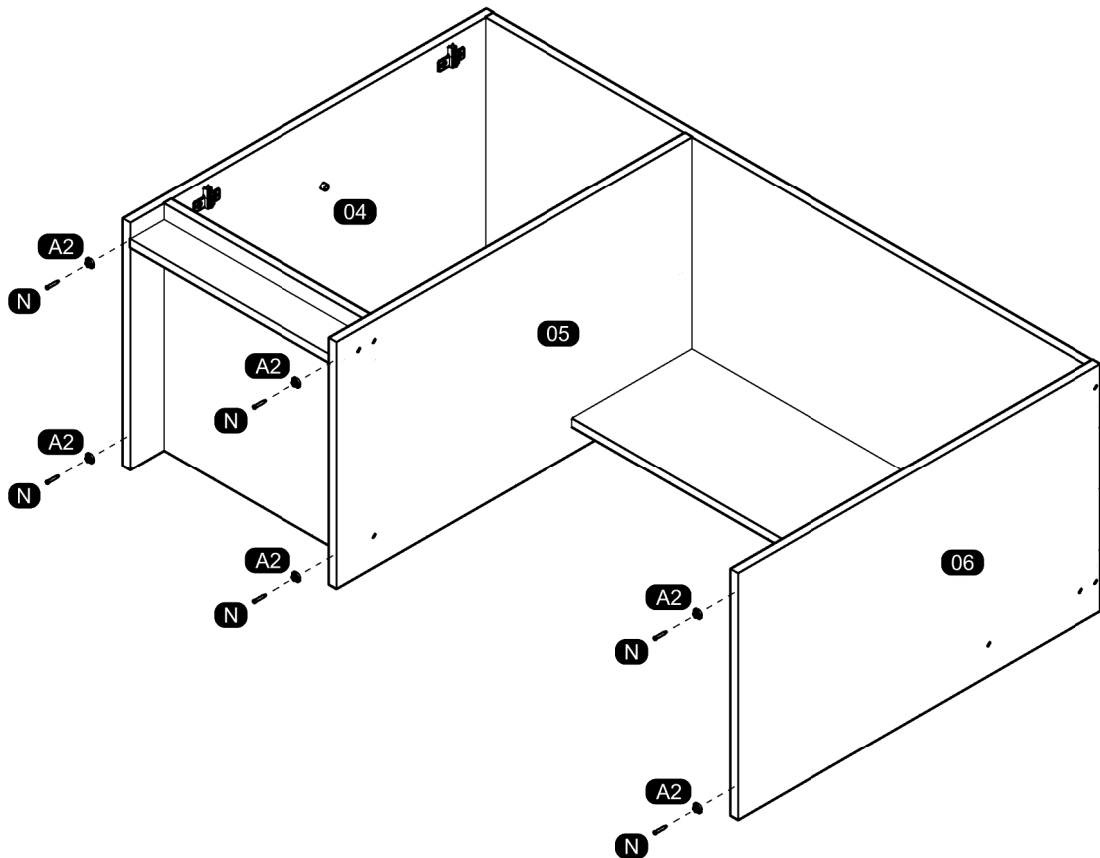

12

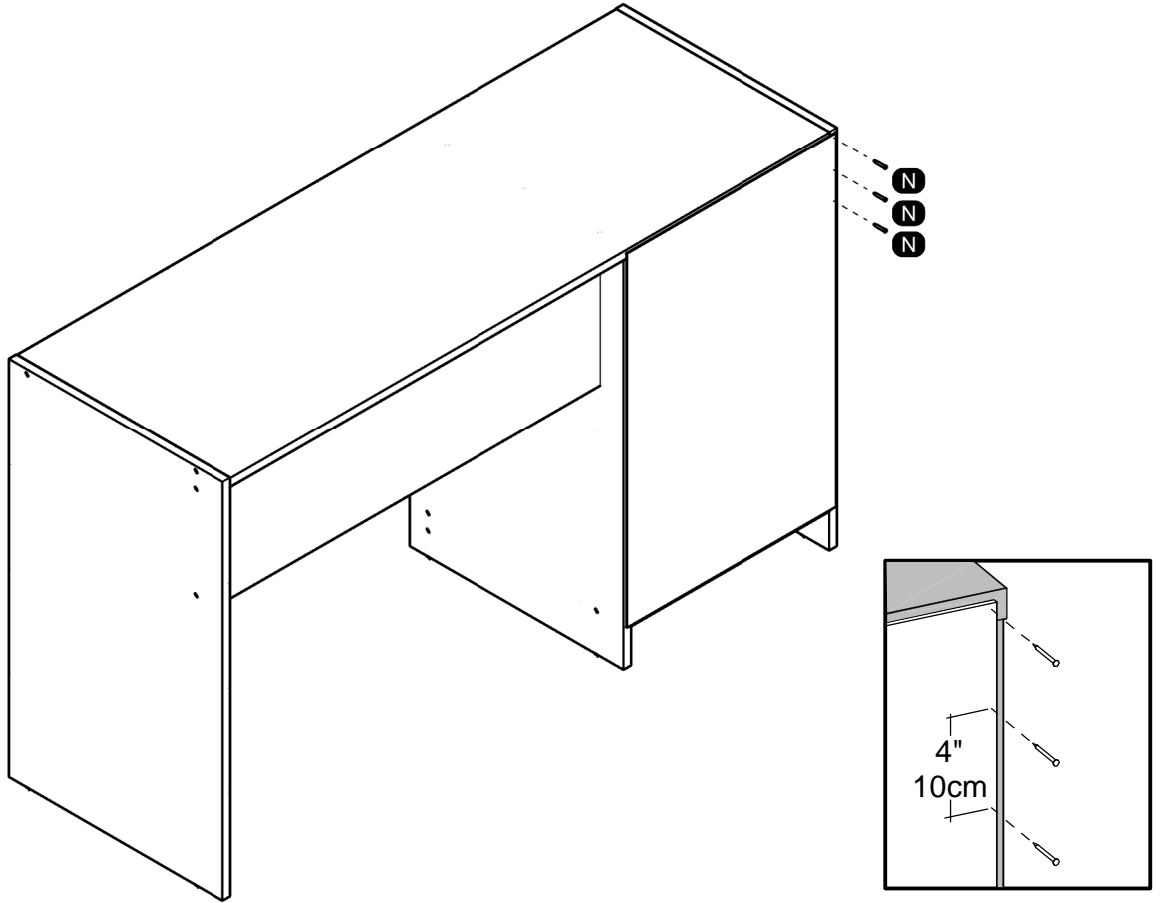

13

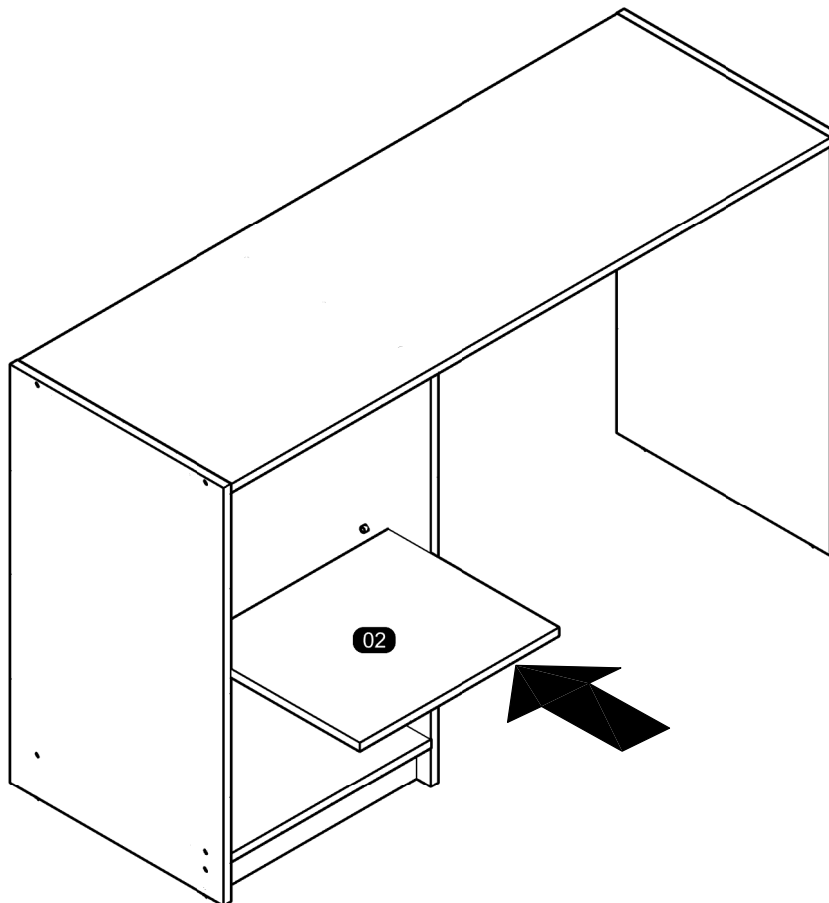

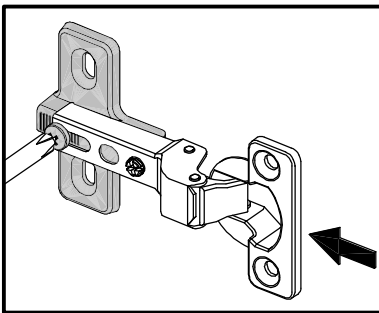
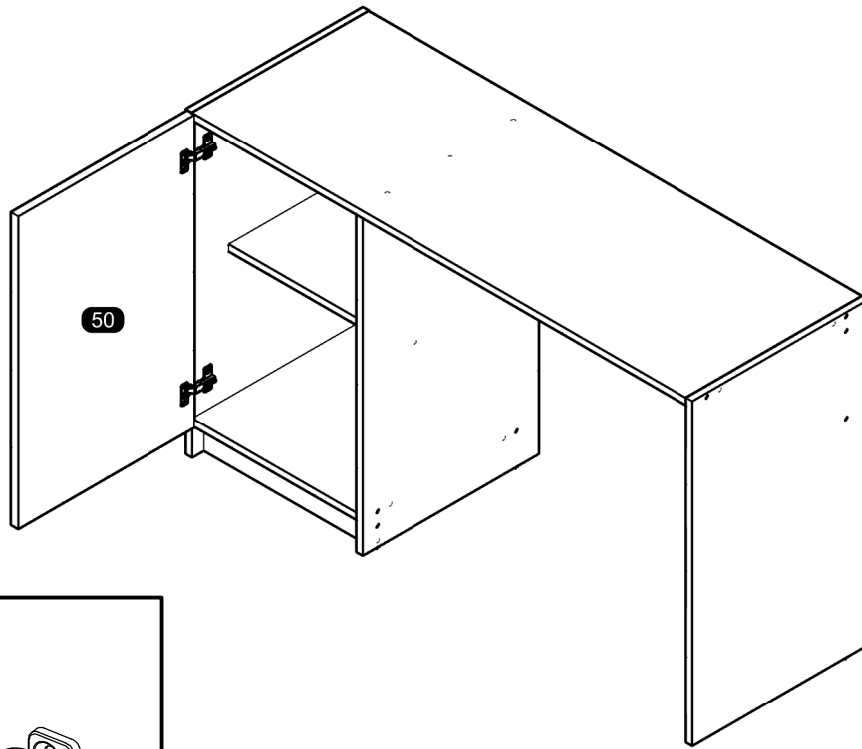

15

At the end of the assembly, insert the screw cover / hole plugs in the apparent holes.
 Ao final da montagem, insira a(s) tampa(s) de parafuso / tapa furos nos furos que ficarem aparentes.
 Al final del conjunto, coloque la tapa tornillo / tapón plástico en los agujeros que se hagan evidentes.

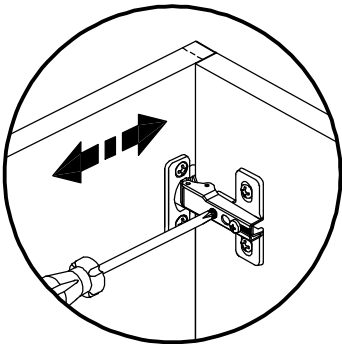

Horizontal Adjustment
 Regulagem Horizontal
 Ajuste Horizontal

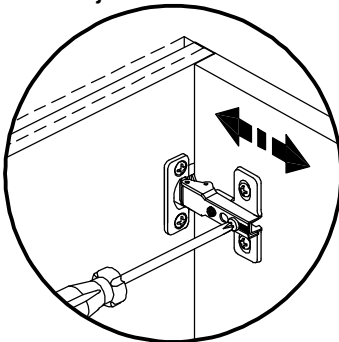

Depth Adjustment
 Regulagem Profundidade
 Ajuste Profundidad

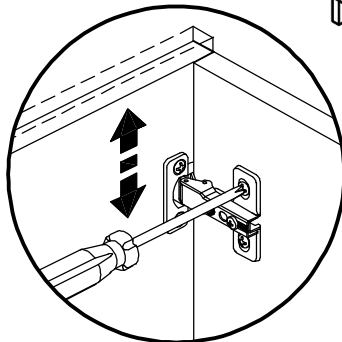

Vertical Adjustment
 Regulagem Vertical
 Ajuste Vertical

