

ASSEMBLY INSTRUCTIONS MANUAL DE MONTAGEM / INSTRUCCIONES DE ARMADO

MAX AIR TV STAND GAMER AND OFFICE 36 5/8

RACK GAMER E ESCRITÓRIO MAX AIR 93 CM

RACK GAMER Y OFICINA MAX AIR 93 CM

Reference
Referência
Referencia

220427

Revisé
Revisão
Revisión

00



ENGLISH
PORTUGUÊS
ESPAÑOL

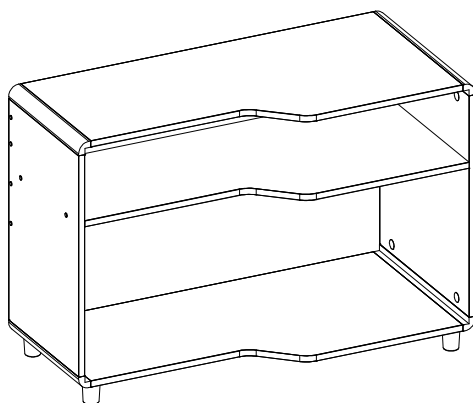

MAXIMUM RECOMMENDED WEIGHT
BEING THIS EVENLY DISTRIBUTED.

PESO MÁXIMO RECOMENDADO SENDO
ESTE DISTRIBUÍDO UNIFORMEMENTE.

PESO MÁXIMO RECOMENDADO SIENDO
ESTE UNIFORMEMENTE DISTRIBUIDO.

	LB	KG
–		
F	22	10
G	33	15

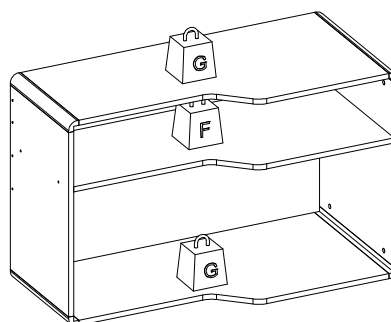

Nº	Measures_Inches	Medidas_cm	Qty./Qtd.
01	34 1/4 x 17 3/8 x 5/8	87.0 x 44.2 x 1.5	2
02	35 3/8 x 17 3/8 x 5/8	90.0 x 44.2 x 1.5	1
03	21 1/8 x 13 5/8 x 5/8	53.5 x 34.6 x 1.5	1
04	21 1/8 x 17 3/8 x 5/8	53.5 x 44.2 x 1.5	1
05	35 3/8 x 6 7/8 x 5/8	90.0 x 17.5 x 1.5	1
06	35 3/8 x 6 1/8 x 5/8	90.0 x 15.5 x 1.5	1
59	13 5/8 x 1 1/8 x 1 1/8	34.6 x 3.0 x 3.0	2
64	17 3/8 x 1 1/8 x 1 1/8	44.2 x 3.0 x 3.0	2

PARTS IDENTIFICATION IDENTIFICAÇÃO DAS PEÇAS / IDENTIFICACIÓN DE LAS PIEZAS

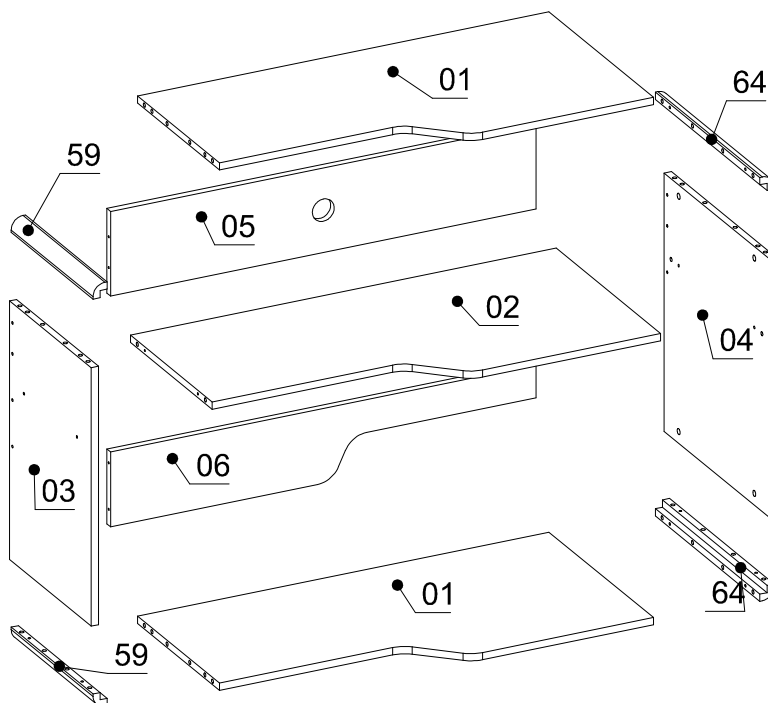

YOU WILL NEED / VOCÊ VAI PRECISAR DE / USTED NECESITARÁ

Tools not supplied / Ferramentas não fornecidas / Herramientas no incluidas

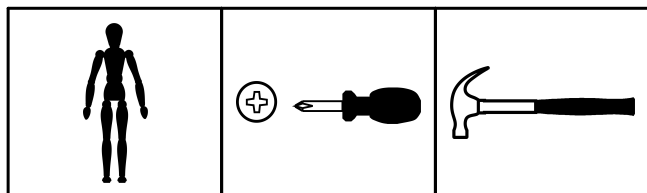

1 Person	Small screwdriver Phillips	Hammer
1 Pessoa	Chave Phillips Menor	Martelo
1 Persona	Destornillador cruz menor	Martillo











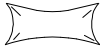

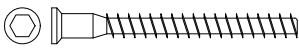
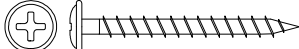
The separation of the accessories before you start the assembly will facilitate the same. In case of doubt on the size of the screws and bolts, use the ruler to bottom of page 3.

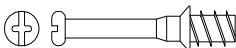
A separação dos acessórios antes de iniciar a montagem facilitará a mesma. Em caso de dúvida no tamanho dos parafusos e cavilhas, utilize a régua ao final da página 3.

La separación de los accesorios antes de comenzar el armado facilitará el mismo. En caso de duda sobre el tamaño de los tornillos y taquetes, utilice la regla al pie de página 3.

IDENTIFICATION OF ACCESSORIES IDENTIFICAÇÃO DOS ACESSÓRIOS/ IDENTIFICACIÓN DE ACCESORIOS

A1		Glue / Cola / Pegamento	13 g	1
E		Wooden dowel / Cavilha / Taquete	8x30 mm	36
E8		Plastic foot / Pé de rack / Pie plástico	50 mm	5
G		Structural screw / Parafuso estrutural / Tornillo estructural	5,0x50 mm	11
G3		Flanged head screw / Parafuso flangeado / Tornillo de cabeza flangeada	5,0x40 mm	5
H		Allen key / Chave allen / Liave allen	3 mm	1
I		Structural screw cover/Tampa parafuso estrutural/Tapa tornillo estructural	-	11
J		Simple minifix screw / Haste minifix simples / Tornillo minifix simple	-	16
L		Drum lock / Tambor minifix / Tambor minifix	12 mm	16
M		Bore patch adhesive / Tapa furo adesivo / Tapones adhesivo	-	12
P6		Pass wires / Passa fios / Pasar cables	46 mm	1
S		Pan head screw / Parafuso panela / Tornillo de pan	3,5x14 mm	12
Y18		Zamac bracket / Cantoneira zamac / Suporte de zamac	13x13 mm	6



PRE-ASSEMBLE
PRÉ-MONTAGEM / PRE ARMADO

01

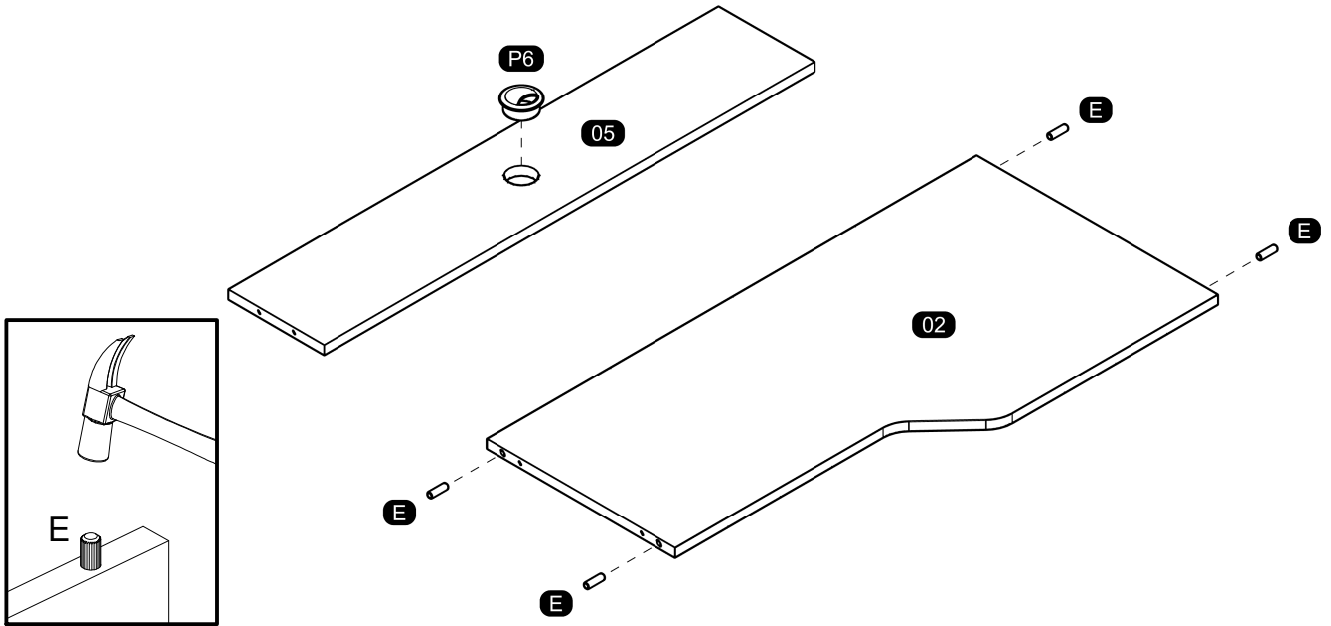

02

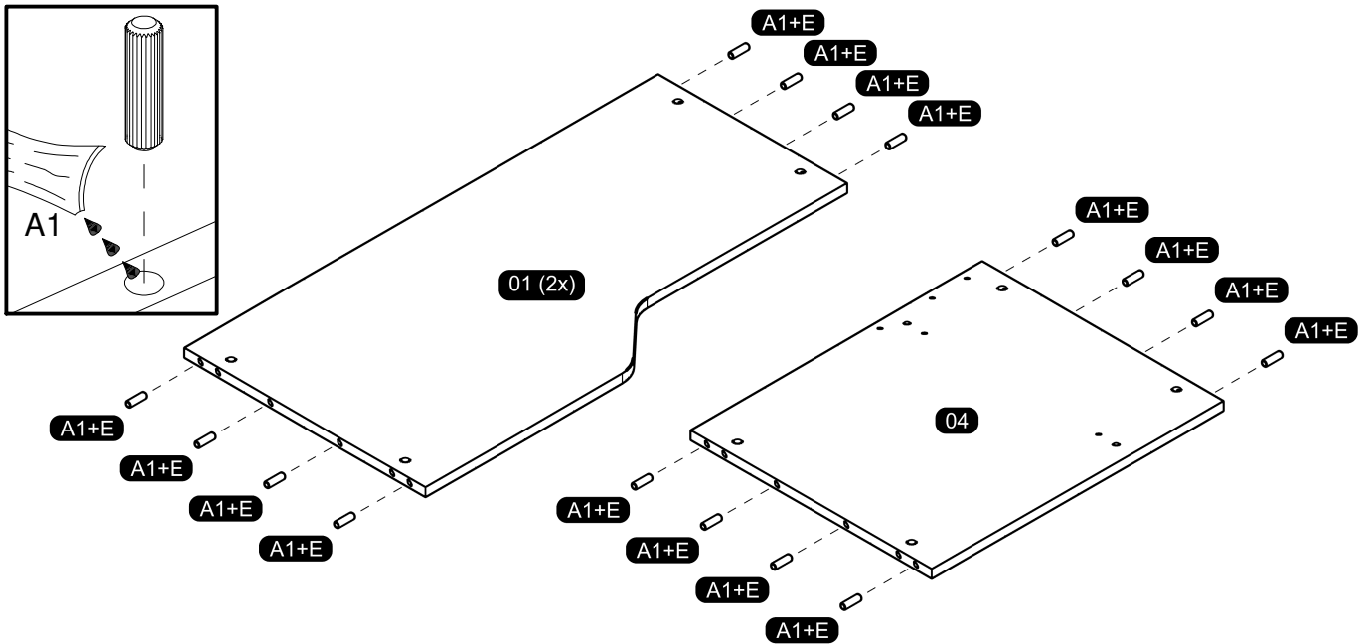

03

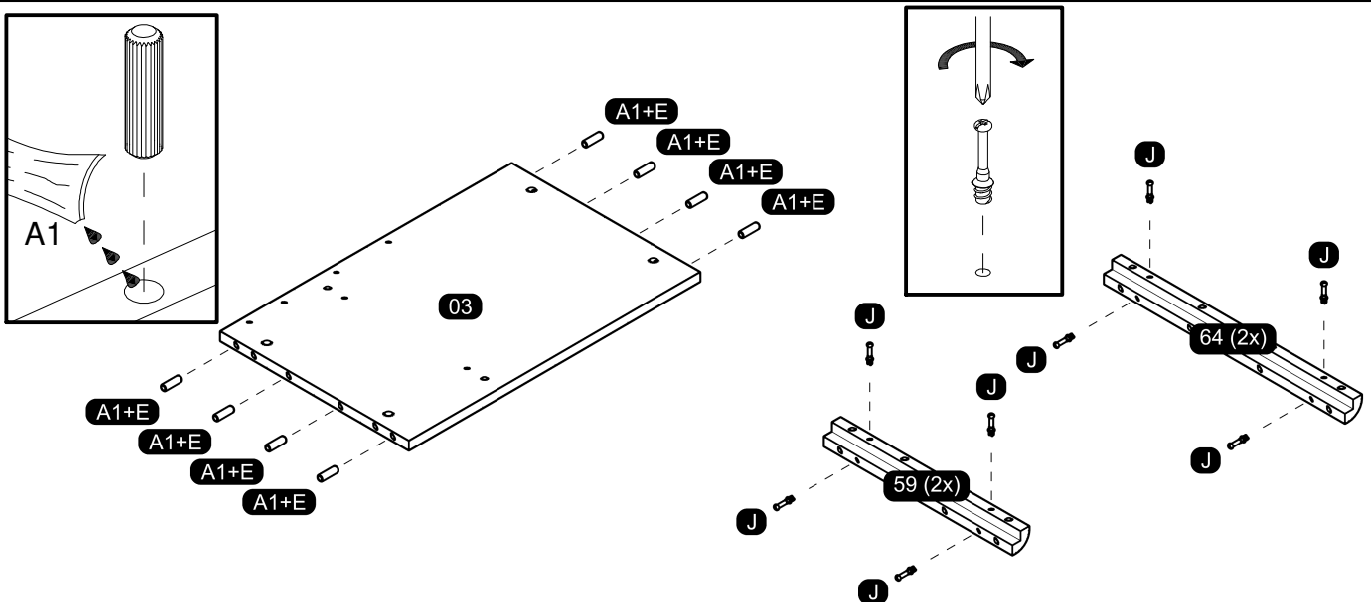

ASSEMBLY
MONTAGEM / ARMADO

04

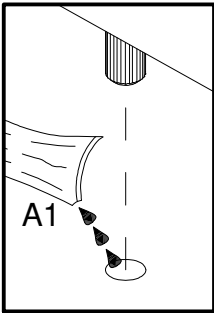
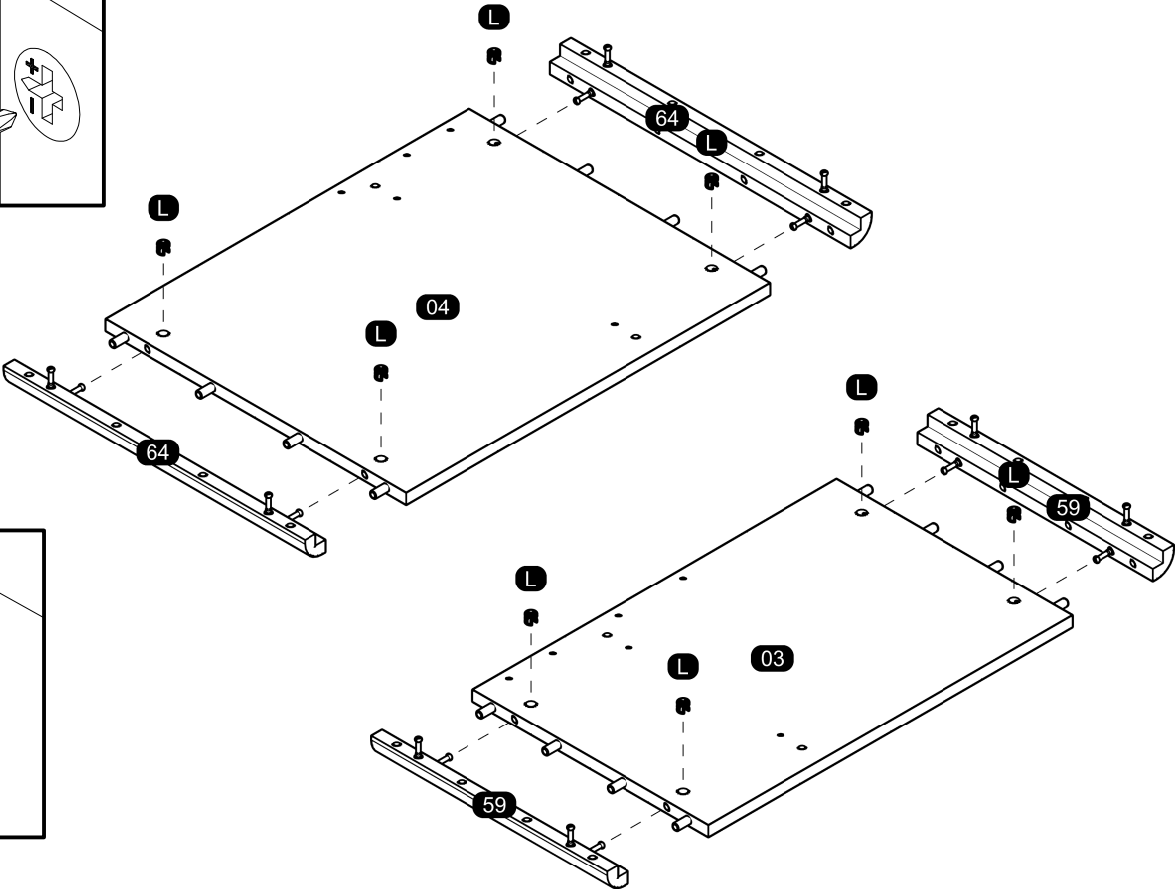
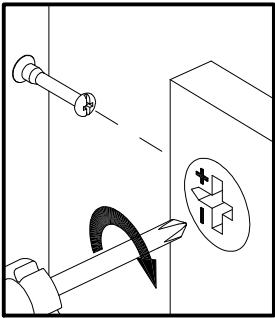

05

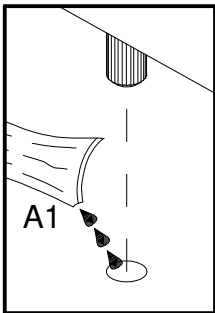
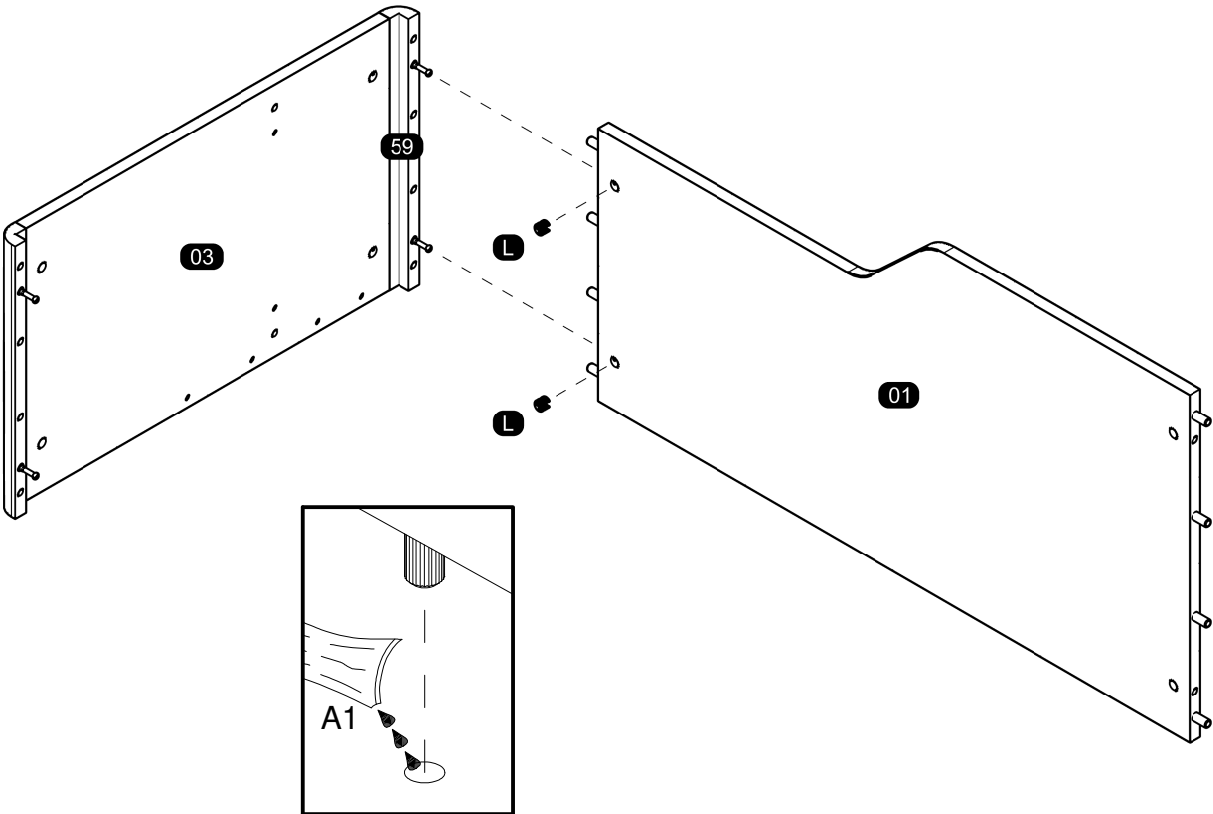

06

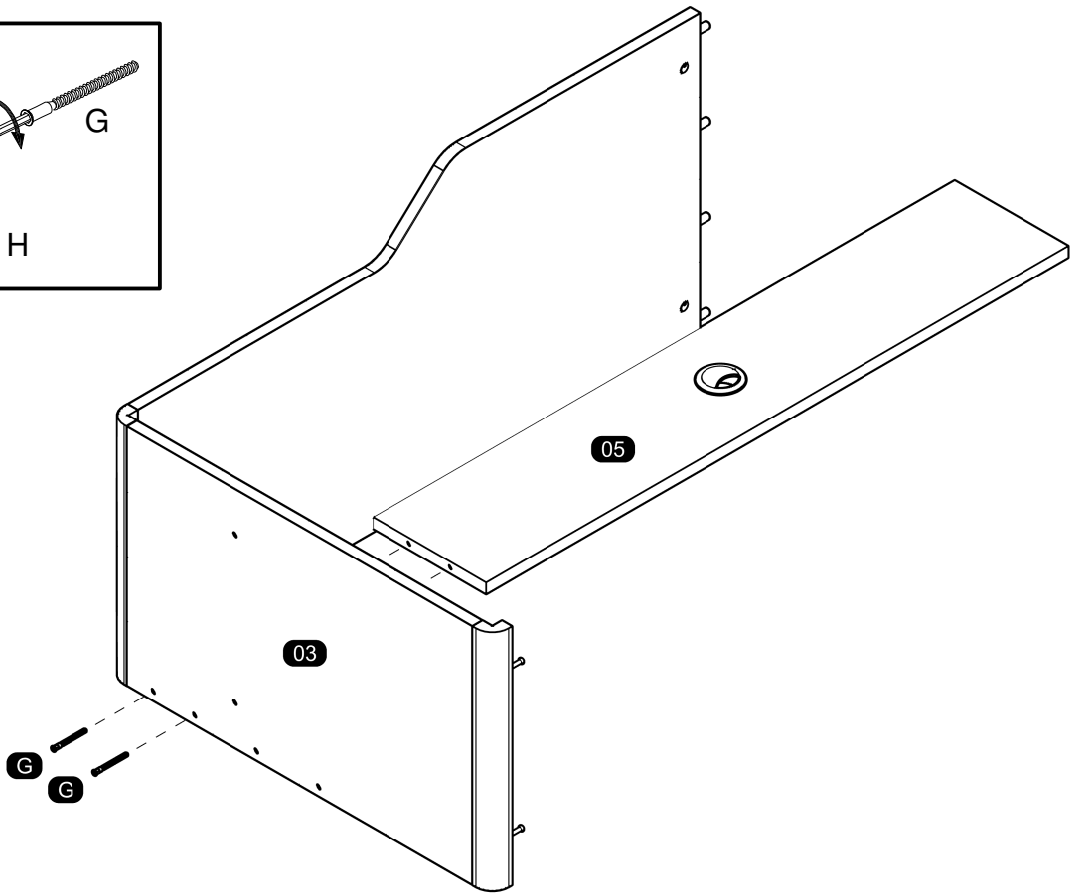
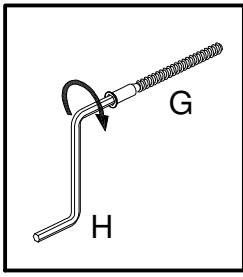

07

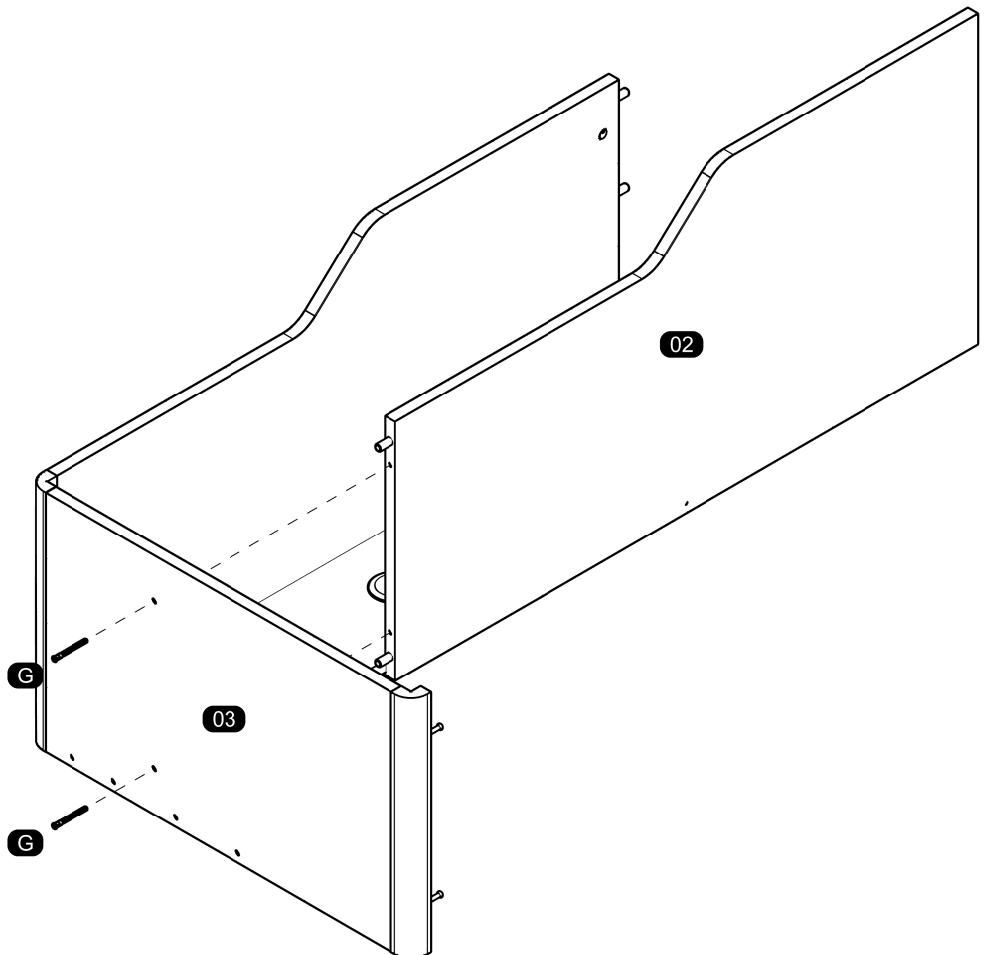

08

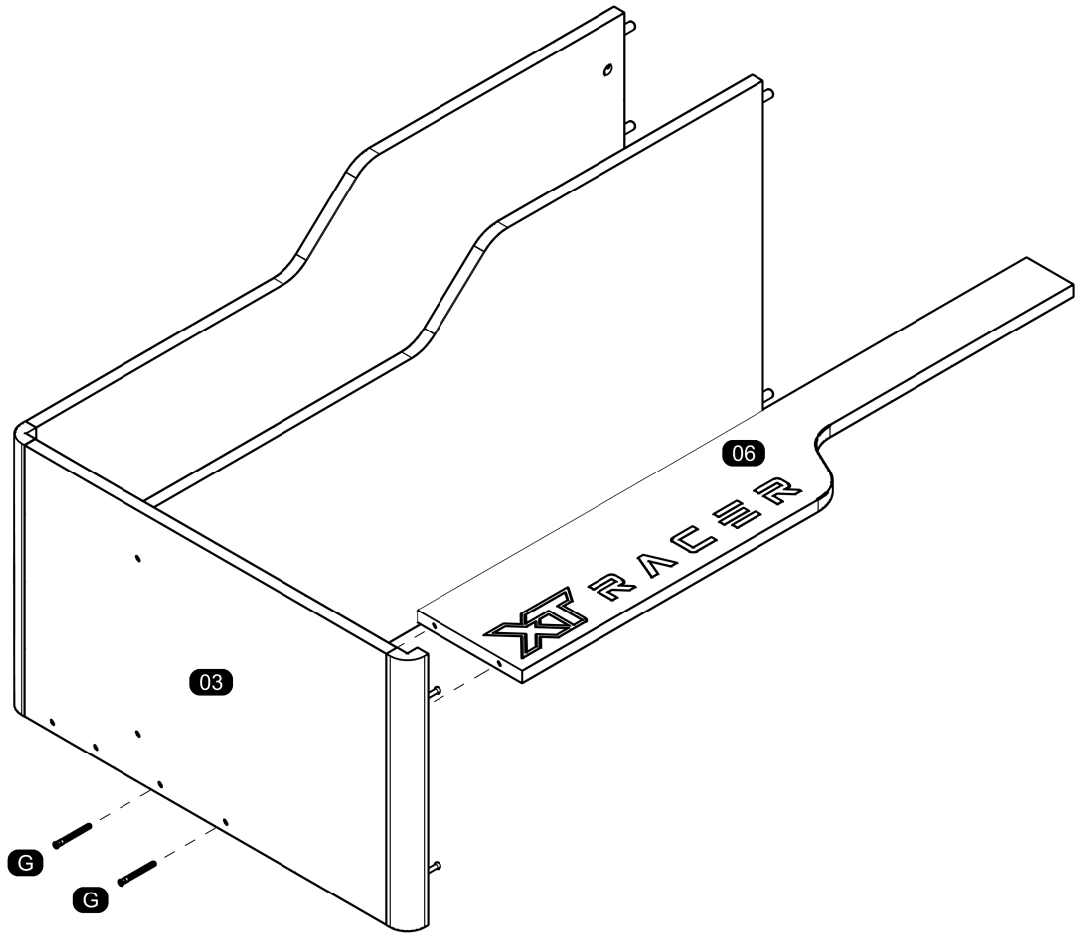

09

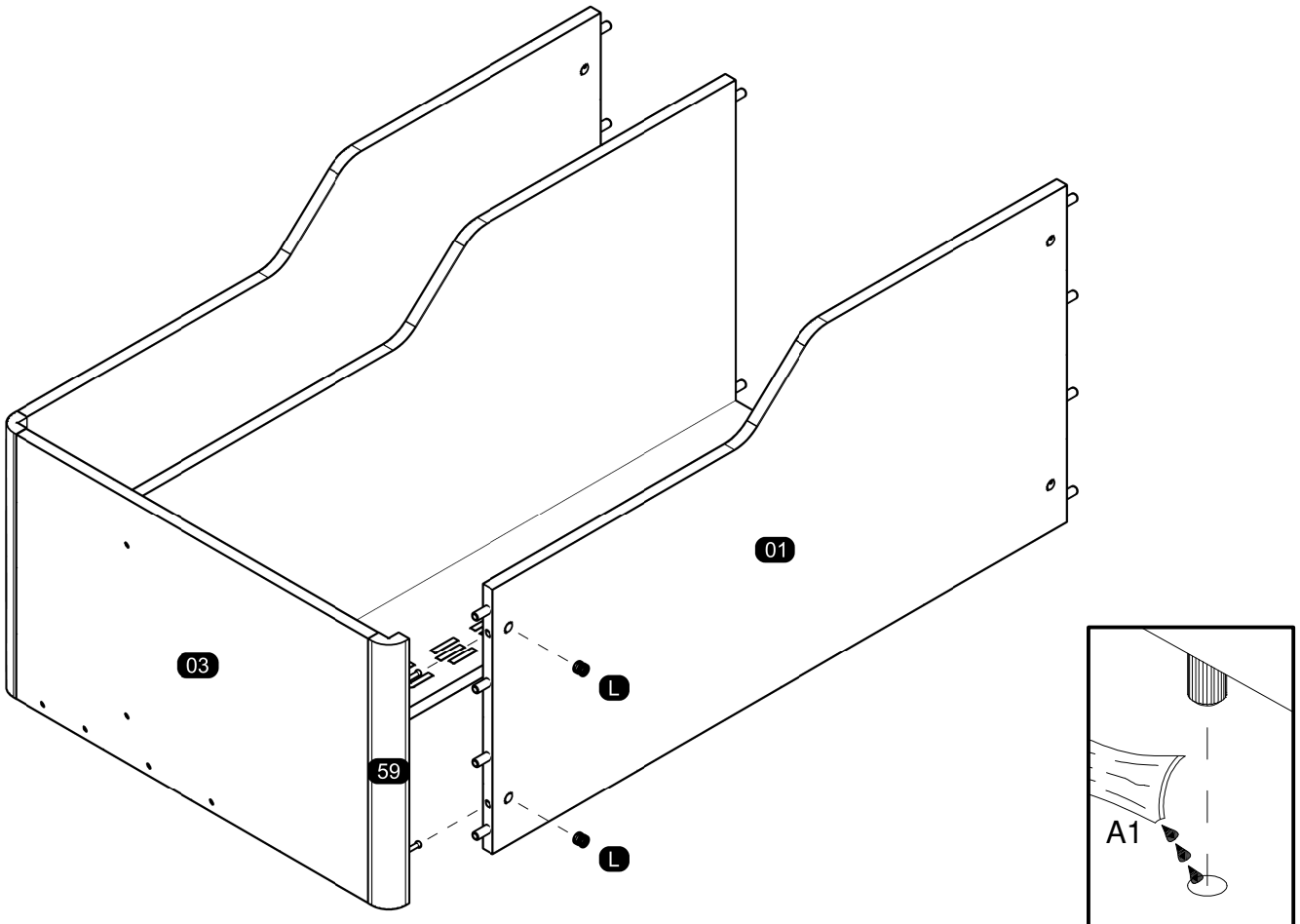

10

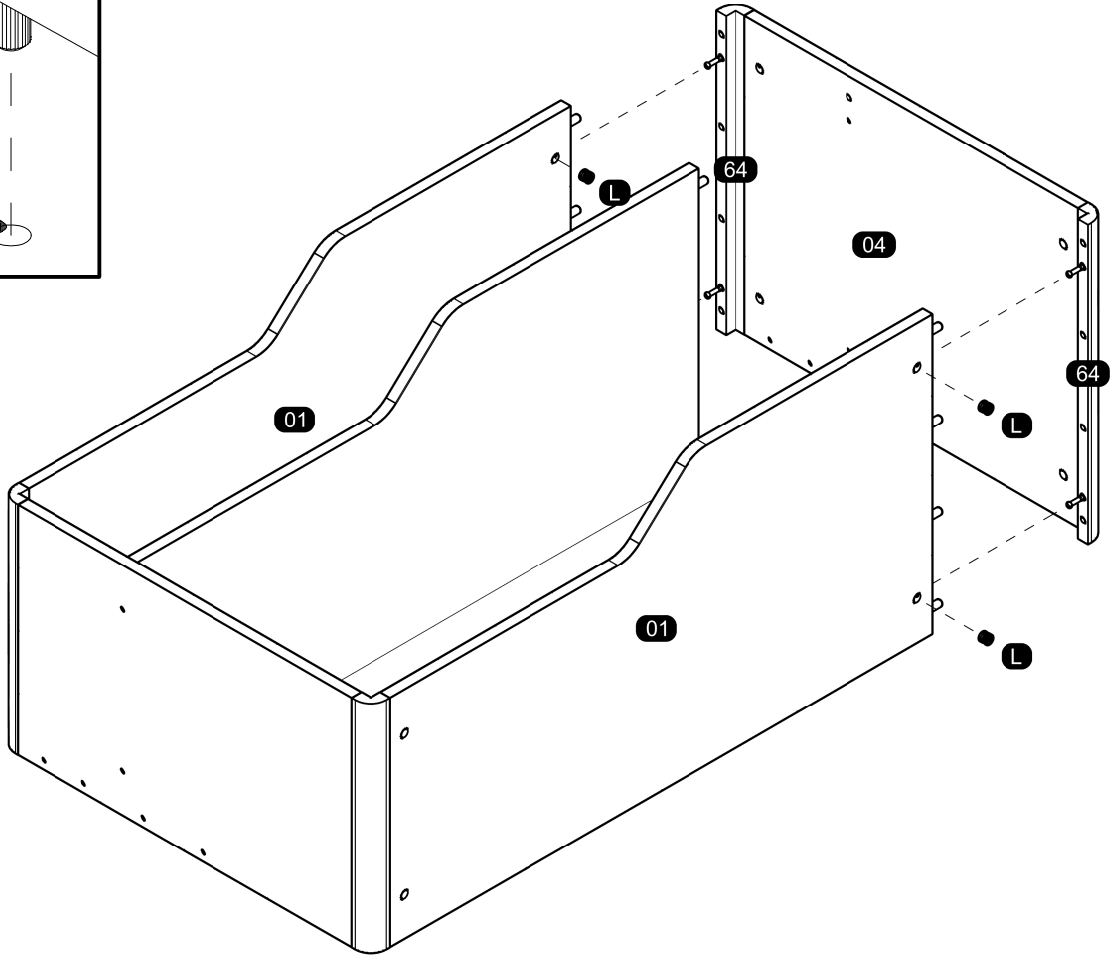
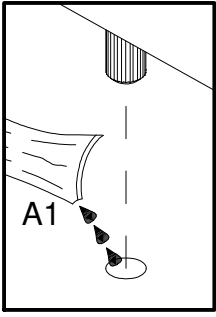

11

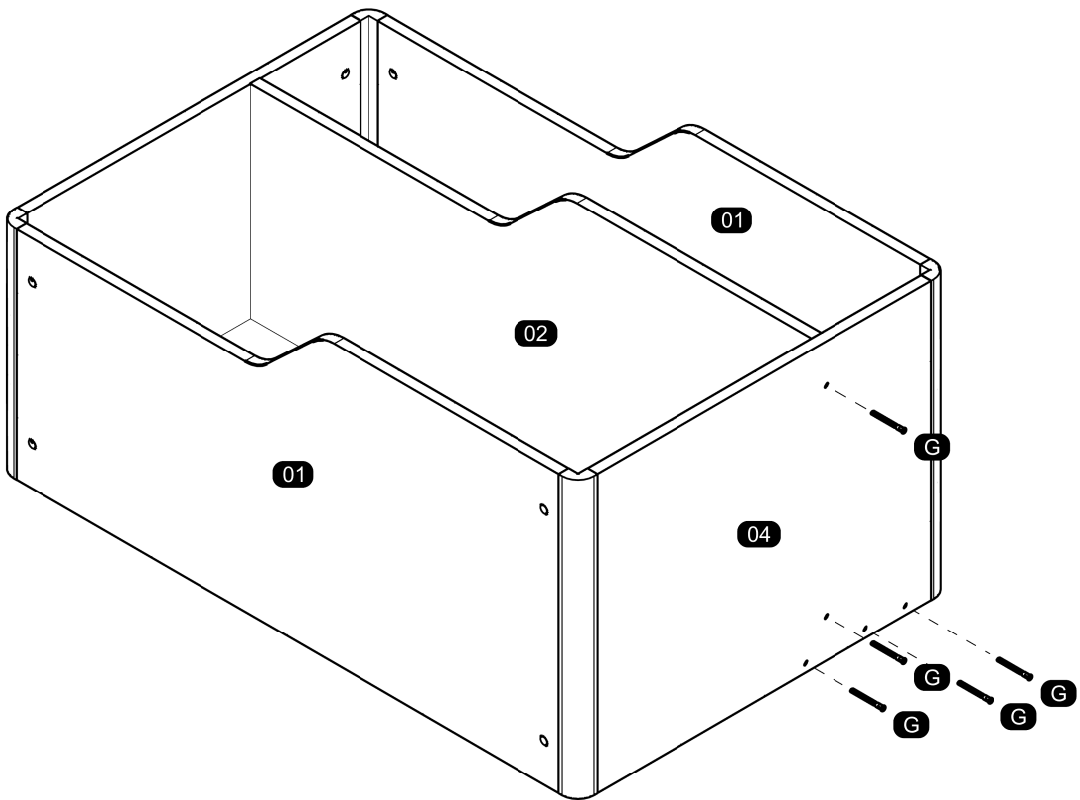

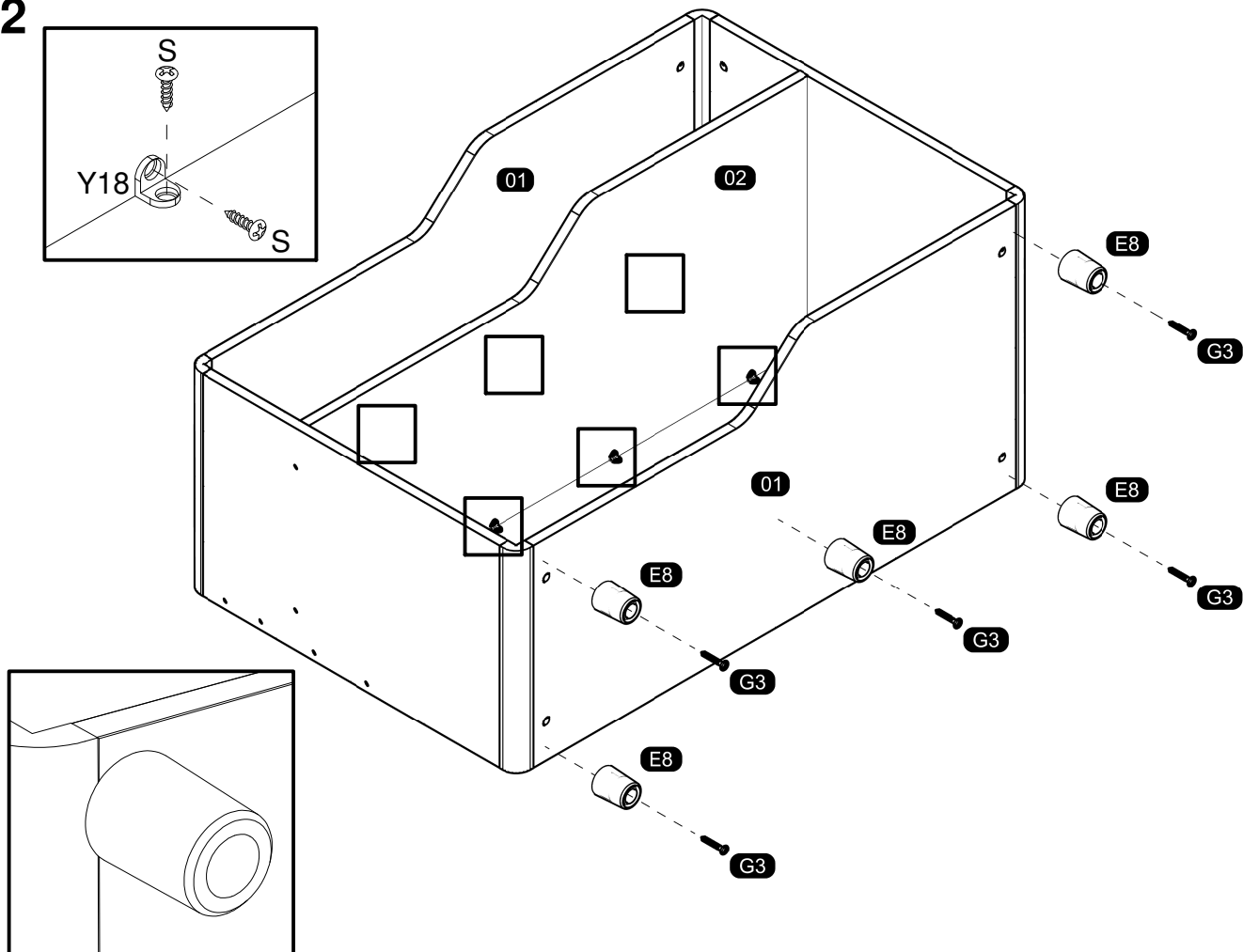
12**13**

At the end of the assembly, insert the screw cover / hole plugs in the apparent holes.
 Ao final da montagem, insira a(s) tampa(s) de parafuso / tampa furos nos furos que ficarem aparentes.
 Al final del conjunto, coloque la tapa tornillo / tapón plástico en los agujeros que se hagan evidentes.

