

# MANUAL DE MONTAGEM INSTRUCCIONES DE MONTAJE ASSEMBLY INSTRUCTIONS

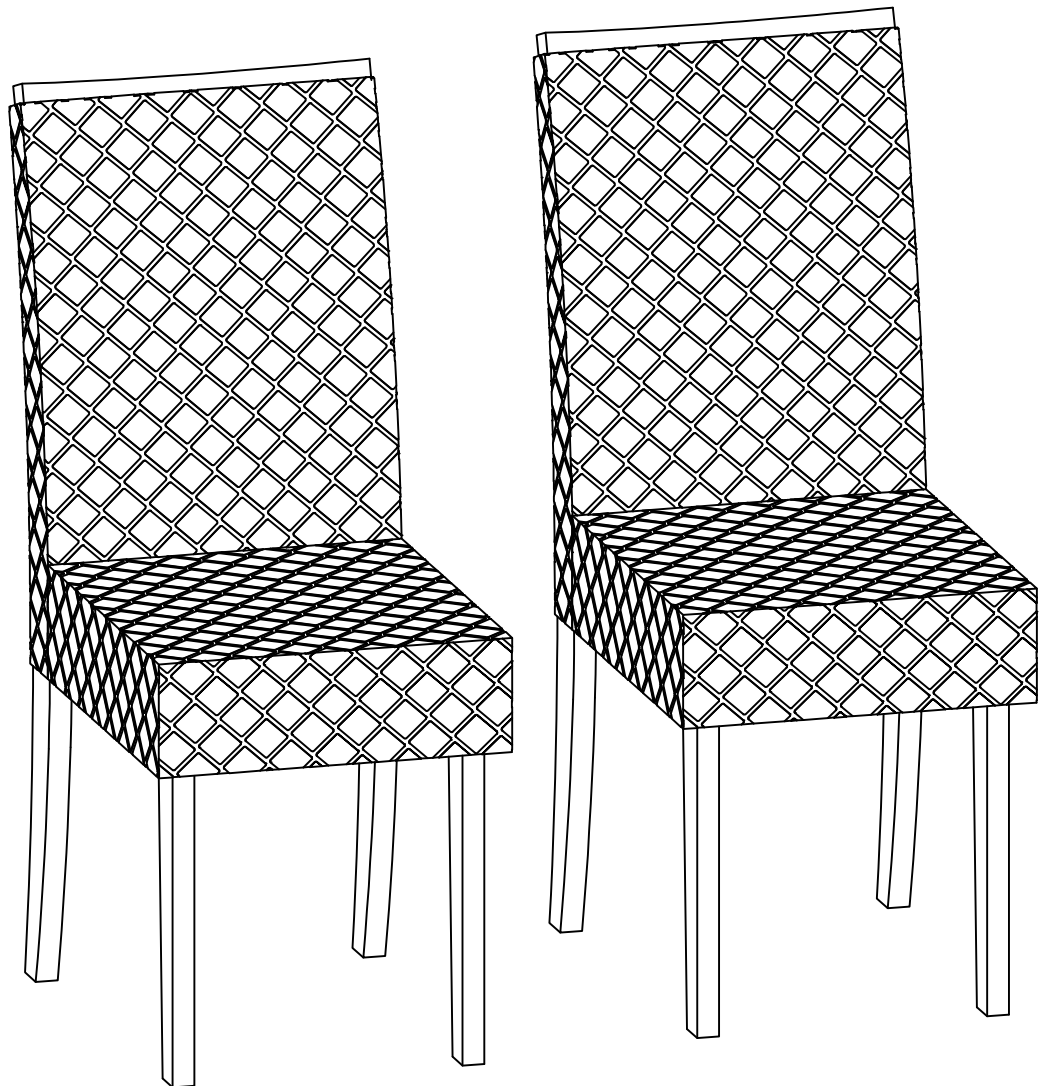

## ATENÇÃO / PRECAUCIÓN / ATTENTION:

- 1 – Ler atentamente todo o manual antes de iniciar a montagem do móvel.
- 2 – A montagem deve ser feita em uma superfície plana e limpa.
- 3 – Recomenda-se utilizar a embalagem do móvel para forrar e chão e assim não danificá-lo.
  - 1 – Lea cuidadosamente todo el manual antes de comenzar el montaje.
  - 2 – La instalación debe hacerse sobre una superficie plana y limpia.
  - 3 – Recomanda ser utilizado para empaquetar móvel a la línea y tierra y por lo tanto dañar ellos.
- 1 – Read the entire manual carefully before starting the furniture assembly.
- 2 – The assembly must be done on a flat and clean surface.
- 3 – It is recommended to use the packaging of the furniture to cover and floor and thus not to damage them.

## LIMPEZA E CONSERVAÇÃO / LIMPIEZA Y CONSERVACIÓN / CLEANLINESS AND CONSERVATION:

A limpeza do móvel deve ser feita com utilização de pano umedecido com água, podendo conter uma pequena quantidade de álcool. Não utilize produtos abrasivos.

La unidad de limpieza se debe realizar con el uso de paño humedecido con agua y puede contener una pequeña cantidad de alcohol. No utilice productos abrasivos.

The furniture should be cleaned with a cloth dampened with water and may contain a small amount of alcohol. Do not use abrasive products.

## GARANTIA / GARANTÍA / WARRANTY:

90 dias para defeitos de fabricação.

90 días a defectos de fabricación.

90 days for manufacturing defects.

## FERRAMENTAS NECESSÁRIAS / HERRAMIENTAS NECESARIAS / TOOLS REQUIRED:

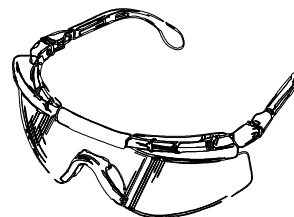
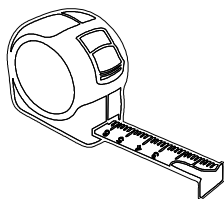
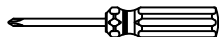

## FERRAMENTAS RECOMENDADAS / HERRAMIENTAS RECOMENDADAS / RECOMMENDED TOOLS:

Ponteira estilo philips

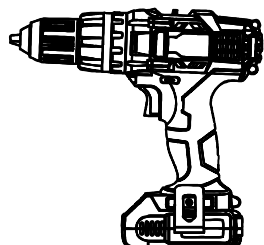
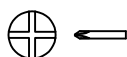

Acesse as dicas de montagem no Youtube

Accede a los consejos de montaje en Youtube.

Access the mounting tips on Youtube.

[www.youtube.com/MoveisKappesberg](http://www.youtube.com/MoveisKappesberg)



Lista de peças / Lista de piezas / List of pieces







Código/ Código/ Code	Descrição	Descripción	Description	Quantidade/ Cantidad/ Amount	Comprimento/ Longitud/ Length (mm)	Largura/ Ancho/ Width (mm)	Espessura/ Espesor/ Thickness (mm)	Caixa/ Caja/ Box
01	Encosto	Respaldo	Backrest	2	1005	435	55	A
02	Assento	Asiento	Seat	2	415	435	135	A

Para solicitar assistência técnica, utilize o código acima, no caso do encosto e assento, na nota deverá ser especificada a cor do tecido conforme a nota de compra.

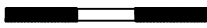
Para solicitar asistencia técnica, utilice el código arriba, en el caso del respaldo y asiento, en la nota deberá especificarse el color del tejido conforme a la nota de compra.

To request technical assistance, use the code above, in the case of the backrest and seat, the note must specify the color of the fabric according to the purchase note.

Ferragem / Herrajes / Hardware

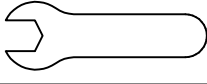
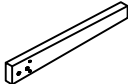
Código/ Código/ Code	Descrição / Descripción / Description	Quan./ Cant./ Amou.
A 50684	 Haste / Tornillo estructural/ Structural screw 90mm 1/4	4
B 50685	 Porca cilíndrica/ Tuerca del cilindro/ Cylinder nut 1/4	4
C 4214	 Parafuso chato/ Tornillo plano/ Flat screw 3,5x14	8
D 50686	 Arruela meia lua/ Arandela de media luna/ Half moon washer	4
E 40633	 Arruela lisa 1/4/ Arandela/ Washer	8
F 19959	 Porca sextavada/ Tuerca hexagonal/ Hexagon nut 1/4	12
G 45401	 Sapata deslizadora/ Zapata deslizante/ Slip shoe 20x4x4	8
H 50693	 Chave boca/ Llave de la boca/ Mouth key 1/4"	1
I 51546	 Pé baixo/ Pie bajo/ Low foot 441x60x25 MDF Freijo	4

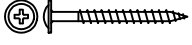
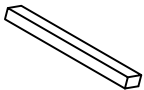
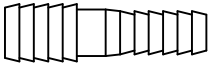
J 2592		Parafuso/ Tornillo/ Screw 4x40	12
K 60866		Puxador/ Manejar/ Handle Freijo	2
L 50687		Cavilha escalonada/ Clavija escalonada/ Stepped peg	4

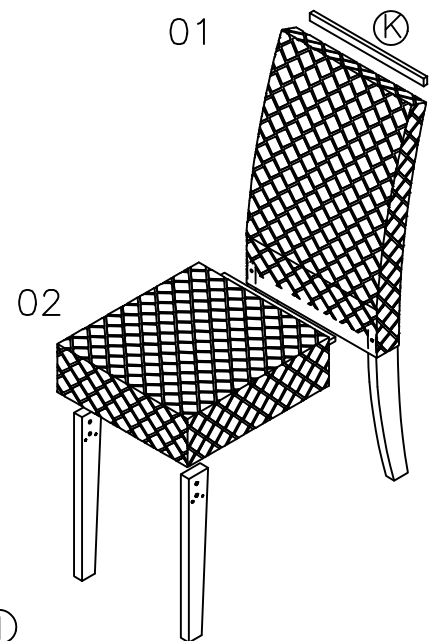

# #1

02

# 2CAD142FR

04/04

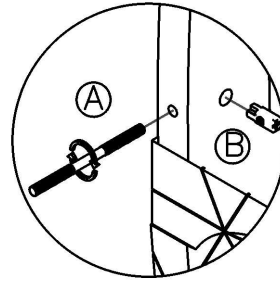
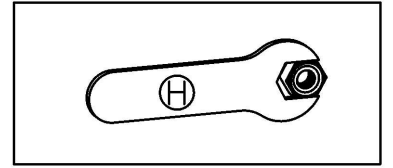
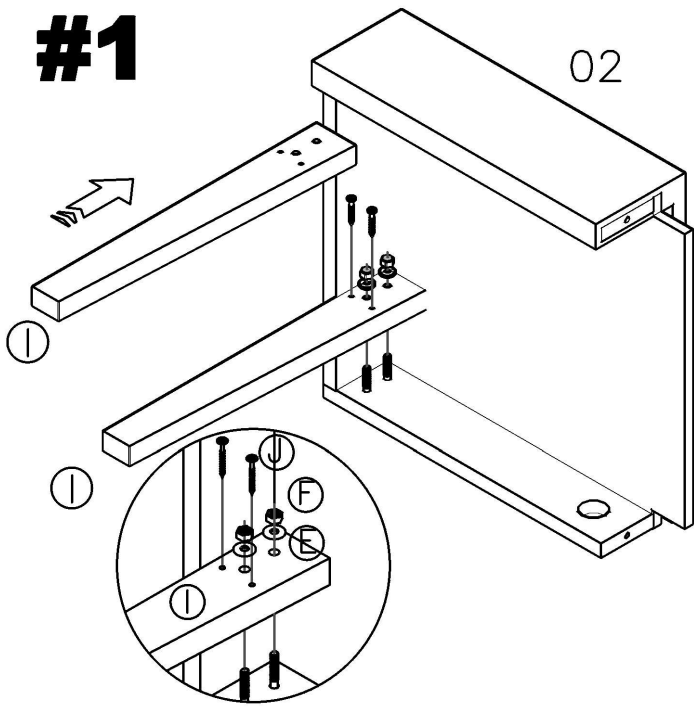

# #2

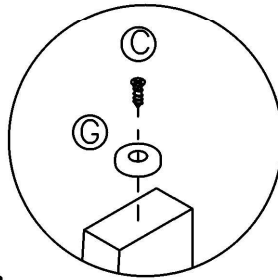
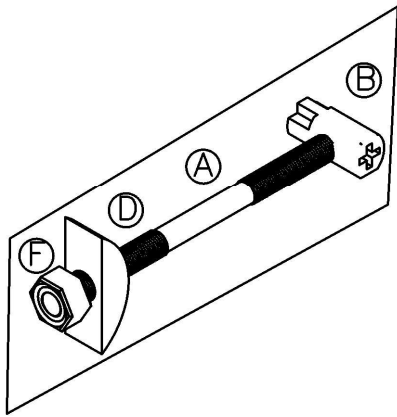
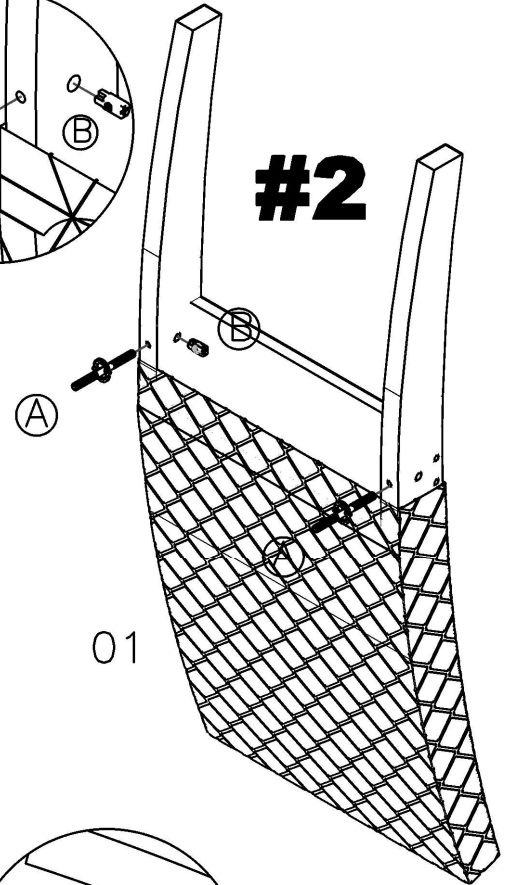

01

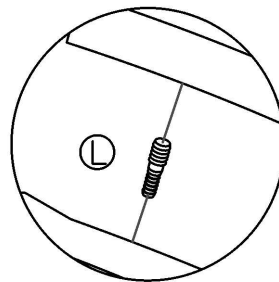

# #3

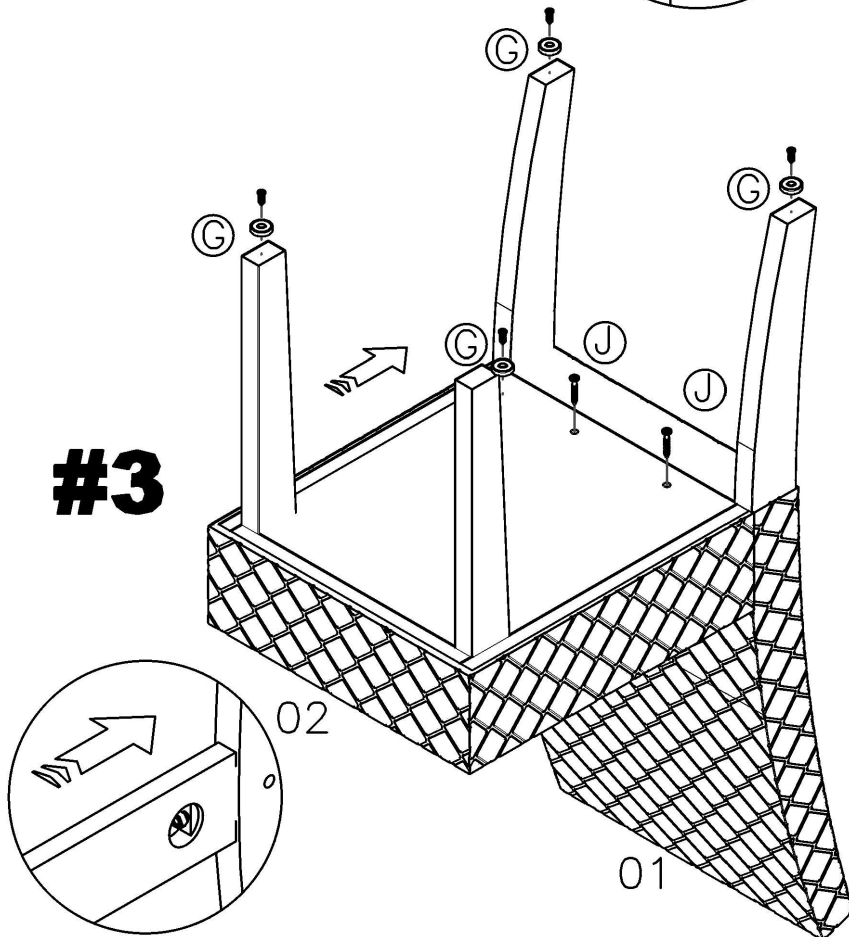

# #4

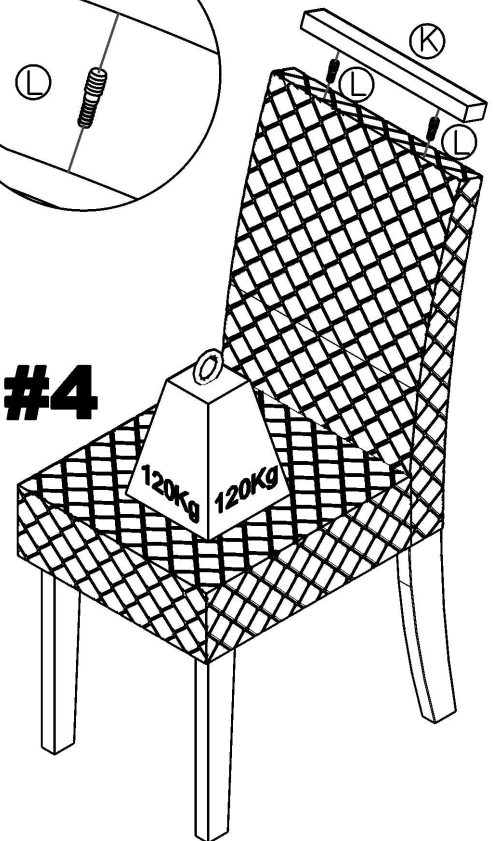

# MANUAL DE MONTAGEM

## INSTRUCCIONES DE MONTAJE

## ASSEMBLY INSTRUCTIONS

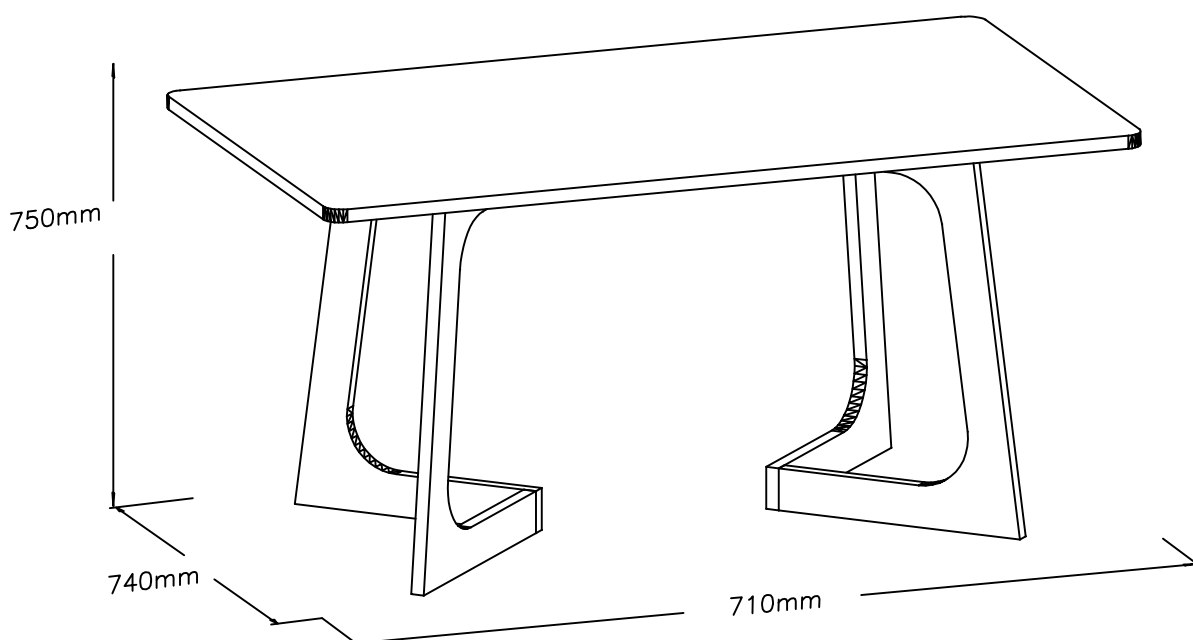

ATENÇÃO / PRECAUCIÓN / ATTENTION:

- 1 – Ler atentamente todo o manual antes de iniciar a montagem do móvel.
- 2 – A montagem deve ser feita em uma superfície plana e limpa.
- 3 – Recomenda-se utilizar a embalagem do móvel para forrar o chão e assim não danificá-lo.
  - 1 – Lea cuidadosamente todo el manual antes de comenzar el montaje.
  - 2 – La instalación debe hacerse sobre una superficie plana y limpia.
  - 3 – Recomanda ser utilizado para empaquetar móbil a la línea y tierra y por lo tanto dañar ellos.
- 1 – Read the entire manual carefully before starting the furniture assembly.
- 2 – The assembly must be done on a flat and clean surface.
- 3 – It is recommended to use the packaging of the furniture to cover the floor and thus not to damage them.

LIMPEZA E CONSERVAÇÃO / LIMPIEZA Y CONSERVACIÓN / CLEANLINESS AND CONSERVATION:

A limpeza do móvel deve ser feita com utilização de pano umedecido com água, podendo conter uma pequena quantidade de álcool. Não utilize produtos abrasivos.

La unidad de limpieza se debe realizar con el uso de paño humedecido con agua y puede contener una pequeña cantidad de alcohol. No utilice productos abrasivos.

The furniture should be cleaned with a cloth dampened with water and may contain a small amount of alcohol. Do not use abrasive products.

GARANTIA / GARANTÍA / WARRANTY:

90 dias para defeitos de fabricação.

90 días a defectos de fabricación.

90 days for manufacturing defects.

FERRAMENTAS NECESSÁRIAS / HERRAMIENTAS NECESARIAS / TOOLS REQUIRED:

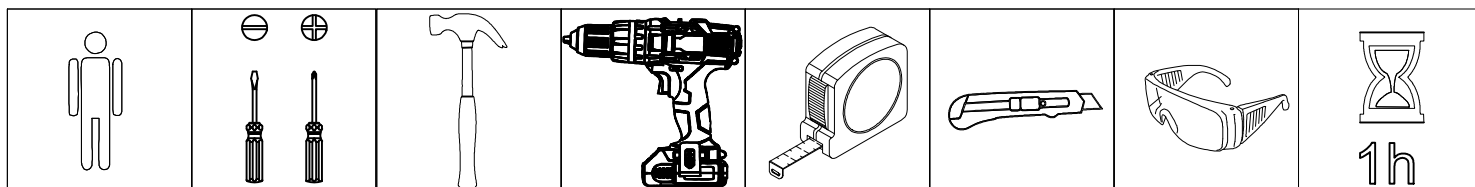

Acesse as dicas de  
montagem no Youtube

Accede a los consejos de  
montaje en Youtube.

Access the mounting tips on  
Youtube.





[www.youtube.com/MoveisKappesberg](http://www.youtube.com/MoveisKappesberg)

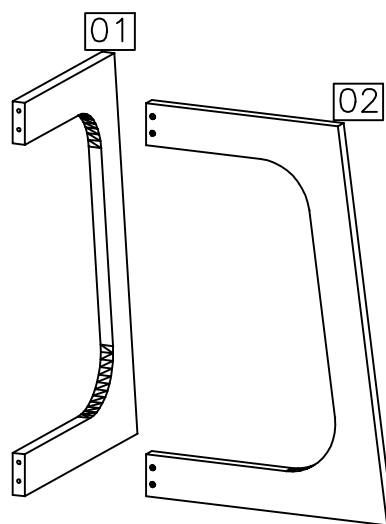
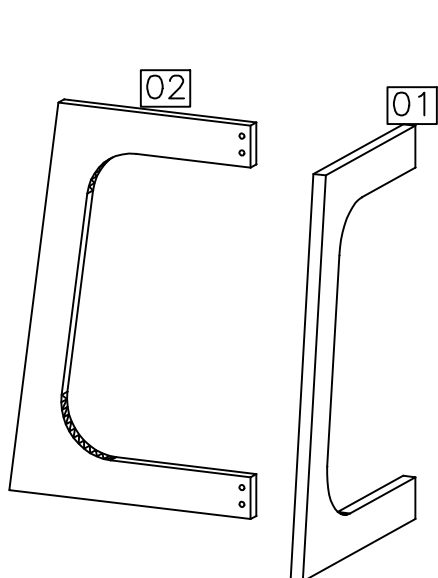
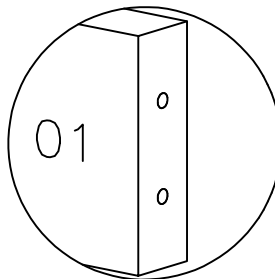
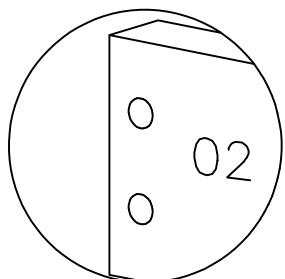

Lista de peças / Lista de piezas / List of pieces

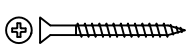
Código/ Código/ Code	Descrição	Descripción	Description	Quantidade/ Cantidad/ Amount	Comprimento/ Longitud/ Length (mm)	Largura/ Ancho/ Width (mm)	Espessura/ Espesor/ Thickness (mm)	Caixa/ Caja/ Box
01	Pé direito da base	Pie derecho base	Base right foot	2	750	490	25	A
02	Pé esquerdo da base	Base del pie izquierdo	Base left foot	2	750	490	25	A



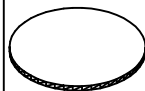
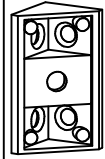

Ferragem / Herrajes / Hardware			
	Código/ Código/ Code	Descrição / Descripción / Description	Quan./ Cant./ Amou.
A	89	 Parafuso chato/ Tornillo plano/ Flat Screw 4,5x60	8
B	4214	 Parafuso/ Tornillo/ Screw 3,5X14	40
C	45401	 Sapata deslizadora/ Zapata deslizante/ Slip shoe 20x4x4	8
D	58	 Etiqueta marca/Tag label "Kappesberg"	1

E	WAF=44669 (Jacaranda) FR=51255 (Freijo)		Tapa furo/Tapa del agujero/Screw cap cover 13mm	8
F	899		Cantoneira /Cantonera /Ledge	8
01 Saco pequeno para acessórios				



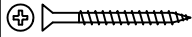

1

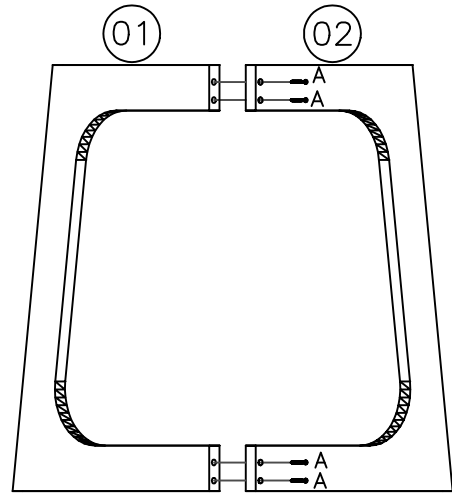
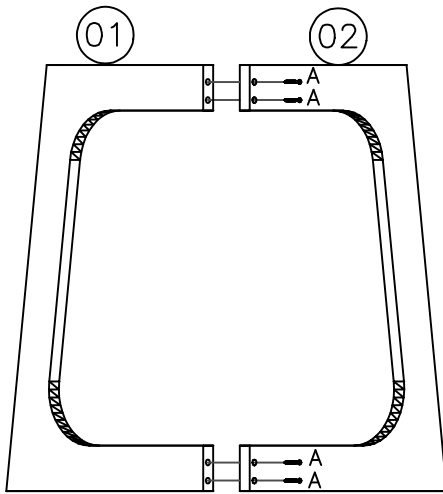
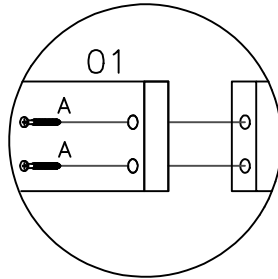
A		8
E		8



2

B		8
C		8

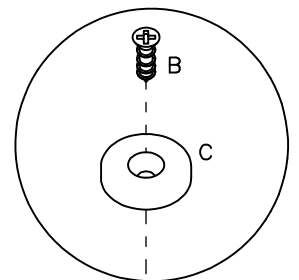
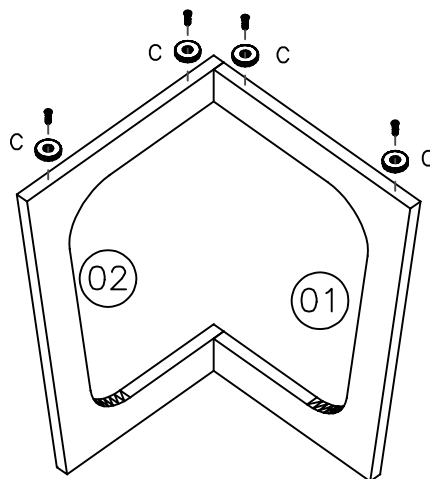
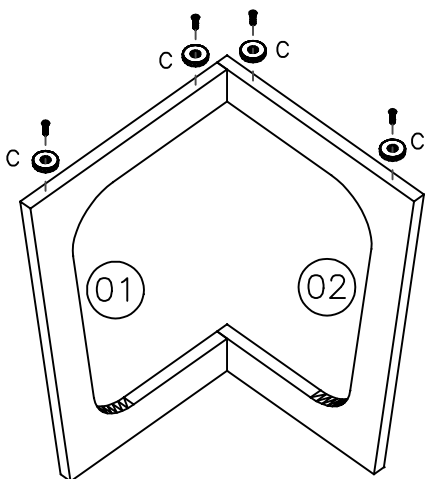



3

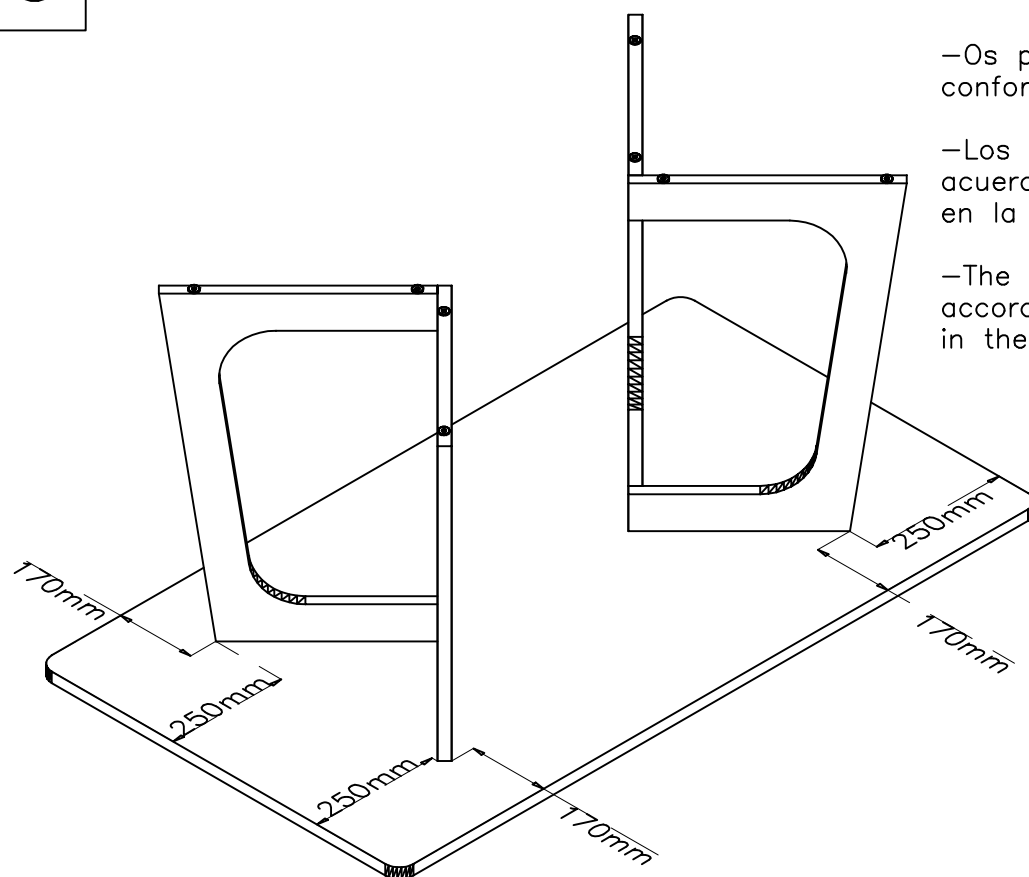



–Os pés devem ser posicionados conforme as medidas na ilustração

–Los pies deben colocarse de acuerdo con las medidas indicadas en la ilustración.

–The feet must be positioned according to the measures indicated in the illustration.

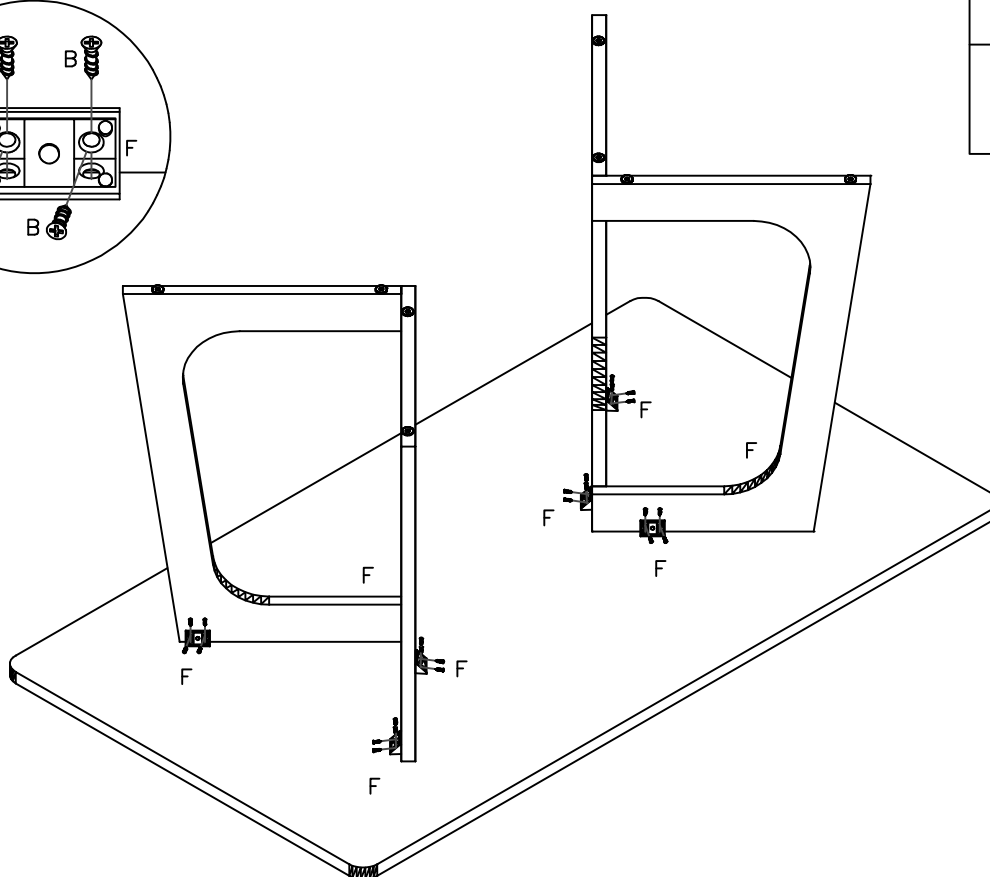
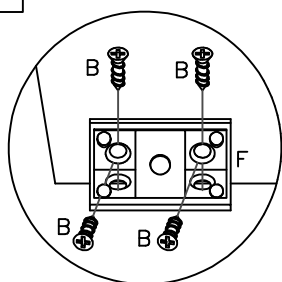
4

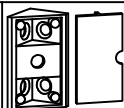

F		8
B		32

# MANUAL DE MONTAGEM

## INSTRUCCIONES DE MONTAJE

## ASSEMBLY INSTRUCTIONS

Lista de peças / Lista de piezas / List of pieces

Código/ Código/ Code	Descrição	Descripción	Description	Quantidade/ Cantidad/ Amount	Comprimento/ Longitud/ Length (mm)	Largura/ Ancho/ Width (mm)	Espessura/ Espesor/ Thickness (mm)	Caixa/ Caja/ Box
01	Tampo	Tapa del mesa	Table top	1	1600	900	25	A
WAFV4=51556	Vidro Bronze	Vidrio Bronze	Glass Bronze	1	1598	898	3	A
WAFV5=51604	Vidro Inox	Vidrio Inox	Glass Inox	1	1598	898	3	A
WAFV6=51605	Vidro Pedra	Vidrio Pedra	Glass Pedra	1	1598	898	3	A
FRV4=51556	Vidro Bronze	Vidrio Bronze	Glass Bronze	1	1598	898	3	A
FRV5=51604	Vidro Inox	Vidrio Inox	Glass Inox	1	1598	898	3	A
FRV6=51605	Vidro Pedra	Vidrio Pedra	Glass Pedra	1	1598	898	3	A
FRV9=64253	Vidro Freijo	Vidrio Freijo	Glass Freijo	1	1598	898	3	A
PRFV7=52563	Vidro Preto	Vidrio Negro	Glass Black	1	1598	898	3	A
OWV8=55465	Vidro Off white	Vidrio Off white	Glass Off white	1	1598	898	3	A

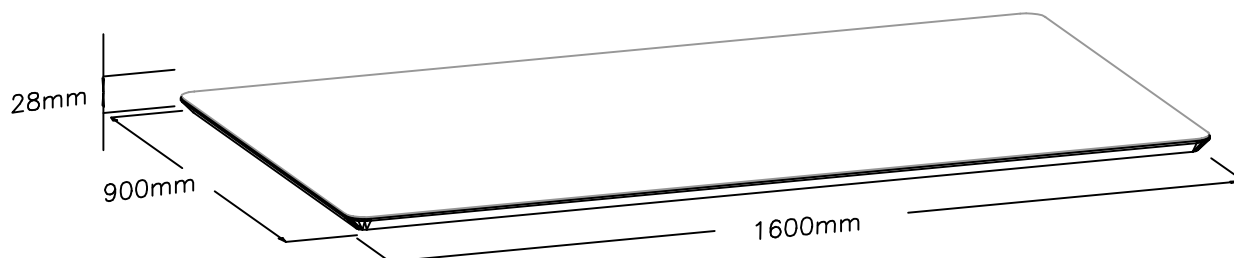

## ATENÇÃO / PRECAUCIÓN / ATTENTION:

- 1 – Ler atentamente todo o manual antes de iniciar a montagem do móvel.
- 2 – A montagem deve ser feita em uma superfície plana e limpa.
- 3 – Recomenda-se utilizar a embalagem do móvel para forrar e chão e assim não danificá-lo.
  - 1 – Lea cuidadosamente todo el manual antes de comenzar el montaje.
  - 2 – La instalación debe hacerse sobre una superficie plana y limpia.
  - 3 – Recomanda ser utilizado para empaquetar móvel a la línea y tierra y por lo tanto dañar ellos.
- 1 – Read the entire manual carefully before starting the furniture assembly.
- 2 – The assembly must be done on a flat and clean surface.
- 3 – It is recommended to use the packaging of the furniture to cover and floor and thus not to damage them.

## LIMPEZA E CONSERVAÇÃO / LIMPIEZA Y CONSERVACIÓN / CLEANLINESS AND CONSERVATION:

A limpeza do móvel deve ser feita com utilização de pano umedecido com água, podendo conter uma pequena quantidade de álcool. Não utilize produtos abrasivos.

La unidad de limpieza se debe realizar con el uso de paño humedecido con agua y puede contener una pequeña cantidad de alcohol. No utilice productos abrasivos.

The furniture should be cleaned with a cloth dampened with water and may contain a small amount of alcohol. Do not use abrasive products.

## GARANTIA / GARANTÍA / WARRANTY:

90 dias para defeitos de fabricação.

90 días a defectos de fabricación.

90 days for manufacturing defects.

## FERRAMENTAS NECESSÁRIAS / HERRAMIENTAS NECESARIAS / TOOLS REQUIRED:

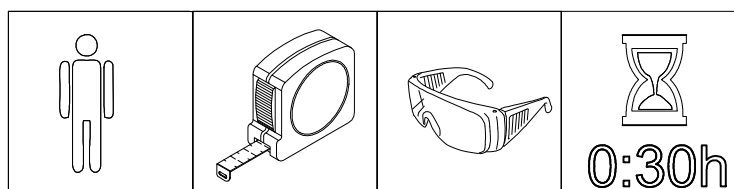

Acesse as dicas de  
montagem no Youtube

Accede a los consejos de  
montaje en Youtube.

Access the mounting tips on  
Youtube.

[www.youtube.com/MoveisKappesberg](http://www.youtube.com/MoveisKappesberg)

S:\Arquivos importantes\NÃO APAGAR.png

