

# MÖBLER®

## FICHA TÉCNICA / HOJA TECNICA / TECHNICAL SHEET

### 2001122 - HOME SUSP. SEUL

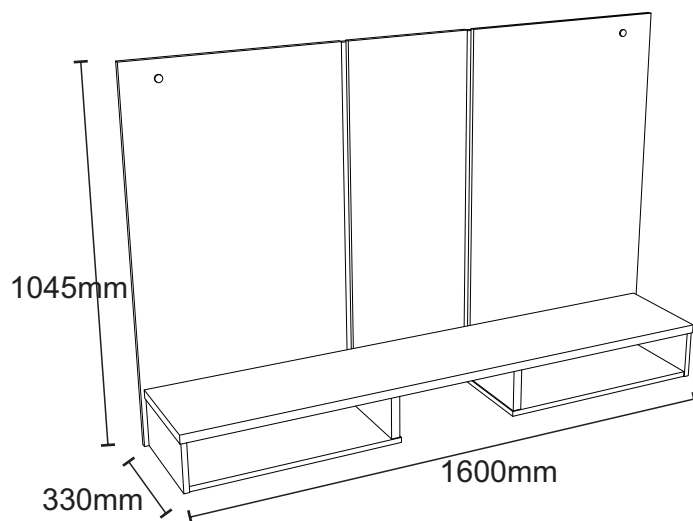

1 hora.

#### Para montagem:

For mounting / Para el montaje:

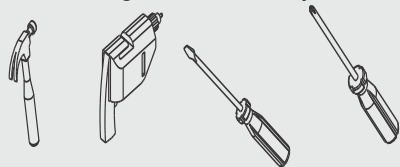

Nº	DESCRIÇÃO		TECA SUPREMO	NOCE ESPLENDOR	MAT. PRIMA	MEDIDAS				QTD.	
			OFF ÁRTICO	OFF ÁRTICO		(mm)					
21	TAMPO	TAPA	726	726	MDP M6B PRINT	1580	x	300	x	25	1
		COVER									
22	PAINEL ESQ.	PANEL IZQUIERDO	727	728	MDP M6B PRINT	1045	x	600	x	15	1
		LEFT PANEL									
23	PAINEL DIR.	PANEL DERECHO	727	728	MDP M6B PRINT	1045	x	600	x	15	1
		RIGHT PANEL									
24	PAINEL CENTRAL	PANEL CENTRAL	727	728	MDP M6B PRINT	1045	x	300	x	15	1
		CENTRAL PANEL									
25	TRAVESSA INT.	PLACA INTERNA	726	726	MDP M6B PRINT	910	x	100	x	15	2
		INTERNAL PLATE									
27	LAT. ESQ/ DIR.	LATERAL IZQUIERDA/ DERECHA	727	728	MDP M6B PRINT	297	x	140	x	15	2
		LEFT / RIGHT SIDE									
28	DIVISÃO	DIVISIÓN	726	726	MDP M6B PRINT	291	x	125	x	15	2
		DIVISION									
29	PRATELEIRA	ESTANTE	727	728	MDP M6B PRINT	597	x	292	x	15	2
		SHELF									
30	TRAVESSA EXT	PLACA EXTERNA	727	728	MDP M6B PRINT	910	x	100	x	15	2
		EXTERNAL PLATE									

#### LEGENDA DE CORES

726 - OFF ÁRTICO	ÁRTICO OFF ARTIC	727 - TECA SUPREMO	TECA SUPREMO SUPREME TEAK	728 - NOCE ESPLENDOR	NOCE ESPLENDOR NOCE SPLENDOR
------------------	---------------------	-----------------------	------------------------------	-------------------------	---------------------------------

**2001122 - HOME SUSP. SEUL**

**Parabens você acaba de adquirir um produto MÖBLER. Você tem a sua disposição que há de melhor em qualidade e design.**

Congratulations you have just purchased a Möbler product. You have at your disposal the best in quality and design. Felicitaciones, acaba de comprar un producto Möbler. Tienes a tu disposición lo mejor en calidad y diseño.

Rua Floresta, Nº 08 - Jardim Santa Terezinha - Fone (0\*\*43) 3242 - 8800 - Bela Vista do Paraíso - Paraná - [www.mobler.ind.br](http://www.mobler.ind.br)

# DESCRIÇÃO DE ACESSÓRIOS

CÓD.	DESCRIÇÃO		QTD.	DESENHO
A	SACHÊ DE COLA	SACHÊ DE COLA STRAW OF TAIL	6	
B	CANTONEIRA ZAMAC	CANTONERA ZAMAC ZAMAC CORNER	8	
C	PARAFUSO 3,5 x 14mm	TORNILLO 3,5*14 SCREW 3,5*14	12	
D	PARAFUSO 4,0 x 25mm	TORNILLO 4,0*25 SCREW 4,0*25	56	
E	PARAFUSO 4,0 x 50mm	TORNILLO 4,0*50 SCREW 4,0*50	12	
F	PARAFUSO 5,0 x 70mm	TORNILLO 5,0*70 SCREW 5,0*70	5	
G	CAVILHA 6 X 30mm	BOLSILLO DE MADERA WOODEN POCKET	10	
H	BUCHA 8mm	CASQUILLO DE PARED WALL MOUNTED BUSH	6	
I	PARAFUSO P/ BUCHA	TORNILLO P/ BUCHA DUST BOLT	6	
J	BOTÃO DECORATIVO	BOTÓN DECORATIVO DECORATIVE BUTTON	6	
K	PASSA FIO 40mm	PASSA HILO WIRELESS	2	
L	PINO DE PRAT. 8x12	PINO DE PRATELERA 8x12mm SHELF PINE 8X12mm	8	
M	TAMPA DA CASTANHA	TAPA DE TAMBOR DRUM COVER	4	

# 1º Passo

B	CANTONEIRA ZAMAC	08	
C	PARAFUSO 3,5 x 14mm	16	
E	PARAFUSO 4,0 x 50mm	08	
G	CAVILHA 6 X 30mm	10	
M	TAMPA DA CASTANHA	04	

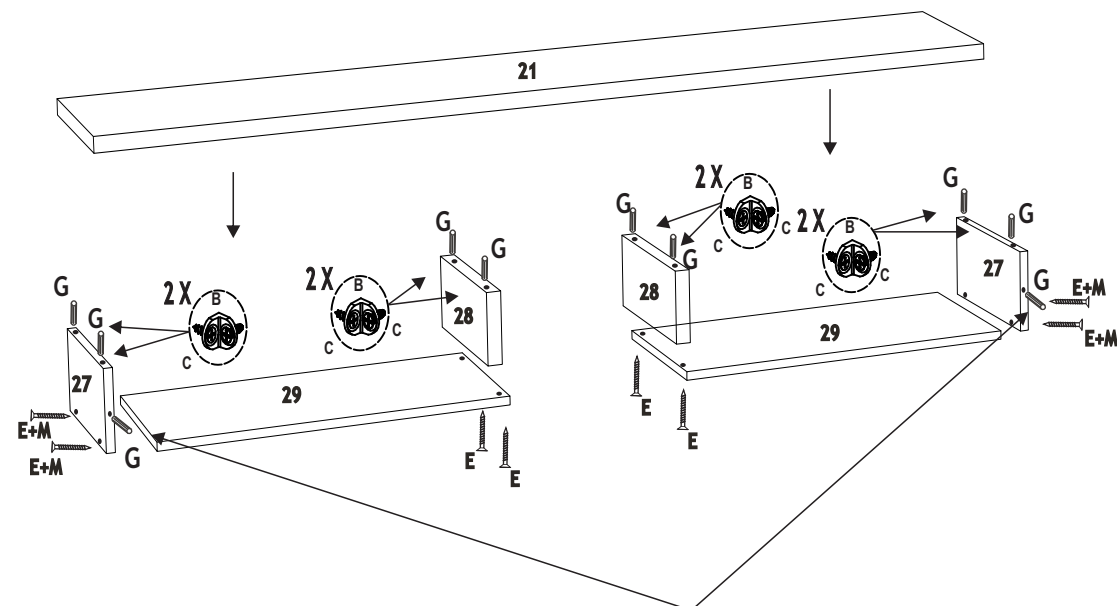

**SEGUIR A FURAÇÃO GUIA PARA FACILITAR A MONTAGEM**  
 SEGUIR LA FURACIÓN GUÍA PARA FACILITAR EL MONTAJE / FOLLOW THE DRILLING GUIDE TO FACILITATE THE ASSEMBLY

## 2º Passo

<b>A</b>	<b>SACHÊ DE COLA</b>	SACHÊ DE COLA STRAW OF TAIL	<b>02</b>	
<b>D</b>	<b>PARAFUSO 4,0 x 25mm</b>	TORNILLO 4,0*25 SCREW 4,0*25	<b>50</b>	
<b>L</b>	<b>PINO DE PRAT. 8x12</b>	PINO DE PRATELERA 8x12mm SHELF PINE 8X12mm	<b>08</b>	

OBS:

1 - ABRIR A PRÓPRIA EMBALAGEM FORRAR O CHÃO COM PAPELÃO, DEPOIS COMEÇAR O PROCESSO DE MONTAGEM DO PAINEL.

1 - ABRIR LA PROPIA EMBALAJE FORRAR EL CHÓN CON PAPEL, DESPUÉ DE COMERCIAL EL PROCESO DE MONTAJE DEL PAINEL.

1 - OPEN THE OWN PACKAGE TO GROUND THE GROUND WITH CARDBOARD, AFTER STARTING THE PANEL MOUNTING PROCESS.

2 - UTILIZAR A PEÇA Nº 30 PARA ALINHAR CONFORME O DESENHO AS PEÇAS Nº 22,23 E FIXAR COMO ACESSÓRIO D.

2 - UTILIZAR LA PIEZA Nº 30 PARA ALINHAR CONFORME EL DISEÑO DE LAS PIEZAS Nº 22, 23 DESPUÉSZAR CON EL ACCESORIO D.

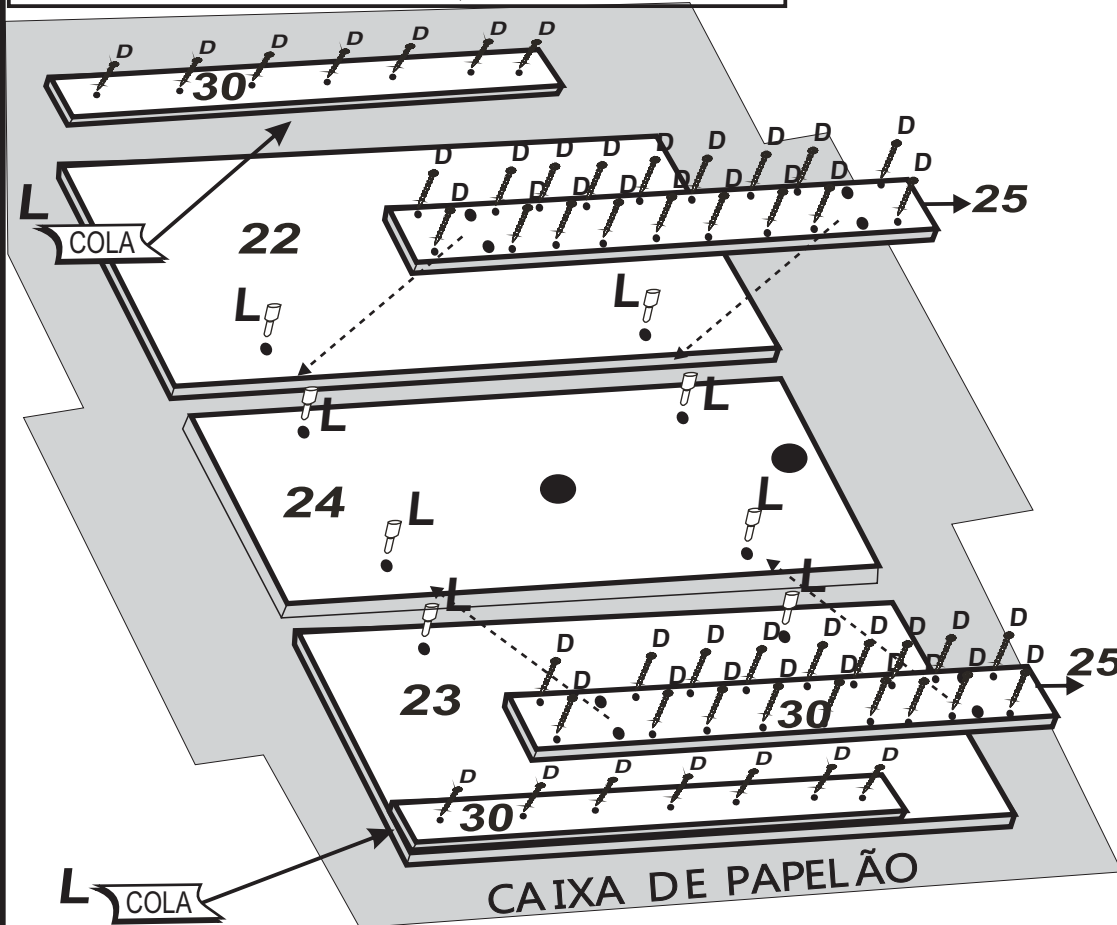

2 - USE PART Nº 30 TO ALIGN ACCORDING TOTHE DRAWING PARTS Nº 22, 23 FIX WITH THE ACCESSORY D.



**SEGUIR A MARCAÇÃO PARA FACILITAR A MONTAGEM  
SERÁ SEMPRE PARA ABAIXO.**

SEGUIR LA MARCA PARA FACILITAR EL MONTAJE / SERÁ SIEMPRE PARA ABAJO.  
FOLLOW THE MARKING TO FACILITATE THE ASSEMBLY / IT WILL ALWAYS BE BELOW.

## 3º Passo

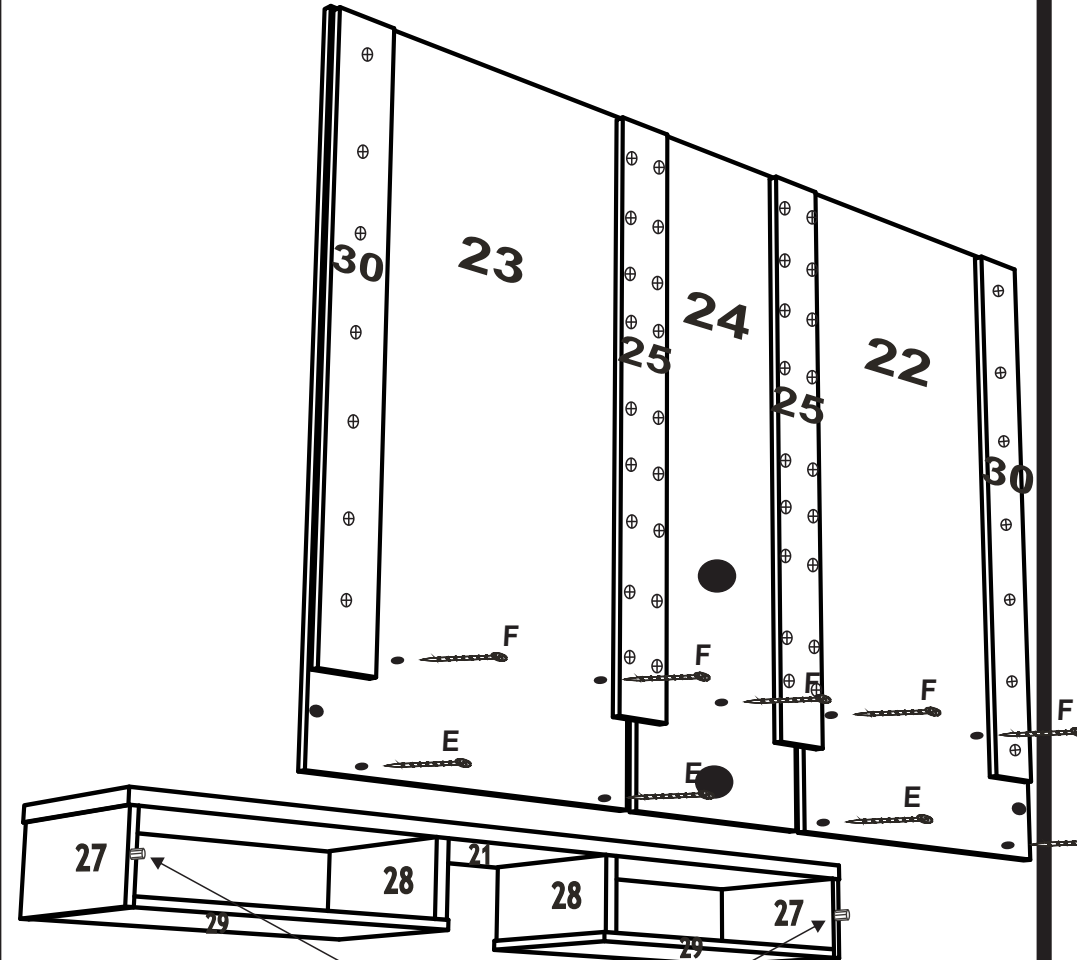

<b>E</b>	<b>PARAFUSO 4,0 x 50mm</b>	TORNILLO 4,0*50 SCREW 4,0*50	<b>04</b>	
<b>F</b>	<b>PARAFUSO 5,0 x 70mm</b>	TORNILLO 5,0*70 SCREW 5,0*70	<b>05</b>	



**SEGUIR A FURAÇÃO GUIA PARA A FACILITAR A MONTAGEM**

SEGUIR LA FURACIÓN GUÍA PARA FACILITAR EL MONTAJE / FOLLOW THE DRILLING GUIDE TO FACILITATE THE ASSEMBLY

# 4 ° Passo

H	BUCHA 8mm	CASQUILLO DE PARED WALL MOUNTED BUSH	06	
I	PARAFUSO P/ BUCHA	TORNILLO P/ BUCHA DUST BOLT	06	
J	BOTÃO DECORATIVO	BOTÓN DECORATIVO DECORATIVE BUTTON	06	
K	PASSA FIO 40mm	PASSA HILO WIRELESS	02	

## ATENÇÃO

ATTENTION / ATENCIÓN

## ALTURA SUGERIDA

SUGGESTED HEIGHT / ALTURA SUGERIDA

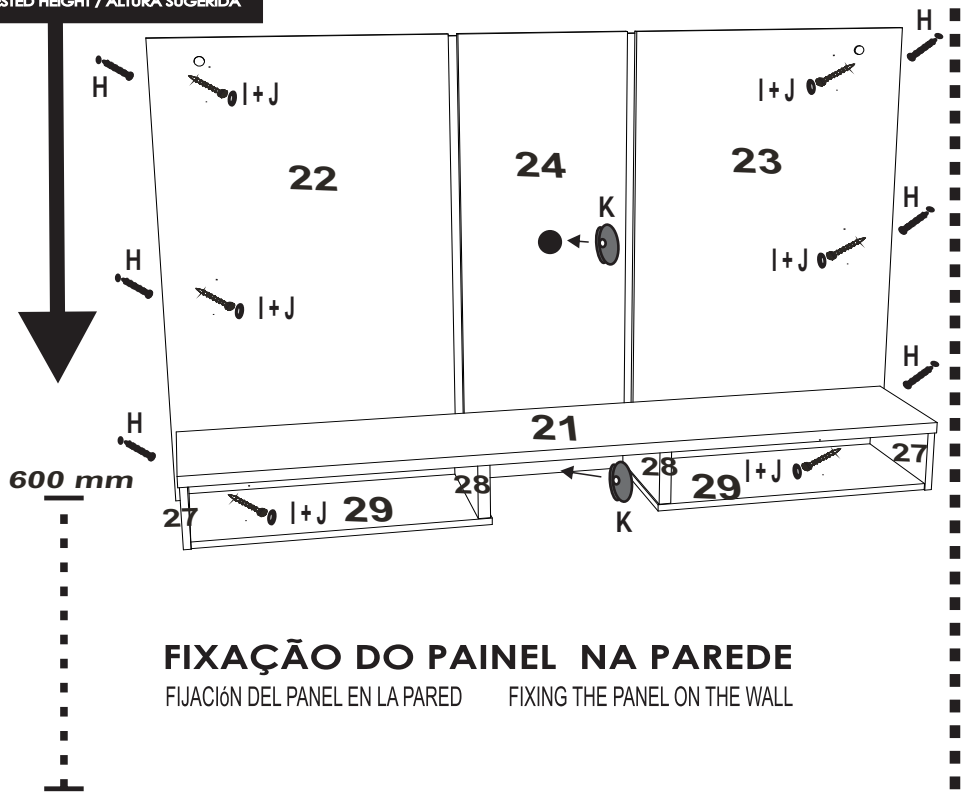

## FIXAÇÃO DO PAINEL NA PAREDE

FIJACIÓN DEL PANEL EN LA PARED    FIXING THE PANEL ON THE WALL

# IMAGEM EXPLODIDA

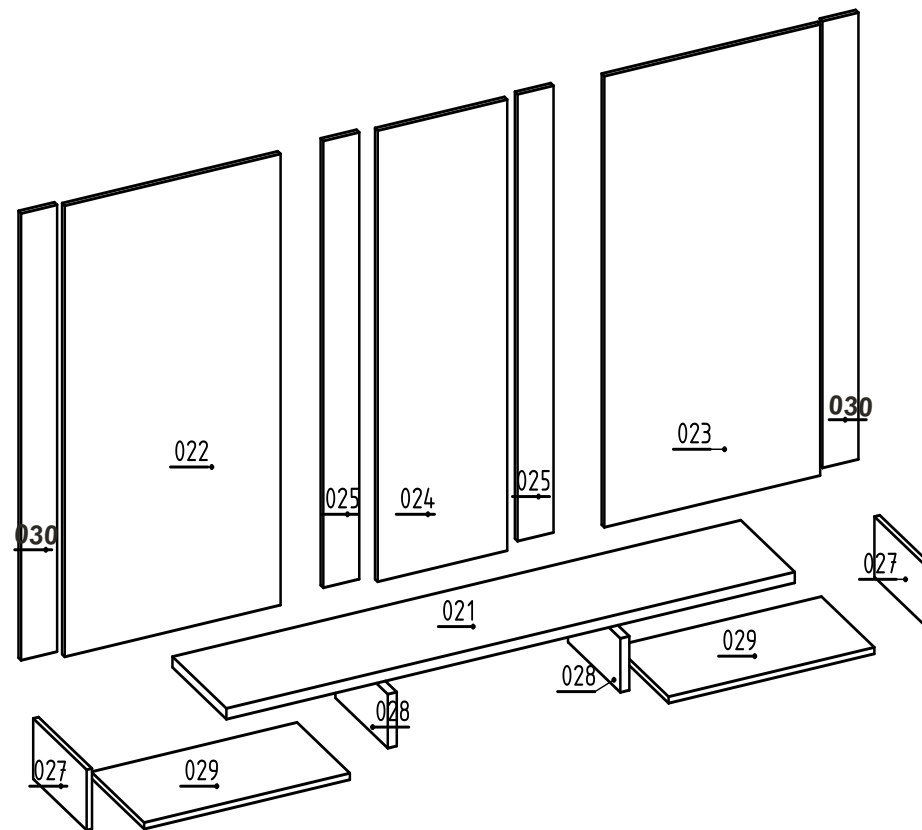

## OBSERVAÇÃO LIMPEZA:

A LIMPEZA DO M&B PRINT DEVE SER FEITA COM PANO LEVEMENTE UMEDECIDO COM ÁGUA E DETERGENTE NEUTRO. NUNCA DEVE-SE UTILIZAR PRODUTOS ABRASIVOS E PRODUTOS QUÍMICOS. OS PRINCIPAIS AGENTES MANCHADORES DO M&B PRINT SÃO: ACETONA, ÁLCOOL, ETÍLICO, MOSTARDA, DETERGENTE, DESINFETANTE, ÁGUA, CAFÉ SOLÚVEL, LEITE EM PÓ INTEGRAL, ÁCIDO ACÉTICO, PERÓXIDO DE HIDROGÊNIO, TINTA DE CANETA, TINTA DE PINCEL ATÔMICO, SOLUÇÃO DE AMÔNIA, BATOM VERMELHO, HIDRÓXIDO DE SÓDIO, HIPOCLORITO DE SÓDIO, PVPI, GRAXA DE SAPATO E ÁCIDO CÍTRICO.

LA LIMPIEZA DE LA IMPRESIÓN M&B SE DEBE REALIZAR CON UN COÁGULO DAÑADO CON AGUA Y DETERGENTE NEUTRO. NUNCA USE PRODUCTOS ABRASIVOS NI QUÍMICOS. LOS PRINCIPALES COLORANTES DE M&B PRINT SON: ACETONA, ALCOHOL, ETÍLICO, MOSTAZA, DETERGENTE, DESINFETANTE, AGUA, CAFÉ SOLUBLE, LECHE EN POLVO, ÁCIDO ACÉTICO, PERÓXIDO DE HIDRÓGENO, TINTA DE LÁPIZ, TINTA DE CEPILLO ATÔMICO, SOLUCIÓN DE AMONIACO, LÁPIZ LABIAL ROJO, HIDRÓXIDO DE SODIO, HIPOCLORITO DE SODIO, PVPI, Grasa DE CALZADO Y ÁCIDO CÍTRICO.

CLEANING THE M&B PRINT SHOULD BE CARRIED OUT WITH A CLOT WHICH IS DAMAGED WITH WATER AND NEUTRAL DETERGENT. NEVER USE ABRASIVE PRODUCTS AND CHEMICALS. THE MAIN STAINING AGENTS OF M&B PRINT ARE: ACETONE, ALCOHOL, ETHYLIC, MUSTARD, DETERGENT, DISINFECTANT, WATER, SOLUBLE COFFEE, WHOLE MILK POWDER, ACETIC ACID, HYDROGEN PEROXIDE, PEN INK, ATOMIC BRUSH INK, AMMONIA SOLUTION, RED LIPSTICK, SODIUM HYDROXIDE, SODIUM HYPOCHLORITE, PVPI, SHOE Grease AND CITRIC ACID.