

ATENÇÃO/ ATENCION/ ATTENTION

ESTE PRODUTO NÃO PODE SER ARRASTADO.
THIS PRODUCT MUSTNOT BE DRAGGED.
ESTE PRODUCTO NO SE PUEDE ARRASTRAR.

PEÇAS NUMERADAS/ NUMBERED PARTS/
PIEZAS NUMERADAS

EX: 1915X-X 10 (peça/ piece/ pieza number)

Ferramentas necessárias / Necessary tools / Herramientas Necesarias
(não fornecidas) (not provided) (No proporcionadas)



MONTAR O PRODUTO SOBRE A EMBALAGEM,
EVITANDO DANOS NA PINTURA.
ACONSELHAMOS QUE A MONTAGEM DO PRODUTO
SEJA POR UM PROFISSIONAL.

SETUP THE PRODUCT ON TOP OF THE PACKAGING, AVOIDING
DAMAGE TO THE PAINT.
WE RECOMMEND THAT THE INSTALLATION IS DONE BY
A PROFESSIONAL.

MONTAR EL PRODUCTO EN EL PAQUETE,
EVITAR LESIONES EN PINTURA.
AVISAMOS QUE EL MONTAJE DEL PRODUCTO
SEA UN PROFESIONAL.

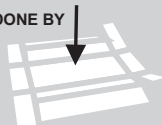

ATENÇÃO / ATTENTION / ATENCION

Nunca utilizar óleos, lustra móveis, produtos abrasivos, saponáceos, esponja de aço e outros.

Never use oils, furniture polish, abrasive products, soaps, steel sponge and others.

Nunca use aceites, pulimentos, abrasivos, jabones, esponja de acero y otros.

CUIDADOS ESPECIAIS/ SPECIAL CARE/ CUIDADOS ESPECIALES

- Evitar expor o móvel ao sol, e em lugares úmidos.
- Limpar com flanela seca ou com pano levemente umedecido em água.

- Avoid exposing the furniture to the sun, and in damp places.
- Clean with dry flannel or lightly cloth moistened with water.

- Evite exponer los muebles al sol y en lugares húmedos.
- Limpiar con flanela seca o un paño ligero, humedecido con agua.

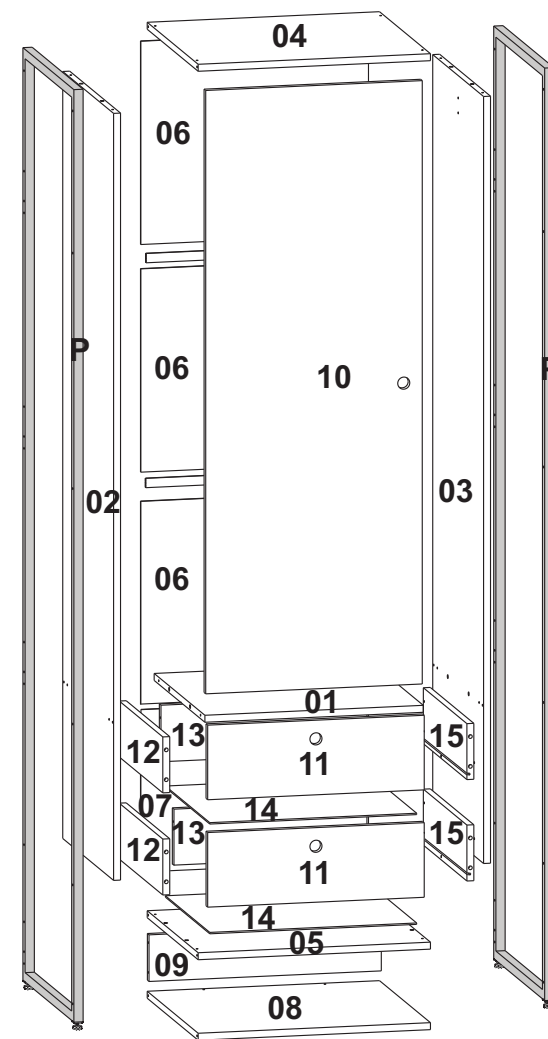
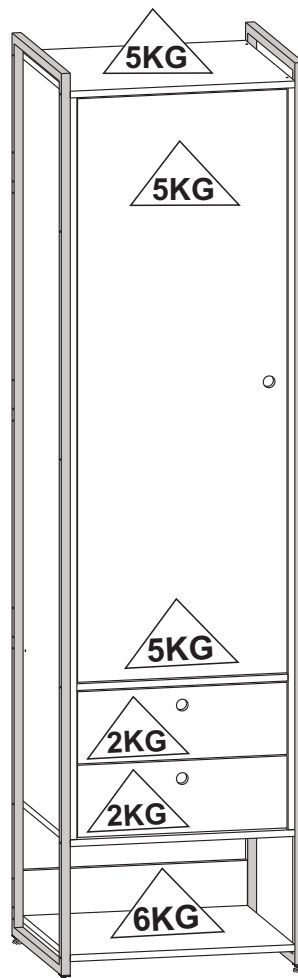

PREPARAÇÃO DE PEÇAS / PARTS PREPARATION / PREPARACION DE PIEZAS

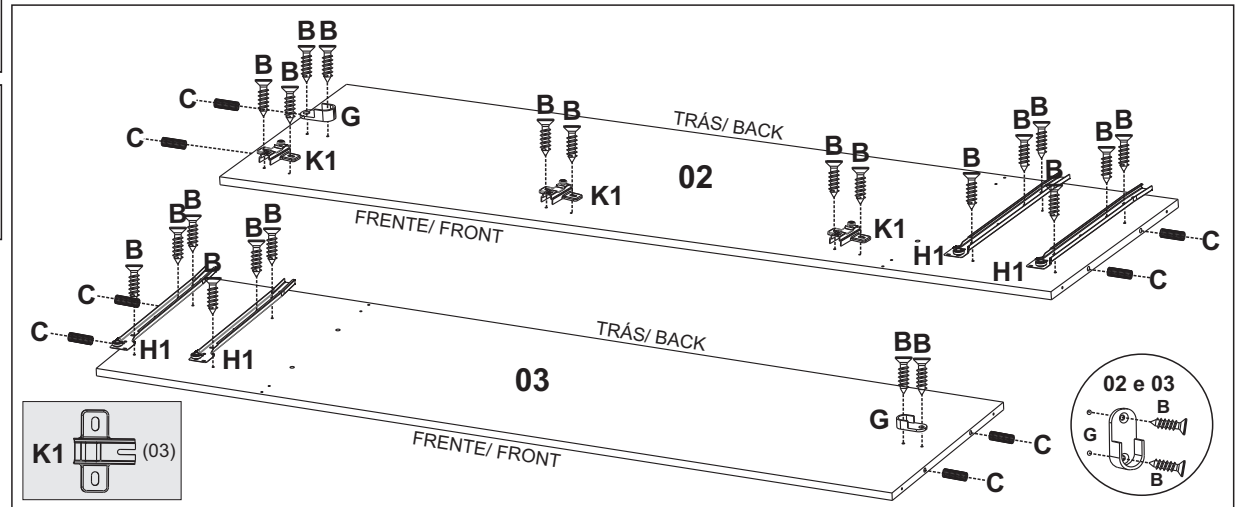
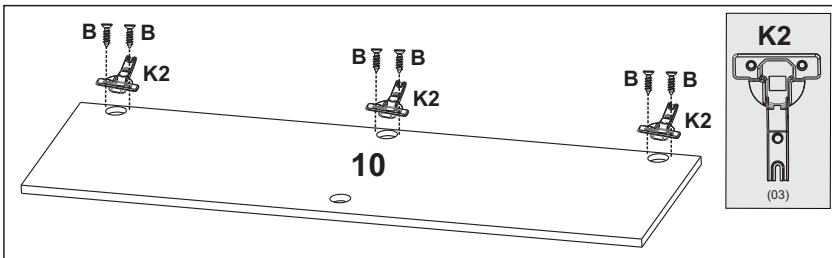
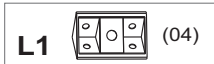
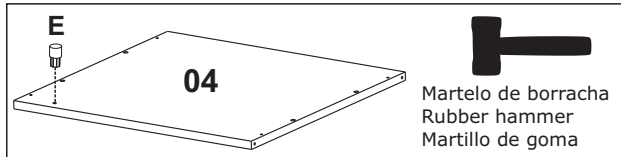
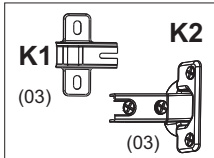
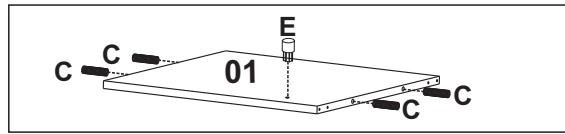
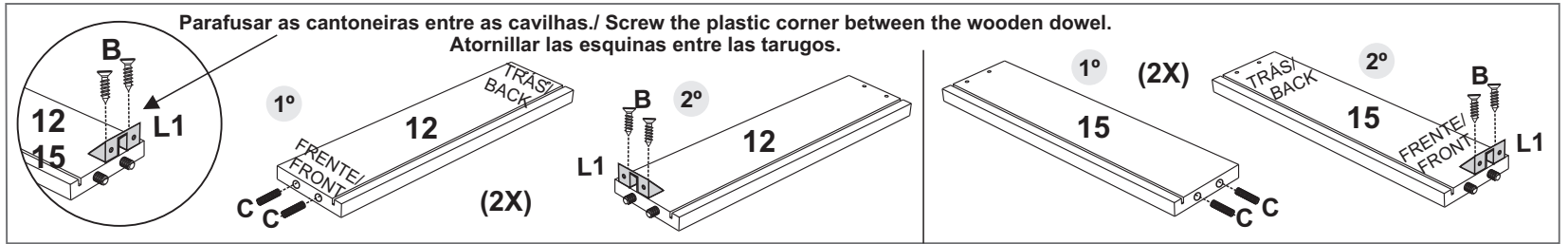

1 Obs: As peças pintadas nos passos são apenas ilustrativas. The parts painted in the steps are illustrative only. Las partes pintadas en los pasos son solo ilustrativas.

ATENÇÃO / ATTENTION / ATENCION

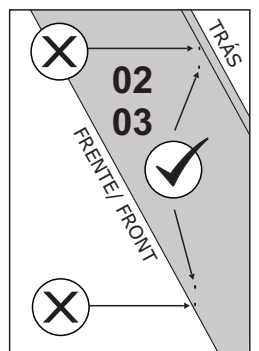

A=04
F=04

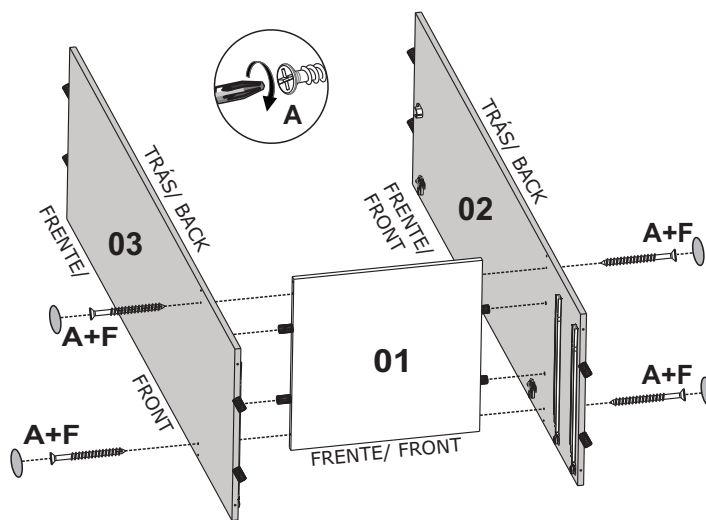
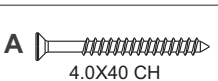

2

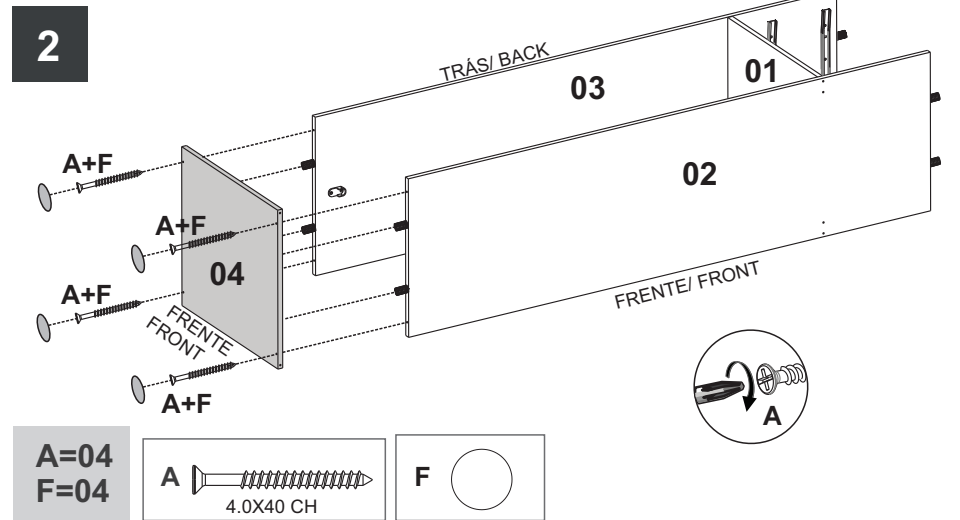

A=04
F=04

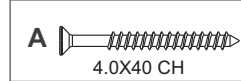

**MEDIDA UTILIZADA EM MM /
UNIT MEASURE USED IS MILLIMETERS (MM)**

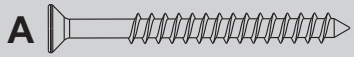

A PARAFUSO / SCREW / TORNILLO
4.0X40(MM) CH (22)

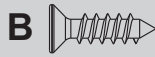

B PF / SCREW / TORNILLO
3,5X14(MM) CH (64)



C CAVILHA /
WOODEN DOWEL
TARUGO 8X30 (MM) (20)

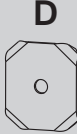

D GARRA /
JONT METAL PLATE
EMBRAGUES(04)

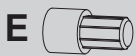

E SUPORTE PL/
SUPPORT
6X8MM (02)



F TAPA FURO ADESIVO/
HOLE STICKER/PEGATINA
DE AGUJERO 18 (MM) (08)



G SUPORTE PL/
PLASTIC SUPPORT
OBILONGO (02)



H1
H2 CORREDIÇA / METÁLLIC SLIDE
CORREDERA 400 (MM) (02 PAIR)

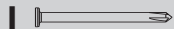

I PREGO / NAIL /
CLAVO 8X8 (MM) (50)

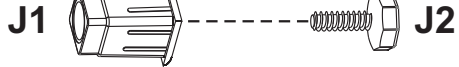

J1 BUCHA PL / BUSHING/
CASQUILLO 20X20
ROSCA 1/4 PP10 (04) **J2** PÉ PL. NOM. 12
NIVELADOR/ FOOT/
PIE 1/4 X 3/4 MM (04)

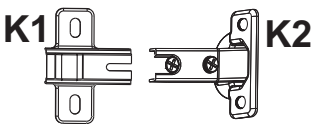

K1 DOBRAD. CANECO 35 MM/
HINGE/ BISAGRA (03) **K2**



L1 CANTONEIRA PL C TAMPA
PLASTIC CONER WHIT LID/
ESQUINA PL.20X20X42 MM (04) **L2**

| ITEM | | DESCRIÇÃO DA PEÇAS / DESCRIPTION OF PARTS / UNIT MEASURE USED IS MILLIMETERS (MM) | | | | CORES/ COLORS/ COLORES | | |
|---|--------|---|-------------------------|-----------|-----------------------|------------------------|-------------------|--------|
| COD. CODE | Nº | NOME/NAME/NOMBRE | MEDIDAS / MEASURES (MM) | TIPO TYPE | QUANT AMOUNT CANTIDAD | OFF WHITE | PRETO BLACK NEGRO | PINUS |
| 17324 | 1 | PRATELEIRA INTERNA/ SHELF/ ESTANTE INTERNA | 472X466X15 | MDP | 1 | 01/06 | 01/07 | 01/11 |
| 17326 | 2 | LATERAL ESQUERDA/ LEFT SIDE/ LADO IZQUIERDO | 1645X467X15 | MDP | 1 | 02/06 | 02/07 | 02/11 |
| 17327 | 3 | LATERAL DIREITA/ RIGHT SIDE/ LADO DERECHO | 1645X467X15 | MDP | 1 | 03/06 | 03/07 | 03/11 |
| 17328 | 4 | TAMPO/ TOP | 502X468X15 | MDF | 1 | 04/06 | 04/07 | 04/11 |
| 17331 | 5 | BASE | 502X468X15 | MDP | 1 | 05/06 | 05/07 | 05/11 |
| 17329 | 6 | FUNDO TRÁS/ BACK/ TRASEIRO | 492X436X3 | MDF | 3 | 06/06 | 06/07 | 06/11 |
| 17330 | 7 | FUNDO TRÁS/ BACK/ TRASEIRO | 492X347X3 | MDF | 1 | 07/06 | 07/07 | 07/11 |
| 17325 | 8 | PRATELEIRA INFERIOR/ BOTTOM SHELF/ ESTANTE INFERIOR | 502X468X15 | MDP | 1 | 08/06 | 08/07 | 08/11 |
| 17332 | 9 | REFORÇO TRAS/ BACK REINFORCEMENT/ REFUERZO TRASEIRO | 502X100X15 | MDP | 1 | 09/06 | 09/07 | 09/11 |
| 17333 | 10 | PORTA/ DOOR/ PUERTA | 1294X468X15 | MDF | 1 | 10/06 | 10/07 | 10/11 |
| 17334 | 11 | FRENTE GAVETA/ DRAWER FRONT / FRENTE DE CÁJON | 468X160X15 | MDF | 2 | 11/06 | 11/07 | 11/11 |
| 17335 | 12 | LATERAL GAVETA ESQUERDA/ LEFT DRAWER SIDE/ LADO CÁJON IZQUIERDO | 400X142X15 | MDP | 2 | 12/06 | 12/07 | 12/11 |
| 17336 | 13 | CONTRA FRENTE/ AGAINST DRAWER FRONT/ CONTRA FRENTE DEL CÁJON | 417X123X15 | MDP | 2 | 13/06 | 13/07 | 13/11 |
| 17337 | 14 | FUNDO GAVETA/ DRAWER BACKGROUND/ FONDO CÁJON | 432X408X3 | MDF | 2 | 14/06 | 14/07 | 14/11 |
| 17684 | 15 | LATERAL GAVETA DIREITA/ RIGHT DRAWER SIDE/ LADO CÁJON DERECHO | 400X142X15 | MDP | 2 | 15/06 | 15/07 | 15/11 |
| 438 | A | PF. / Screw / Tornillo 4,0x40(MM) CH | | | 22 | | | |
| 986 | B | PF. / Screw/ Tornillo 3,5x14(MM) CRR | | | 64 | | | |
| 137 | C | Cavilha / Wooden Dowel / Tarugo 8x30(MM) | | | 20 | | | |
| 911 | D | Garra/ Jont Metal Plate/ Embragues | | | 04 | | | |
| 12735 | | | | | | | | |
| 339 | E | Suporte Plástico STOP 6x8 (MM)/ Plástic Support | | | 02 | BRANCO | | CAFÉ |
| 13362 | | | | | | | PRETO | |
| 13877 | | | | | | GELO | | |
| 13363 | F | Tapa F. Ades./Holer Sticker/Pegatina de Agujero 18 mm | | | 08 | | PRETO | |
| 13897 | | | | | | | | NAT. W |
| 341 | G | Suporte PL Obilongo/Obolongo PL Support | | | 02 | CINZA | CINZA | CINZA |
| 140 | H | Corrediza./Metallic Slid/ Corredera 400 (MM) (02 Pair) | | | 02 (PAR) | | | |
| 248 | I | Prego / Nail / Clavo 8x8 (MM) | | | 50 | | | |
| 17450 | J1 | Bucha PL/ Bushing/ Casquillo 20X20 ROSCA 1/4 PP10 | | | 04 | PRETO | PRETO | PRETO |
| 17449 | J2 | PÉ PL. NOM. 12 NIVELADOR/ FOOT/ PIE 1/4 X 3/4MM | | | 04 | PRETO | PRETO | PRETO |
| 17206 | K1 | Dobradiça Metálica / Metal Hinge/ Bisagra Metálica 35 (MM) | | | 03 | | | |
| 17210 | K2 | Calço Metálico AL6/ Metal Hinge/ Bisagra Metálica | | | 03 | | | |
| 10006 | L1/ L2 | Cantoneira PL/Plast. corner with lid / Esquina PL. 20X20X42(MM) | | | 04 | | | BRANCO |
| 15175 | | | | | | CINZA | CINZA | |
| Dispositivo Anti Tombamento PL/ Anti Tipping Kit/ Kit Para no cair | | | | | | | | |
| 434 | M | Parafuso/ Screw/ Tornillo 4,0x25 CH | | | 04 | | | |
| 437 | N | Parafuso/ Screw/ Tornillo 4,0x35 CH | | | 04 | | | |
| 16537 | O | Bucha PL/ Bushing/ Casquillo 6x30 MM Sx6 | | | 04 | | | |
| 16438 | P1 | Abraçadeira Nylon/ Nylon Clamp/ Abraçadeira Nylon300 (MM) | | | 02 | | | |
| | P2 | Support Pl./ Plástic Suport/ Suporte Plástico 47X21X9 (MM) | | | 02 | | | |
| 17362 | Q | COLUNA METALÃO/METAL COLUMN/COLUMNA METÁLICA-1990X468X20 MM | | | 02 | OURO | OURO | PRETO |
| 439 | | | | | | OURO | OURO | |
| 17639 | R | PF. / Screw / Tornillo 4,0x40(MM) FL | | | 20 | | | PRETO |
| 11138 | S | Tubo AL obilongo/ Tube 463X14 (MM) | | | 01 | | | |
| 17655 | | | | | | | PRETO | |
| 17454 | T | Perfil H Pl./ Accessory To Join/ Accessorio P. Unirse 470X20X4 (MM) | | | 02 | BRANCO | | CAFÉ |
| | | Certif. de Garant./ Warranty Certif. | | | 01 | | | |

Kit Anti Tombamento/ Anti Tipping Kit/ Kit para no Caer

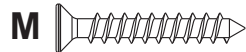

M PF / SCREW / TORNILLO
4,0x25 (MM) CRR (04)



O BUCHA PL / BUSHING/
CASQUILLO 6X30 MM Sx6
(04)

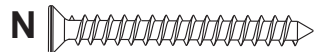

N PF / SCREW / TORNILLO
4.0X35 (MM) CH (04)



P1 ABRACADEIRA NYLON/ NYLON CLAMP/
ABRAZADERA NYLON 300MM (02)



P2 SUPORTE PL/
PL SUPPORT
47X21X9 MM (04)

Q COLUNA METAL/ METAL COLUMN/
COLUMNA METÁLICA-1990X468X20 MM (02)

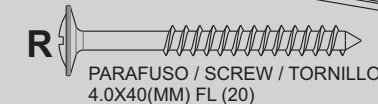

R PARAFUSO / SCREW / TORNILLO
4.0X40(MM) FL (20)



S TUBO AL. OBILONGO/
TUBE/ 463 MM (01)

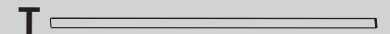

T PERFIL H PL/ ACCESSORY TO JOIN
ACCESSORIO PARA UNIRSE 470 MM (02)

3

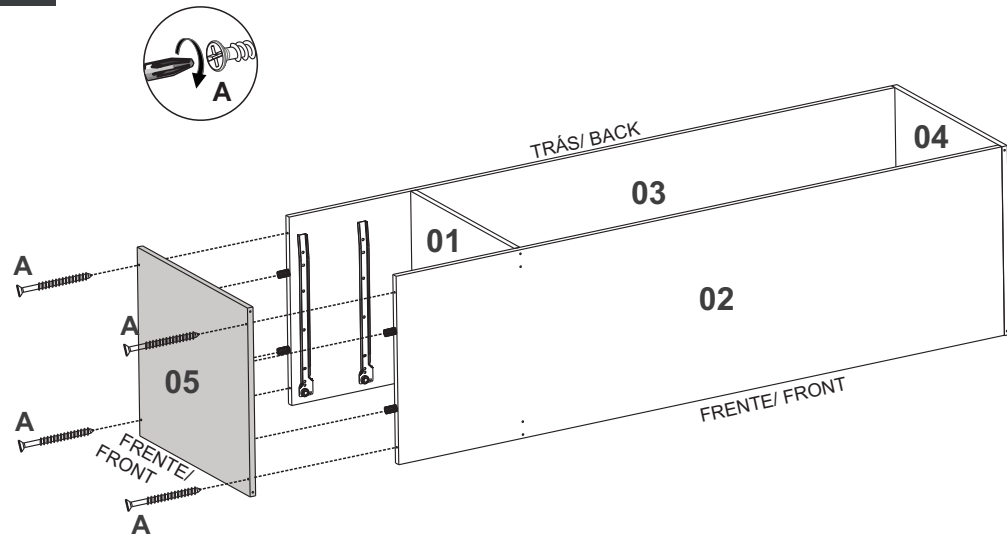

A=04

4.0X40 CH

4

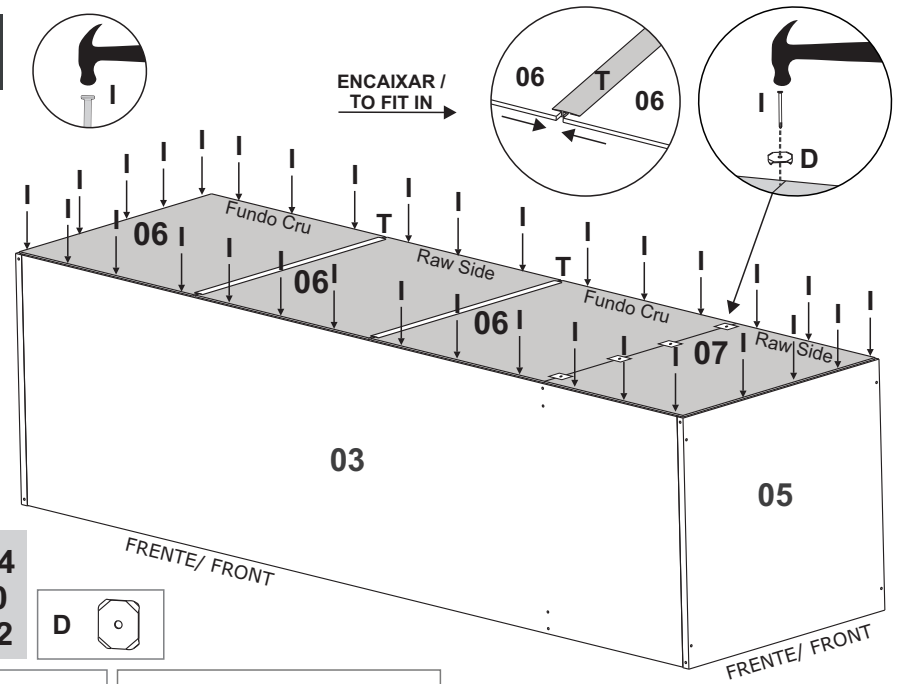

D=04
I=50
T=02

5

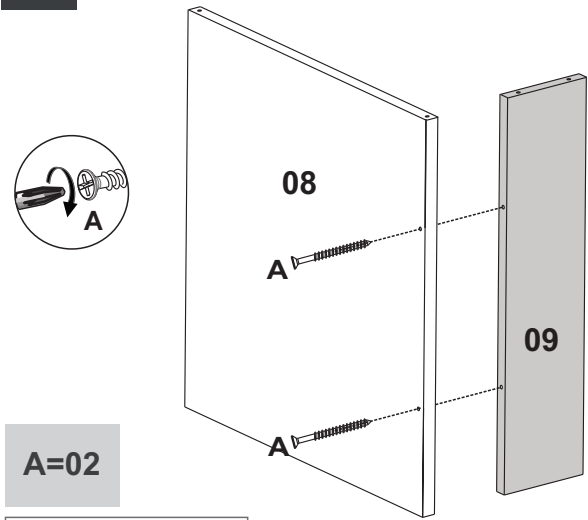

A=02

4.0X40 CH

6

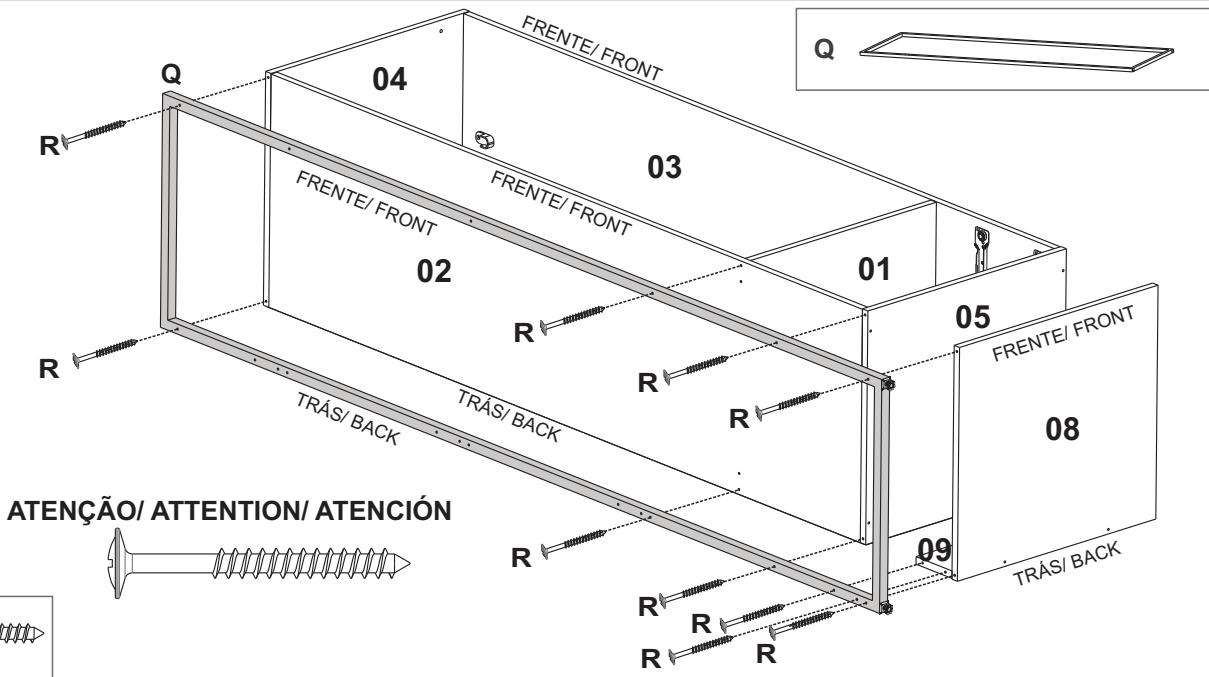

R=10
Q=01

4.0X40 FL

7

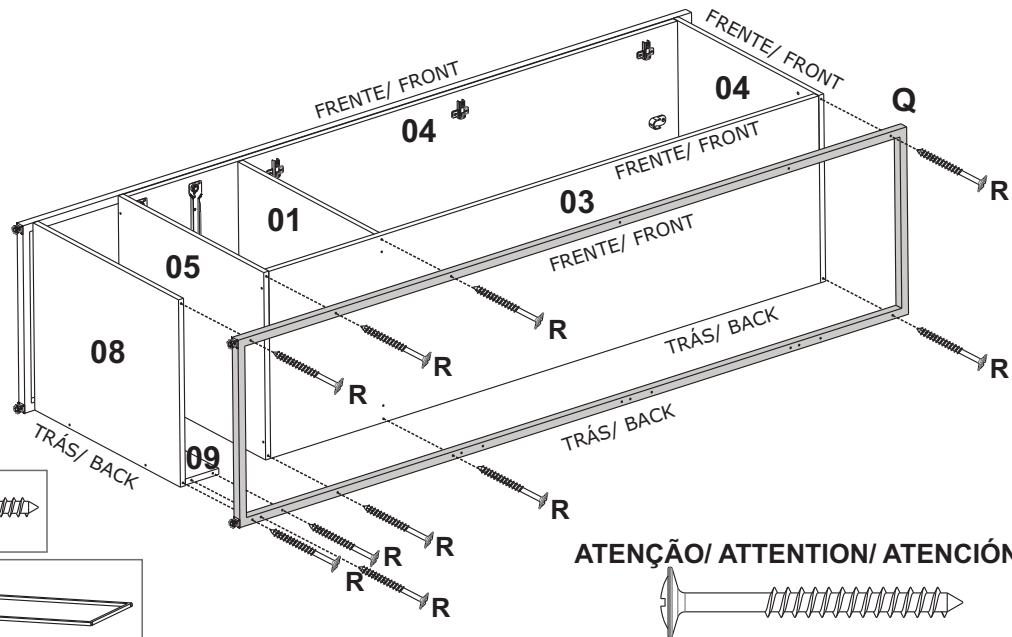

R=10
Q=01

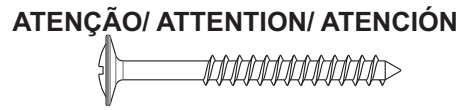
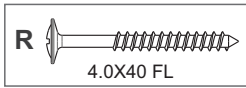

8

S=01

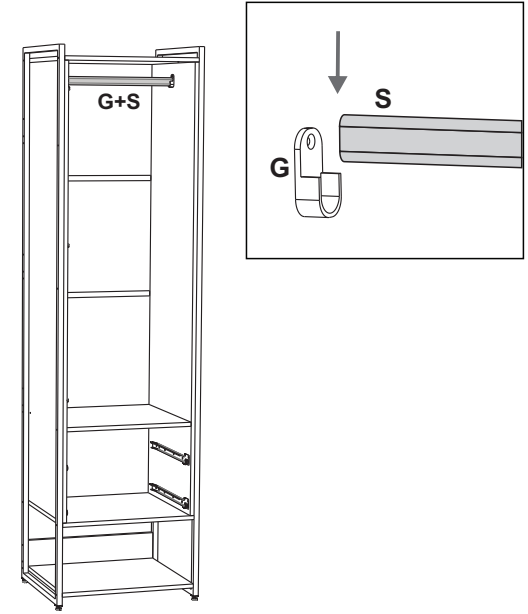
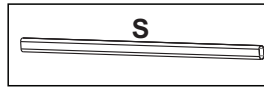

9

REGULAR O PÉ/
FOOT ADJUSTMENT/
AJUSTE PIE

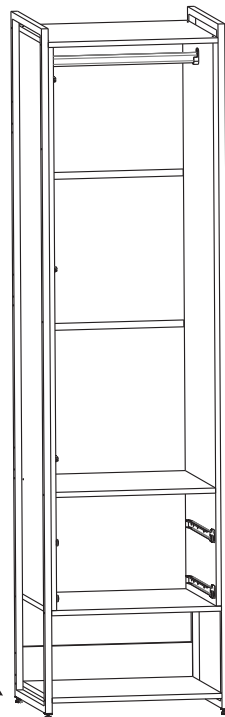
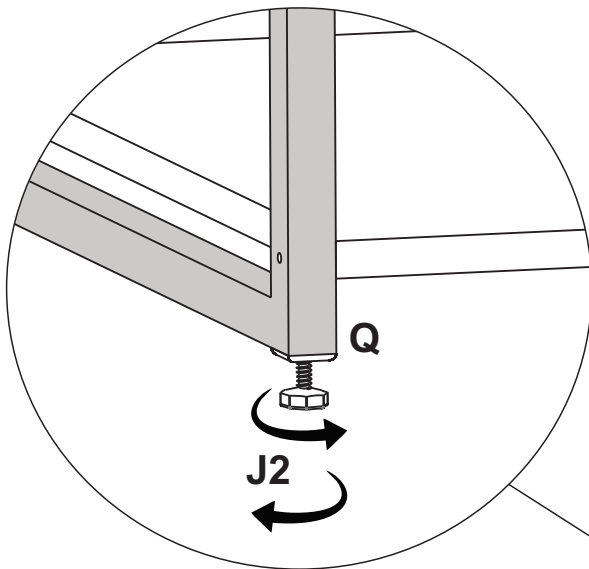

10

REGULAR E APERTAR
ADJUST AND TIGHTEN
AJUSTE Y APRIETE

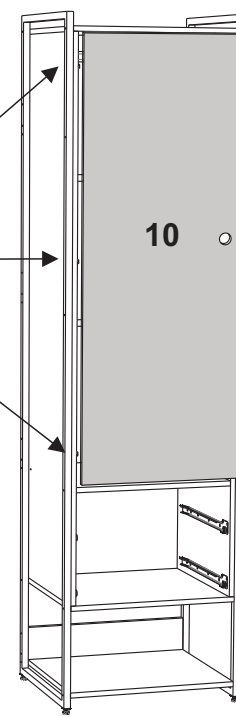
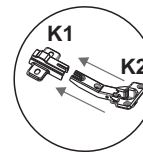

FIXAR DOBRADIÇAS/
FIXING THE HINGE/ BISAGRA

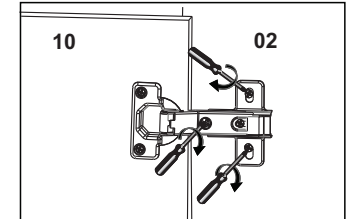

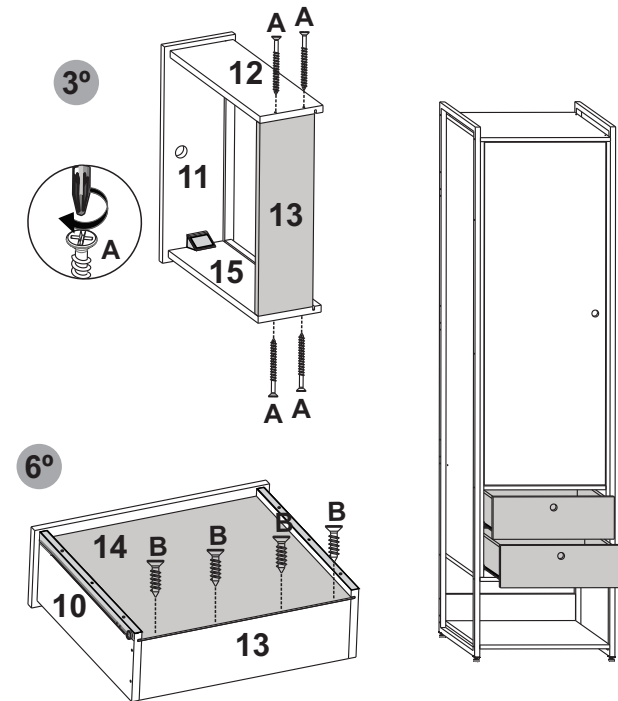
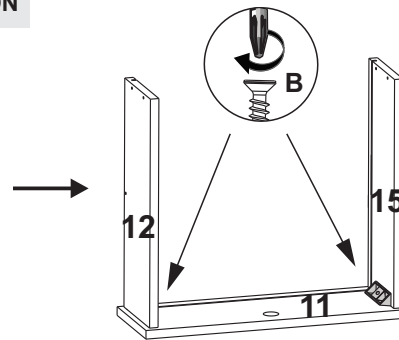
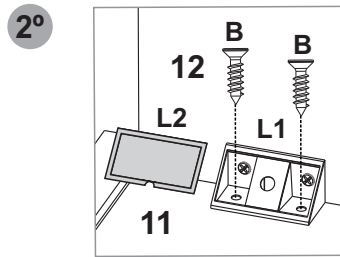
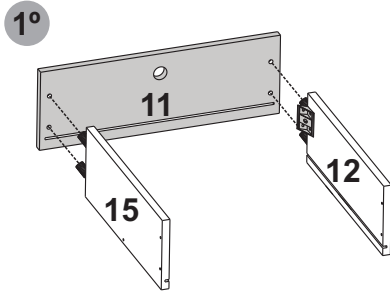

A=12
B=28
H2=04
L2=04

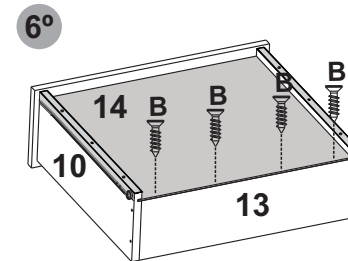
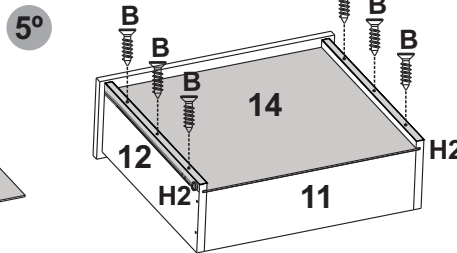
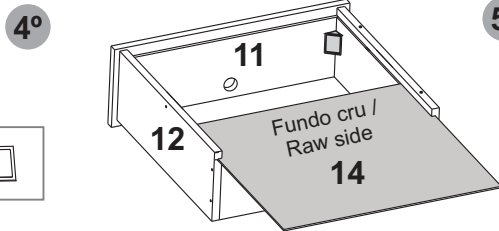
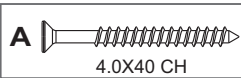

CUIDADO/
CAUTION/
PRECAUCIÓN

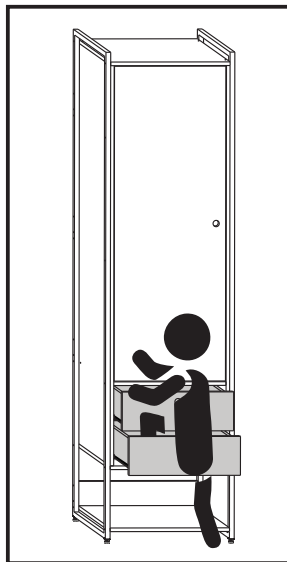

SE TIVER CRIANÇA, ACONSELHAMOS COLOCAR O KIT TOMBAMENTO, EVITANDO ACIDENTES.
IF YOU HAVE A CHILD, WE RECOMMEND PUTTING THE TIPPING KIT, AVOIDING ACCIDENTS.
SI TIENE UN HIJO, ACONSEJAMOS PONER EL KIT TIPPING, EVITANDO ACCIDENTES.

Kit Anti Tombamento/ Anti Tipping Kit/ Kit para no Caer

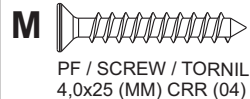

BUCHA PL / BUSHING/
CASQUILLO 6X30 MM Sx6
(04)

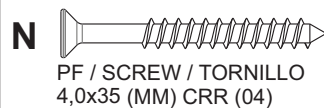

ABRACADEIRA NYLON/ NYLON CLAMP/
ABRAZADERA NYLON 300MM (02)



SUPORTE PL/
PL SUPPORT
47X21X9 MM (04)

ATENÇÃO/
ATTENTION / ATENCION

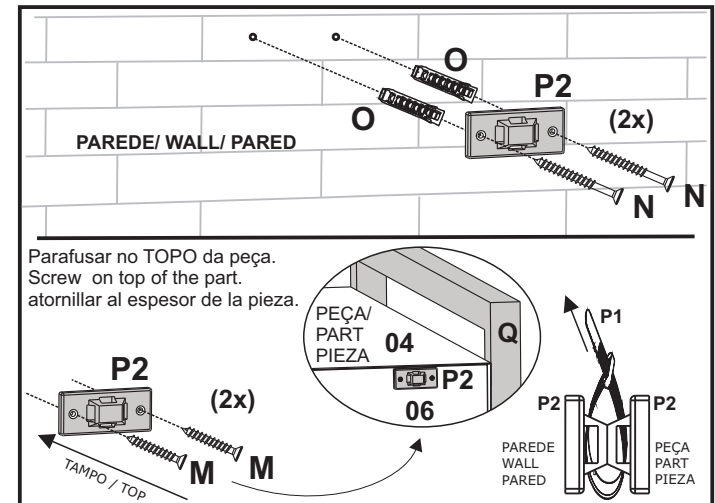

NOTA / NOTE

Não nos responsabilizamos por acidentes, se a instalação do móvel não estiver com os procedimentos deste Manual e não for realizado por pessoa habilitada.
We are not responsible for accidents if the installation of the furniture is not in accordance with the procedures in this Manual and is not carried out by a qualified person.
No nos hacemos responsables de accidentes si la instalación de los muebles no se realiza de acuerdo con los procedimientos de este Manual y no es realizada por una persona calificada.

DIMENSÕES DO PRODUTO / PRODUCT DIMENSIONS / DIMENSIONS PRODUCT - WxDxH / LxDxA - 542 X 470 X 2000 MM

ATENÇÃO/ ATENCION/ ATTENTION

ESTE PRODUTO NÃO PODE SER ARRASTADO.
THIS PRODUCT MUSTNOT BE DRAGGED.
ESTE PRODUCTO NO SE PUEDE ARRASTRAR.

PEÇAS NUMERADAS/ NUMBERED PARTS/
PIEZAS NUMERADAS
EX: 1915X-X 10 (peça/ piece/ pieza number)

Ferramentas necessárias / Necessary tools / Herramientas Necesarias
(não fornecidas) (not provided) (No proporcionadas)



MONTAR O PRODUTO SOBRE A EMBALAGEM,
EVITANDO DANOS NA PINTURA.
ACONSELHAMOS QUE A MONTAGEM DO PRODUTO
SEJA POR UM PROFISSIONAL.

SETUP THE PRODUCT ON TOP OF THE PACKAGING, AVOIDING
DAMAGE TO THE PAINT.
WE RECOMMEND THAT THE INSTALLATION IS DONE BY
A PROFESSIONAL.

MONTAR EL PRODUCTO EN EL PAQUETE,
EVITAR LESIONES EN PINTURA.
AVISAMOS QUE EL MONTAJE DEL PRODUCTO
SEA UN PROFESIONAL.



ATENÇÃO / ATTENTION / ATENCION

Nunca utilizar óleos, lustra móveis, produtos abrasivos, saponáceos, esponja de aço e outros.

Never use oils, furniture polish, abrasive products, soaps, steel sponge and others.

Nunca use aceites, pulimentos, abrasivos, jabones, esponja de acero y otros.

CUIDADOS ESPECIAIS/ SPECIAL CARE/ CUIDADOS ESPECIALES

- Evitar expor o móvel ao sol, e em lugares úmidos.
- Limpar com flanela seca ou com pano levemente umedecido em água.
- Avoid exposing the furniture to the sun, and in damp places.
- Clean with dry flannel or lightly cloth moistened with water.
- Evite exponer los muebles al sol y en lugares húmedos.
- Limpiar con flanela seca o un paño ligero, humedecido con agua.

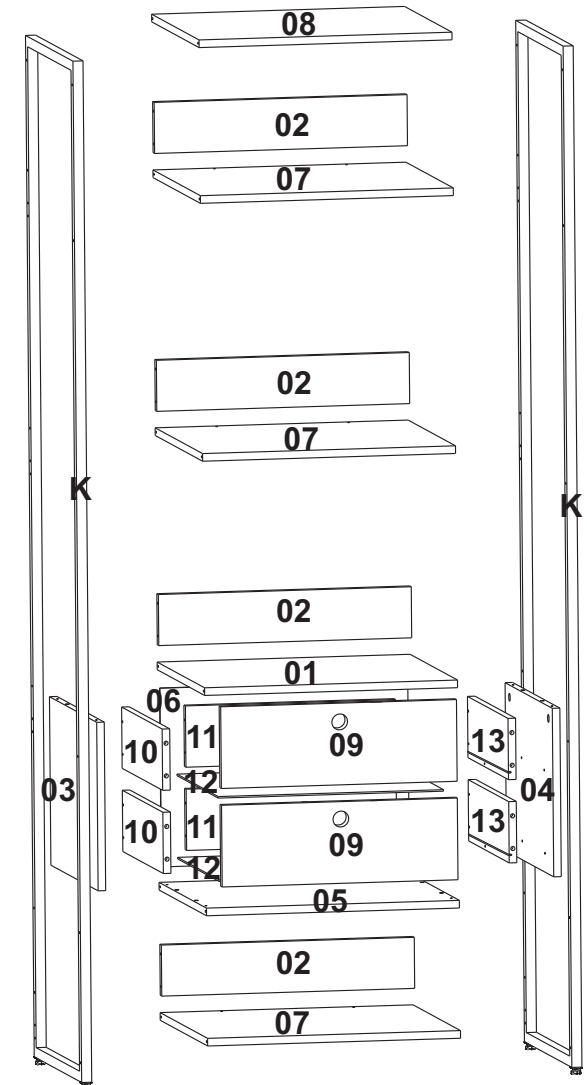
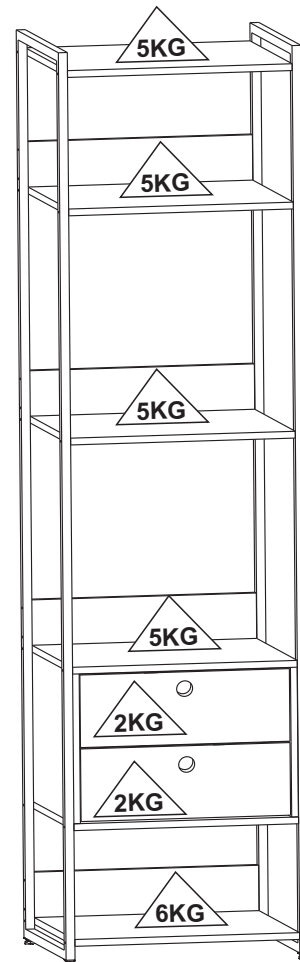

**MEDIDA UTILIZADA EM MM /
UNIT MEASURE USED IS MILLIMETERS (MM)**

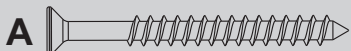

A PARAFUSO / SCREW / TORNILLO
4.0X40(MM) CH (20)

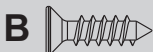

B PF / SCREW /
TORNILLO
3,5X14(MM) CH (48)



C CAVILHA /
WOODEN DOWEL
TARUGO 8X30 (MM) (16)



D PINO MINIFIX /
MINI FIX SCREW 32 (MM) (04)



E TAMBOR MINIFIX /
MINI FIX ROUND NUT
15 (MM) (04)

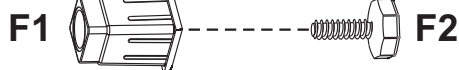

F1 BUCHA PL / BUSHING/
CASQUILLO 20X20
ROSCA 1/4 PP10 (04)

F2 PÉ PL. NOM. 12
NIVELADOR/ FOOT/
PIE 1/4 X 3/4 MM (04)



G1 (04) **G2** (04)

CANTONEIRA PL C TAMPA
PLASTIC CONER WHIT LID/
ESQUINA PL.20X20X42 MM (04)



H1 **H2**

CORREDIÇA / METÁLLIC SLIDE
CORREDERA 400 (MM) (02 PAIR)

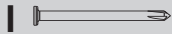

I PREGO / NAIL / CLAVO
8X8 (MM) (20)

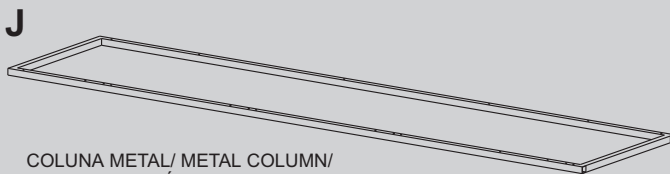

J

COLUNA METAL/ METAL COLUMN/
COLUMN METÁLLICA-1990X468X20 MM (02)

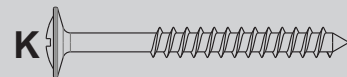

K PARAFUSO / SCREW / TORNILLO
4.0X40(MM) FL (40)

| ITEM | | DESCRIÇÃO DA PEÇAS / DESCRIPTION OF PARTS / UNIT MEASURE USED IS MILLIMETERS (MM) | | | | | CORES/ COLORS/ COLORES | | |
|---|-------|---|-------------------------|-----------|-----------------------|-----------|------------------------|--------|--|
| COD. CODE | Nº | NOME/NAME/NOMBRE | MEDIDAS / MEASURES (MM) | TIPO TYPE | QUANT AMOUNT CANTIDAD | OFF WHITE | PRETO BLACK NEGRO | PINUS | |
| 17216 | 1 | TAMPO/ TOP | 502X468X15 | MDP | 1 | 01/06 | 01/07 | 01/11 | |
| 17217 | 2 | REFORÇO TRAS/ BACK REINFORCEMENT | 502X100X15 | MDP | 4 | 02/06 | 02/07 | 02/11 | |
| 17218 | 3 | LATERAL ESQUERDA/ LEFT SIDE/ LADO IZQUIERDO | 330X467X15 | MDP | 1 | 03/06 | 03/07 | 03/11 | |
| 17219 | 4 | LATERAL DIREITA/ RIGHT SIDE/ LADO DERECHO | 330X467X15 | MDP | 1 | 04/06 | 04/07 | 04/11 | |
| 17220 | 5 | BASE | 502X468X15 | MDP | 1 | 05/06 | 05/07 | 05/11 | |
| 17221 | 6 | FUNDO TRÁS/ BACK/ FONDO TRASERO | 492X350X03 | MDF | 1 | 06/06 | 06/07 | 06/11 | |
| 17222 | 7 | PRATELEIRA CENT/INF/ CENTRAL BOTTOON SHELF/ ESTANTE | 502X468X15 | MDP | 3 | 07/06 | 07/07 | 07/11 | |
| 17223 | 8 | PRATELEIRA SUPERIOR/ HIGHER SHELF/ ESTANTE SUPERIOR | 502X468X15 | MDP | 1 | 08/06 | 08/07 | 08/11 | |
| 17224 | 9 | FRENTE GAVETA/ DRAWER FRONT/ FRENTE DE CÁJON | 468X160X15 | MDF | 2 | 09/06 | 09/07 | 09/11 | |
| 17225 | 10 | LATERAL GAV ESQUERDA/ LEFT DRAWER SIDE/ LADO IZQ. CÁJON | 400X142X15 | MDP | 2 | 10/06 | 10/07 | 10/11 | |
| 17226 | 11 | CONTRA FRENTE/ AGAINST DRAWER FRONT/ CONTRA FRENTE DEL CÁJON | 417X123X15 | MDP | 2 | 11/06 | 11/07 | 11/11 | |
| 17227 | 12 | FUNDO GAVETA/ DRAWER BACKGROUND/ FONDO CÁJON | 432X408X3 | MDF | 2 | 12/06 | 12/07 | 12/11 | |
| 17680 | 13 | LATERAL GAVETA DIREITA/ RIGHT DRAWER SIDE/ LADO DERECHO CÁJON | 400X142X15 | MDP | 2 | 13/06 | 13/07 | 13/11 | |
| 438 | A | PF. / Screw / Tornillo 4,0x40 (MM) CH | | | 20 | | | | |
| 986 | B | PF./ Screw / Tornillo 3,5x14 (MM) CRR | | | 48 | | | | |
| 137 | C | Cavilha / Wooden Dowel / Tarugo 8x30 (MM) | | | 16 | | | | |
| 532 | D | Pino Minifix /Minifix Screw 32 (MM) | | | 04 | | | | |
| 508 | E | Tambor Minifix / Minifix Round Nut 15 (MM) | | | 04 | | | | |
| 17450 | F1 | Bucha PL/ Bushing/ Casquillo 20X20 ROSCA 1/4 PP10 | | | 04 | PRETO | PRETO | PRETO | |
| 17449 | F2 | PÉ PL. NOM. 12 NIVELADOR/ FOOT/ PIE 1/4 X 3/4MM | | | 04 | PRETO | PRETO | PRETO | |
| 10006 | G1/G2 | Cantoneira PL/Plast. corner with lid / Esquina PL. 20X20X42 (MM) | | | 04 | | | BRANCA | |
| 15175 | | | | | | | CINZA | CINZA | |
| 140 | H | Corred./Metallic Slid/ Corredera 400 (MM) (02 Pair) | | | 02 (PAR) | | | | |
| 248 | I | Prego / Nail / Clavo 8x8 (MM) | | | 20 | | | | |
| 17362 | J | COLUNA METALÃO/METAL COLUMN/COLUMN METÁLLICA-1990X468X20 MM | | | 02 | OURO | OURO | PRETO | |
| 439 | K | PF. / Screw / Tornillo 4,0x40 (MM) FL | | | 40 | OURO | OURO | | |
| 17639 | | | | | | | | PRETO | |
| Dispositivo Anti Tombamento PL/ Anti Tipping Kit/ Kit Para no cair | | | | | | | | | |
| 434 | M | Parafuso/ Screw/ Tornillo 4,0x25 CH | | | 04 | | | | |
| 437 | N | Parafuso/ Screw/ Tornillo 4,0x35 CH | | | 04 | | | | |
| 16537 | O | Bucha PL/ Bushing/ Casquillo 6x30 MM Sx6 | | | 04 | | | | |
| 16438 | P1 | Abraçadeira Nylon/ Nylon Clamp/ Abrazadeira Nylon300 (MM) | | | 02 | | | | |
| | P2 | Suport Pl./ Plástic Suport/ Suporte Plástico 47X21X9 (MM) | | | 02 | | | | |
| | | Certif. de Garant./ Warranty Certif. | | | 01 | | | | |

Kit Anti Tombamento/ Anti Tipping Kit/ Kit para no Caer



M PF / SCREW / TORNILLO
4,0x25 (MM) CRR (04)



O BUCHA PL / BUSHING/
CASQUILLO 6X30 MM SX6
(04)



N PF / SCREW / TORNILLO
4.0X35 (MM) CH (04)



P1 ABRACADEIRA NYLON/ NYLON CLAMP/
ABRAZADERA NYLON 300MM (02)



P2 SUPORTE PL/
PL SUPPORT
47X21X9 MM (04)

PREPARAÇÃO DE PEÇAS/ PARTS PREPARATION / PREPARACION DE PIEZAS

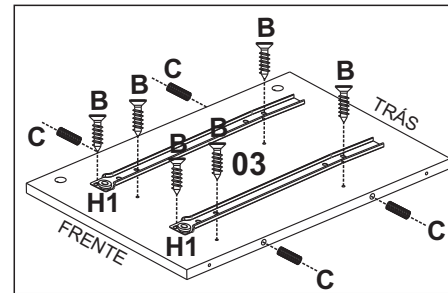
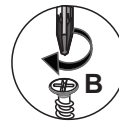
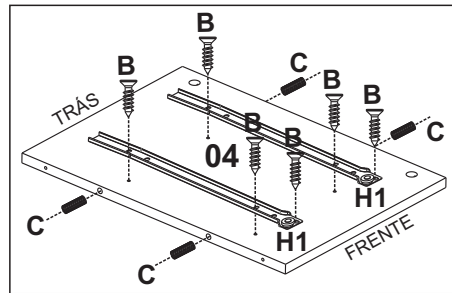
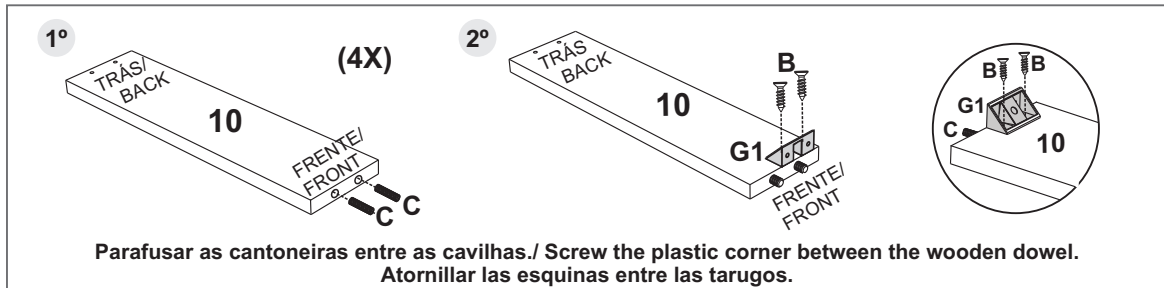
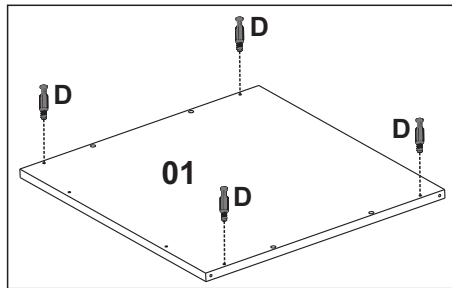
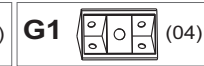
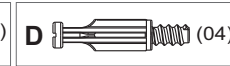
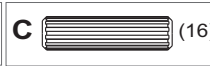

1

Obs: As peças pintadas nos passos são apenas ilustrativas.
The parts painted in the steps are illustrative only.
Las partes pintadas en los pasos son solo ilustrativas.

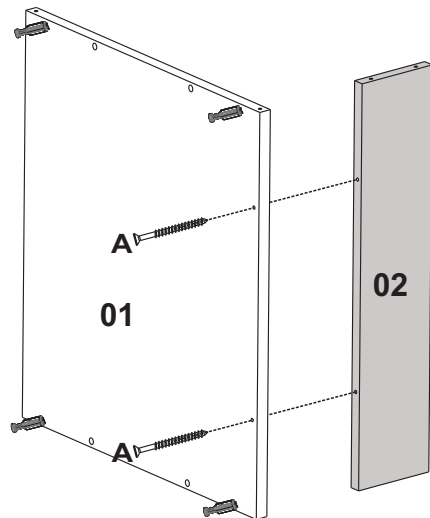
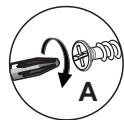

A=02

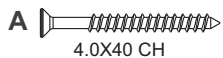

2

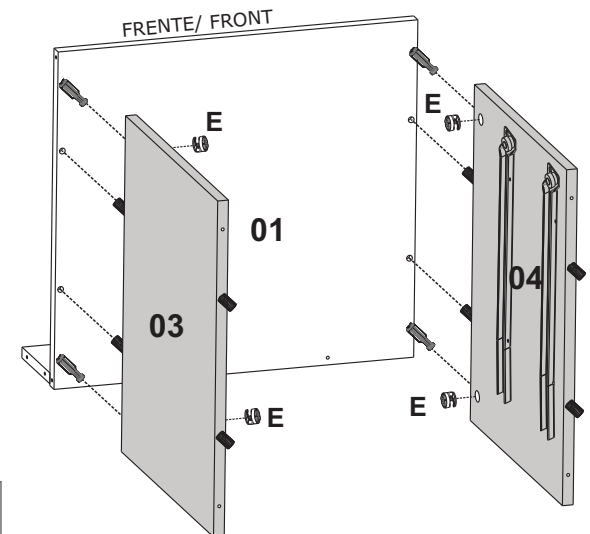

E=04



3

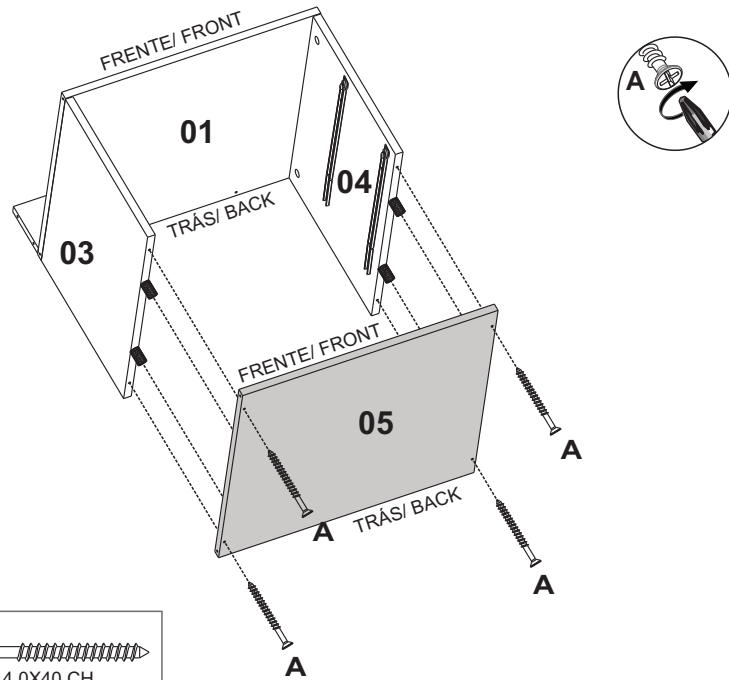

A=04

4.0X40 CH

4

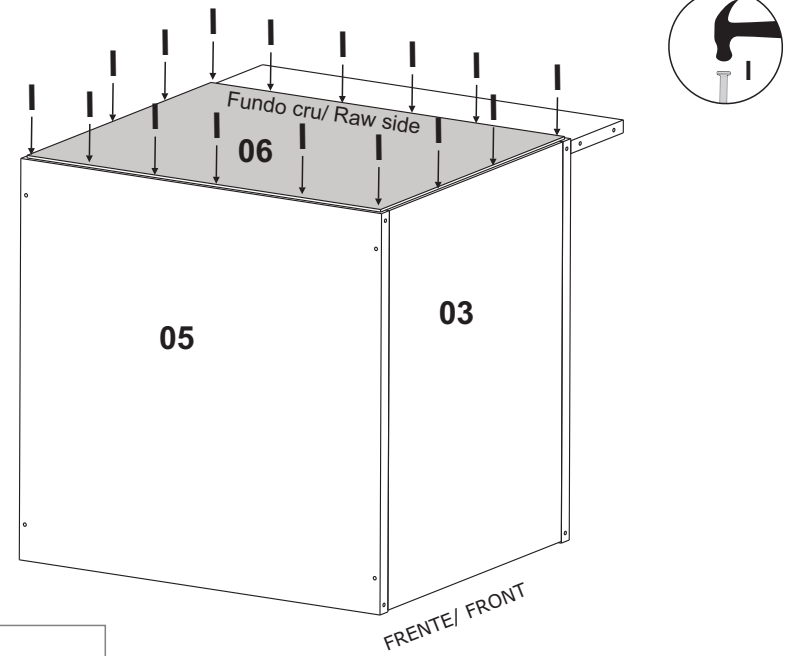

I=20

5

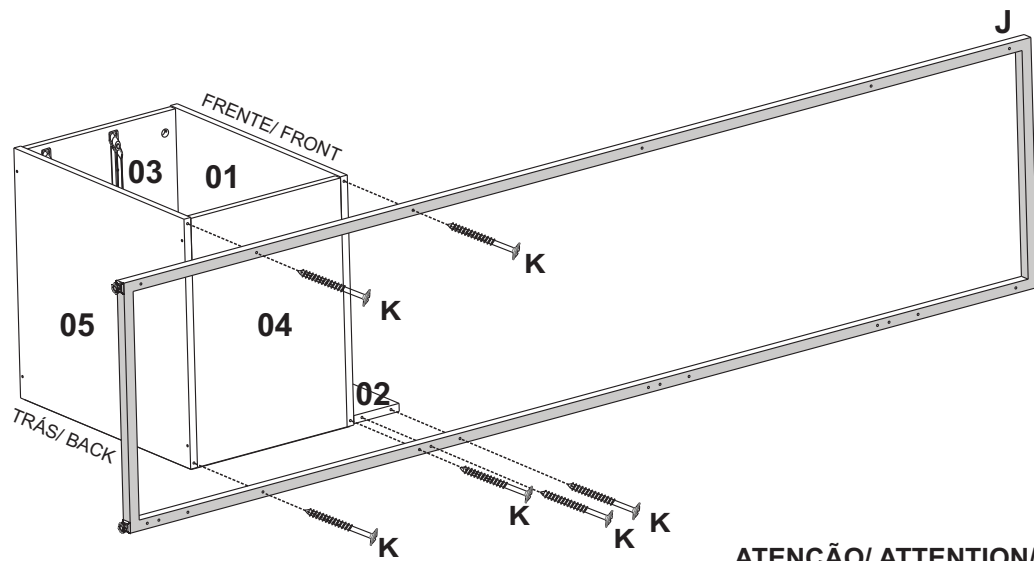

K=06
J=01

4.0X40 FL

ATENÇÃO/ ATTENTION/ ATENCIÓN

6

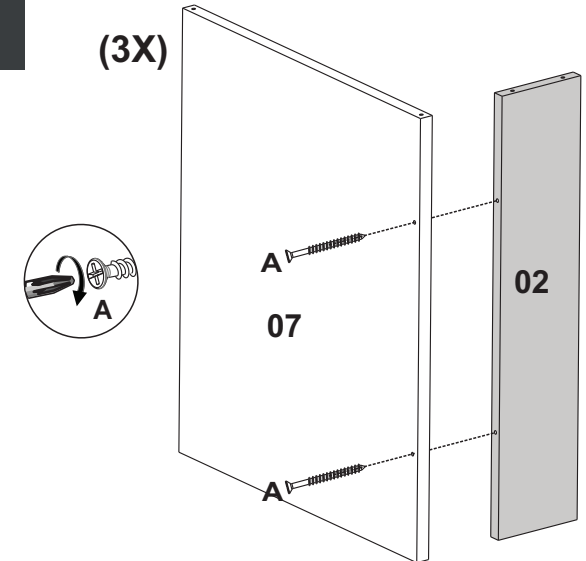

A=06

4.0X40 CH

7

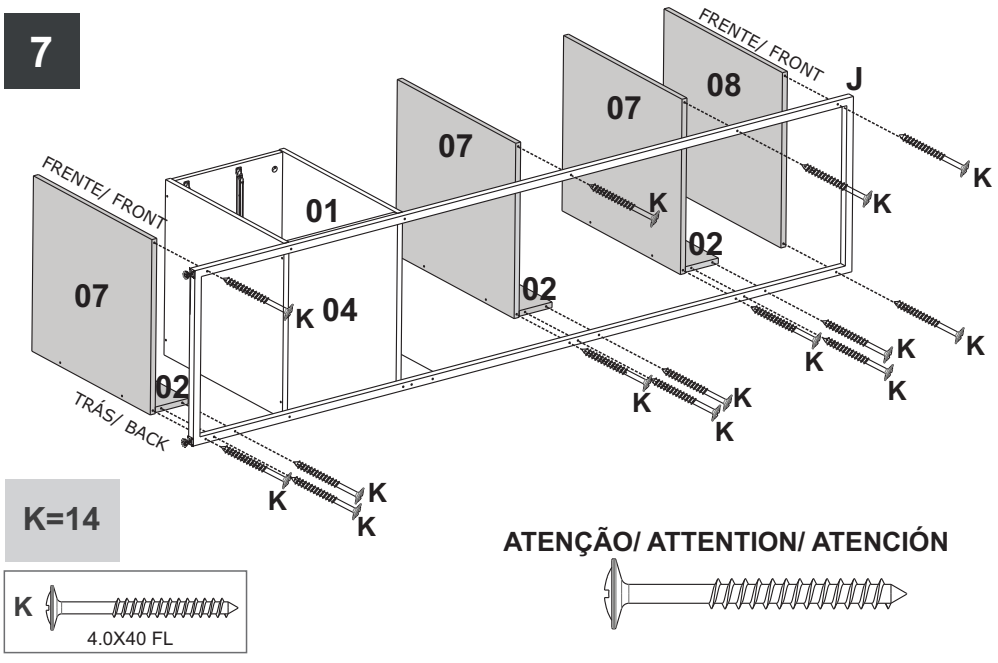

8

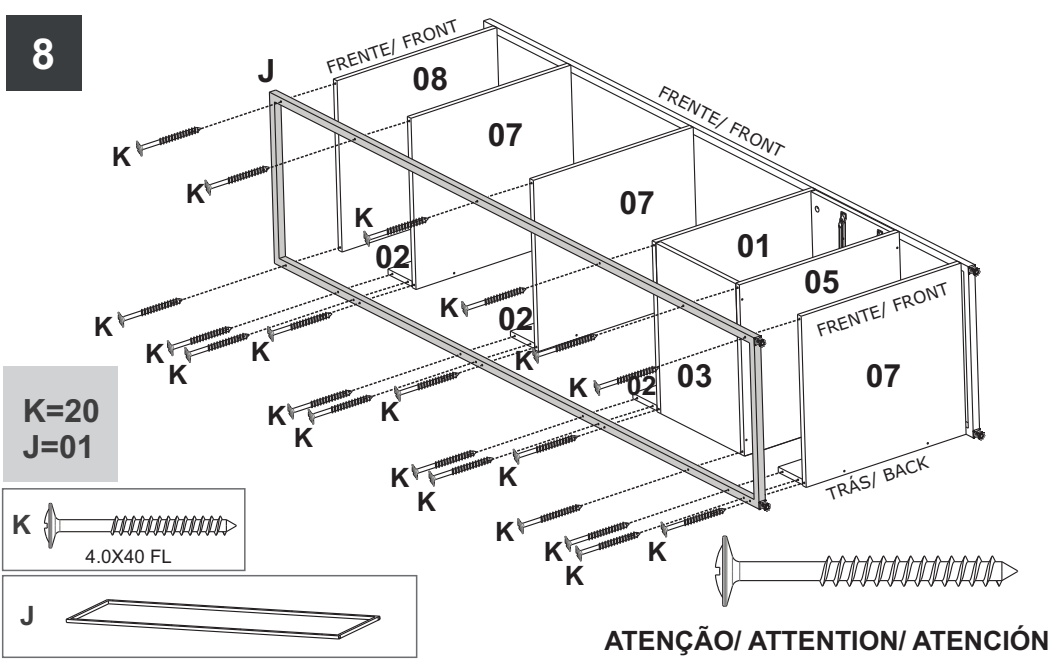

9

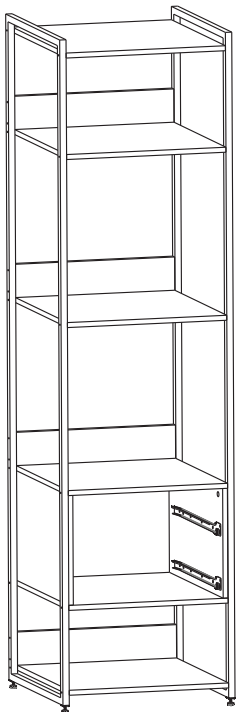

10

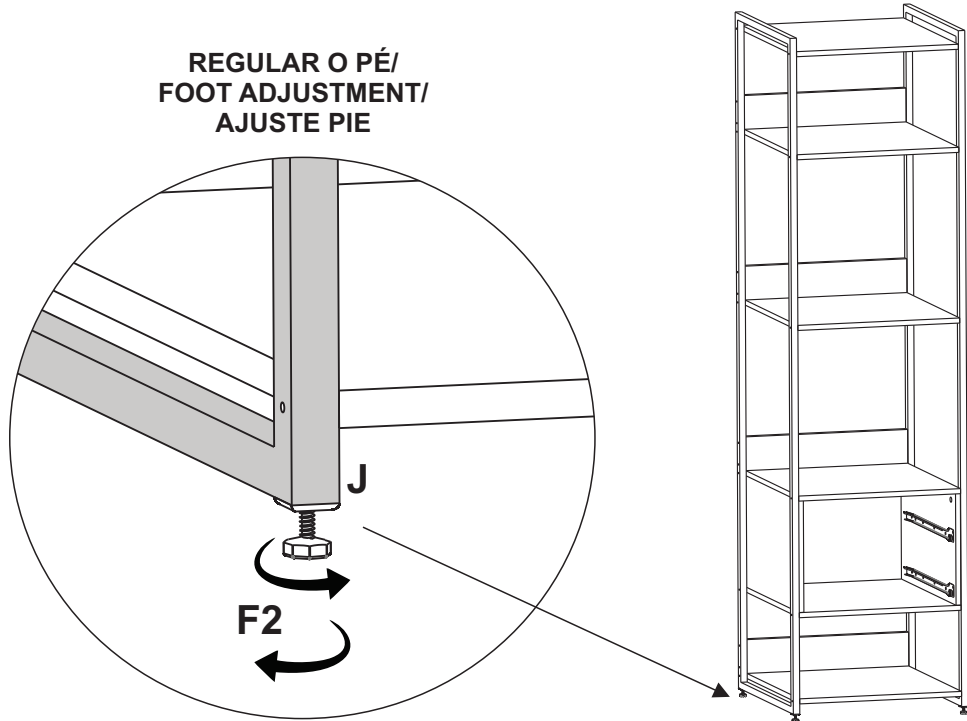

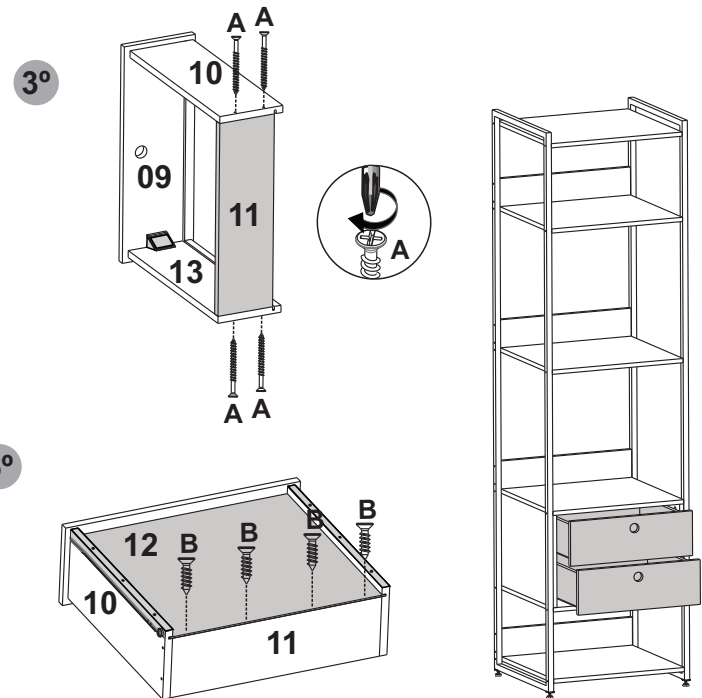
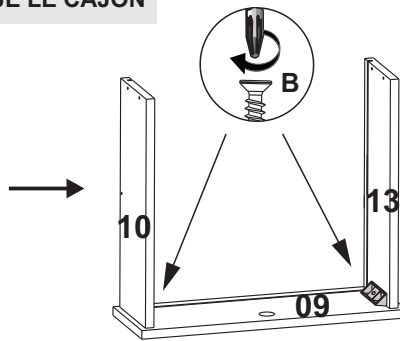
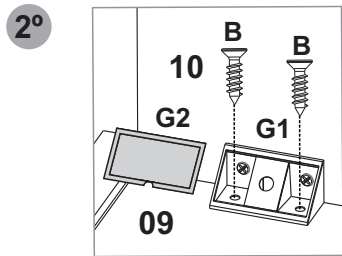
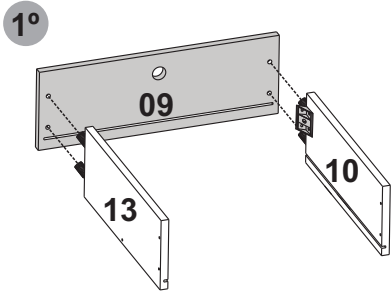

A=08
B=28
G2=04
H2=04

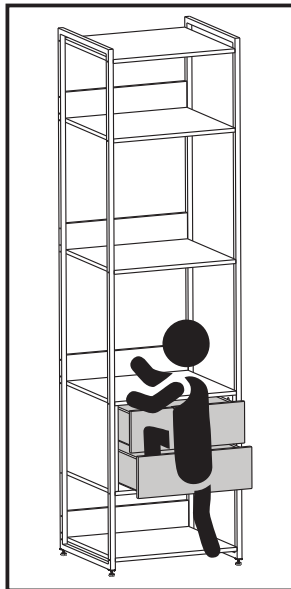
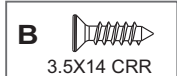
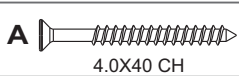
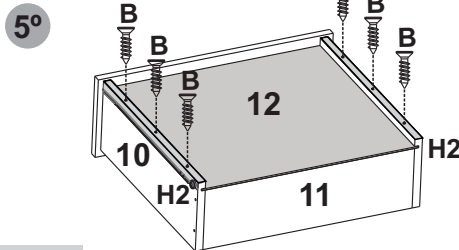
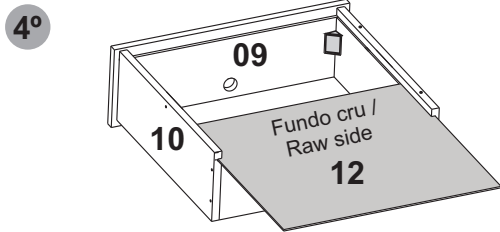

SE TIVER CRIANÇA, ACONSELHAMOS COLOCAR O KIT TOMBAMENTO, EVITANDO ACIDENTES.
IF YOU HAVE A CHILD, WE RECOMMEND PUTTING THE TIPPING KIT, AVOIDING ACCIDENTS.
SI TIENE UN HIJO, ACONSEJAMOS PONER EL KIT TIPPING, EVITANDO ACCIDENTES.

Kit Anti Tombamento/ Anti Tipping Kit/ Kit para no Caer

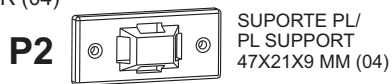
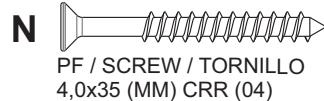
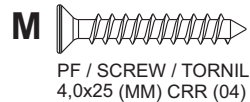

ATENÇÃO/ ATTENTION / ATENCION

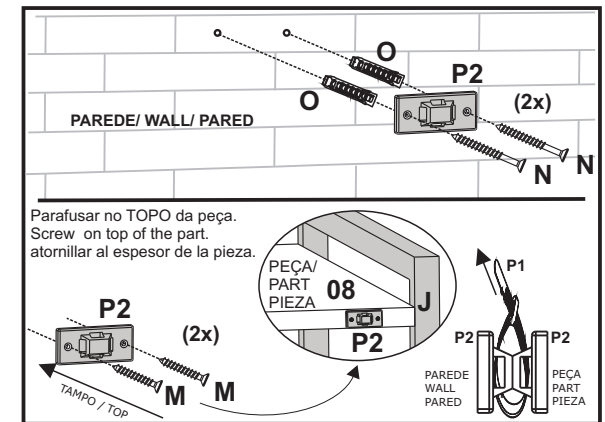

NOTA / NOTE

Não nos responsabilizamos por acidentes, se a instalação do móvel não estiver com os procedimentos deste Manual e não for realizado por pessoa habilitada. We are not responsible for accidents if the installation of the furniture is not in accordance with the procedures in this Manual and is not carried out by a qualified person. No nos hacemos responsables de accidentes si la instalación de los muebles no se realiza de acuerdo con los procedimientos de este Manual y no es realizada por una persona calificada.

DIMENSÕES DO PRODUTO / PRODUCT DIMENSIONS / DIMENSIONS PRODUCT - WxDxH / LxDxA - 890 X 470 X 2000MM

ATENÇÃO/ ATENCION/ ATTENTION

ESTE PRODUTO NÃO PODE SER ARRASTADO.
THIS PRODUCT MUSTNOT BE DRAGGED.
ESTE PRODUCTO NO SE PUEDE ARRASTRAR.

PEÇAS NUMERADAS/ NUMBERED PARTS/
PIEZAS NUMERADAS
EX: 1915X-X 10 (peça/ piece/ pieza number)

Ferramentas necessárias / Necessary tools / Herramientas Necesarias
(não fornecidas) (not provided) (No proporcionadas)

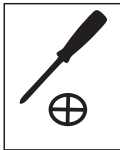

MONTAR O PRODUTO SOBRE A EMBALAGEM,
EVITANDO DANOS NA PINTURA.
ACONSELHAMOS QUE A MONTAGEM DO PRODUTO
SEJA POR UM PROFISSIONAL.

SETUP THE PRODUCT ON TOP OF THE PACKAGING, AVOIDING
DAMAGE TO THE PAINT.
WE RECOMMEND THAT THE INSTALLATION IS DONE BY
A PROFESSIONAL.

MONTAR EL PRODUCTO EN EL PAQUETE,
EVITAR LESIONES EN PINTURA.
AVISAMOS QUE EL MONTAJE DEL PRODUCTO
SEA UN PROFESIONAL.

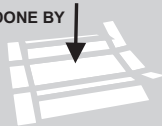

ATENÇÃO / ATTENTION / ATENCION

Nunca utilizar óleos, lustra móveis, produtos abrasivos, saponáceos, esponja de aço e outros.

Never use oils, furniture polish, abrasive products, soaps, steel sponge and others.

Nunca use aceites, pulimentos, abrasivos, jabones, esponja de acero y otros.

CUIDADOS ESPECIAIS/ SPECIAL CARE/ CUIDADOS ESPECIALES

- Evitar expor o móvel ao sol, e em lugares úmidos.
- Limpar com flanela seca ou com pano levemente umedecido em água.

- Avoid exposing the furniture to the sun, and in damp places.
- Clean with dry flannel or lightly cloth moistened with water.

- Evite exponer los muebles al sol y en lugares húmedos.
- Limpiar con flanela seca o un paño ligero, humedecido con agua.

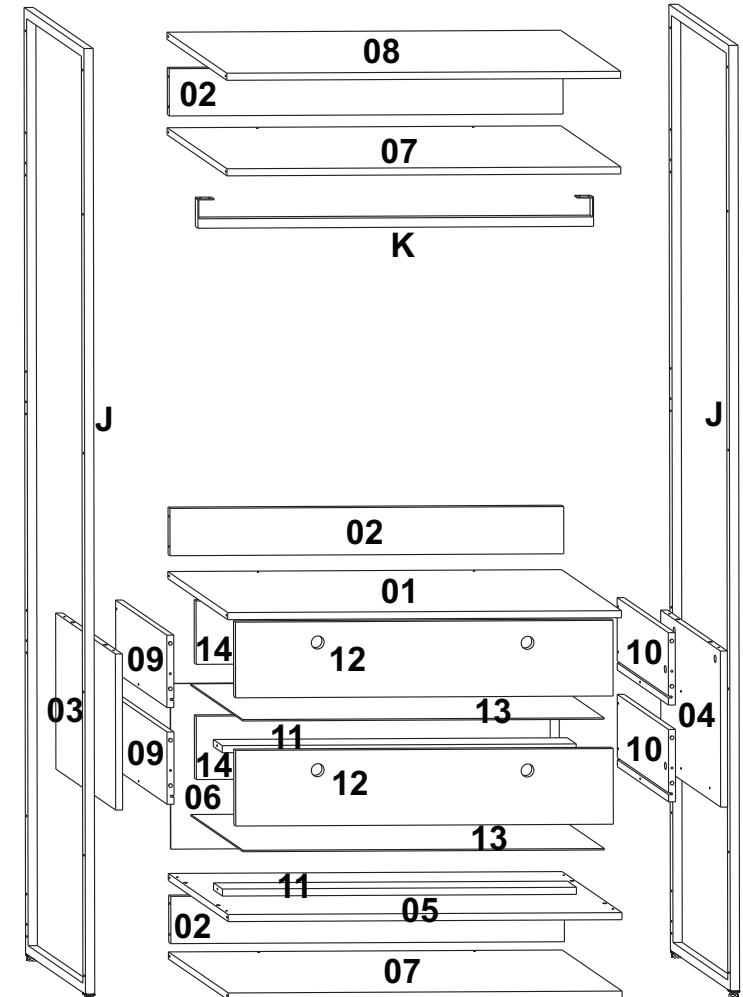
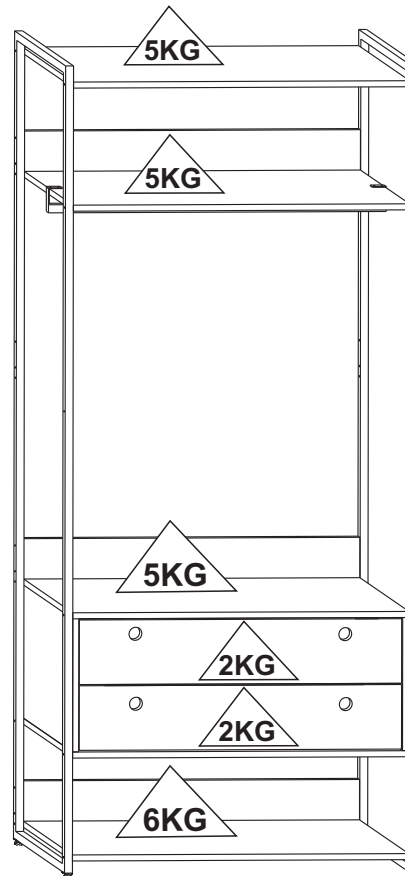

**MEDIDA UTILIZADA EM MM /
UNIT MEASURE USED IS MILLIMETERS (MM)**

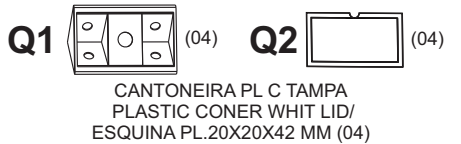
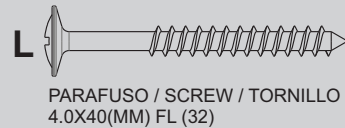
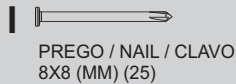
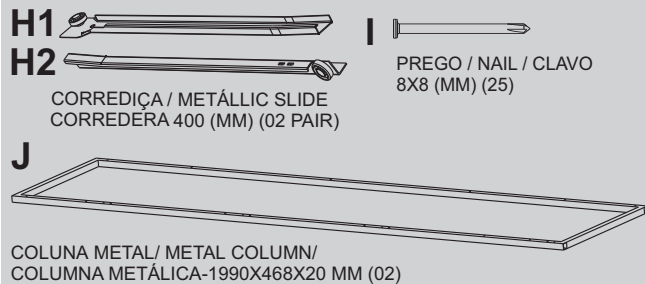
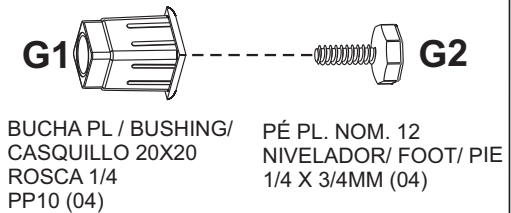
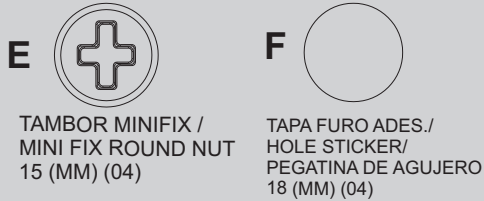
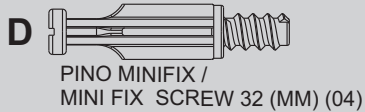
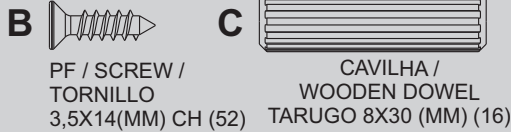
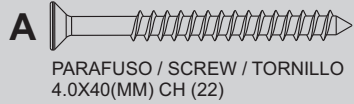

| ITEM | | DESCRIÇÃO DA PEÇAS / DESCRIPTION OF PARTS / UNIT MEASURE USED IS MILLIMETERS (MM) | CORES/ COLORS/ COLORES | | | | | | |
|---|-------|---|-------------------------|-----------|-----------------------|-----------|-------|--------|--|
| COD. CODE | Nº | NOME/ NAME/ NOMBRE | MEDIDAS / MEASURES (MM) | TIPO TYPE | QUANT AMOUNT CANTIDAD | OFF WHITE | PRETO | PINUS | |
| 17254 | 1 | TAMPO/ TOP | 850X468X15 | MDP | 1 | 01/06 | 01/07 | 01/11 | |
| 17255 | 2 | REFORÇO TRÁS/ BACK REINFORCEMENT/ REFUERZO TRASEIRO | 850X100X15 | MDP | 3 | 02/06 | 02/07 | 02/11 | |
| 17256 | 3 | LATERAL ESQUERDA/ LEFT SIDE/ LADO IZQUIERDO | 330X467X15 | MDP | 1 | 03/06 | 03/07 | 03/11 | |
| 17257 | 4 | LATERAL DIREITA/ RIGHT SIDE/ LADO DERECHO | 330X467X15 | MDP | 1 | 04/06 | 04/07 | 04/11 | |
| 17258 | 5 | BASE | 850X468X15 | MDP | 1 | 05/06 | 05/07 | 05/11 | |
| 17259 | 6 | FUNDO TRÁS / BACK/ FONDO TRASERO | 839X360X3 | MDP | 1 | 06/06 | 06/07 | 06/11 | |
| 17260 | 7 | PRATELEIRA CENT./INF/ SHELF/ ESTANTE | 850X468X15 | MDP | 2 | 07/06 | 07/07 | 07/11 | |
| 17261 | 8 | PRATELEIRA SUPERIOR/ HIGHER SHELF/ ESTANTE SUPERIOR | 850X468X15 | MDP | 1 | 08/06 | 08/07 | 08/11 | |
| 17262 | 9 | LAT. GAV ESQ/ LEFT DRAWER SIDE/ LADO CÁJON IZQUIERDO | 400X142X15 | MDP | 2 | 09/06 | 09/07 | 09/11 | |
| 17263 | 10 | LAT. GAV DIR/ RIGHT DRAWER SIDE/ LADO CÁJON DERECHO | 400X142X15 | MDP | 2 | 10/06 | 10/07 | 10/11 | |
| 17264 | 11 | REFORÇO GAV./ REINFORCEMENT DRAWER/ REFUERZO CÁJON | 764X80X15 | MDP | 2 | 11/06 | 11/07 | 11/11 | |
| 17265 | 12 | FRENTE GAVETA/ DRAWER FRONT / FRENTE DE CÁJON | 815X160X15 | MDF | 2 | 12/06 | 12/07 | 12/11 | |
| 17266 | 13 | FUNDO GAV. / DRAWER BACKGROUND/ FONDO CÁJON | 780X408X3 | MDP | 2 | 13/06 | 13/07 | 13/11 | |
| 17267 | 14 | CONT. FRENT. GAV./AGAINST DRAWER FRONT/ CONTRA FRENTE DEL CAJÓN | 764X123X15 | MDP | 2 | 14/06 | 14/07 | 14/11 | |
| 438 | A | PF. / Screw / Tornillo 4,0x40 (MM) CH | | | 22 | | | | |
| 986 | B | PF./ Screw/ Tornillo 3,5x14 (MM) CRR | | | 52 | | | | |
| 137 | C | Cavilha / Wooden Dowel / Tarugo 8x30 (MM) | | | 16 | | | | |
| 532 | D | Pino Minifix / Minifix Screw 32 (MM) | | | 04 | | | | |
| 508 | E | Tambor Minifix / Minifix Round Nut 15 (MM) | | | 04 | | | | |
| 13877 | | | | | | GELO | | | |
| 13363 | F | Tapa F. Ades./Holer Sticker/Pegatina de Agujero 18 mm | | | 04 | | PRETO | | |
| 13876 | | | | | | | | NAT. W | |
| 17450 | G1 | Bucha PL/ Bushing/ Casquillo 20X20 ROSCA 1/4 PP10 | | | 04 | PRETO | PRETO | PRETO | |
| 17449 | G2 | PÉ PL. NOM. 12 NIVELADOR/ FOOT/ PIE 1/4 X 3/4 MM | | | 04 | PRETO | PRETO | PRETO | |
| 140 | H | Corrediça./Metallic Slid/ Corredera 400 (MM) (02 Pair) | | | 02 (PAR) | | | | |
| 248 | I | Prego / Nail / Clavo 8x8 (MM) | | | 25 | | | | |
| 17362 | J | COLUNA METALÃO/METAL COLUMN/COLUMNA METÁLICA-1990X468X20 MM | | | 02 | OURO | OURO | PRETO | |
| 17363 | K | SUPORTE METALP/ CABIDE/ METAL HANGER SUPORT/ SOPORTE METÁLICO-854X70X20 MM | | | 01 | OURO | OURO | PRETO | |
| 17639 | L | PF. / Screw / Tornillo 4,0x40 (MM) FL | | | 32 | | | PRETO | |
| 439 | | | | | | OURO | OURO | | |
| 10006 | Q1/Q2 | Cantoneira PL/Plast. corner with lid / Esquina PL. 20X20X42 (MM) | | | 04 | | | BRANCA | |
| 15175 | | | | | | CINZA | CINZA | | |
| Dispositivo Anti Tombamento PL/ Anti Tipping Kit/ Kit Para no cair | | | | | | | | | |
| 434 | M | Parafuso/ Screw/ Tornillo 4,0x25 CH | | | 04 | | | | |
| 437 | N | Parafuso/ Screw/ Tornillo 4,0x35 CH | | | 04 | | | | |
| 16537 | O | Bucha PL/ Bushing/ Casquillo 6x30 MM Sx6 | | | 04 | | | | |
| 16438 | P1 | Abraçadeira Nylon/ Nylon Clamp/ Abraçadeira Nylon300 (MM) | | | 02 | | | | |
| | P2 | Suport Pl./ Plástico Suport/ Suporte Plástico 47X21X9 (MM) | | | 02 | | | | |
| | | Certif. de Garant./ Warranty Certif. | | | 01 | | | | |

Kit Anti Tombamento/ Anti Tipping Kit/ Kit para no Caer

M PF / SCREW / TORNILLO 4.0x25 (MM) CRR (04)

O BUCHA PL / BUSHING/ CASQUILLO 6X30 MM SX6 (04)

N PF / SCREW / TORNILLO 4.0X35 (MM) CH (04)

P1 ABRAÇADEIRA NYLON/ NYLON CLAMP/ ABRAZADERA NYLON 300MM (02)

P2 SUPORTE PL/ PL SUPPORT 47X21X9 MM (04)

PREPARAÇÃO DE PEÇAS/ PARTS PREPARATION / PREPARACION DE PIEZAS

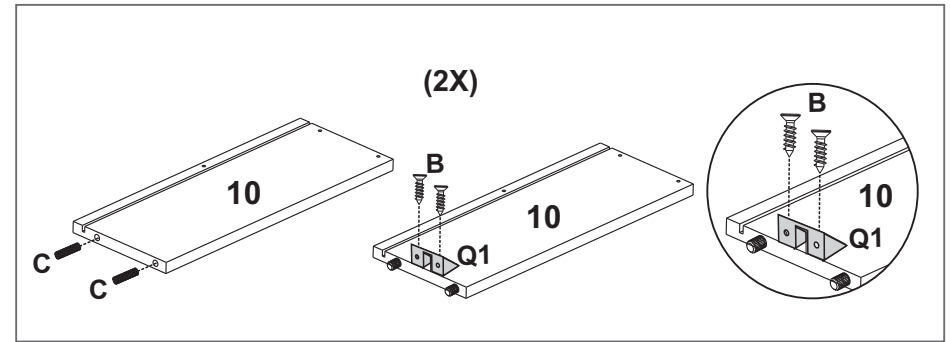
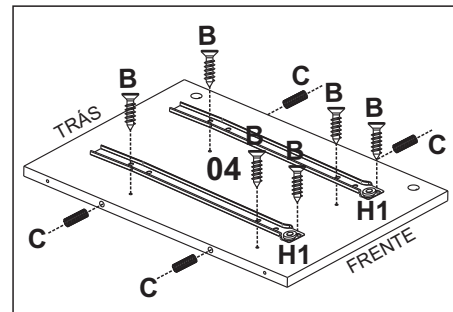
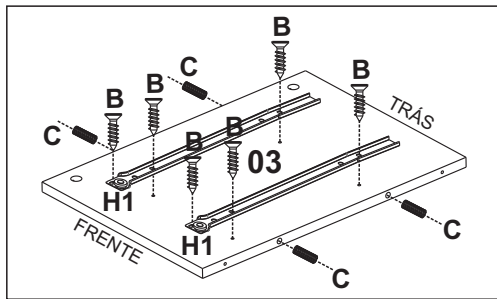
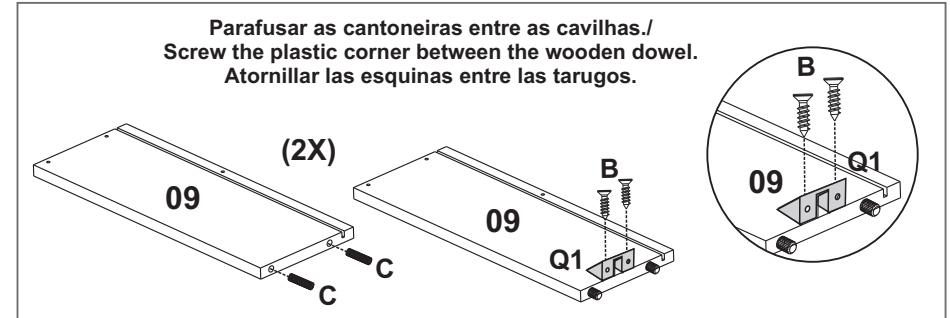
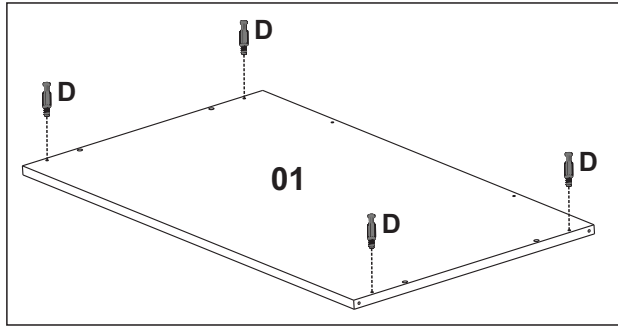
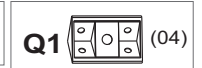
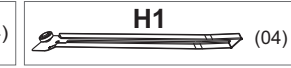
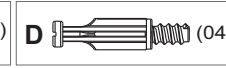

1

Obs: As peças pintadas nos passos são apenas ilustrativas.
The parts painted in the steps are illustrative only.
Las partes pintadas en los pasos son solo ilustrativas.

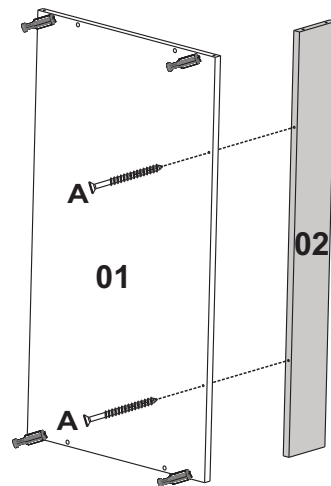
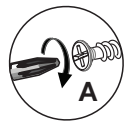

A=02

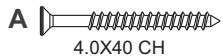

2



E=04
F=04

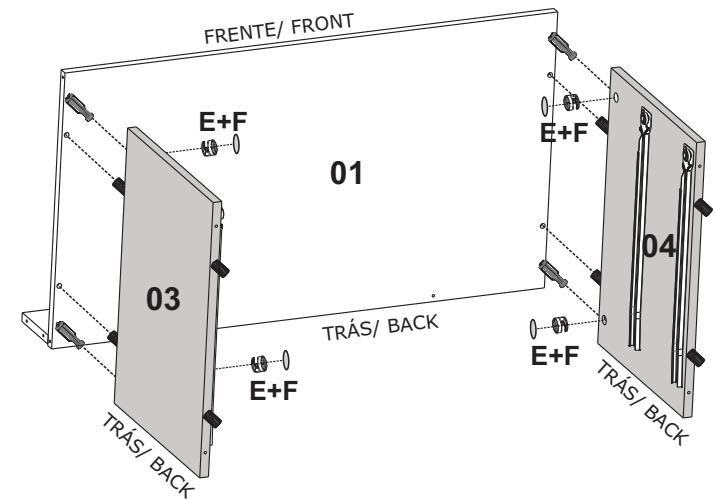

PREPARAÇÃO DE PEÇAS/ PARTS PREPARATION / PREPARACION DE PIEZAS

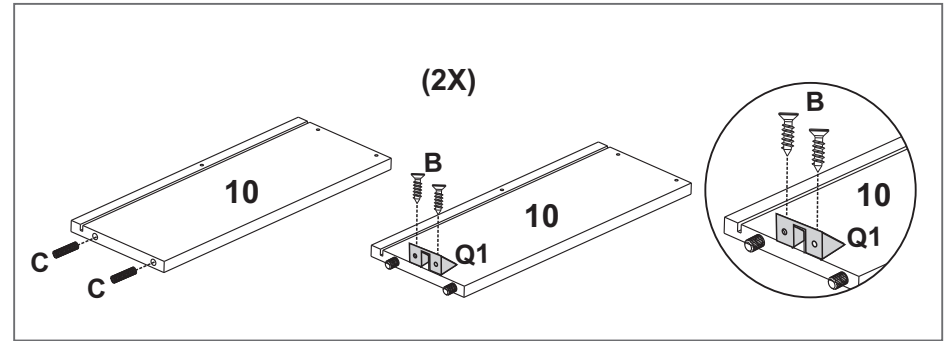
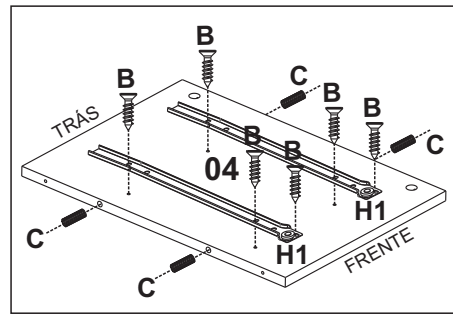
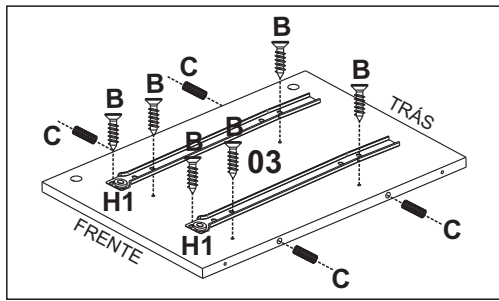
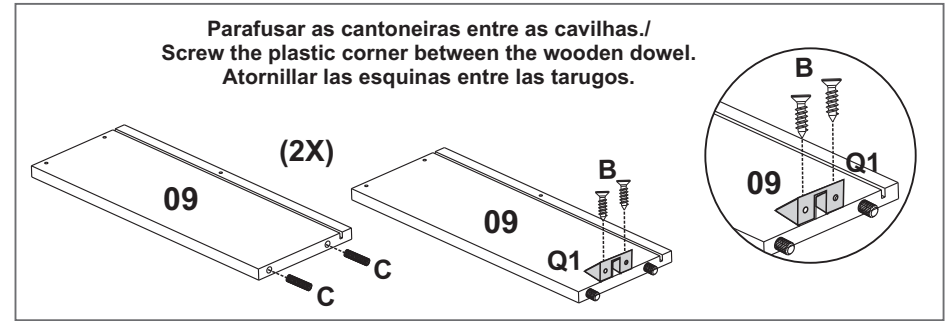
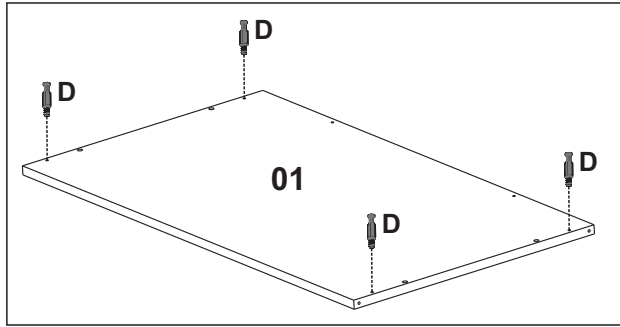
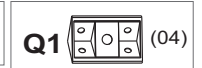
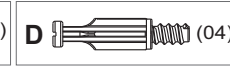

1

Obs: As peças pintadas nos passos são apenas ilustrativas.
The parts painted in the steps are illustrative only.
Las partes pintadas en los pasos son solo ilustrativas.

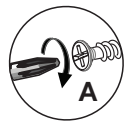

A=02

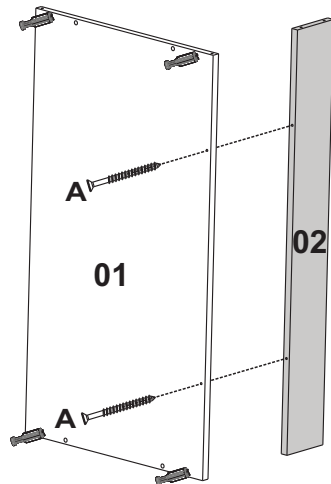
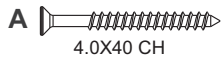

2



E=04
F=04

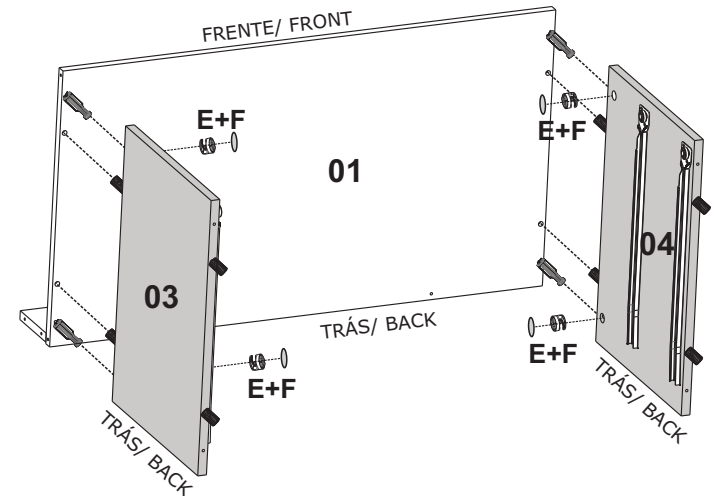

8

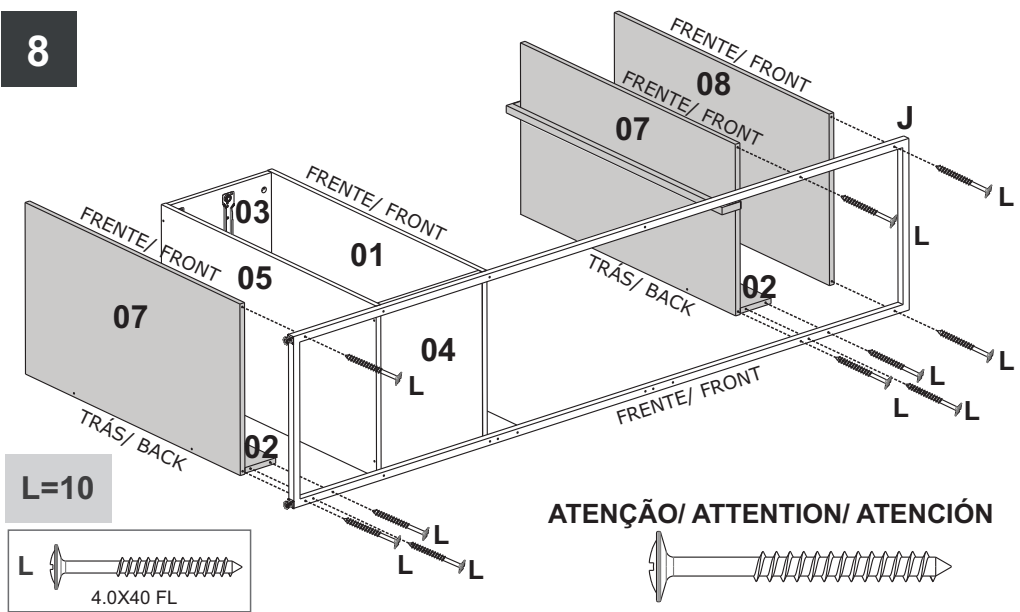

9

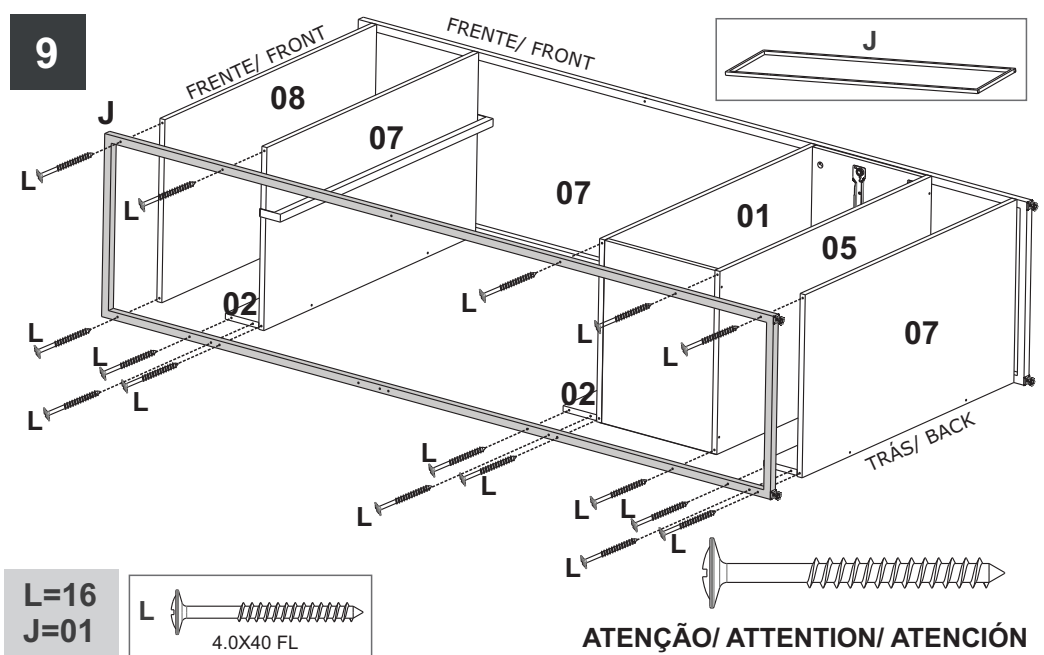

10

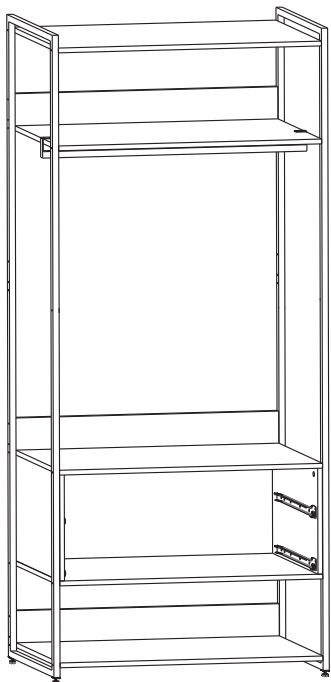

11

REGULAR O PÉ/
FOOT ADJUSTMENT/
AJUSTE PIE

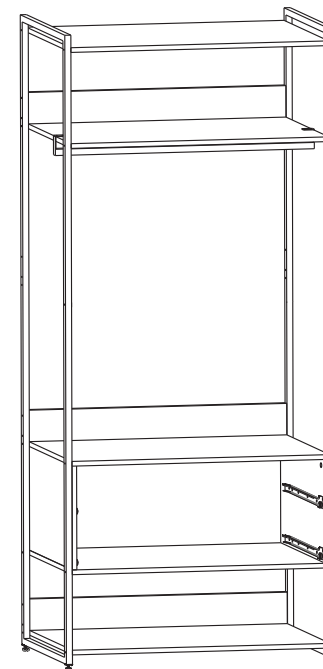
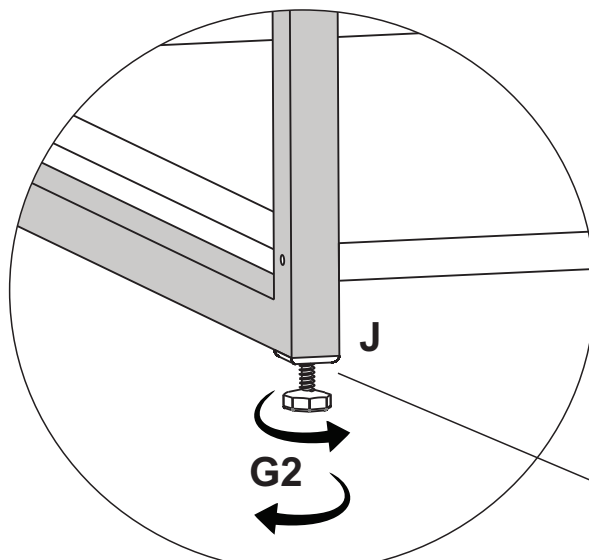

12

MONTAGEM GAVETA / ASSEMBLY OF THE DRAWER / MONTAJE LE CÁJON

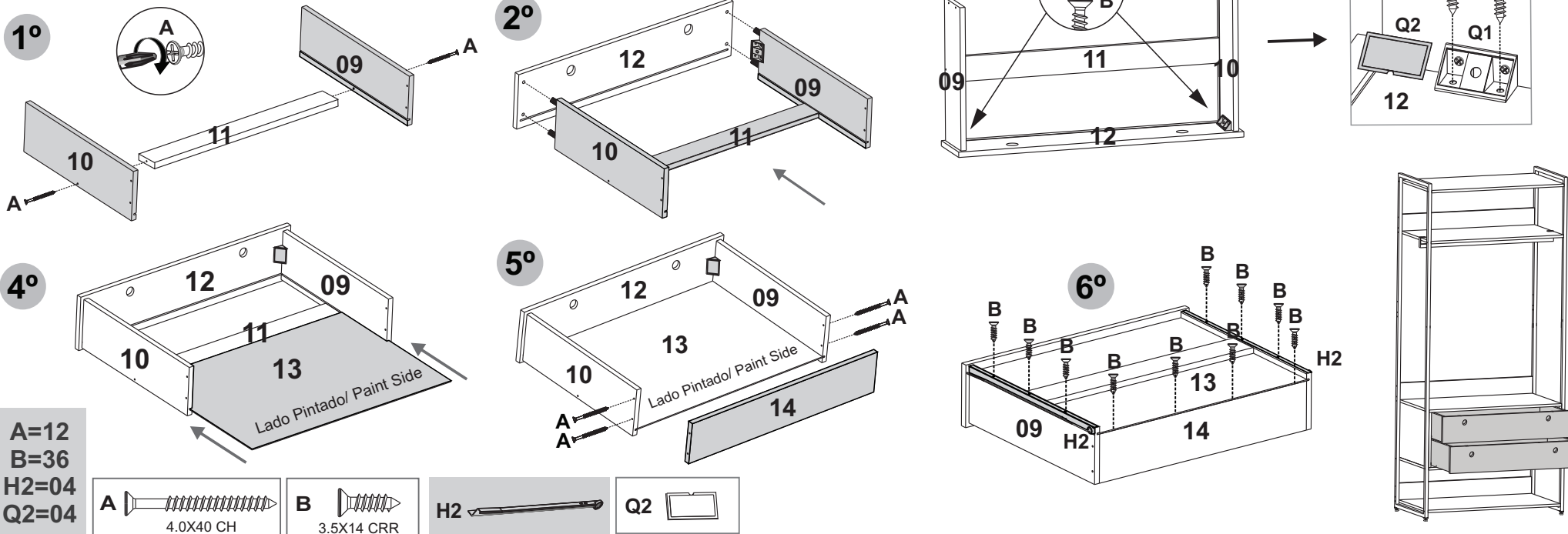

! CUIDADO/ CAUTION/ PRECAUCIÓN

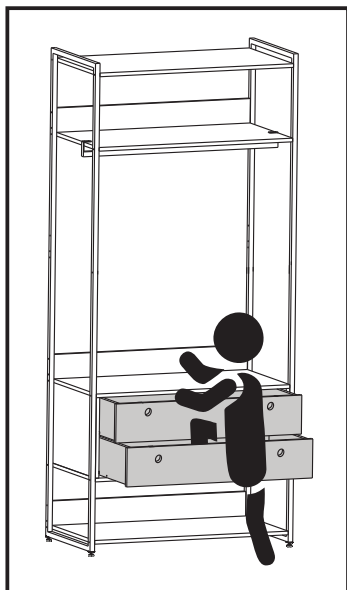

! SE TIVER CRIANÇA, ACONSELHAMOS COLOCAR O KIT TOMBAMENTO, EVITANDO ACIDENTES. IF YOU HAVE A CHILD, WE RECOMMEND PUTTING THE TIPPING KIT, AVOIDING ACCIDENTS. SI TIENE UN HIJO, ACONSEJAMOS PONER EL KIT TIPPING, EVITANDO ACCIDENTES.

Kit Anti Tombamento/ Anti Tipping Kit/ Kit para no Caer

M PF / SCREW / TORNILLO 4,0x25 (MM) CRR (04)

N PF / SCREW / TORNILLO 4,0x35 (MM) CRR (04)

O BUCHA PL / BUSHING/ CASQUILLO 6X30 MM SX6 (04)

P1 ABRACADEIRA NYLON/ NYLON CLAMP/ ABRAZADERA NYLON 300MM (02)

P2 SUPORTE PL/ PL SUPPORT 47X21X9 MM (04)

ATENÇÃO/ ATTENTION / ATENCION

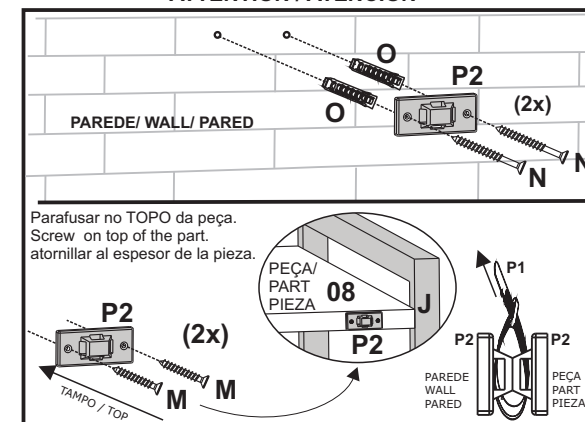

NOTA / NOTE

Não nos responsabilizamos por acidentes, se a instalação do móvel não estiver com os procedimentos deste Manual e não for realizado por pessoa habilitada. We are not responsible for accidents if the installation of the furniture is not in accordance with the procedures in this Manual and is not carried out by a qualified person. No nos hacemos responsables de accidentes si la instalación de los muebles no se realiza de acuerdo con los procedimientos de este Manual y no es realizada por una persona calificada.